

## Solution Brief

# Combining CoolSiC™, CoolMOS™ and EiceDRIVER™

## For energy-smart SMPS designs in industrial applications

Telecom, datacenter and industrial SMPS are driven by the trends of improved energy efficiency, high power density and ever growing output power. Wide-bandgap materials, such as the CoolSiC™ MOSFET 650 V and the CoolGaN™ 600 V e-mode HEMT are enablers to move towards high performance topologies such as CCM totem-pole PFC. A topology that ensures 99% efficiency in the PFC stage, leading to 98% overall system efficiency, while hard commutation is present in every switching cycle. While CoolGaN™ excels in delivering the best efficiency at the highest operating frequency, the CoolSiC™ MOSFET provides the right balance of high efficiency, reliability and ease of use.

### Cost-competitiveness in CCM totem-pole PFC

The CoolSiC™ MOSFET 650 V comes along with roughly 80% lower  $Q_{rr}$  and  $Q_{oss}$  compared to the best silicon alternatives. This ensures outstanding hard-commutation robustness. Due to the low temperature dependency of on-state resistance ( $R_{DS(on)}$ ), the 99% efficiency level can be reached by using a SiC MOSFET with a typical  $R_{DS(on)}$  of 72 mΩ, resulting in system cost reduction. The second half-bridge in the CCM totem-pole PFC runs at low frequencies for half-cycle management. In this case the perfect choice is the 600 V CoolMOS™ S7, a SJ MOSFET, designed for low-frequency switching, offering the lowest  $R_{DS(on)}$  at the best price.

### Highest reliability at improved performance in LLC

A full SMPS design requires a DC-DC stage. LLCs are commonly used soft-switching topologies in which non-continuous hard commutation can occur under certain conditions. Fast-body diode CoolMOS™ series are offering a cost/performance solution but due to the outstanding  $Q_{rr}$  and  $Q_{oss}$  level of the CoolSiC™ MOSFET designs can be even more reliable and at the same time further improve the efficiency level.

### EiceDRIVER™ optimized for CoolSiC™ MOSFET 650 V

1-channel and 2-channel galvanically isolated EiceDRIVER™ gate-driver ICs are the best choices for optimal CoolSiC™ MOSFET 650 V operation. For use in CCM totem-pole PFC functional isolation provides the required robustness against switching noise. In secondary-side controlled LLC stages reinforced isolation is indispensable. 13V UVLO\_off threshold guarantees safe CoolSiC™ operation at current levels required by the applications. The industry-leading low output-stage impedance minimizes CoolSiC™ switching losses. The excellent  $\pm 7$  ns propagation delay accuracy minimizes dead-time losses.

600 V CoolMOS™ S7 is best driven with the EiceDRIVER™ 2EDF7275F.

[www.infineon.com/coolbic-mosfet-discretes](http://www.infineon.com/coolbic-mosfet-discretes)

[www.infineon.com/coolmos](http://www.infineon.com/coolmos)

[www.infineon.com/eicedriver](http://www.infineon.com/eicedriver)

### System features

#### CoolSiC™ 650 V

- > Optimized switching behavior at higher currents
- > Excellent thermal behavior
- > Increased avalanche capability
- > 80% lower  $Q_{rr}$  and  $Q_{oss}$  over SJ MOSFET offerings

#### 600 V CoolMOS™ S7

- > Best-in-class  $R_{DS(on)}$  in SMD packages
- > Optimized for conduction performance in low-frequency-switching topologies

#### EiceDRIVER™

- > 13 V UVLO\_off threshold for safe-operation area
- > 0.35 / 0.85 Ω output stage impedance
- >  $\pm 7$  ns propagation delay precision

### System benefits

- > High performance, high reliability and ease of use
- > Allows high system efficiency
- > Reduces system cost and complexity
- > Enables smaller system size
- > Works in topologies with continuous hard commutation
- > Fit for high temperature and harsh operations
- > Enables bidirectional topologies



# Every switch needs a driver

Combining the latest CoolSiC™ 650 V, the 600 V CoolMOS™ S7 and the 1EDN and 2EDN EiceDRIVER™ families enables engineers to easily design systems which are more efficient, compact, reliable and cost effective. The block diagram gives an idea of such a system:

## High efficiency CoolSiC™ totem pole PFC in server switched mode power supply (SMPS)

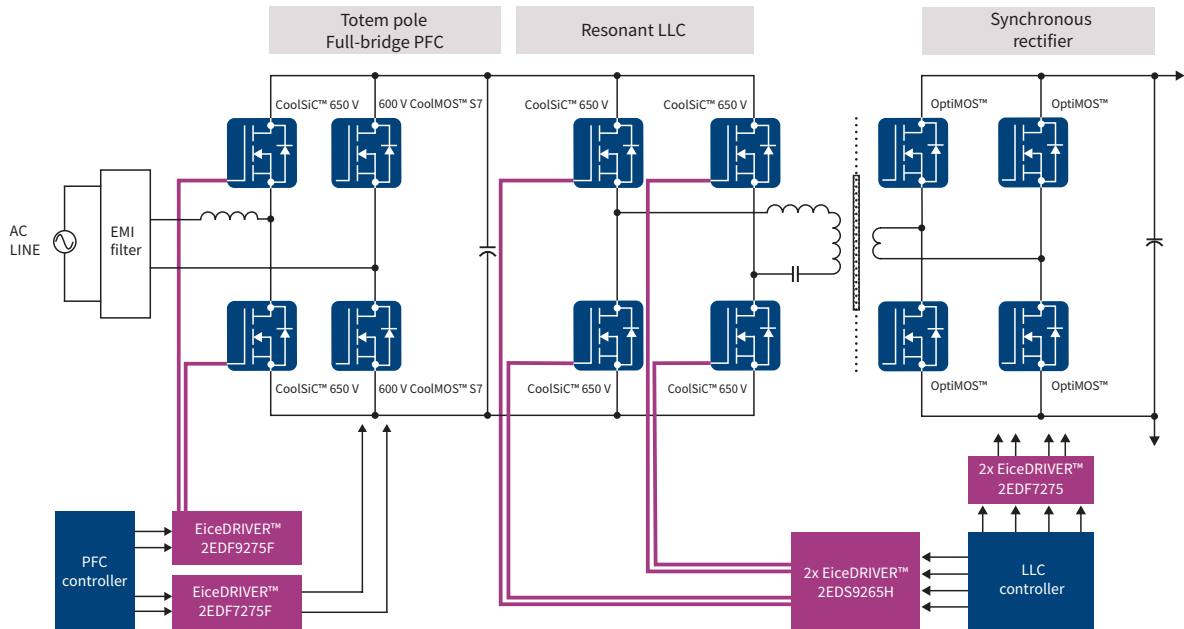

## Portfolio selection

CoolSiC™ MOSFETs 650 V		EiceDRIVER™ for CoolSiC™ MOSFET 650 V		CoolMOS™ S7			EiceDRIVER™ for CoolMOS™ S7		
Package	TO-247-4	TO-247-3	1-channel EiceDRIVER™	2-channel EiceDRIVER™	Package	TO-220	TOLL	2-channel EiceDRIVER™	
$R_{DS(on)}$ typ.					$R_{DS(on)}$ max.				
27 mΩ	IMZA65R027M1H	IMW65R027M1H	1EDB9275F*	2EDF9275F* 2EDS9265H*	10 mΩ	IPDQ60R010S7			
48 mΩ	IMZA65R048M1H	IMW65R048M1H			22 mΩ		IPP60R022S7	IPT60R022S7	2EDF7275F
72 mΩ	IMZA65R072M1H	IMW65R072M1H			40 mΩ			IPT60R040S7	
107 mΩ	IMZA65R107M1H	IMW65R107M1H			65 mΩ			IPT60R065S7	

\* Coming soon

Published by  
Infineon Technologies Austria AG  
9500 Villach, Austria

© 2021 Infineon Technologies AG.  
All Rights Reserved.

### Please note!

This document is for information purposes only and any information given herein shall in no event be regarded as a warranty, guarantee or description of any functionality, conditions and/or quality of our products or any suitability for a particular purpose. With regard to the technical specifications of our products, we kindly ask you to refer to the relevant product data sheets provided by us. Our customers and their technical departments are required to evaluate the suitability of our products for the intended application.

We reserve the right to change this document and/or the information given herein at any time.

### Additional information

For further information on technologies, our products, the application of our products, delivery terms and conditions and/or prices, please contact your nearest Infineon Technologies office ([www.infineon.com](http://www.infineon.com)).

### Warnings

Due to technical requirements, our products may contain dangerous substances. For information on the types in question, please contact your nearest Infineon Technologies office.

Except as otherwise explicitly approved by us in a written document signed by authorized representatives of Infineon Technologies, our products may not be used in any life-endangering applications, including but not limited to medical, nuclear, military, life-critical or any other applications where a failure of the product or any consequences of the use thereof can result in personal injury.

单击下面可查看定价，库存，交付和生命周期等信息

[>>Infineon\(英飞凌\)](#)