

# AN983B/BX

PCI/Mini PCI-to-Ethernet LAN; PQFP - 128Pin

Communications



Never stop thinking.

**Edition 2005-12-15**

**Published by Infineon Technologies AG,  
St.-Martin-Strasse 53,  
81669 München, Germany**

**© Infineon Technologies AG 2005.  
All Rights Reserved.**

**Attention please!**

The information herein is given to describe certain components and shall not be considered as a guarantee of characteristics.

Terms of delivery and rights to technical change reserved.

We hereby disclaim any and all warranties, including but not limited to warranties of non-infringement, regarding circuits, descriptions and charts stated herein.

**Information**

For further information on technology, delivery terms and conditions and prices please contact your nearest Infineon Technologies Office ([www.infineon.com](http://www.infineon.com)).

**Warnings**

Due to technical requirements components may contain dangerous substances. For information on the types in question please contact your nearest Infineon Technologies Office.

Infineon Technologies Components may only be used in life-support devices or systems with the express written approval of Infineon Technologies, if a failure of such components can reasonably be expected to cause the failure of that life-support device or system, or to affect the safety or effectiveness of that device or system. Life support devices or systems are intended to be implanted in the human body, or to support and/or maintain and sustain and/or protect human life. If they fail, it is reasonable to assume that the health of the user or other persons may be endangered.

## AN983B/BX, PCI/Mini PCI-to-Ethernet LAN; PQFP - 128Pin

Revision History: 2005-12-15, Rev. 1.81

### Previous Version:

Page/Date	Subjects (major changes since last revision)
2000-10	Rev.0.1: Draft data sheet for review
2001-02	Rev.1.0: First release
2001-03	Rev.1.1: Add CSR15.bit28 MRXCK, Add CSR18.bit26 PMPEN, Add CSR18.bit27 PMPEN
2001-09	Rev.1.2: Add 25MHz crystal accuracy, Revise PHY registers
2001-09	Rev.1.3: Revise product logo of Pin assignment diagram
Page17,14/ 2001-09	Rev.1.4: 1.MrxD0~D3P.23 CIOSA: 1 means enable; 0 means disable 2.P.14 Add LED info to pin diagram
Page25,40/ 2002-07	Rev.1.5: 1.Offset 80h, DID default value; 0981h 2.CSR18[25]/PWRS_clr; 1 means PCI_reset rising will clear CR49[1:0]/PWRS
Page85/ 2002-07	Rev.1.6: FIG21, FIG22, FIG23, FIG24 added for MII interface signal timing
Page45/ 2002-09	Rev.1.7(B): Unicast registers added, BGA package
Page69/ 2003-05	Rev.1.8(B): Modify some error statement about Loop-back Operation of transceiver
2005-09-13	Rev.1.81: when changed to the new Infineon format
2005-11-30	Minor change. Included Green package information

### Trademarks

ABM®, ACE®, AOP®, ARCOFI®, ASM®, ASP®, DigiTape®, DuSLIC®, EPIC®, ELIC®, FALC®, GEMINAX®, IDEC®, INCA®, IOM®, IPAT®-2, ISAC®, ITAC®, IWE®, IWORX®, MUSAC®, MuSLIC®, OCTAT®, OptiPort®, POTSWIRE®, QUAT®, QuadFALC®, SCOUT®, SICAT®, SICOFI®, SIDEC®, SLICOFI®, SMINT®, SOCRATES®, VINETIC®, 10BaseV®, 10BaseVX® are registered trademarks of Infineon Technologies AG. 10BaseS™, EasyPort™, VDSSLite™ are trademarks of Infineon Technologies AG. Microsoft® is a registered trademark of Microsoft Corporation, Linux® of Linus Torvalds, Visio® of Visio Corporation, and FrameMaker® of Adobe Systems Incorporated.

<b>1</b>	<b>General Description</b>	<b>8</b>
<b>2</b>	<b>System Block Diagram</b>	<b>8</b>
<b>3</b>	<b>Features</b>	<b>8</b>
<b>4</b>	<b>Block Diagram</b>	<b>10</b>
<b>5</b>	<b>Pin Assignment Diagram</b>	<b>11</b>
5.1	Pin Type and Buffer Type Abbreviations	12
<b>6</b>	<b>Pin Description</b>	<b>13</b>
<b>7</b>	<b>Functional Descriptions</b>	<b>19</b>
7.1	Initialization Flow	19
7.2	Network Packet Buffer Management	19
7.2.1	Descriptor Structure Types	19
7.2.2	The Point of Descriptor Management	21
7.3	Transmit Scheme and Transmit Early Interrupt	23
7.3.1	Transmit Flow	23
7.3.2	Transmit Pre-fetch Data Flow	23
7.3.3	Transmit Early interrupt Scheme	24
7.4	Receive Scheme and Receive Early Interrupt Scheme	24
7.5	Network Operation	25
7.5.1	MAC Operation	26
7.5.2	Transceiver Operation	27
7.5.3	Flow Control in Full Duplex Application	29
7.6	LED Display Operation	32
7.6.1	First Mode – 3 LED Displays	32
7.6.2	Second Mode – 4 LED Displays	32
7.7	Reset Operation	32
7.7.1	Reset Whole Chip	32
7.7.2	Reset Transceiver Only	32
7.8	Wake on LAN Function	32
7.8.1	The Magic Packet Format	32
7.8.2	The Wake on LAN Operation	32
7.9	ACPI Power Management Function	33
7.9.1	Power States	33
<b>8</b>	<b>General EEPROM Format Description</b>	<b>35</b>
<b>9</b>	<b>Registers and Descriptors Description</b>	<b>37</b>
9.1	AN983B/BX Configuration Registers	38
9.1.1	AN983B/BX Configuration Registers Descriptions	39
9.2	PCI Control/Status Registers	51
9.2.1	PCI Control/Status Registers Description	52
9.3	PHY Registers(Accessed by CSR9 MDI/MMC/MDO/MDC)	85
9.3.1	PHY Transceiver Registers Descriptions	86
9.4	Descriptors and Buffer Management	94
9.4.1	Receive Descriptor Descriptions	95
9.4.2	Transmit Descriptor Descriptions	99
<b>10</b>	<b>Electrical Specifications and Timings</b>	<b>102</b>
10.1	Absolute Maximum Ratings	102
10.2	DC Specifications	102
10.3	AC Specifications	103
10.4	Timing Specifications	103
<b>11</b>	<b>Package Outlines</b>	<b>111</b>

**Table of Contents**

<b>12</b>	<b>Layout Guide (Rev. 1.0B)</b> .....	<b>113</b>
12.1	Placement .....	113
12.2	Trace Routing .....	113
12.3	$V_{CC}$ and GND .....	114

**List of Figures**

Figure 1	System Diagram of the AN983B/BX	8
Figure 2	Block Diagram of the AN983B/BX	10
Figure 3	Pin Assignment (top view)	11
Figure 4	Initialization Flow	19
Figure 5	Ring Structure of Frame Buffer	20
Figure 6	Chain Structure of Frame Buffer	20
Figure 7	Transmit Pointers for Descriptor Management	21
Figure 8	Receive Pointers for Descriptor Management	22
Figure 9	Transmit Flow	23
Figure 10	Transmit Data Flow of Pre-fetch Data	24
Figure 11	Transmit Normal Interrupt and Early Interrupt Comparison	24
Figure 12	Receive Data Flow (without early interrupt and with early interrupt)	25
Figure 13	Detailed Receive Early Interrupt Flow	25
Figure 14	MAC Control Frame Format	30
Figure 15	PAUSE Operation Receive State Diagram	31
Figure 16	PCI Clock Waveform	104
Figure 17	PCI Timings	105
Figure 18	Flash Write Timings	106
Figure 19	Flash Read Timings	107
Figure 20	Serial EEPROM Timing	108
Figure 21	Transmit Signal Timing Relationships at the MII	109
Figure 22	Receive Signal Timing Relations at the MII	109
Figure 23	MDIO Sourced by STA	110
Figure 24	MDIO Sourced by PHY	110
Figure 25	Package outline for the AN983B / AN983BL	111
Figure 26	Ground Via Trace Arrangement	114
Figure 27	Power Trace Arrangement	114
Figure 28	Ground Plane Arrangement	115

**List of Tables**

Table 1	Abbreviations for Pin Type .....	12
Table 2	Abbreviations for Buffer Type .....	12
Table 3	Pin Definitions and Functions .....	13
Table 4	Format .....	26
Table 5	Power State .....	33
Table 6	Connection Type Definition .....	35
Table 7	Registers Address Space .....	38
Table 8	Registers Overview .....	38
Table 9	Registers Access ConditionsRegisters Access Conditions .....	38
Table 10	Registers Access Types .....	38
Table 11	Registers Clock Domains .....	39
Table 12	Registers Address Space .....	51
Table 13	Registers Overview .....	51
Table 14	Registers Access Types .....	52
Table 15	Registers Address Space .....	85
Table 16	Registers Overview .....	85
Table 17	Registers Access Types .....	85
Table 18	Registers Overview .....	94
Table 19	Registers Access Types .....	94
Table 20	Receive Descriptor Table .....	95
Table 21	Transmit Descriptor Table .....	99
Table 22	Min-Max Ratings .....	102
Table 23	General DC Specifications .....	102
Table 24	PCI Interface DC Specifications .....	102
Table 25	Flash/EEPROM Interface DC Specifications .....	103
Table 26	PCI Signaling AC Specifications for 3.3 V .....	103
Table 27	PCI Clock Specifications .....	103
Table 28	PCI Timings .....	104
Table 29	Flash Interface Timings .....	105
Table 30	EEPROM Interface Timings (AC/AD) .....	107
Table 31	Dimensions for 128 -pin PQFP Package (AN983B/X) .....	111
Table 32	Dimensions for 128 -pin LQFP Package (AN983BLX) .....	112
Table 33	Layout Guide Revision History .....	113

## 1 General Description

The AN983B/BX is a high performance PCI Fast Ethernet controller with a integrated physical layer interface for 10BASE-T and 100BASE-TX applications. The AN983BX is the environmentally friendly “green” package version. The AN983B/BX was designed with advanced CMOS technology to provide a glueless 32-bit bus master interface for PCI, boot ROM interface, and CSMA/CD protocol for Fast Ethernet, as well as the physical media interface for 100BASE-TX of IEEE802.3u and 10BASE-T of IEEE802.3. The auto-negotiation function is also supported for speed and duplex detections.

The AN983B/BX can be programmed as MAC-only controller. In this mode, it provides the standard MII interface to link to an external PHY. With this mode, it can be connected to the HomePNA PHY to support the HomePNA networking solution or Homeplug PHY (Power-line solution) to support Homeplug networking solution.

The AN983B/BX provides both half-duplex and full-duplex operations, as well as supports for full-duplex flow control.

It provides long FIFO buffers for transmission and reception, and an early interrupt mechanism to enhance performance.

The AN983B/BX also supports ACPI and PCI compliant power management functions and Magic Packet wake-up event.

## 2 System Block Diagram

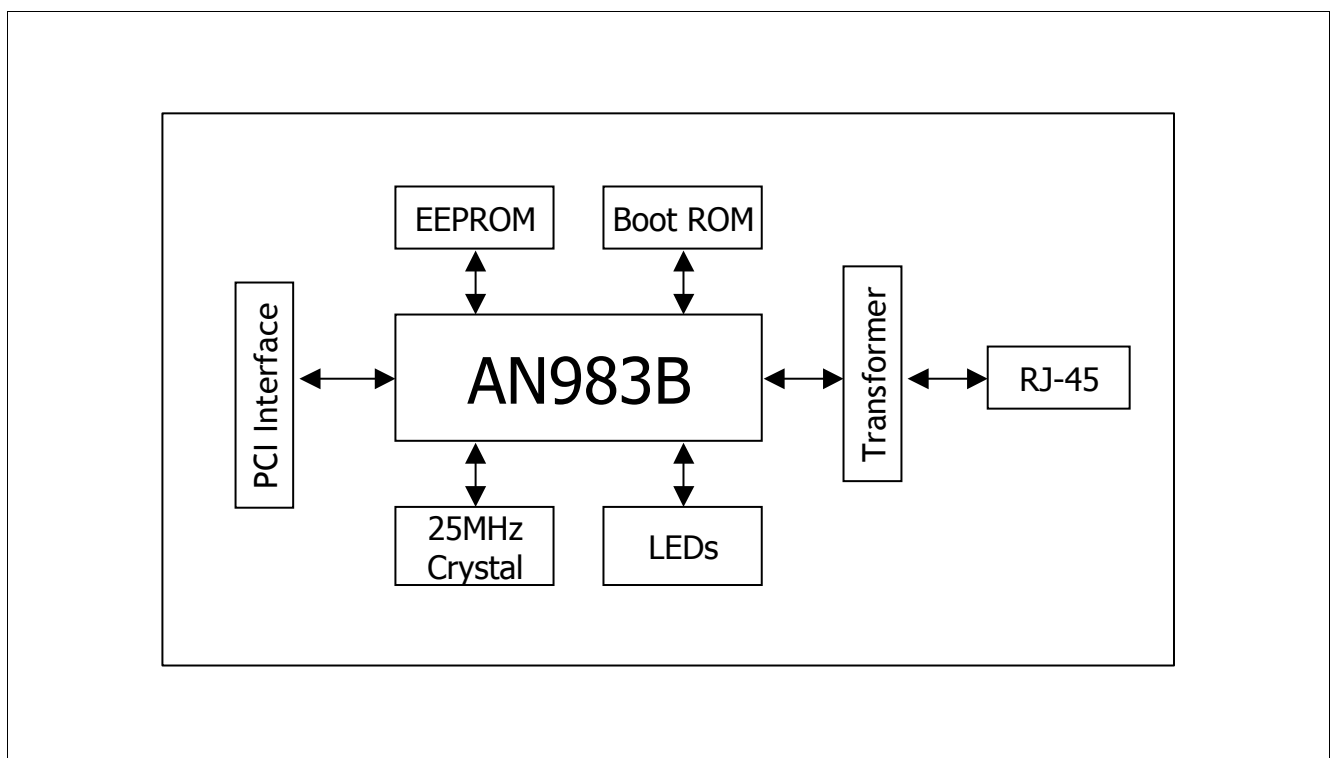

**Figure 1 System Diagram of the AN983B/BX**

## 3 Features

### Industry standard

- IEEE802.3u 100BASE-TX and IEEE802.3 10BASE-T compliant



- Supports for IEEE802.3x flow control
- IEEE802.3u Auto-Negotiation support for 10BASE-T and 100BASE-TX
- PCI Specification 2.2 compliant
- ACPI and PCI power management Ver.1.1 compliant
- Supports PC99 wake on LAN

#### FIFO

- Provides two independent long FIFOs with 2k bytes each for transmission and receiving
- Pre-fetch up to two transmit packets to minimize inter frame gap (IFG) to 0.96  $\mu$ s
- Retransmit collided packet without reload from host memory within 64 bytes
- Automatically retransmit FIFO under-run packet with maximum drain threshold until 3 times retry failure and that will not influence the registers and transmit threshold of next packet

#### PCI I/F

- Provides 32-bit PCI bus master data transfer
- Supports PCI clock with frequency from 0 Hz to 33 MHz
- Supports network operation with PCI system clock from 20 MHz to 33 MHz
- Provides performance meter, PCI bus master latency timer, for tuning the threshold to enhance the performance
- Provides burst transmit packet interrupt and transmit/receive early interrupt to reduce host CPU utilization
- Supports memory-read, memory-read-line, memory-read-multiple, memory-write, memory-write-and-invalidate command while being bus master
- Supports big or little endian byte ordering

#### EEPROM/Boot ROM I/F

- Provides write-able Flash ROM and EPROM as boot ROM with size up to 128 KB
- Provides PCI to access boot ROM by byte, word, or double word
- Re-write Flash boot ROM through I/O port by programming register
- Provides serial interface for read/write 93C46/66 EEPROM
- Automatically load device ID, vendor ID, subsystem ID, subsystem vendor ID, Maximum-Latency, and Minimum-Grand from the 64 byte contents of 93C46/66 after PCI reset de-asserted in PCI environment.

#### MAC/Physical

- Integrates the whole Physical layer functions of 100BASE-TX and 10BASE-T
- Provides Full -duplex operation on both 100 Mbit/s and 10 Mbit/s modes
- Provides Auto-negotiation (NWAY) function of full/half duplex operation for both 10 and 100 Mbit/s
- Provides transmit wave-shaper, receives filters, and adaptive equalizer
- Provides MLT-3 transceiver with DC restoration for Base-line wander compensation
- Provides MAC and Transceiver (TXCVR) loop-back modes for diagnostic
- Built in Stream Cipher Scrambler/ De-scrambler and 4B/5B encoder/decoder
- Supports external transmit transformer with turn ratio 1:1
- Supports external receive transformer with turn ratio 1:1

#### LED Display

- 3 LED displays scheme provided:
  - 100 Mbit/s (on) or Speed 10 (off)
  - Link (keeps on when link ok) or Activity (will be blinking with 10 Hz when receiving or transmitting but not collision)
  - FD (keeps on when in Full duplex mode) or Collision (will be blinking with 20 Hz when colliding)
- 4 LED displays scheme provided:
  - 100 Mbit/s and Link (keep on when link and 100 Mbit/s)
  - 10 Mbit/s and Link (keep on when link and 10 Mbit/s)
  - Activity (will be blinking with 10 Hz when receiving or transmitting but not collision)
  - FD (keeps on when in Full duplex mode) or Collision (will be blinking with 20 Hz when colliding)

**Miscellaneous**

- Provides 128-pin QFP/LQFP packages for PCI/mini-PCI interfaces
- 3.3 V power supply with 5 V/3.3 V I/O tolerance

**4 Block Diagram**

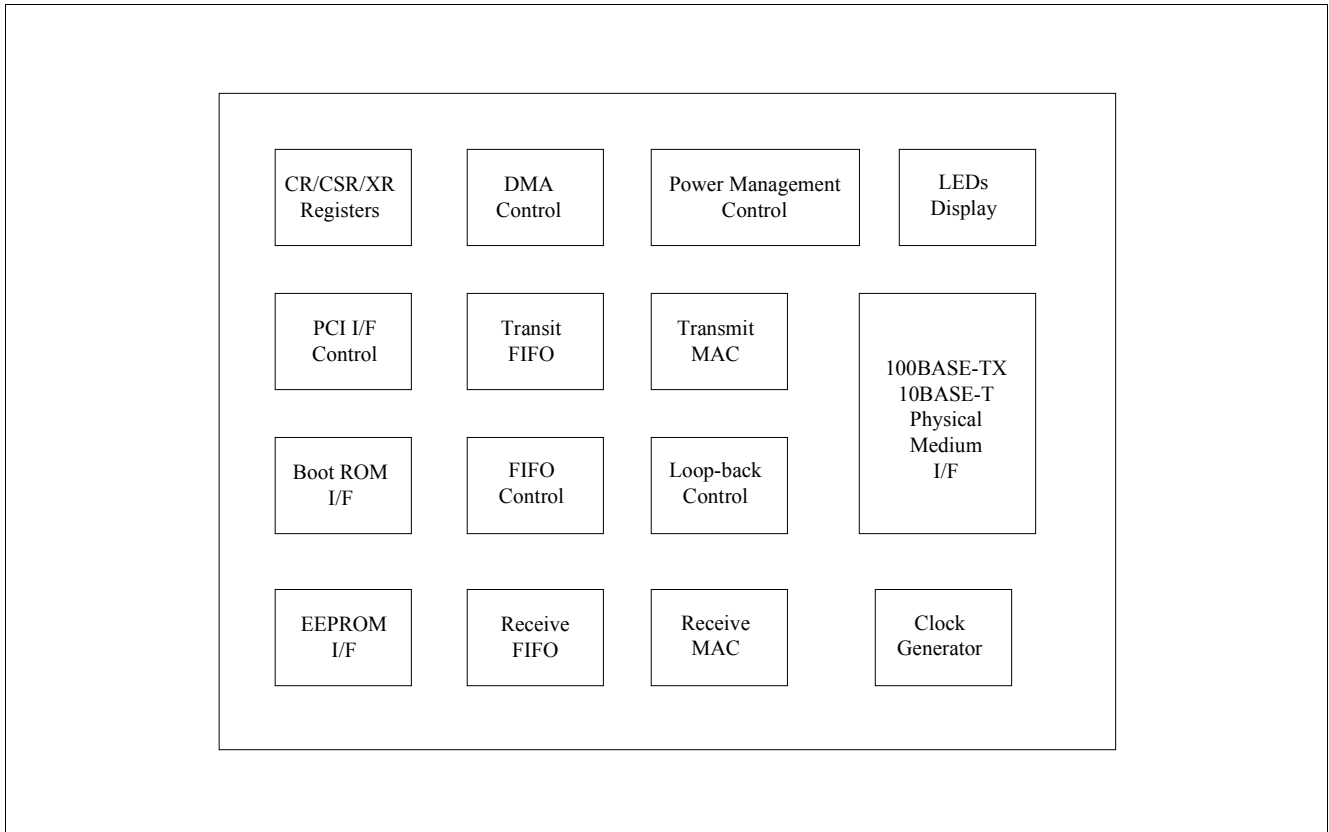

**Figure 2 Block Diagram of the AN983B/BX**

## 5 Pin Assignment Diagram

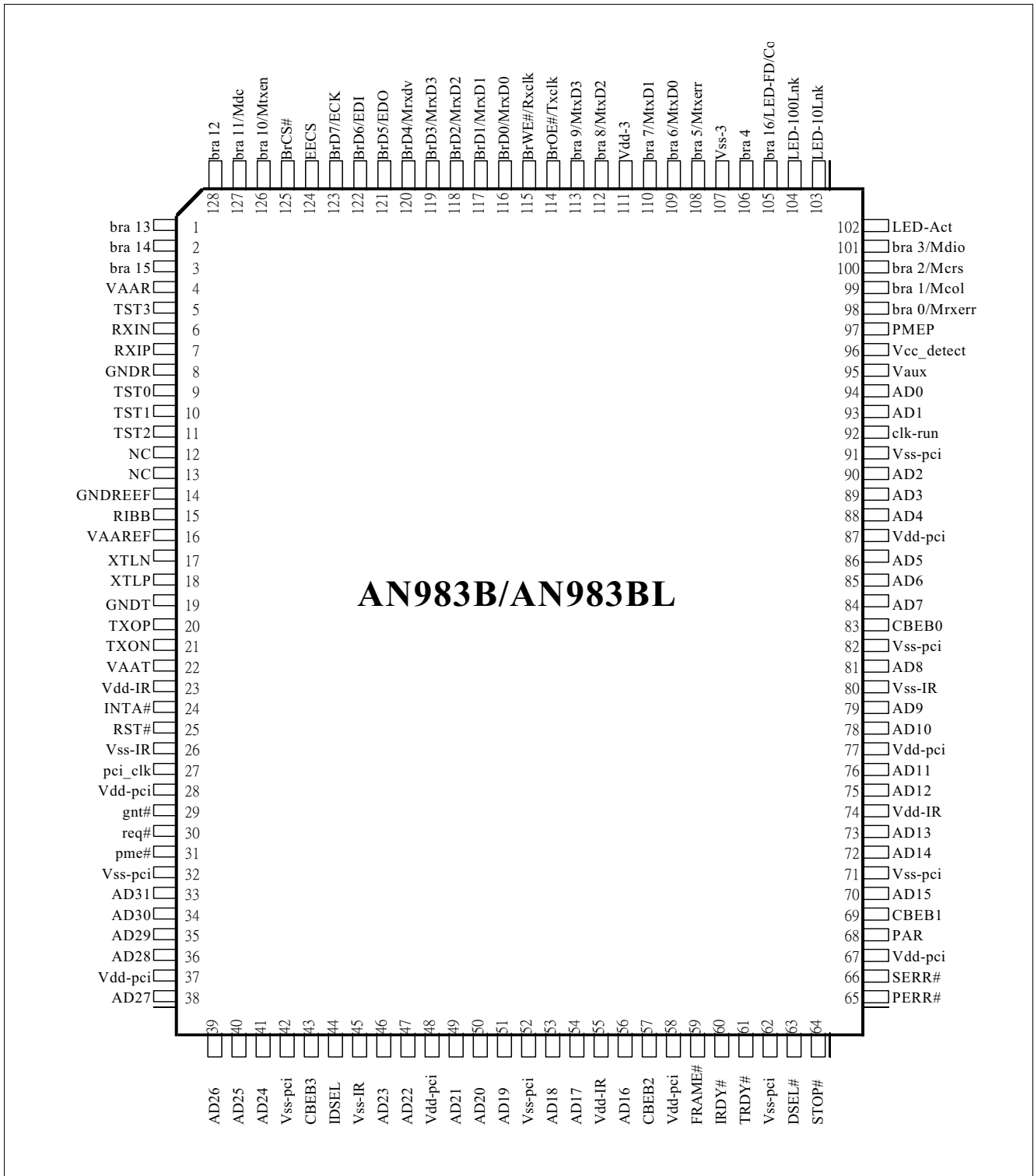

Figure 3 Pin Assignment (top view)

## 5.1 Pin Type and Buffer Type Abbreviations

Standardized abbreviations:

**Table 1 Abbreviations for Pin Type**

Abbreviations	Description
I	Standard input-only pin. Digital levels.
O	Output. Digital levels.
I/O	I/O is a bidirectional input/output signal.
AI	Input. Analog levels.
AO	Output. Analog levels.
AI/O	Input or Output. Analog levels.
PWR	Power
GND	Ground
MCL	Must be connected to Low (JEDEC Standard)
MCH	Must be connected to High (JEDEC Standard)
NU	Not Usable (JEDEC Standard)
NC	Not Connected (JEDEC Standard)

**Table 2 Abbreviations for Buffer Type**

Abbreviations	Description
Z	High impedance
PU1	Pull up, 10 k $\Omega$
PD1	Pull down, 10 k $\Omega$
PD2	Pull down, 20 k $\Omega$
TS	Tristate capability: The corresponding pin has 3 operational states: Low, high and high-impedance.
OD	Open Drain. The corresponding pin has 2 operational states, active low and tristate, and allows multiple devices to share as a wire-OR. An external pull-up is required to sustain the inactive state until another agent drives it, and must be provided by the central resource.
OC	Open Collector
PP	Push-Pull. The corresponding pin has 2 operational states: Active-low and active-high (identical to output with no type attribute).
OD/PP	Open-Drain or Push-Pull. The corresponding pin can be configured either as an output with the OD attribute or as an output with the PP attribute.
ST	Schmitt-Trigger characteristics
TTL	TTL characteristics

## 6 Pin Description

**Table 3 Pin Definitions and Functions**

Pin or Ball No.	Name	Pin Type	Buffer Type	Function
<b>PCI Interface</b>				
24	INTA#	O/D		<b>PCI Interrupt Request</b> AN983B/BX asserts this signal when one of the interrupt events occurs.
25	RST#	I		<b>PCI Signal to Initialize the AN983B/BX</b> The active reset signal should be sustained at least 100 $\mu$ s to guarantee that the AN983B/BX has completed the initializing activity. During the reset period, all the output pins of AN983B/BX will be set to tristate and all the O/D pins are floated.
27	PCI-CLK	I		<b>This PCI Clock Inputs to AN983B/BX for PCI Relative Circuits as the Synchronized Timing Base with PCI Bus</b> The Bus signals are recognized on rising edge of PCI-CLK. In order to let network operating properly, the frequency range of PCI-CLK is limited between 20 MHz and 33 MHz when network operating.
29	GNT#	I		<b>PCI Bus Granted</b> This signal indicates that the PCI bus request of AN983B/BX has been accepted.
30	REQ#	O		<b>PCI Bus Request</b> Bus master device want to get bus access right
31	PME#	I/O		<b>Power Management Event</b> The Power Management Event signal is an open drain, active low signal. When WOL-bit 18 of CSR 18 be set into "1", means that the AN983B/BX is set into Wake On LAN mode. In this mode, when the AN983B/BX receives a Magic Packet frame from network then the AN983B/BX will active this signal too. In the Wake On LAN mode, when LWS-bit (bit 17) of CSR18 is set into "1" means the LAN-WAKE signal is HP-style signal, otherwise it is IBM-style signal.

Table 3 Pin Definitions and Functions (cont'd)

Pin or Ball No.	Name	Pin Type	Buffer Type	Function
33, 34	AD-31, 30	I/O		<b>Multiplexed Address Data Pin of PCI Bus</b>
35, 36	AD-29, 28			
38, 39	AD-27, 26			
40, 41	AD-25, 24			
46, 47	AD-23, 22			
49, 50	AD-21, 20			
51, 53	AD-19, 18			
54, 56	AD-17, 16			
70, 72	AD-15, 14			
73, 75	AD-13, 12			
76, 78	AD-11, 10			
79, 81	AD-9, 8			
84, 85	AD-7, 6			
86, 88	AD-5, 4			
89, 90	AD-3, 2			
93, 94	AD-1, 0			
43	C-BEB3	I/O		<b>Bus Command and Byte Enable</b>
57	C-BEB2			
69	C-BEB1			
83	C-BEB0			
44	IDSEL	I		<b>Initialization Device Select</b> This signal is asserted when host issues the configuration cycles to the AN983B/BX.
59	FRAME#	I/O		<b>Begin and Duration of Bus Access</b> Driven by master device
60	IRDY#	I/O		<b>Master Device is Ready to Data Transaction</b>
61	TRDY#	I/O		<b>Slave Device is Ready to Data Transaction</b>
63	DEVSEL#	I/O		<b>Device Select</b> Device select, target is driving to indicate the address is decoded
64	STOP#	I/O		<b>Stop the Current Transaction</b> Target device request the master device to stop the current transaction
65	PERR#	I/O		<b>Data Parity Error</b> Data parity error is detected, driven by the agent receiving data
66	SERR#	O/D		<b>Address Parity Error</b>
68	PAR	I/O		<b>Parity</b> Parity, even parity (AD [31:0] + C/BE [3:0]), master drives par for address and write data phase, target drives par for read data phase

**Table 3 Pin Definitions and Functions (cont'd)**

Pin or Ball No.	Name	Pin Type	Buffer Type	Function
92	Clk-run	I/O	OD	<b>Clock Run for PCI System</b> In the normal operation situation, Host should assert this signal to indicate AN983B/BX about the normal situation. On the other hand, when Host will deassert this signal when the clock is going down to a non-operating frequency. When AN983B/BX recognizes the deasserted status of clk-run, then it will assert clk-run to request host to maintain the normal clock operation. When clk-run function is disabled then the AN983B/BX will set clk-run in tristate.
<b>BOOTROM/EEPROM Interface</b>				
98	BrA0	I/O		<b>ROM Data Bus</b> Provides up to 128KB EPROM or Flash-ROM application space.
99	BrA1			
100	BrA2			
101	BrA3			
106	BrA4			
108	BrA5			
109	BrA6			
110	BrA7			
112	BrA8			
113	BrA9			
126	BrA10			
127	BrA11			
128	BrA12			
1	BrA13			
2	BrA14			
3	BrA15			
105	BrA16			
116	BrD0	IO		<b>BootROM Data Bus Bit (0~7)</b>  Input/Output data for AN983B/BX EDO: Data Output of serial EEPROM EDI: Data Input of serial EEPROM ECK: Clock input of serial EEPROM The AN983B/BX output clock signal to EEPROM.
117	BrD1			
118	BrD2			
119	BrD3			
120	BrD4			
121	BrD5/EDO	IO/O		
123	BrD6/EDI BrD7/ECK	IO/I IO/I		
124	EECS	O		<b>Chip Select of Serial EEPROM</b>
125	BrCS#	O		<b>BootROM Chip Select</b>
114	BrOE#	O		<b>BootROM Read Enable for Flash ROM Application</b>
115	BrWE#	O		<b>BootROM Write Enable for Flash ROM Application</b>
<b>MII Interface (Program AN983B/BX as MAC-Only Mode, Set FCH [2:0] =100B)</b>				
127	Mdc	O		<b>MII Management Data Clock</b>

Table 3 Pin Definitions and Functions (cont'd)

Pin or Ball No.	Name	Pin Type	Buffer Type	Function
128	Mtxen	O		<b>MII Transmit Enable</b>
109	MtxD0	O		<b>MII Transmit Data</b>
110	MtxD1			
112	MtxD2			
113	MtxD3			
108	Mtxerr	O		<b>MII Transmit Error</b>
101	Mdio	I/O		<b>MII Management Data I/O</b>
120	Mrxdv	I		<b>MII Receive Data Valid</b>
100	Mcrs	I		<b>MII Carrier Sense</b>
116	MrxD0	I		<b>MII Receive Data</b>
117	MrxD1			
118	MrxD2			
119	MrxD3			
99	Mcol	I		<b>MII Collision</b>
98	Mrxerr	I		<b>MII Receive Error</b>
115	Rxclk	I		<b>MII Receive Clock</b>
114	Txclk	I		<b>MII Transmit Clock</b>

**Physical Interface**

18	XTLP	I		<b>Crystal Inputs</b> To be connected to a 25 MHz crystal with 50 ppm accuracy.
17	XTLN			
6	RXIN	I		<b>Differentials Receive Inputs</b> The differentials receive inputs of 100BASE-TX or 10BASE-T, these pins directly input from Magnetic.
7	RXIP			
20	TXOP	O		<b>Differential Transmit Outputs</b> The differential Transmit outputs of 100BASE-TX or 10BASE-T, these pins directly output to Magnetic.
21	TXON			
15	RIBB	I		<b>Reference Bias Resistor</b> To be tied to an external 10.0K (1%) resistor which should be connected to the analog ground at the other end.
9	TST0	I		<b>Test Pin</b>
10	TST1			
11	TST2			
5	TST3			
12, 13	NC	O		

**LED Display and Miscellaneous**



Table 3 Pin Definitions and Functions (cont'd)

Pin or Ball No.	Name	Pin Type	Buffer Type	Function
102	Led-Act	O		<b>4 LED Mode: LED Display for Activity Status</b> This pin will be driven on with 10 Hz blinking frequency when either effective receiving or transmitting is detected.
	(Led-Lnk/act)	O		<b>(3 LED Mode): LED Display for Link and Activity Status</b> This pin will be driven on continually when a good Link test is detected. This pin will be driven on with 10 Hz blinking frequency when either effective receiving or transmitting is detected.
103	Led-10Lnk	O		<b>4 LED Mode: LED Display for 10 Mbit/s Speed</b> This pin will be driven on continually when the 10 Mbit/s network operating speed is detected.
	(Led-fd/col)	O		<b>(3 LED Mode): LED Display for Full Duplex or Collision Status</b> This pin will be driven on continually when a full duplex configuration is detected. This pin will be driven on with 20 Hz blinking frequency when a collision status is detected in the half duplex configuration.
104	Led-100Lnk	O		<b>4 LED Mode: LED Display for 100 Mbit/s Speed</b> This pin will be driven on continually when the 100 Mbit/s network operating speed is detected.
	(Led-speed)	O		<b>(3 LED Mode): LED Display for 100 Mbit/s or 10 Mbit/s speed</b> This pin will be driven on continually when the 100M b/s network operating speed is detected.
105	Led-Fd/Col	O		<b>4 LED Mode: LED Display for Full Duplex or Collision Status</b> This pin will be driven on continually when a full duplex configuration is detected. This pin will be driven on with 20 Hz blinking frequency when a collision status is detected in the half duplex configuration. (3 LED Mode): none
95	Vaux	I		When this pin is asserted, it indicates an auxiliary power source is supported. ACPI purpose, for detecting the auxiliary power source. This pin should be or-wired connected to: 1) 3.3 V when 3.3 Vaux support, or 2) 5 V when 5 Vaux support from 3-way switch.
96	Vcc-detect	I		When this pin is asserted, it indicates PCI power source is supported. ACPI purpose, for detecting the main power is remained or not. This pin should be connected to PCI bus power source +5 V.

**Table 3 Pin Definitions and Functions (cont'd)**

Pin or Ball No.	Name	Pin Type	Buffer Type	Function
97	PMEP	O		This signal is used as the WOL pin. It provides a programmable positive or negative pulse with approximately 50 ms width.
<b>Digital Power Pins</b>				
26, 32, 42, 45, 52, 62, 71, 80, 82, 91, 107	$V_{ss-pci}$ , $V_{ss-IR}$ , $V_{ss-3}$			
23, 28, 37, 48, 55, 58, 67, 74, 77, 87, 111	$V_{dd-pci}$ , $V_{dd-IR}$ , $V_{dd-3}$			<b>Connect to 3.3 V</b>
<b>Analog Power Pins</b>				
4, 16, 22	$V_{AAR}$ , $V_{AAREF}$ , $V_{AAT}$ , 3.3 V			
8, 14, 19	GNDR, GNDREF, GNDT			

## 7 Functional Descriptions

### 7.1 Initialization Flow

The flow of initialize AN983B/BX is shown as below.

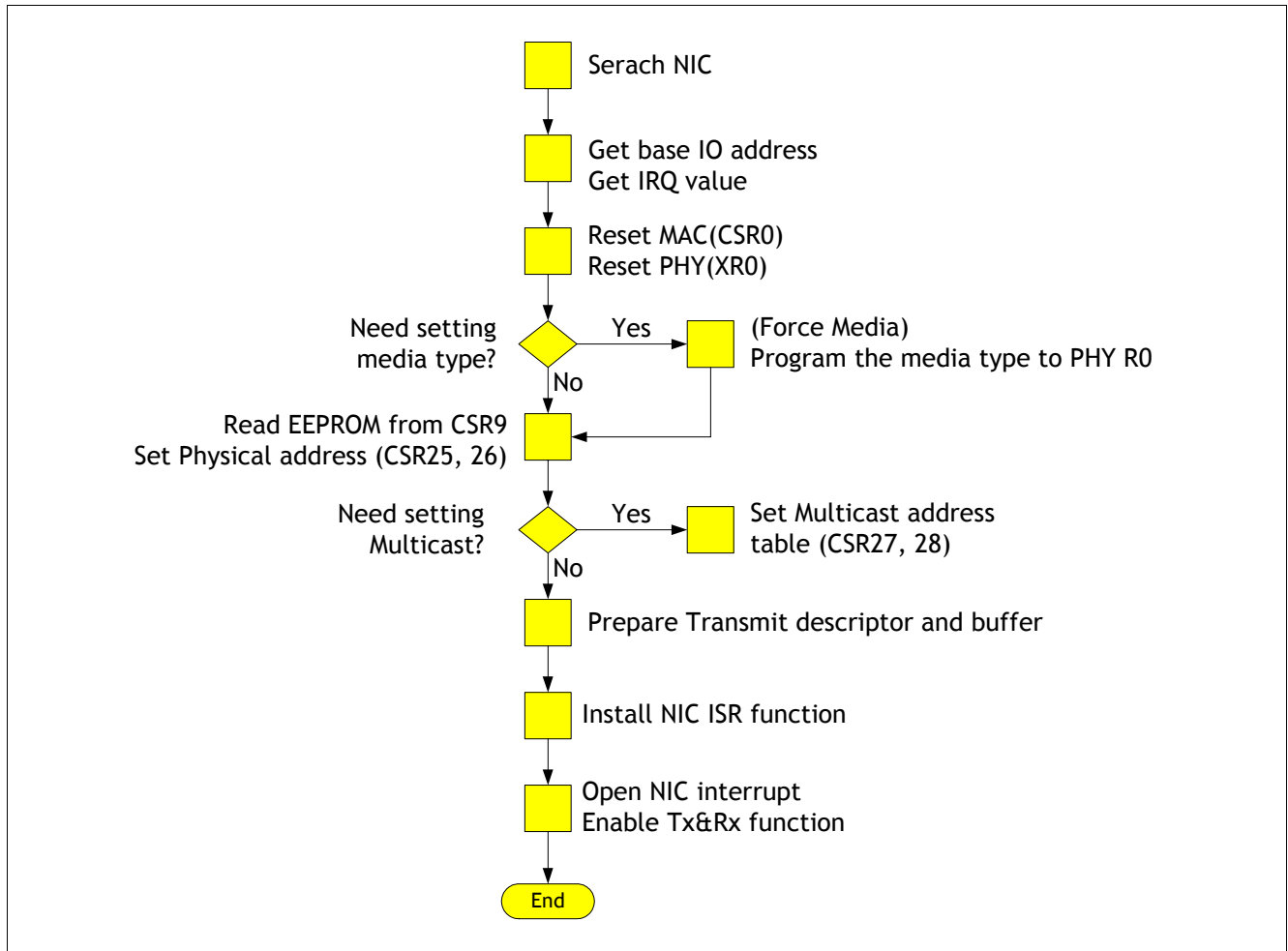

Figure 4 Initialization Flow

### 7.2 Network Packet Buffer Management

#### 7.2.1 Descriptor Structure Types

For networking operations the AN983B/BX transmits the data packet from transmit buffers in host memory to AN983B/BX's transmit FIFO and receives the data packet from AN983B/BX's receiving FIFO to receive buffers in host memory. The descriptors that the AN983B/BX supports to build in host memory are used as the pointers of these transmit and receive buffers.

There are two structure types for the descriptor, **Ring and Chain**, supported by the AN983B/BX and are shown as below. The type selection is controlled by the bit24 of RDES1 and the bit24 of TDES1.

The transmitting and receiving buffers are physically built in host memory. Any buffer can contain either a whole packet or just parts of a packet. But it can't contain more than one packet.

- Ring structure

There are two buffers per descriptor in the ring structure. Support receives early interrupt.

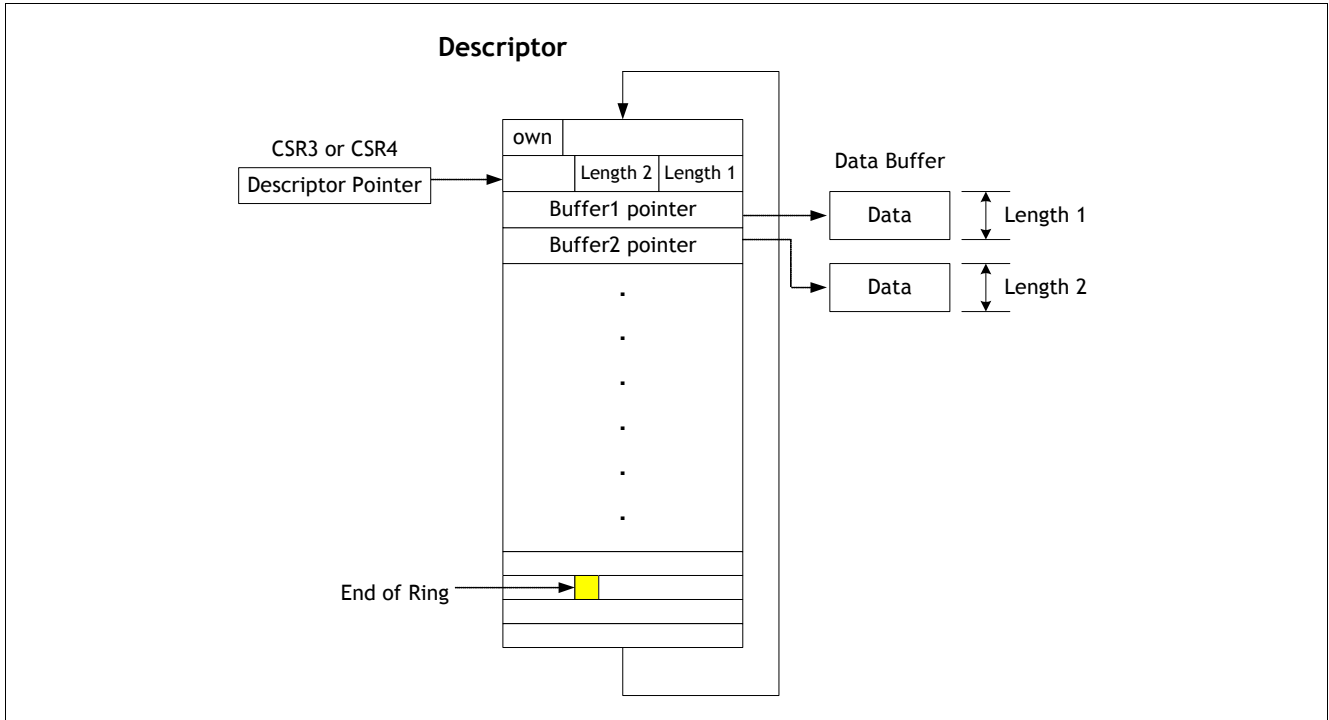

**Figure 5 Ring Structure of Frame Buffer**

- Chain structure

There is only one buffer per descriptor in chain structure.

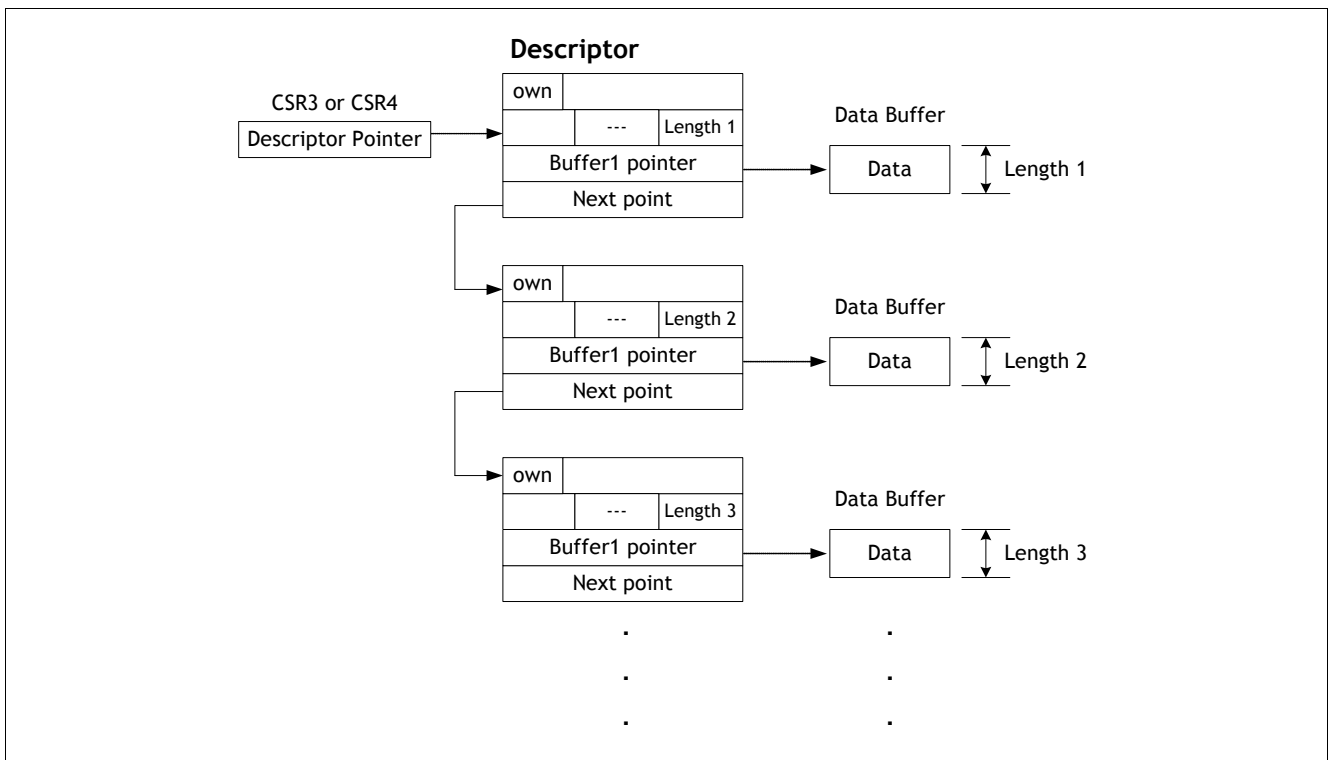

**Figure 6 Chain Structure of Frame Buffer**

### 7.2.2 The Point of Descriptor Management

OWN bit = 1, ready for network side access

OWN bit = 0, ready for host side access

- Transmit Descriptor Pointers

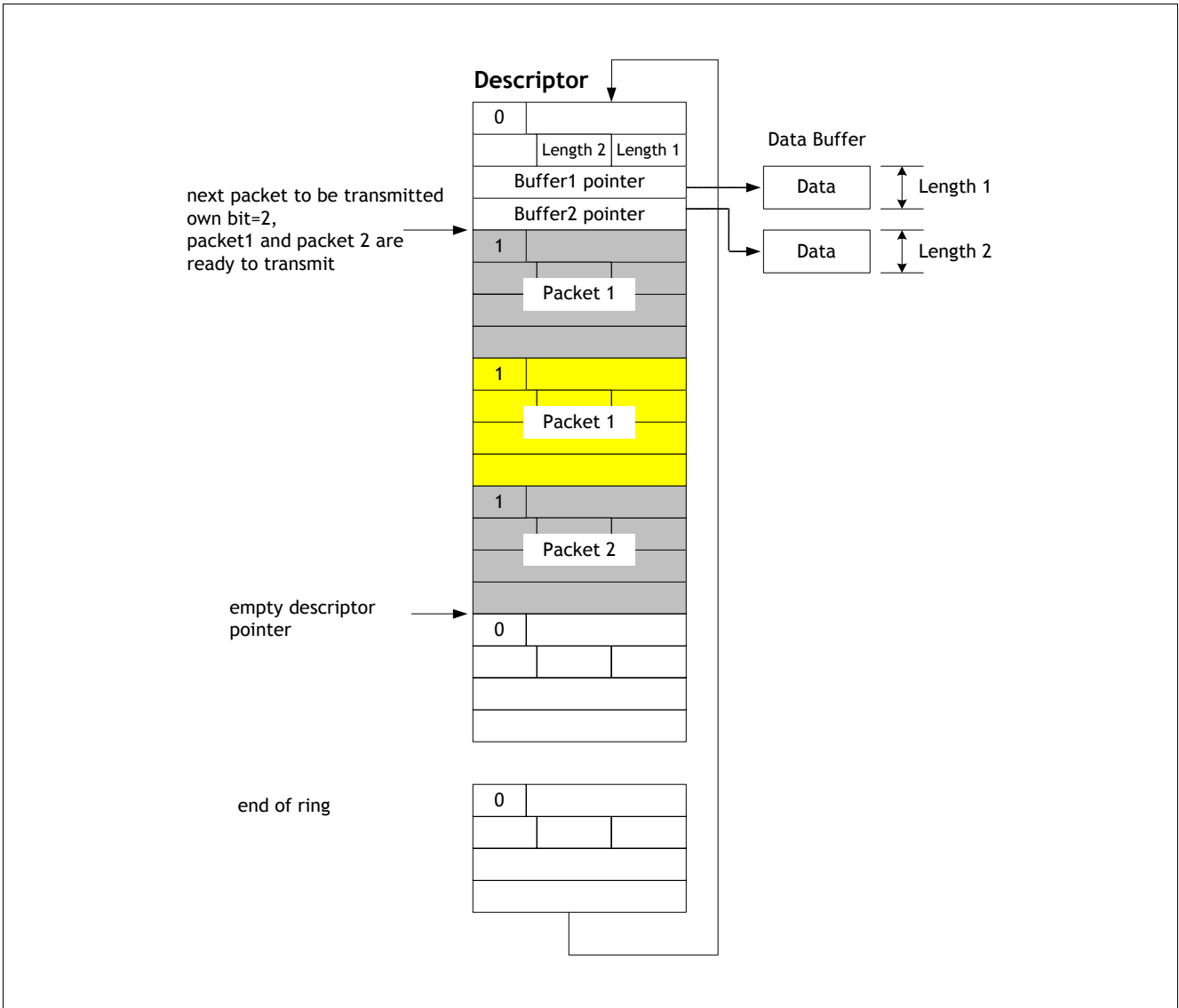

**Figure 7 Transmit Pointers for Descriptor Management**

- Receive Descriptor Pointers

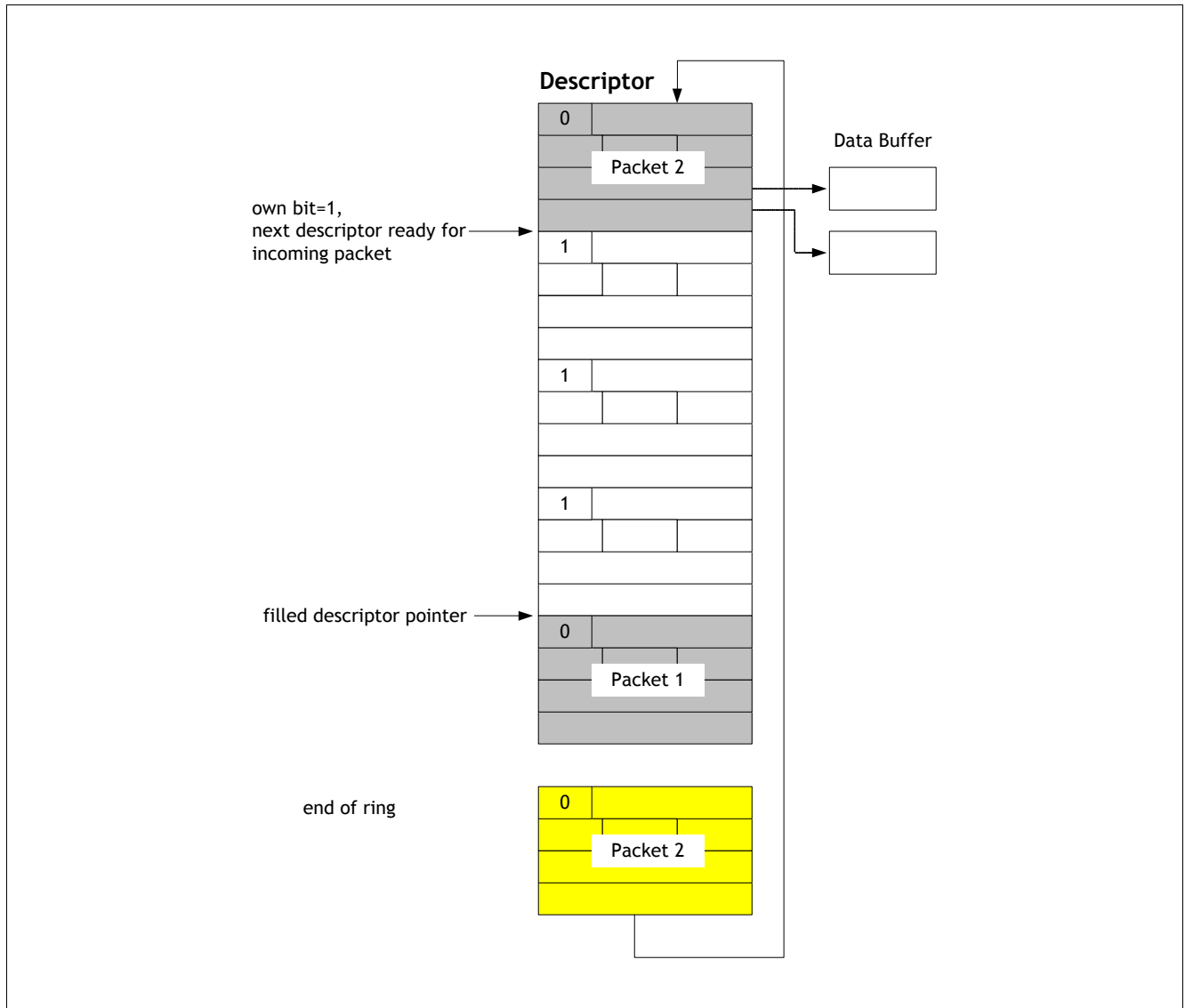

Figure 8 Receive Pointers for Descriptor Management

## 7.3 Transmit Scheme and Transmit Early Interrupt

### 7.3.1 Transmit Flow

The flow of packet transmit is shown as below.

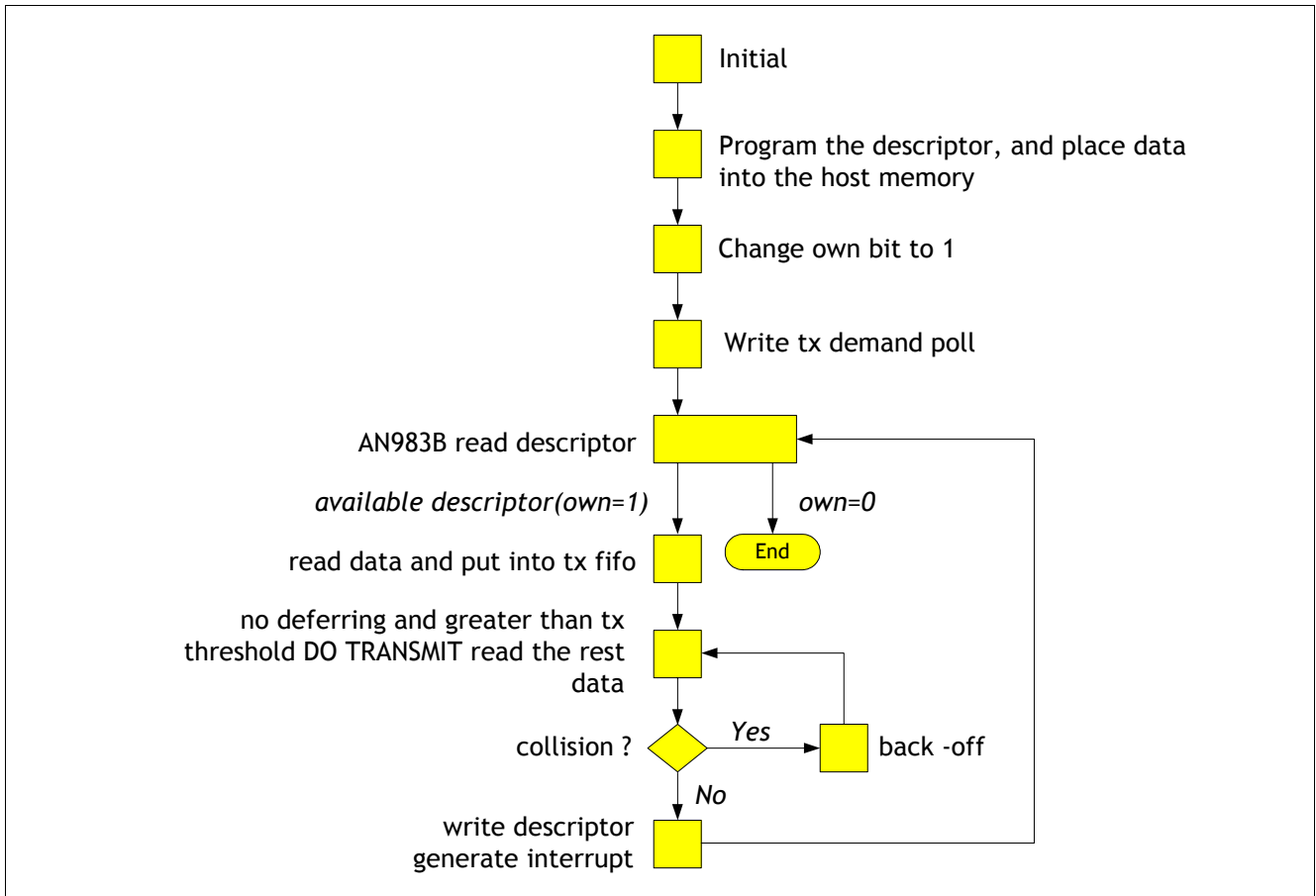

Figure 9 Transmit Flow

### 7.3.2 Transmit Pre-fetch Data Flow

- Transmit FIFO size = 2K-byte
- Two packets in the FIFO at the same time
- Meet the transmit min. back-to-back

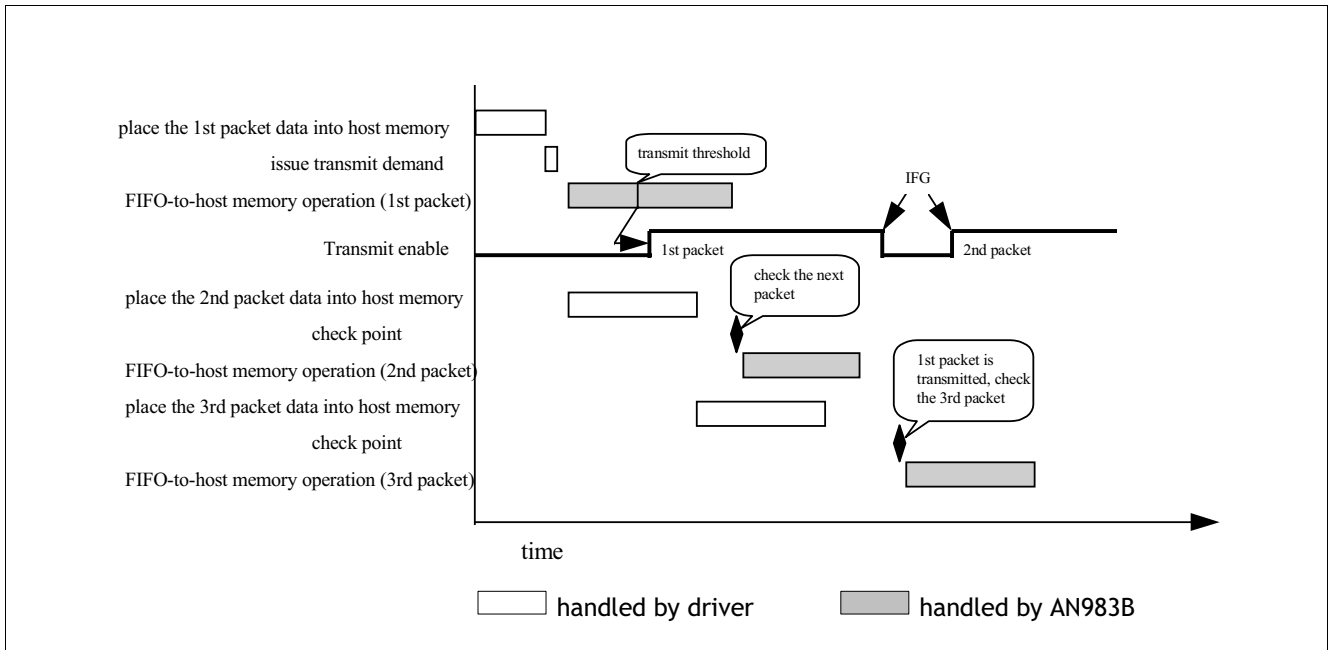

Figure 10 Transmit Data Flow of Pre-fetch Data

### 7.3.3 Transmit Early interrupt Scheme

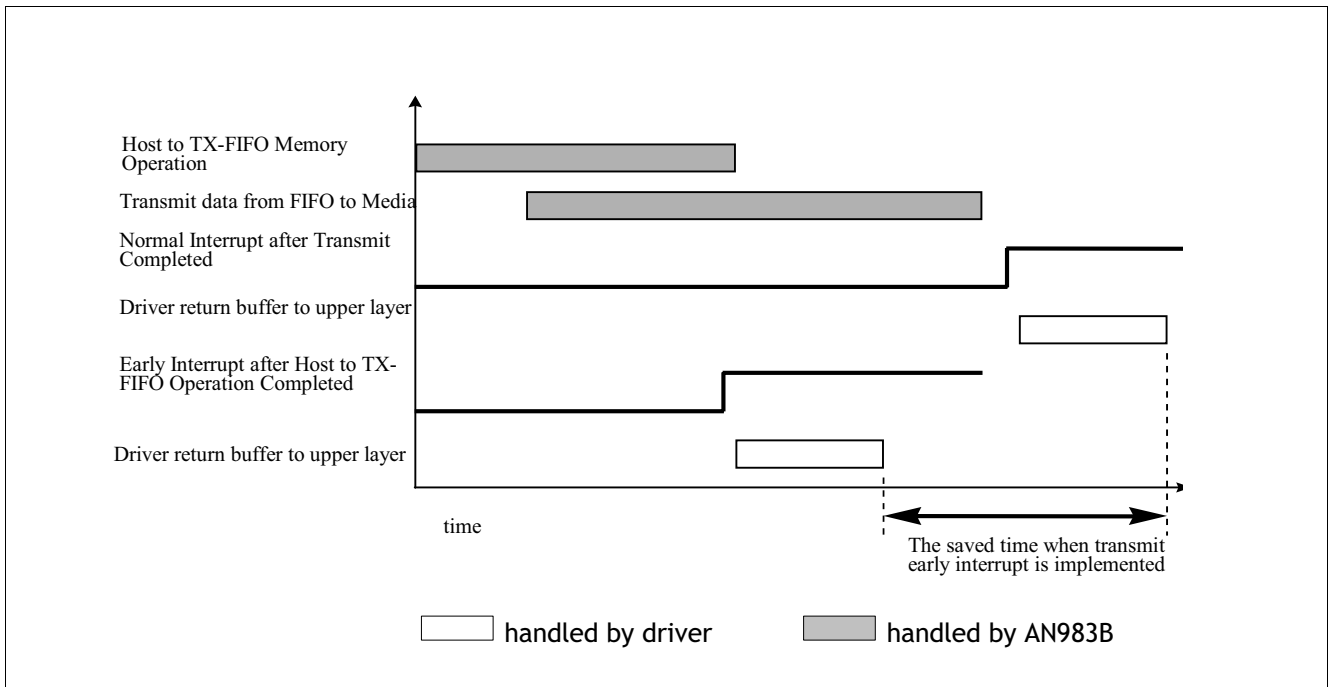

Figure 11 Transmit Normal Interrupt and Early Interrupt Comparison

## 7.4 Receive Scheme and Receive Early Interrupt Scheme

The following figure shows the difference of timing without early interrupt and with early interrupt.



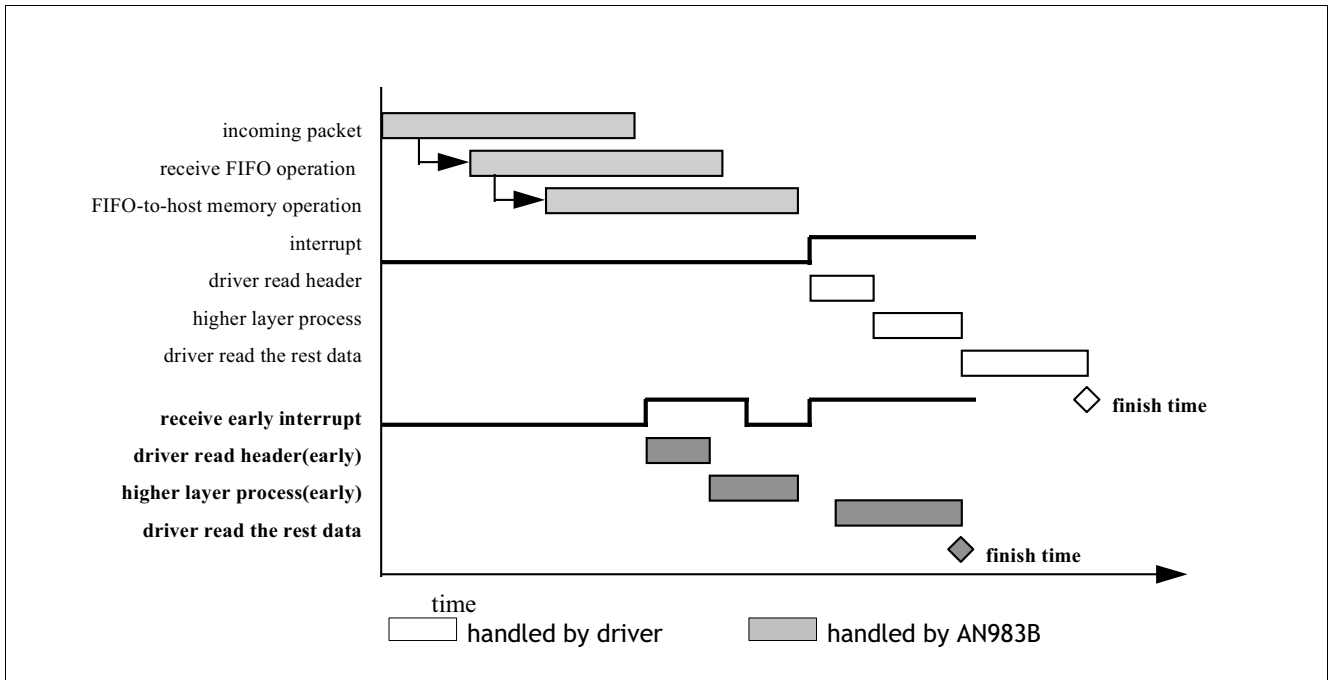

Figure 12 Receive Data Flow (without early interrupt and with early interrupt)

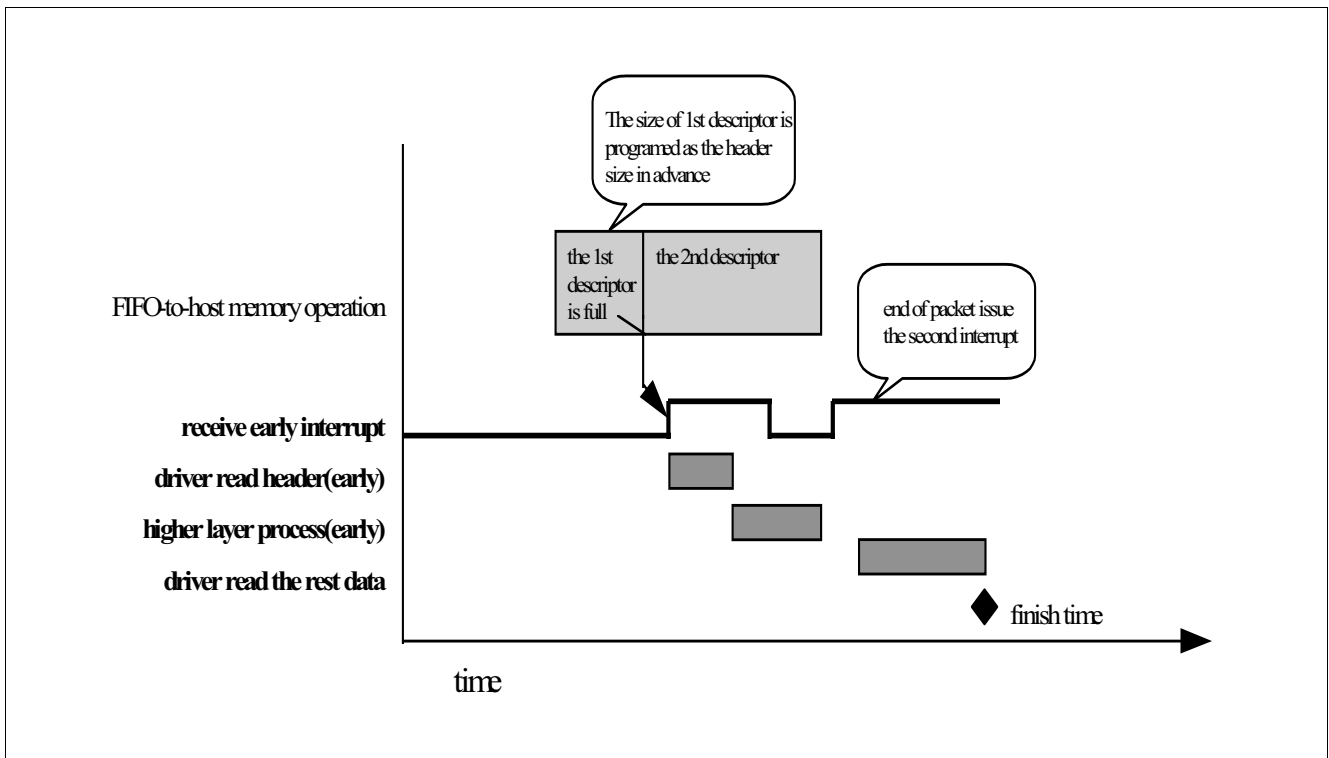

Figure 13 Detailed Receive Early Interrupt Flow

## 7.5 Network Operation

### 7.5.1 MAC Operation

In the MAC (Media Access Control) portion of AN983B/BX, it incorporates the essential protocol requirements for operating as an IEEE802.3 and Ethernet compliant node.

**Table 4 Format**

Field	Description
Preamble	A 7-byte field of (10101010b)
Start Frame Delimiter	A 1-byte field of (10101011b)
Destination Address	A 6-byte field
Source Address	A 6-byte field
Length/Type	A 2-byte field indicated the frame is in IEEE802.3 format or Ethernet format. IEEE802.3 format: 0000H ~ 05DCH for Length field Ethernet format: 05DD ~ FFFFH for Type field
Data	46 <sup>1)</sup> ~ 1500 bytes of data information
CRC	A 32-bit cyclic redundant code for error detection

1) If padding is disabled (TDES1 bit23), the data field may be shorter than 46 bytes.

#### Transmit Data Encapsulation

The differences between the encapsulation and a MAC frame while operating in the 100BASE-TX mode are listed as follow:

1. The first byte of the preamble is replaced by the JK code according to the IEEE802.3u, clause 24.
2. After the CRC field of the MAC frame, the AN983B/BX inserts the TR code according to the IEEE802.3u, clause 24.

#### Receive Data Decapsulation

When operating in 100BASE-TX mode the AN983B/BX detects a JK code for a preamble as well as a TR code for the packet end. If a JK code is not detected, the AN983B/BX will abort this frame receiving and wait for a new JK code detection. If a TR code is not detected, the AN983B/BX will report a CRC error.

#### Deferring

The Inter-Frame Gap (IFG) time is divided into two parts:

1. IFG1 time (64-bit time): If a carrier is detected on the medium during this time, the AN983B/BX will reset the IFG1 time counter and restart to monitor the channel for an idle again.
2. IFG2 time (32-bit time): After counting the IFG2 time the AN983B/BX will access the channel even though a carrier has been sensed on the network.

#### Collision Handling

The scheduling of re-transmissions is determined by a controlled randomization process called "truncated binary exponential back-off". At the end of enforcing a collision (jamming), the AN983B/BX delays before attempting to re-transmit the packet. The delay is an integer multiple of slot time. The number of slot times to delay before the nth re-transmission attempt is chosen as a uniform distributed integer in the range:

$$0 \leq r < 2^k, \text{ where } k = \min. (n, 10)$$

## 7.5.2 Transceiver Operation

In the transceiver portion of the AN983B/BX, it integrates the IEEE802.3u compliant functions of PCS (physical coding sub-layer), PMA (physical medium attachment) sub-layer, PMD (physical medium dependent) sub-layer for 100BASE-TX, the IEEE802.3 compliant functions of Manchester encoding/decoding, and transceiver for 10BASE-T. All the functions and operation schemes are described in the following sections.

### 100BASE-TX Transmit Operation

Regarding to the 100BASE-TX transmission, the transceiver provides the transmission functions of PCS, PMA, and PMD for encoding of MII data nibbles to five-bit code-groups (4B/5B), scrambling, serialization of scrambled code-groups, converting the serial NRZ code into NRZI code, converting the NRZI code into MLT3 code, and then driving the MLT3 code into the category 5 Unshielded Twisted Pair cable through an isolation transformer with the turns ratio of 1:1.

### Data Code-Groups Encoder

In normal MII mode application, the transceiver receives nibble type 4B data via the TxD0~3 inputs of the MII. These inputs are sampled by the transceiver on the rising edge of Tx-clk and passed to the 4B/5B encoder to generate the 5B code-group used by 100BASE-TX.

### Idle Code-Groups

In order to establish and maintain the clock synchronization, the transceiver needs to keep transmitting signals to medium. The transceiver will generate Idle code-groups for transmission when there is no real data MAC that wants to send.

### Start-of-Stream Delimiter-SSD (/J/K/)

In a transmission stream, the first 16 nibbles are MAC preamble. In order to let partner delineate the boundary of a data transmission sequence and to authenticate carrier events, the transceiver will replace the first 2 nibbles of the MAC preamble with /J/K/ code-groups.

### End-of-Stream Delimiter-ESD (/T/R/)

In order to indicate the termination of the normal data transmissions, the transceiver will insert 2 nibbles of /T/R/ code-group after the last nibble of FCS.

### Scrambling

All the encoded data (including the idle, SSD, and ESD code-groups) is passed to data scrambler to reduce the EMI and spread the power spectrum using a 10-bit scrambler seed loaded at the beginning.

### Data Conversion of Parallel to Serial, NRZ to NRZI, NRZI to MLT3

After scrambled, the transmission data with 5B type in 25 MHz it will be converted to serial bit stream in 125 MHz by the parallel to serial function. After serialized, the transmission serial bit stream will be further converted from NRZ to NRZI format. After NRZI converted, the NRZI bit stream is passed through MLT3 encoder to generate the TP-PMD specified MLT3 code. With this MLT3 code, it lowers the frequency and reduces the energy of the transmission signal in the UTP cable and also makes the system easily to meet the FCC specification of EMI.

### Wave-Shaper and Media Signal Driver

In order to reduce the energy of the harmonic frequency of transmission signals, the transceiver provides the wave-shaper prior the line driver to smooth but keep symmetric the rising/falling edge of transmission signals. The wave-shaped signals including the 100BASE-TX and 10BASE-T both are passed to the same media signal driver. This design can simplify the external magnetic connection with single one.

### 100BASE-TX Receiving Operation

Regarding the 100BASE-TX receiving operation, the transceiver provides the receiving functions of PMD, PMA, and PCS for receiving incoming data signals through category 5 UTP cable and an isolation transformer with turns ratio of 1: 1. It includes the adaptive equalizer, baseline wander, data conversions of MLT3 to NRZI, NRZI to NRZ, and serial to parallel, the PLL for clock and data recovery, the de-scrambler, and the decoder of 5B/4B.

#### Adaptive Equalizer and Baseline Wander

The high-speed signals over the unshielded (or shielded) twisted Pair cable will induce the amplitude attenuation and phase shifting. Furthermore, these effects are dependent on the signal frequency, cable type, cable length and the connectors of the cabling. So a reliable adaptive equalizer and baseline wander to compensate all the amplitude attenuation and phase shifting are necessary. In the transceiver, it provides the robust circuits to perform these functions.

#### MLT3 to NRZI Decoder and PLL for Data Recovery

After receiving the proper MLT3 signals, the transceiver converts the MLT3 to NRZI code for further processing. After adaptive equalizer, baseline wander, and MLT3 to NRZI decoder, the compensated signals with NRZI type in 125 MHz are passed to the Phase Lock Loop circuits to extract out the original data and the synchronous clock.

#### Data Conversions of NRZI to NRZ and Serial to Parallel

After data recovered, the signals will be passed to the NRZI to NRZ converter to generate the 125 MHz serial bit stream. This serial bit stream will be packed to parallel 5B type for further processing.

#### De-scrambling and Decoding of 5B/4B

The parallel 5B type data is passed to de-scrambler and 5B/4B decoder to return their original MII nibble type data.

#### Carrier Sensing

Carrier Sense (CRS) signal is asserted when the transceiver detects any 2 non-contiguous zeros within any 10bit boundary of the receiving bit stream. CRS is de-asserted when ESD code-group or Idle code-group is detected. In half duplex mode, CRS is asserted during packet transmission or reception. But in full duplex mode, CRS is asserted only during packet reception.

### 10BASE-T Transmission Operation

It includes the parallel to serial converter, Manchester Encoder, Link test function, Jabber function, the transmit wave-shaper, and line driver described in the section of "Wave-Shaper and Media Signal Driver" of "10BASE-T Transmission Operation". It also provides Collision detection and SQE test for half duplex application.

### 10BASE-T Receive Operation

It includes the carrier sense function, receiving filter, PLL for clock and data recovering, Manchester decoder, and serial to parallel converter.

#### Loop-back Operation of Transceiver

The transceiver provides internal loop-back (also called transceiver loop-back) operation for both the 100BASE-TX and 10BASE-T operations. Setting bit 14 of PHY register 0 to 1 can enable the loop-back operation. In this loop-back operation, PHY will not transmit packets (but PHY will still send MLT3 for Idle).

In the 100BASE-TX internal loop-back operation, the data comes from the transmit output of NRZ to NRZI converter then loop-back to the receiving path into the input of NRZI to NRZ converter.

In the 10BASE-T loop-back operation, the data is through transmitting path and loop-back from the output of the Manchester encoder into the input of Phase Lock Loop circuit of receiving path.

### Full Duplex and Half Duplex Operation of Transceiver

The transceiver can operate for either full duplex or half duplex network application. In full duplex, both transmission and reception can be operated simultaneously. Under full duplex mode, collision (COL) signal is ignored and carrier sense (CRS) signal is asserted only when the transceiver is receiving.

In half duplex mode, either transmission or reception can be operated at one time. Under half duplex mode, collision signal is asserted when transmitted and received signals collided and carrier sense asserted during transmission and reception.

### Auto-Negotiation Operation

The Auto-Negotiation function is designed to provide the means to exchange information between the transceiver and the network partner to automatically configure both to take maximum advantage of their abilities, and both are setup accordingly. The Auto-Negotiation function can be controlled through bit 12 of PHY register 0.

The Auto-Negotiation exchanges information with the network partner using the Fast Link Pulses (FLPs) - a burst of link pulses. There are 16 bits of signaling information contained in the burst pulses to advertise all remote partners' capabilities, which are determined by PHY, register 4. According to this information they find out their highest common capability by following the priority sequence as below:

1. 100BASE-TX full duplex
2. 100BASE-TX half duplex
3. 10BASE-T full duplex
4. 10BASE-T half duplex

During power-up or reset, if Auto-Negotiation is found enabled, FLPs will be transmitted and the Auto-Negotiation function will process. Otherwise, the Auto-Negotiation will not occur until the bit 12 of PHY register 0 is set to 1. When the Auto-Negotiation is disabled, the Network Speed and Duplex Mode are selected by programming PHY register 0.

### Power Down Operation

To reduce the power consumption the transceiver is designed with power down feature, which can save the power consumption significantly. Since the power supply of the 100BASE-TX and 10BASE-T circuits are separated, the transceiver can turn off the circuit of either the 100BASE-TX or 10BASE-T when the other one of them is operating.

### 7.5.3 Flow Control in Full Duplex Application

The PAUSE function operation is used to inhibit transmission of data frames for a specified period of time. The AN983B/BX supports full duplex protocol of IEEE802.3x. To support PAUSE function, the AN983B/BX implements the MAC Control Sub-layer functions to decode the MAC Control frames received from MAC control clients and execute the relative requests accordingly. When the Full Duplex mode and PAUSE function are selected after Auto-Negotiation completed, the AN983B/BX enables the PAUSE function for flow control of full duplex application. In this section we will describe how the AN983B/BX implements the PAUSE function.

**MAC Control Frame and PAUSE Frame**

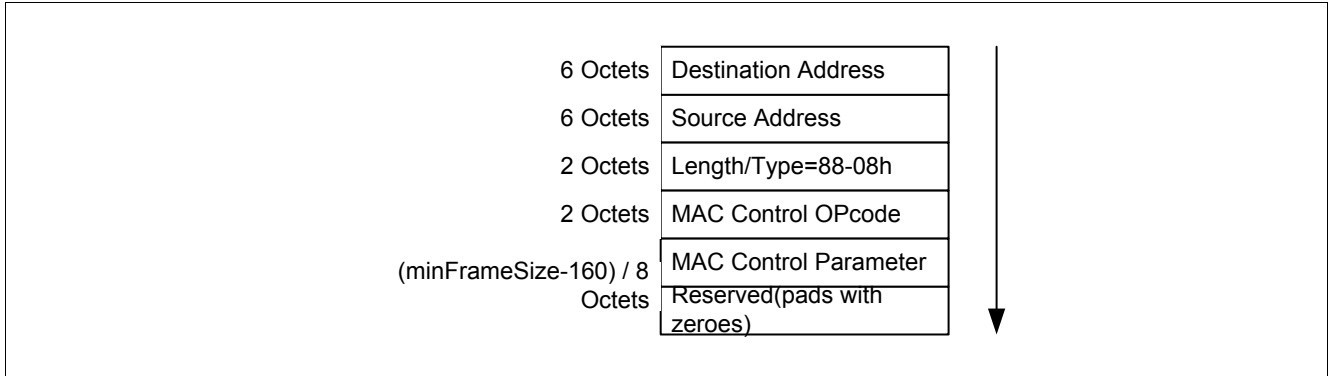

**Figure 14 MAC Control Frame Format**

The MAC Control frame is distinguished from other MAC frames only by their Length/Type field identifier. The MAC Control Opcode defined in MAC Control Frame format for PAUSE function is 0001h. Besides, the PAUSE time is specified in the MAC Control Parameters field with 2 Octets, unsigned integer, in the units of Slot-Times. The range of possible PAUSE time is 0 to 65535 Slot-Times.

So, a valid PAUSE frame issued by a MAC control client (could be a switch or a bridge) will contain:

1. The destination address is set equal to the globally assigned 48 bit mulitcast address 01-80-C2-00-00-01, or equal to the unicast address which the MAC control client wishes to inhibit its transmission of data frames.
2. Filled the MAC Control Opcode field with 0001<sub>H</sub>.
3. 2 Octets of PAUSE time specified in the MAC Control parameter field to indicate the length of time for which the destination is wished to inhibit data frame transmission.

**Receive Operation for PAUSE Function**

Upon reception of a valid MAC Control frame, the AN983B/BX will start a timer for the length of time specified by the MAC Control Parameters field. When the timer value reaches zero then the AN983B/BX ends PAUSE state. However, a PAUSE frame should not affect the transmission of a frame that has been submitted to the MAC (started Transmit out of the MAC and can't be interrupted). On the other hand, the AN983B/BX shall not begin to transmit a frame more than one Slot-Times after received a valid PAUSE frame with a non-zero PAUSE time. If the AN983B/BX receives a PAUSE frame with a zero PAUSE time value, the AN983B/BX ends the PAUSE state immediately.

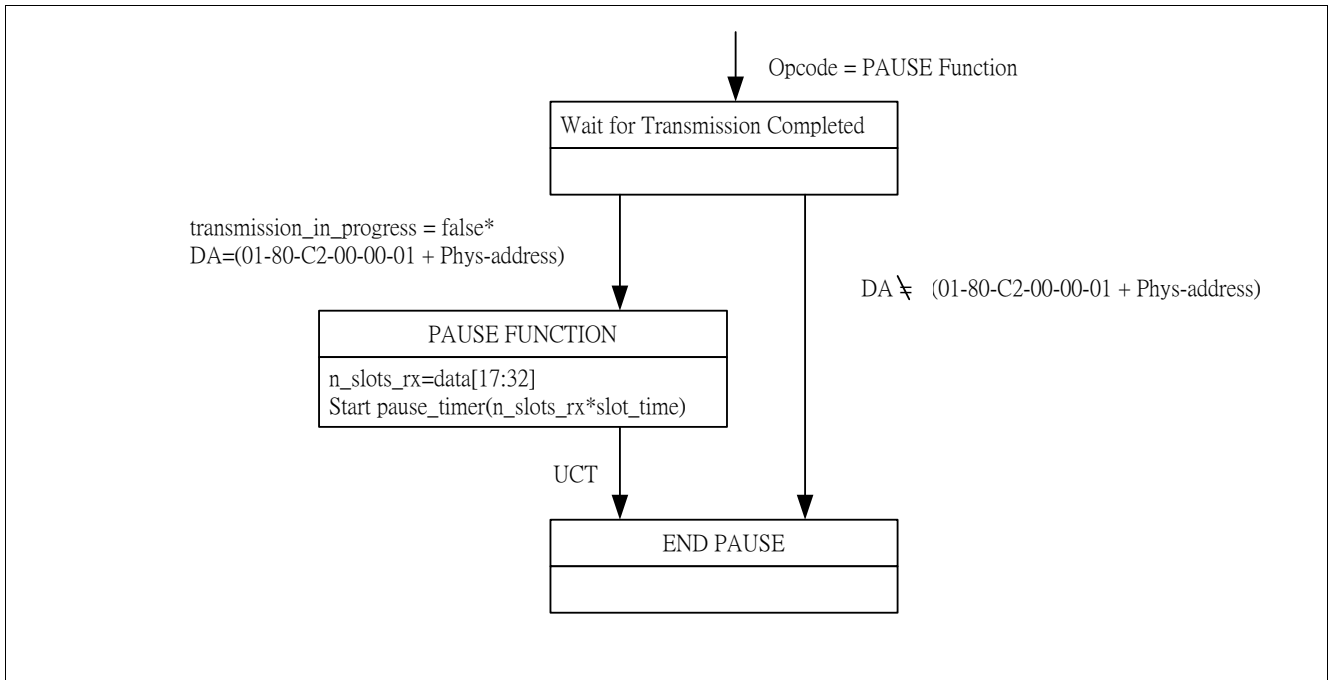

Figure 15 PAUSE Operation Receive State Diagram

## 7.6 LED Display Operation

The AN983B/BX provides 2 kinds of LED display mode; the detailed descriptions about the operation are described in the PIN Description section.

### 7.6.1 First Mode – 3 LED Displays

for

- 100 Mbit/s(on) or 10 Mbit/s(off)
- Link (Keeps on when link ok) or Activity (Blink with 10 Hz when receiving or transmitting but not collision)
- FD (Keeps on when in Full duplex mode) or Collision (Blink with 20 Hz when colliding)

### 7.6.2 Second Mode – 4 LED Displays

for

- 100 Link (On when 100M link ok)
- 10 Link (On when 10M link ok)
- Activity (Blink with 10 Hz when receiving or transmitting)
- FD (Keeps on when in Full duplex mode) or Collision (Blink with 20 Hz when colliding)

## 7.7 Reset Operation

### 7.7.1 Reset Whole Chip

There are two ways to reset the AN983B/BX. First, hardware reset, the AN983B/BX can be reset via  $\overline{\text{RST}}$  pin. For ensuring proper reset operation, at least 100s active Reset input signal is required. Second, software reset, when bit 0 of CSR0 register is set to 1, the AN983B/BX will reset entire circuits and registers to default value then clear the bit 0 of CSR0 to 0.

### 7.7.2 Reset Transceiver Only

When bit 15 of PHY register 0 is set to 1, the transceiver will reset entire circuits and register contents to default value then clear the bit 15 of PHY register 0 to 0.

## 7.8 Wake on LAN Function

The AN983B/BX can assert a signal to wake up the system when it received a Magic Packet from the network. The Wake on LAN operation is described as follow.

### 7.8.1 The Magic Packet Format

- Valid destination address that can pass the address filter of the AN983B/BX
- The payload of frame must include at least 6 contiguous 'FF' followed immediately by 16 repetitions of IEEE address.
- The frame can contain multiple 'six FF + sixteen IEEE address' pattern.
- CRC OK

### 7.8.2 The Wake on LAN Operation

The Wake on LAN enable function is controlled by bit 18 of CSR18; it is loaded from EEPROM after reset or programmed by driver to enable Wake on LAN function. If the bit 18 of CSR18 is set and the AN983B/BX receive



a Magic Packet, it will assert the PME# signal (drive to low) to indicate receiving a wake up frame as well as to set the PME status bit (the bit 15 of CSR20).

## 7.9 ACPI Power Management Function

The AN983B/BX has a built-in capability for Power Management (PM), which controlled by the host system. The AN983B/BX will provide:

- Compatibility with Device Class Power Management Reference Specification, Rev1.09
- Compatibility with ACPI specification, Rev 1.0
- Compatibility with PCI Bus Power Management Interface Specification, Rev 1.1
- Compatibility with AMD Magic Packet™ Technology.
- Compatibility with PCI CLKRUN scheme.

### 7.9.1 Power States

#### D0 (Fully On)

In this state the AN983B/BX operates as full functionality and consumes its normal power. While in the D0 state, if the PCI clock is lower than 16 MHz, the AN983B/BX may not receive or transmit frames properly.

#### D1

In this state the AN983B/BX doesn't response to any accesses, except configuration space and full function context in place. The only network operation the AN983B/BX can initiate is a wake-up event.

#### D2

In this state the AN983B/BX only responds to access configuration space and full function context in place. The AN983B/BX can't transmit or receive even the wake-up frame.

#### D3<sub>cold</sub> (Power Removed)

In this state all function context is lost. When power is restored, the function will return to D0.

#### D3<sub>hot</sub> (Software Visible D3)

When the AN983B/BX is brought back to D0 from D3<sub>hot</sub> the software must perform a full initialization.

The AN983B/BX in the D3<sub>hot</sub> state responds to configuration cycles as long as power and clock are supplied. This requires the device to perform an internal reset and return to a power-up reset condition without the RST# pin asserted.

**Table 5 Power State**

Device State	PCI-Bus State	Function Context	Clock	Power	Supported Actions to Function	Supported Actions from Function
D0	B0	Full function context in place	Full speed	Full power	Any PCI transaction	Any PCI transaction or interrupt
D1	B0, B1	Configuration maintained. No Tx and Rx except wake-up events	Stopped to Full speed	–	PCI configuration access	Only wake-up events

## Functional Descriptions

**Table 5 Power State (cont'd)**

Device State	PCI-Bus State	Function Context	Clock	Power	Supported Actions to Function	Supported Actions from Function
D2	B0, B1, B2	Configuration maintained. No Tx and Rx	Stopped to Full speed	–	PCI configuration access (B0, B1)	–
D3hot	B0, B1, B2	Configuration lost, full initialization required upon return to D0	Stopped to Full speed	–	PCI configuration access (B0, B1)	–
D3cold	B3	All configurations lost. Power-on defaults in place on return to D0	No clock	No power	Power-on reset	–

## 8 General EEPROM Format Description

**Table 6 Connection Type Definition**

Offset	Length	Description
0	2	AN983B/BX Signature: 0x85, 0x09, AN985 Signature: 0x85, 0x19
2	1	Format major version: 0x02
3	1	Format minor version: 0x00
4	4	Reserved
8	6	IEEE network address: ID1, ID2, ID3, ID4, ID5, ID6
E	1	Reserved, should be zero.
F	1	Reserved, should be zero.
10	1	Phytype Reserved, should be zero.
11	1	Reserved, should be zero.
12	2	Default Connection Type, see Table 9.1
14	1	BootRom ENABLE = 1, DISABLE = 0
15	1	BootRom Default selection: 0: Using INT 18h 1: Using INT 19h 2: Using Pnp/BEV (BBS) 0x10: Boot From RPL
16	0xA	Reserved, should be zero.
20	2	PCI Device ID: 0X0985 (AN983B/BX), 0x1985(AN985)
22	2	PCI Vendor ID: 0x1317
24	2	PCI Subsystem ID
26	2	PCI Subsystem Vendor ID
28	1	MIN_GNT value. 0xFF
29	1	MAX_LAT value. 0xFF
2A	4	CIS Pointer, it will be loaded into CR10. 0x0202
2E	2	CSR18 (CR) bit 31-16 recall data. Please reference AN983B/BX Spec.
30	0x22	Reserved, should be zero.
52	2	Cardbus CIS length
54	0x2A	Reserved, should be zero.
7E	2	CheckSum, the least significant two bytes of FCS for data stored in offset 0.7D of EEPROM
140	C0	Cardbus CIS
0xFFFF		Software Driver Default
0x0100		Auto-Negotiation
0x0200		Power-on Auto-detection
0x0400		Auto Sense
0x0000		10BaseT
0x0001		BNC

---

**General EEPROM Format Description**

0x0002	AUI
0x0003	100BaseTx
0x0004	100BaseT4
0x0005	100BaseFx
0x0010	10BaseT Full Duplex
0x0013	100BaseTx Full Duplex
0x0015	100BaseFx Full Duplex

## 9 Registers and Descriptors Description

There are three kinds of registers designed for AN983B/BX. They are AN983B/BX configuration registers, PCI control/status registers, and Transceiver control/status registers.

The AN983B/BX configuration registers are used to initialize and configure the AN983B/BX for identifying and querying the AN983B/BX.

The PCI control/status registers are used to communicate between the host and AN983B/BX. Host can initialize, control, and read the status of the AN983B/BX through the mapped I/O or memory address space.

Regarding the registers of transceiver portion of AN983B/BX, it includes 7 basic registers which are defined according to the clause 22 "Reconciliation Sub-layer and Media Independent Interface" and clause 28 "Physical Layer link signaling for 10 Mbit/s and 100 Mbit/s Auto-Negotiation on twisted pair" of IEEE802.3u standard. The AN983B/BX also provides receive and transmit descriptors for packet buffering and management. These descriptors are described in the following section.

## 9.1 AN983B/BX Configuration Registers

**Table 7 Registers Address Space**

Module	Base Address	End Address	Note
xxxxx	1200 0000 <sub>H</sub>	xxxx 0110 <sub>H</sub>	Xxxxx

**Table 8 Registers Overview**

Register Short Name	Register Long Name	Offset Address	Page Number
<a href="#">LID_CR0</a>	Loaded Identification Number	00 <sub>H</sub>	<a href="#">40</a>
<a href="#">CSD_CR1</a>	Configuration Command and Status	04 <sub>H</sub>	<a href="#">40</a>
<a href="#">CC_CR2</a>	Class Code and Revision Number	08 <sub>H</sub>	<a href="#">42</a>
<a href="#">LT_CR3</a>	Latency Timer	0C <sub>H</sub>	<a href="#">42</a>
<a href="#">IOBA_CR4</a>	I/O Base Address	10 <sub>H</sub>	<a href="#">43</a>
<a href="#">MBA_CR5</a>	Memory Base Address	14 <sub>H</sub>	<a href="#">44</a>
<a href="#">CIS_CR10</a>	Card Information Structure	28 <sub>H</sub>	<a href="#">44</a>
<a href="#">SID_CR11</a>	Subsystem ID and Vendor ID	2C <sub>H</sub>	<a href="#">44</a>
<a href="#">BRBA_CR12</a>	Boot ROM Base Address	30 <sub>H</sub>	<a href="#">45</a>
<a href="#">CP_CR13</a>	Capabilities Pointer	34 <sub>H</sub>	<a href="#">45</a>
<a href="#">CI_CR15</a>	Configuration Interrupt	3C <sub>H</sub>	<a href="#">46</a>
<a href="#">DS_CR16</a>	Driver Space for Special Purpose	40 <sub>H</sub>	<a href="#">47</a>
<a href="#">SIG_CR32</a>	Signature	80 <sub>H</sub>	<a href="#">47</a>
<a href="#">PMR0_CR48</a>	Power Management Register 0	C0 <sub>H</sub>	<a href="#">48</a>
<a href="#">PMR1_CR49</a>	Power Management Register 1	C4 <sub>H</sub>	<a href="#">49</a>

The register is addressed wordwise.

**Table 9 Registers Access Conditions Registers Access Conditions**

Access Condition Short Name	Dependency
	= B.

Standard abbreviations:

**Table 10 Registers Access Types**

Mode	Symbol	Description Hardware (HW)	Description Software (SW)
read/write	rw	Register is used as input for the HW	Register is read and writable by SW
read	r	Register is written by HW (register between input and output -> one cycle delay)	Value written by software is ignored by hardware; that is, software may write any value to this field without affecting hardware behavior (= Target for development.)
write	w		Register is writable by SW
read/write hardware affected	rwh	Register can be modified by HW	Register can be modified by HW, but the priority SW versus HW has to be specified
	rwv		

**Registers and Descriptors Description AN983B/BX Configuration Registers**
**Table 10 Registers Access Types (cont'd)**

Mode	Symbol	Description Hardware (HW)	Description Software (SW)
Read only	ro	Register is set by HW (register between input and output -> one cycle delay)	SW can only read this register
Read virtual	rv	Physically, there is no new register, the input of the signal is connected directly to the address multiplexer.	SW can only read this register
Latch high, self clearing	lhsc	Latch high signal at high level, clear on read	SW can read the register
Latch low, self clearing	llsc	Latch high signal at low-level, clear on read	SW can read the register
Latch high, mask clearing	lhmk	Latch high signal at high level, register cleared with written mask	SW can read the register, with write mask the register can be cleared (1 clears)
Latch low, mask clearing	llmk	Latch high signal at low-level, register cleared on read	SW can read the register, with write mask the register can be cleared (1 clears)
Interrupt high, self clearing	ihsc	Differentiate the input signal (low->high) register cleared on read	SW can read the register
Interrupt low, self clearing	ilsc	Differentiate the input signal (high->low) register cleared on read	SW can read the register
Interrupt high, mask clearing	ihmk	Differentiate the input signal (high->low) register cleared with written mask	SW can read the register, with write mask the register can be cleared
Interrupt low, mask clearing	ilmk	Differentiate the input signal (low->high) register cleared with written mask	SW can read the register, with write mask the register can be cleared
Interrupt enable register	ien	Enables the interrupt source for interrupt generation	SW can read and write this register
latch_on_reset	lor	rw register, value is latched after first clock cycle after reset	Register is read and writable by SW
Read/write self clearing	rwsc	Register is used as input for the hw, the register will be cleared due to a HW mechanism.	Writing to the register generates a strobe signal for the HW (1 pdi clock cycle) Register is read and writable by SW.

**Table 11 Registers Clock Domains**

Clock Short Name	Description

**9.1.1 AN983B/BX Configuration Registers Descriptions**

Offset	b31-----b16	b15-----b0
00h	Device ID*	Vendor ID*
04h	Status	Command
08h	Base Class Code	Subclass
0ch	-----	-----
		Latency timer
		Cache line size
		Revision#
		Step#

Registers and Descriptors Description AN983B/BX Configuration Registers

Offset	b31-----b16	b15-----b0
10h	Base I/O address	
14h	Base memory address	
18h~24h	Reserved	
28h	ROM-im*	Address space offset* Add-indi*
2ch	Subsystem ID*	Subsystem vendor ID*
30h	Boot ROM base address	
34h	Reserved	
38h	Reserved	
3ch	Max_Lat*	Min_Gnt* Interrupt pin Interrupt line
40h	Reserved	Driver Space Reserved
80h	Signature of AN983B/BX	
c0h	PMC	Next_Item_Pt r Cap_ID
c4h	Reserved	PMCSR

Note: Automatically recalled from EEPROM when PCI reset is deserted.

1. CIS(28h) is a read-only register.
2. DS(40h), bit 15-8, is read/write able register.
3. SIG(80h) is hard wired register, read only.

Loaded Identification Number of Device and Vendor

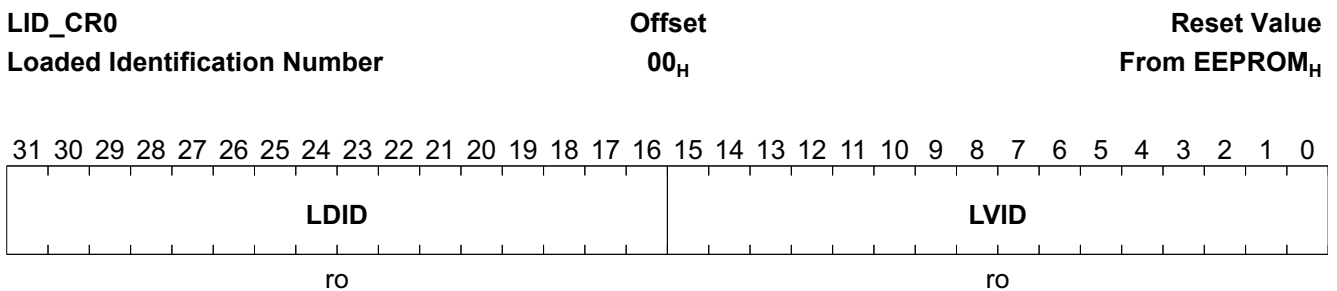

Field	Bits	Type	Description
LDID	31:16	ro	<b>Loaded Device ID</b> The device ID number loaded from serial EEPROM.
LVID	15:0	ro	<b>Loaded Vendor ID</b> The vendor ID number loaded from serial EEPROM.

Reset Value loaded from EEPROM

Configuration Command and Status



**Registers and Descriptors Description AN983B/BX Configuration Registers**

<b>CSD_CR1</b>	<b>Offset</b>	<b>Reset Value</b>
<b>Configuration Command and Status</b>	<b>04<sub>H</sub></b>	<b>0290 0000<sub>H</sub></b>

31	30	29	28	27	26	25	24	23	22	21	20	19	18	17	16	15	14	13	12	11	10	9	8	7	6	5	4	3	2	1	0	
<b>SP</b>	<b>SE</b>	<b>SM</b>	<b>ST</b>	<b>Re</b>	<b>SD</b>	<b>SD</b>	<b>SF</b>	<b>Res</b>	<b>NC</b>														<b>CS</b>	<b>Re</b>	<b>CP</b>							
<b>E</b>	<b>S</b>	<b>A</b>	<b>A</b>	<b>s</b>	<b>ST</b>	<b>PR</b>	<b>BB</b>																<b>E</b>	<b>s</b>	<b>E</b>							
rw	rw	rw	rw	ro	ro	rw	ro	ro	ro														rw	ro	rw		ro		rw	rw	rw	

Field	Bits	Type	Description
SPE	31	rw	<b>Status of Parity Error</b> 1 <sub>B</sub> , means that AN983B/BX detected a parity error. This bit will be set in this condition even if the parity error response (bit 6 of CR1) is disabled.
SES	30	rw	<b>Status of System Error</b> 1 <sub>B</sub> , means that AN983B/BX asserted the system error pin
SMA	29	rw	<b>Status of Master Abort</b> 1 <sub>B</sub> , means that AN983B/BX received a master abort and terminated a master transaction
STA	28	rw	<b>Status of Target Abort</b> 1 <sub>B</sub> , means that AN983B/BX received a target abort and terminated a master transaction
Res	27	ro	<b>Reserved</b>
SDST	26:25	ro	<b>Status of Device Select Timing</b> The timing of the assertion of device select. 01 <sub>B</sub> , means a medium assertion of <u>DEVSEL#</u>
SDPR	24	rw	<b>Status of Data Parity Report</b> 1: when three conditions are met: AN983B/BX asserted parity error - <u>PERR#</u> or it detected parity error asserted by other device. AN983B/BX is operating as a bus master. AN983B/BX's parity error response bit (bit 6 of CR1) is enabled.
SFBB	23	ro	<b>Status of Fast Back-to-Back</b> Always 1, since AN983B/BX has the ability to accept fast back-to-back transactions.
Res	22:21	ro	<b>Reserved</b>
NC	20	ro	<b>New Capabilities</b> This bit indicates that whether the AN983B/BX provides a list of extended capabilities, such as PCI power management. 0 <sub>B</sub> , the AN983B/BX doesn't provide New Capabilities 1 <sub>B</sub> , the AN983B/BX provides the PCI management function
Res	19:9	ro	<b>Reserved</b>
CSE	8	rw	<b>Command of System Error Response</b> 1 <sub>B</sub> , enable system error response. AN983B/BX will assert <u>SERR#</u> when it find a parity error on the address phase.
Res	7	ro	<b>Reserved</b>

**Registers and Descriptors Description AN983B/BX Configuration Registers**

Field	Bits	Type	Description
CPE	6	rw	<b>Command of Parity Error Response</b> $0_B$ , disable parity error response. AN983B/BX will ignore any detected parity error and keep on its operating. Default value is 0. $1_B$ , enable parity error response. AN983B/BX will assert system error (bit 13 of CSR5) when a parity error is detected.
Res	5:3	ro	<b>Reserved</b>
CMO	2	rw	<b>Command of Master Operation Ability</b> $0_B$ , disable the bus master ability $1_B$ , enable the PCI bus master ability. Default value is 1 for normal operation.
CMSA	1	rw	<b>Command of Memory Space Access</b> $0_B$ , disable the memory space access ability $1_B$ , enable the memory space access ability
CIOASA	0	rw	<b>Command of I/O Space Access</b> $0_B$ , disable the I/O space access ability $1_B$ , enable the I/O space access ability

rw: Read and Write able. ro: Read able only

**Class Code and Revision Number**

**CC\_CR2** **Offset** **Reset Value**  
**Class Code and Revision Number** **08<sub>H</sub>** **0200 0011<sub>H</sub>**

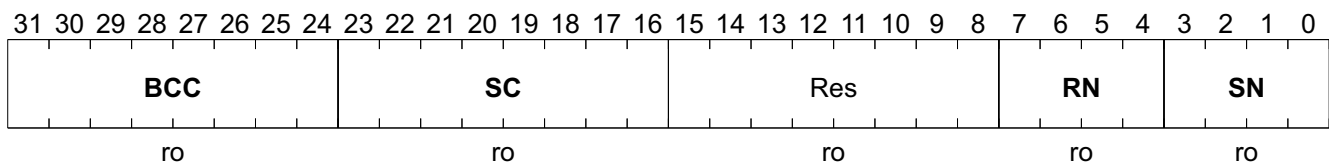

Field	Bits	Type	Description
BCC	31:24	ro	<b>Base Class Code</b> It means AN983B/BX is network controller.
SC	23:16	ro	<b>Subclass Code</b> It means AN983B/BX is a Fast Ethernet Controller.
Res	15:8	ro	<b>Reserved</b>
RN	7:4	ro	<b>Revision Number</b> Identifies the revision number of AN983B/BX.
SN	3:0	ro	<b>Step Number</b> Identifies the AN983B/BX steps within the current revision.

ro: Read only

**Latency Timer**

**Registers and Descriptors Description AN983B/BX Configuration Registers**

**LT\_CR3** **Offset**  
**Latency Timer** **0C<sub>H</sub>** **Reset Value**  
**0000 0000<sub>H</sub>**

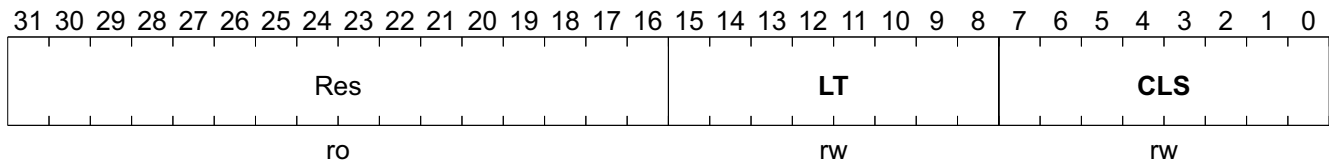

Field	Bits	Type	Description
Res	31:16	ro	<b>Reserved</b>
LT	15:8	rw	<b>Latency Timer</b> This value specifies the latency timer of the AN983B/BX in units of PCI bus clock. Once the AN983B/BX asserts $\overline{\text{FRAME\#}}$ , the latency timer starts to count. If the latency timer expires and the AN983B/BX still asserted $\overline{\text{FRAME\#}}$ , then the AN983B/BX will terminate the data transaction as soon as its $\overline{\text{GNT\#}}$ is removed.
CLS	7:0	rw	<b>Cache Line Size</b> This value specifies the system cache line size in units of 32-bit double words (DW). The AN983B/BX supports 8, 16, and 32 DW of cache line size. This value is used by the AN983B/BX driver to program the cache alignment bits (bit 14 and 15 of CSR0). The cache alignment bits are used for cache oriented PCI commands; say memory-read-line, memory-read-multiple, and memory-write-and-invalidate.

**I/O Base Address**

**IOBA\_CR4** **Offset**  
**I/O Base Address** **10<sub>H</sub>** **Reset Value**  
**0000 0001<sub>H</sub>**

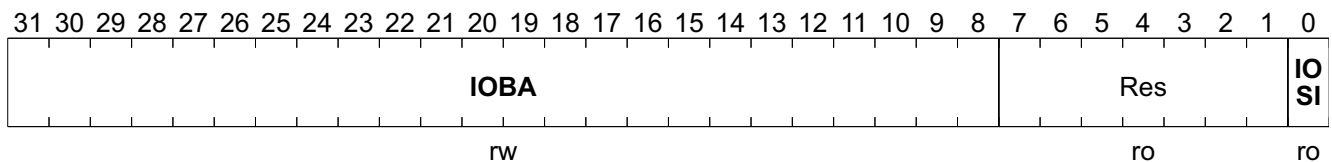

Field	Bits	Type	Description
IOBA	31:8	rw	<b>I/O Base Address</b> This value indicates the base address of PCI control and status register (CSR0~28).
Res	7:1	ro	<b>Reserved</b>
IOSI	0	ro	<b>I/O Space Indicator</b> 1 <sub>B</sub> , means that the configuration registers map into the I/O space

Registers and Descriptors Description AN983B/BX Configuration Registers

**Memory Base Address**

**MBA\_CR5** **Offset**  
**Memory Base Address** **14<sub>H</sub>** **Reset Value**  
**0000 0000<sub>H</sub>**

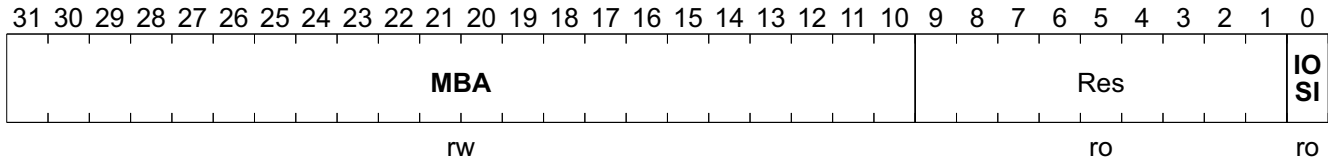

Field	Bits	Type	Description
MBA	31:10	rw	<b>Memory Base Address</b> This value indicates the base address of PCI control and status register (CSR0~28).
Res	9:1	ro	<b>Reserved</b>
IOSI	0	ro	<b>Memory Space Indicator</b> 1 <sub>B</sub> , means that the configuration registers map into the I/O space

**Card Information Structure**

For Card bus.

*Note: Automatically recalled from EEPROM when PCI reset is deserted.*

**CIS\_CR10** **Offset**  
**Card Information Structure** **28<sub>H</sub>** **Reset Value**  
**0000 0000<sub>H</sub>**

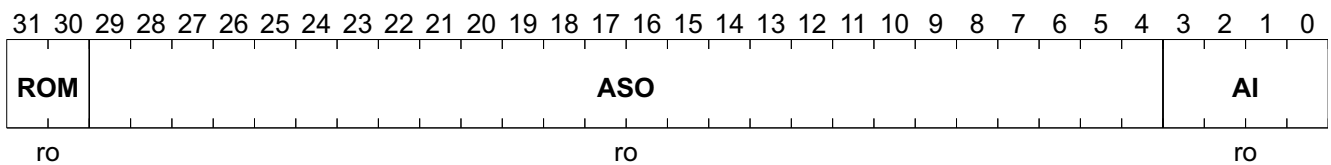

Field	Bits	Type	Description
ROM	31:30	ro	<b>ROM</b> ROM-image
ASO	29:4	ro	<b>Address Space Offset</b>
AI	3:0	ro	<b>Address Space Indicator</b>

**Subsystem ID and Vendor ID**

*Note: Automatically recalled from EEPROM when PCI reset is deserted.*

**SID\_CR11** **Offset**  
**Subsystem ID and Vendor ID** **2C<sub>H</sub>** **Reset Value**  
**1216 1113<sub>H</sub>**

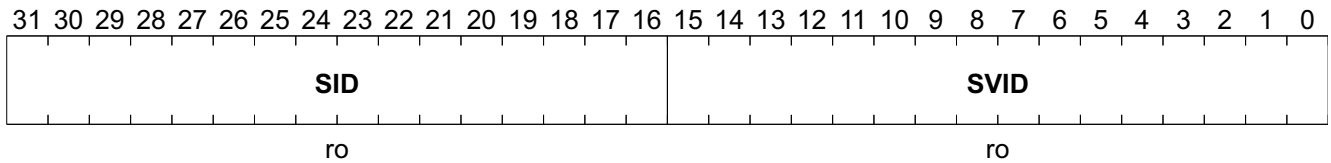
**Registers and Descriptors Description AN983B/BX Configuration Registers**

Field	Bits	Type	Description
SID	31:16	ro	<b>Subsystem ID</b> This value is loaded from EEPROM after power on or hardware reset.
SVID	15:0	ro	<b>Subsystem Vendor ID</b> This value is loaded from EEPROM after power on or hardware reset.

**Boot ROM Base Address**

256 Bytes ROM size.

<b>BRBA_CR12</b>	<b>Offset</b>	<b>Reset Value</b>
<b>Boot ROM Base Address</b>	<b>30<sub>H</sub></b>	<b>XXXX 0000<sub>H</sub></b>

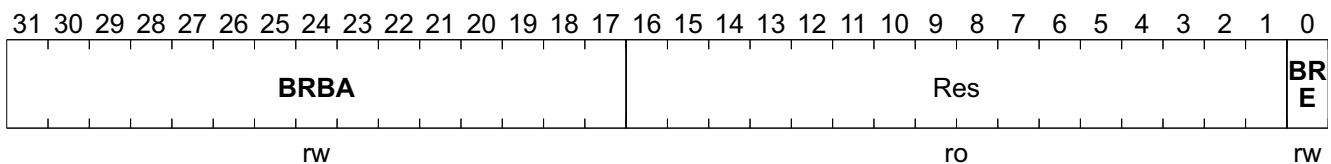

Field	Bits	Type	Description
BRBA	31:17	rw	<b>Boot ROM Base Address</b> This value indicates the address mapping of boot ROM field. Besides, it also defines the boot ROM size. The value of bit 17~10 is set to 0 for AN983B/BX supports up to 256 KB of boot ROM.
Res	16:1	ro	<b>Reserved</b>
BRE	0	rw	<b>Boot ROM Enable</b> The AN983B/BX really enables its boot ROM access only if both the memory space access bit (bit 1 of CR1) and this bit are set to 1. 1 <sub>B</sub> , enable Boot ROM (Combines with bit 1 of CR1)

This register should be initialized before accessing the boot ROM space (write 32'hffffff return 32'h fffe0001)

**Capabilities Pointer**

<b>CP_CR13</b>	<b>Offset</b>	<b>Reset Value</b>
<b>Capabilities Pointer</b>	<b>34<sub>H</sub></b>	<b>0000 00C0<sub>H</sub></b>

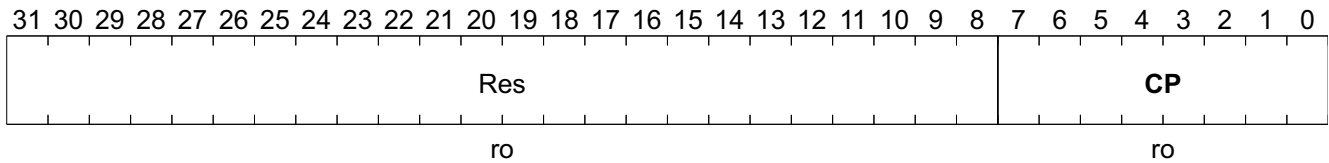
**Registers and Descriptors Description AN983B/BX Configuration Registers**

Field	Bits	Type	Description
Res	31:8	ro	<b>Reserved</b>
CP	7:0	ro	<b>Capabilities Pointer</b>

**Configuration Interrupt**

<b>CI_CR15</b>	<b>Offset</b>	<b>Reset Value</b>
<b>Configuration Interrupt</b>	<b>3C<sub>H</sub></b>	<b>XXXX 01XX<sub>H</sub></b>

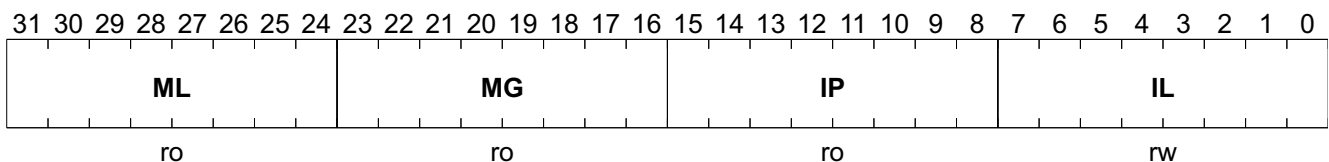

Field	Bits	Type	Description
ML	31:24	ro	<b>Max. Lat Register</b> This value indicates “how often” the AN983B/BX needs to access to the PCI bus in the units of 250 ns. This value is loaded from serial EEPROM after power on or hardware reset. <i>Note: Automatically recalled from EEPROM when PCI reset is deserted.</i>
MG	23:16	ro	<b>Min. Gnt Register</b> This value indicates how long the AN983B/BX needs to retain the PCI bus ownership whenever it initiates a transaction, in the units of 250 ns. This value is loaded from serial EEPROM after power on or hardware reset. <i>Note: Automatically recalled from EEPROM when PCI reset is deserted.</i>
IP	15:8	ro	<b>Interrupt Pin</b> This value indicates which of the four interrupt request pins that AN983B/BX is connected. Always 01h: means the AN983B/BX connects to INTA#
IL	7:0	rw	<b>Interrupt Line</b> This value indicates which of the system interrupt request lines the INTA# of AN983B/BX is routed to. The BIOS will fill this field when it initializes and configures the system. The AN983B/BX driver can use this value to determine priority and vector information.

**Driver Space for Special Purpose**

<b>DS_CR16</b>	<b>Offset</b>	<b>Reset Value</b>
<b>Driver Space for Special Purpose</b>	<b>40<sub>H</sub></b>	<b>0000 XX00<sub>H</sub></b>

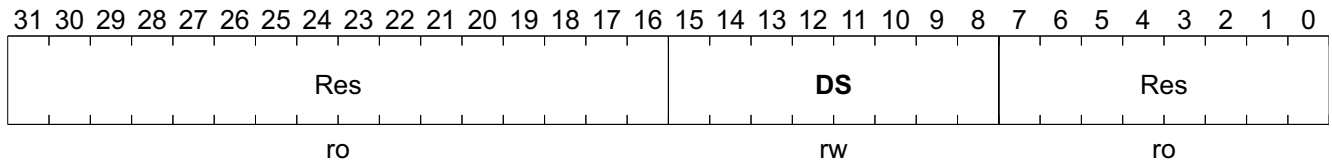

Field	Bits	Type	Description
Res	31:16	ro	<b>Reserved</b>
DS	15:8	rw	<b>Driver Space for special purpose</b> Since this area won't be cleared in the software reset, the AN983B/BX driver can use this rw area for special purpose.
Res	7:0	ro	<b>Reserved</b>

**Signature of AN983B/BX**

Hard wired register, read only

<b>SIG_CR32</b>	<b>Offset</b>	<b>Reset Value</b>
<b>Signature</b>	<b>80<sub>H</sub></b>	<b>0981 1317<sub>H</sub></b>

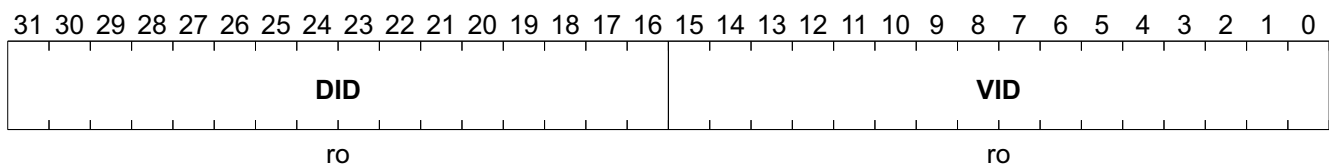

Field	Bits	Type	Description
DID	31:16	ro	<b>Device ID</b> The device ID number of AN983B/BX.
VID	15:0	ro	<b>Vendor ID</b> The vendor ID number of ADM Technology Corp.

**Registers and Descriptors Description AN983B/BX Configuration Registers**
**Power Management Register 0**

<b>PMR0_CR48</b>	<b>Offset</b>	<b>Reset Value</b>
<b>Power Management Register 0</b>	<b>C0<sub>H</sub></b>	<b>FE82 0001<sub>H</sub></b>

31	30	29	28	27	26	25	24	23	22	21	20	19	18	17	16	15	14	13	12	11	10	9	8	7	6	5	4	3	2	1	0
<b>PMES</b>				<b>D2</b>	<b>D1</b>	<b>AUXC</b>			<b>DS</b>	<b>Re</b>	<b>PM</b>	<b>VER</b>				<b>NIP</b>				<b>CAPID</b>											
ro				ro	ro	ro			ro	ro	ro	ro				ro				ro											

Field	Bits	Type	Description
PMES	31:27	ro	<b>PME Support</b> The AN983B/BX will assert $\overline{\text{PME\#}}$ signal while in the D0, D1, D2, D3 power state. The AN983B/BX supports Wake-up from the above states.
D2S	26	ro	<b>D2 Support</b> The AN983B/BX supports D2 Power Management State.
D1S	25	ro	<b>D1 Support</b> The AN983B/BX supports D1 Power Management State.
AUXC	24:22	ro	<b>Aux Current</b> These three bits report the maximum 3.3 V <sub>aux</sub> current requirements for AN983B/BX. If bit 31 of PMR0 is '1', the default value is 0101b, means AN983B/BX need 100 mA to support remote wake-up in D3 cold power state.
DSI	21	ro	<b>Device Specific Initialization</b> The Device Specific Initialization bit indicates whether special initialization of this function is required before the generic class device driver is able to use it. $0_B$ , indicates that the function does not require a device specific initialization sequence following transition to the D0 un-initialized state
Res	20	ro	<b>Reserved</b>
PMEC	19	ro	<b>PME Clock</b> When "1" indicates that the AN983B/BX relies on the presence of the PCI clock for $\overline{\text{PME\#}}$ operation. While "0" indicates the no PCI clock is required for the AN983B/BX to generate $\overline{\text{PME\#}}$ .
VER	18:16	ro	<b>Version</b> The value of 010b indicates that the AN983B/BX complies with Revision 1.1 of the PCI Power Management Interface Specification.
NIP	15:8	ro	<b>Next Item Pointer</b> This value is always 0h, indicates that there are no additional items in the Capabilities List.
CAPID	7:0	ro	<b>Capability Identifier</b> This value is always 01h, indicates the link list item as being PCI Power Management Registers.



**Registers and Descriptors Description AN983B/BX Configuration Registers**
**Power Management Register 1**

<b>PMR1_CR49</b>	<b>Offset</b>	<b>Reset Value</b>
<b>Power Management Register 1</b>	<b>C4<sub>H</sub></b>	<b>0000 0000<sub>H</sub></b>

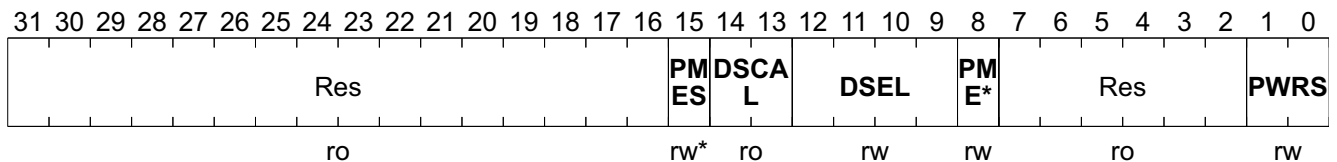

Field	Bits	Type	Description
Res	31:16	ro	<b>Reserved</b>
PMES	15	rw*	<b>PME Status</b> This bit is set when the AN983B/BX would normally assert the $\overline{\text{PME\#}}$ signal for wake-up event, this bit is independent of the state of the PME-En bit. Writing a “1” to this bit will clear it and cause the AN983B/BX to stop asserting a $\overline{\text{PME\#}}$ (if enabled). Writing a “0” has no effect. <i>Note: rw*: Read and Write Clear</i>
DSCAL	14:13	ro	<b>Data Scale</b> Indicates the scaling factor to be used when interpreting the value of the Data register. This field is required for any function that implements the Data register. Otherwise, it’s optional. The AN983B/BX doesn’t support Data register and Data_Scale.
DSEL	12:9	rw	<b>Data Select</b> This four-bit field is used to select which data is to be reported through the Data register and Data_Scale field. This field is required for any function that implements the Data register. The AN983B/BX doesn’t support Data_Select.
PME_En	8	rw	<b>PME En</b> “1” enables the AN983B/BX to assert $\overline{\text{PME\#}}$ . When “0” disables the $\overline{\text{PME\#}}$ assertion. Magic packet default enable: When Csr18 <18> and csr18 <19> are set to 1, than the magic packet wake up event will be default enabled (csr13 <9> be set) it doesn’t matter the PME_En is set or not.
Res	7:2	ro	<b>Reserved</b>
PWRS	1:0	rw	<b>Power State</b> This two-bit field is used both to determine the current power state of the AN983B/BX and to set the AN983B/BX into a new power state. The definition of this field is given below. <i>Note: This field is auto cleared to D0 when power resumed.</i>  00 <sub>B</sub> <b>D0</b> , 01 <sub>B</sub> <b>D1</b> , 10 <sub>B</sub> <b>D2</b> , 11 <sub>B</sub> <b>D3hot</b> ,

rw\*: Read and Write clear

## 9.2 PCI Control/Status Registers

Table 12 Registers Address Space

Module	Base Address	End Address	Note
	0000 0000 <sub>H</sub>	0000 00FC <sub>H</sub>	

Table 13 Registers Overview

Register Short Name	Register Long Name	Offset Address	Page Number
<a href="#">PAR_CSR0</a>	PCI Access Register	00 <sub>H</sub>	<a href="#">53</a>
<a href="#">TDR_CSR1</a>	Transmit Demand Register	08 <sub>H</sub>	<a href="#">54</a>
<a href="#">RDR_CSR2</a>	Receive Demand Register	10 <sub>H</sub>	<a href="#">56</a>
<a href="#">RDB_CSR3</a>	Receive Descriptor Base Address	18 <sub>H</sub>	<a href="#">56</a>
<a href="#">TDB_CSR4</a>	Transmit Descriptor Base Address	20 <sub>H</sub>	<a href="#">57</a>
<a href="#">SR_CSR5</a>	Status Register	28 <sub>H</sub>	<a href="#">57</a>
<a href="#">NAR_CSR6</a>	Network Access Register	30 <sub>H</sub>	<a href="#">61</a>
<a href="#">IER_CSR7</a>	Interrupt Enable Register	38 <sub>H</sub>	<a href="#">62</a>
<a href="#">LPC_CSR8</a>	Lost Packet Counter	40 <sub>H</sub>	<a href="#">64</a>
<a href="#">SPR_CSR9</a>	Serial Port Register	48 <sub>H</sub>	<a href="#">64</a>
<a href="#">TMR_CSR11</a>	General-Purpose Timer	58 <sub>H</sub>	<a href="#">65</a>
<a href="#">WCSR_CSR13</a>	Wake-up Control/Status Register	68 <sub>H</sub>	<a href="#">65</a>
<a href="#">WTMR_CSR15</a>	Watchdog Timer	78 <sub>H</sub>	<a href="#">68</a>
<a href="#">ACSR5_CSR16</a>	Assistant CSR5 (Status Register 2)	80 <sub>H</sub>	<a href="#">69</a>
<a href="#">ACSR7_CSR17</a>	Assistant CSR7 (Interrupt Enable Register 2)	84 <sub>H</sub>	<a href="#">72</a>
<a href="#">CR_CSR18</a>	Command Register	88 <sub>H</sub>	<a href="#">73</a>
<a href="#">PCIC_CSR19</a>	PCI Bus Performance Counter	8C <sub>H</sub>	<a href="#">76</a>
<a href="#">PMCSR_CSR20</a>	Power Management Command and Status	90 <sub>H</sub>	<a href="#">76</a>
<a href="#">WTDP_CSR21</a>	Current Working Transmit Descriptor Pointer	94 <sub>H</sub>	<a href="#">78</a>
<a href="#">WRDP_CSR22</a>	Current Working Receive Descriptor Pointer	98 <sub>H</sub>	<a href="#">78</a>
<a href="#">TXBR_CSR23</a>	Transmit Burst Count/Time-out	9C <sub>H</sub>	<a href="#">79</a>
<a href="#">FROM_CSR24</a>	Flash ROM (also the boot ROM) Port	A0 <sub>H</sub>	<a href="#">79</a>
<a href="#">PAR0_CSR25</a>	Physical Address Register 0	A4 <sub>H</sub>	<a href="#">80</a>
<a href="#">PAR1_CSR26</a>	Physical Address Register 1	A8 <sub>H</sub>	<a href="#">80</a>
<a href="#">MAR0_CSR27</a>	Multicast Address Register 0	AC <sub>H</sub>	<a href="#">80</a>
<a href="#">MAR1_CSR28</a>	Multicast Address Register 1	B0 <sub>H</sub>	<a href="#">82</a>
<a href="#">UAR0_CSR_29</a>	Unicast Address Register 0	B4 <sub>H</sub>	<a href="#">83</a>
<a href="#">UAR1_CSR_30</a>	Unicast Address Register 1	B8 <sub>H</sub>	<a href="#">83</a>
<a href="#">OMR</a>	Operation Mode Register	FC <sub>H</sub>	<a href="#">83</a>

The register is addressed wordwise.

Standard abbreviations:

**Registers and Descriptors Description PCI Control/Status Registers**
**Table 14 Registers Access Types**

Mode	Symbol	Description Hardware (HW)	Description Software (SW)
read/write	rw	Register is used as input for the HW	Register is read and writable by SW
read	r	Register is written by HW (register between input and output -> one cycle delay)	Value written by software is ignored by hardware; that is, software may write any value to this field without affecting hardware behavior (= Target for development.)
write	w		Register is writable by SW
read/write hardware affected	rwh	Register can be modified by HW	Register can be modified by HW, but the priority SW versus HW has to be specified
	rwv		
Read only	ro	Register is set by HW (register between input and output -> one cycle delay)	SW can only read this register
Read virtual	rv	Physically, there is no new register, the input of the signal is connected directly to the address multiplexer.	SW can only read this register
Latch high, self clearing	lhsc	Latch high signal at high level, clear on read	SW can read the register
Latch low, self clearing	llsc	Latch high signal at low-level, clear on read	SW can read the register
Latch high, mask clearing	lhmk	Latch high signal at high level, register cleared with written mask	SW can read the register, with write mask the register can be cleared (1 clears)
Latch low, mask clearing	llmk	Latch high signal at low-level, register cleared on read	SW can read the register, with write mask the register can be cleared (1 clears)
Interrupt high, self clearing	ihsc	Differentiate the input signal (low->high) register cleared on read	SW can read the register
Interrupt low, self clearing	ilsc	Differentiate the input signal (high->low) register cleared on read	SW can read the register
Interrupt high, mask clearing	ihmk	Differentiate the input signal (high->low) register cleared with written mask	SW can read the register, with write mask the register can be cleared
Interrupt low, mask clearing	ilmk	Differentiate the input signal (low->high) register cleared with written mask	SW can read the register, with write mask the register can be cleared
Interrupt enable register	ien	Enables the interrupt source for interrupt generation	SW can read and write this register
latch_on_reset	lor	rw register, value is latched after first clock cycle after reset	Register is read and writable by SW
Read/write self clearing	rwsc	Register is used as input for the hw, the register will be cleared due to a HW mechanism.	Writing to the register generates a strobe signal for the HW (1 pdi clock cycle) Register is read and writable by SW.

**9.2.1 PCI Control/Status Registers Description**



## Registers and Descriptors Description PCI Control/Status Registers

Field	Bits	Type	Description
CAL	15:14	rw*	<b>Cache Alignment, Address Boundary for Data Burst, Set after Reset</b> <i>Note: rw*: Before writing the transmitting and receiving operations should be stopped.</i>  00 <sub>B</sub> , reserved (default) 01 <sub>B</sub> , 8 DW boundary alignment 10 <sub>B</sub> , 16 DW boundary alignment 11 <sub>B</sub> , 32 DW boundary alignment
PBL	13:8	rw*	<b>Programmable Burst Length</b> This value defines the maximum number of DW to be transferred in one DMA transaction. Value: 0 (unlimited), 1, 2, 4, 8, 16 (default), 32 <i>Note: rw*: Before writing the transmitting and receiving operations should be stopped.</i>
BLE	7	rw*	<b>Big or Little Endian Selection</b> <i>Note: rw*: Before writing the transmitting and receiving operations should be stopped.</i>  0 <sub>B</sub> , little endian (e.g. INTEL) 1 <sub>B</sub> , big endian (only for data buffer)
DSL	6:2	rw*	<b>Descriptor Skip Length</b> Defines the gap between two descriptions in the units of DW. <i>Note: rw*: Before writing the transmitting and receiving operations should be stopped.</i>
BAR	1	rw*	<b>Bus Arbitration</b> <i>Note: rw*: Before writing the transmitting and receiving operations should be stopped.</i>  0 <sub>B</sub> , receive higher priority 1 <sub>B</sub> , transmit higher priority
SWR	0	rw*	<b>Software Reset</b> <i>Note: rw*: Before writing the transmitting and receiving operations should be stopped.</i>  1 <sub>B</sub> , reset all internal hardware except configuration registers. This signal will be cleared by AN983B/BX itself after it completed the reset process.

## Transmit Demand Register

TDR_CSR1	Offset	Reset Value
Transmit Demand Register	08 <sub>H</sub>	FFFF FFFF <sub>H</sub>

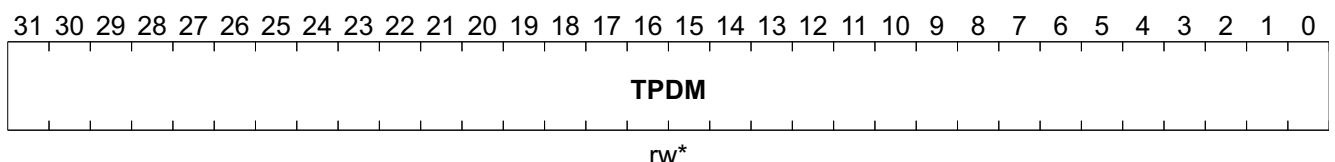

Registers and Descriptors Description PCI Control/Status Registers

Field	Bits	Type	Description
TPDM	31:0	rw*	<p><b>Transmit Poll Demand</b></p> <p>When written any value in suspended state, trigger read-tx-descriptor process and check the own-bit, if own-bit = 1, then start transmit process.</p> <p><i>Note: rw*: Before writing the transmitting process should be in the suspended state.</i></p>

## Registers and Descriptors Description PCI Control/Status Registers

## Receive Demand Register

<b>RDR_CSR2</b>	<b>Offset</b>	<b>Reset Value</b>
Receive Demand Register	10 <sub>H</sub>	FFFF FFFF <sub>H</sub>

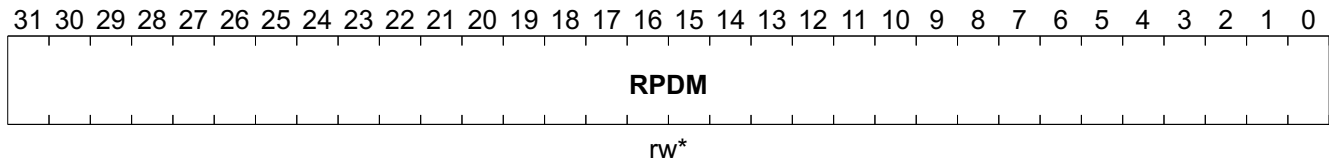

Field	Bits	Type	Description
RPDM	31:0	rw*	<b>Receive Poll Demand</b> When written any value in suspended state, trigger the read-rx-descriptor process and check own-bit, if own-bit = 1, then start move data to buffer from FIFO. <i>Note: rw*: Before writing the receiving process should be in the suspended state.</i>

## Receive Descriptor Base Address

<b>RDB_CSR3</b>	<b>Offset</b>	<b>Reset Value</b>
Receive Descriptor Base Address	18 <sub>H</sub>	xxxx xxxx <sub>H</sub>

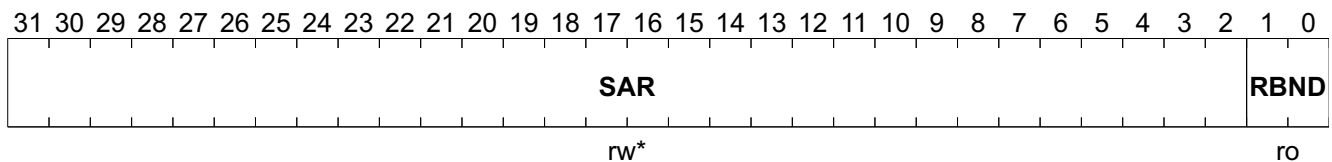

Field	Bits	Type	Description
SAR	31:2	rw*	<b>Start Address of Receive Descriptor</b> <i>Note: rw*: Before writing the receiving process should be stopped.</i>
RBND	1:0	ro	<b>Must be 00, DW Boundary</b>





## Registers and Descriptors Description PCI Control/Status Registers

Field	Bits	Type	Description
TS	22:20	ro	<b>Transmit State</b> Report the current transmission state only, no interrupt will be generated. 000 <sub>B</sub> , stop 001 <sub>B</sub> , read descriptor 010 <sub>B</sub> , transmitting 011 <sub>B</sub> , FIFO fill read the data from memory and put into FIFO 100 <sub>B</sub> , reserved 101 <sub>B</sub> , reserved 110 <sub>B</sub> , suspended, unavailable transmit descriptor or FIFO overflow 111 <sub>B</sub> , write descriptor
RS	19:17	ro	<b>Receive State</b> Report current receive state only, no interrupt will be generated. 000 <sub>B</sub> , stop 001 <sub>B</sub> , read descriptor 010 <sub>B</sub> , check this packet and pre-fetch next descriptor 011 <sub>B</sub> , wait for receiving data 100 <sub>B</sub> , suspended 101 <sub>B</sub> , write descriptor 110 <sub>B</sub> , flush the current FIFO 111 <sub>B</sub> , FIFO drain. move data from receiving FIFO into memory
NISS	16	ro/lh	<b>Normal Interrupt Status Summary</b> It's set if any of below bits of CSR5 asserted. (Combines with bit 16 of ACSR5) bit0, transmit completed interrupt bit2, transmit descriptor unavailable bit6, receive descriptor interrupt <i>Note: lh: High Latching and cleared by writing 1</i>
AISS	15	ro/lh	<b>Abnormal Interrupt Status Summary</b> It's set if any of below bits of CSR5 asserted. (Combines with bit 15 of ACSR5) bit1, transmit process stopped bit3, transmit jabber timer time-out bit5, transmit under-flow bit7, receive descriptor unavailable bit8, receive processor stopped bit9, receive watchdog time-out bit11, general purpose timer time-out bit13, fatal bus error <i>Note: lh: High Latching and cleared by writing 1</i>
Res	14	ro	<b>Reserved</b>
FBE	13	ro/lh	<b>Fatal Bus Error</b> <i>Note: lh: High Latching and cleared by writing 1</i> 1 <sub>B</sub> , while any of parity error master abort, or target abort is occurred (see bits 25~23 of CSR5) AN983B/BX will disable all bus access. The way to recover parity error is by setting software reset.
Res	12	ro	<b>Reserved</b>

## Registers and Descriptors Description PCI Control/Status Registers

Field	Bits	Type	Description
GPTT	11	ro/lh	<b>General Purpose Timer Time-out</b> Base on CSR11 timer register. <i>Note: lh: High Latching and cleared by writing 1</i>
Res	10	ro	<b>Reserved</b>
RWT	9	ro/lh	<b>Receive Watchdog Time-out</b> Based on CSR15 watchdog timer register. <i>Note: lh: High Latching and cleared by writing 1</i>
RPS	8	ro/lh	<b>Receive Process Stopped</b> Receive state = stop <i>Note: lh: High Latching and cleared by writing 1</i>
RDU	7	ro/lh	<b>Receive Descriptor Unavailable</b> <i>Note: lh: High Latching and cleared by writing 1</i>  $1_B$ , while the next receive descriptor can't be applied by AN983B/BX. The receive process is suspended in this situation. To restart the receive process the ownership bit of next receive descriptor should be set to AN983B/BX and a receive poll demand command should be issued (or a new recognized frame is received, if the receive poll demand is not issued).
RCI	6	ro/lh	<b>Receive Completed Interrupt</b> <i>Note: lh: High Latching and cleared by writing 1</i>  $1_B$ , while a frame reception is completed
TUF	5	ro/lh	<b>Transmit Under-Flow</b> <i>Note: lh: High Latching and cleared by writing 1</i>  $1_B$ , while the transmit FIFO had an under-flow condition happened during transmitting. The transmit process will enter the suspended state and report the under-flow error on bit1 of TDES0
Res	4	ro	<b>Reserved</b>
TJT	3	ro/lh	<b>Transmit Jabber Timer Time-out</b> <i>Note: lh: High Latching and cleared by writing 1</i>  $1_B$ , while the transmit jabber timer expired. The transmit processor will enter the stop state and the transmit jabber time-out flag of bit 14 of TDES0 will be asserted
TDU	2	ro/lh	<b>Transmit Descriptor Unavailable</b> <i>Note: lh: High Latching and cleared by writing 1</i>  $1_B$ , while the next transmit descriptor can't be applied by AN983B/BX. The transmission process is suspended in this situation. To restart the transmission process the ownership bit of next transmit descriptor should be set to AN983B/BX and if the transmit automatic polling is not enabled then a transmit poll demand command should be issued.
TPS	1	ro/lh	<b>Transmit Process Stopped</b> <i>Note: lh: High Latching and cleared by writing 1</i>  $1_B$ , while transmit state = stop

Registers and Descriptors Description PCI Control/Status Registers

Field	Bits	Type	Description
TCI	0	ro/lh	<p><b>Transmit Completed Interrupt</b></p> <p><i>Note: lh: High Latching and cleared by writing 1</i></p> <p>1<sub>B</sub> , means a frame transmission is completed while bit 31 of TDES1 is asserted in the first transmit descriptor of the frame</p>

Registers and Descriptors Description PCI Control/Status Registers

Network Access Register

**NAR\_CSR6** **Offset** **Reset Value**  
**Network Access Register** **30<sub>H</sub>** **0008 0040<sub>H</sub>**

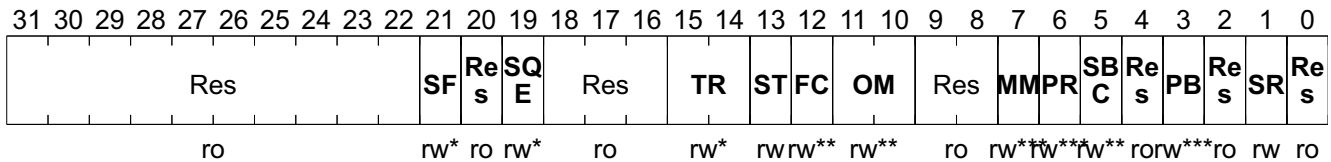

Field	Bits	Type	Description
Res	31:22	ro	<b>Reserved</b>
SF	21	rw*	<b>Store and Forward for Transmit</b> <i>Note: w* = only write when the transmit processor stoppes.</i> 0 <sub>B</sub> , disable 1 <sub>B</sub> , enable ignore the transmit threshold setting
Res	20	ro	<b>Reserved</b>
SQE	19	rw*	<b>SQE Disable</b> <i>Note: w* = only write when the transmit processor stoppes.</i> 0 <sub>B</sub> , enable SQE function for 10BASE-T operation. The AN983B/BX provides SQE test function for 10BASE-T half duplex operation 1 <sub>B</sub> , disable SQE function
Res	18:16	ro	<b>Reserved</b>
TR	15:14	rw*	<b>Transmit Threshold Control</b> <i>Note: w* = only write when the transmit processor stoppes.</i> 00 <sub>B</sub> , 128-byte (100 Mbit/s) 72-byte (10 Mbit/s) 01 <sub>B</sub> , 256-byte (100 Mbit/s) 96-byte (10 Mbit/s) 10 <sub>B</sub> , 512-byte (100 Mbit/s) 128-byte (10 Mbit/s) 00 <sub>B</sub> , 1024-byte (100 Mbit/s) 160 -byte (10 Mbit/s)
ST	13	rw	<b>Stop Transmit</b> 0 <sub>B</sub> , stop (default) 1 <sub>B</sub> , start
FC	12	rw**	<b>Force Collision Mode</b> <i>Note: w** = only write when the transmit and receive processor both stop.</i> 0 <sub>B</sub> , disable 1 <sub>B</sub> , generate collision when transmit (for test in loop-back mode)
OM	11:10	rw**	<b>Operating Mode</b> <i>Note: w** = only write when the transmit and receive processor both stop.</i> 00 <sub>B</sub> , normal 01 <sub>B</sub> , MAC loop-back 10 <sub>B</sub> , reserved 11 <sub>B</sub> , reserved

Registers and Descriptors Description PCI Control/Status Registers

Field	Bits	Type	Description
Res	9:8	ro	<b>Reserved</b>
MM	7	rw***	<b>Multicast Mode</b> <i>Note: w*** = only write when the receive processor stoppes.</i> 1 <sub>B</sub> , receive all multicast packets
PR	6	rw***	<b>Promiscuous Mode</b> <i>Note: w*** = only write when the receive processor stoppes.</i> 0 <sub>B</sub> , receive only the right destination address packets 1 <sub>B</sub> , receive any good packet
SBC	5	rw**	<b>Stop Back-off Counter</b> <i>Note: w** = only write when the transmit and receive processor both stop.</i> 0 <sub>B</sub> , back-off counter is not effected by carrier 1 <sub>B</sub> , back-off counter stop when carrier is active and resume when carrier drop.
Res	4	ro	<b>Reserved</b>
PB	3	rw***	<b>Pass Bad Packet</b> <i>Note: w*** = only write when the receive processor stoppes.</i> 0 <sub>B</sub> , filters all bad packets 1 <sub>B</sub> , receives any packets if pass address filter, including small packets, CRC error, truncated packets... For receiving all bad packets, the bit 6 of CSR6 should be set to 1.
Res	2	ro	<b>Reserved</b>
SR	1	rw	<b>Start/Stop Receive</b> 0 <sub>B</sub> , receive processor will enter stop state after the current reception frame has completed. This value is effective only when the receive processor is in the running or suspending state. Notice: In "Stop Receive" state the PAUSE packet and Remote Wake Up packet won't be affected and can be received if the corresponding function is enabled. 1 <sub>B</sub> , receive processor will enter running state
Res	0	ro	<b>Reserved</b>

**Interrupt Enable Register**

**IER\_CSR7** **Offset**  
**Interrupt Enable Register** **38<sub>H</sub>** **Reset Value**  
**0000 0000<sub>H</sub>**

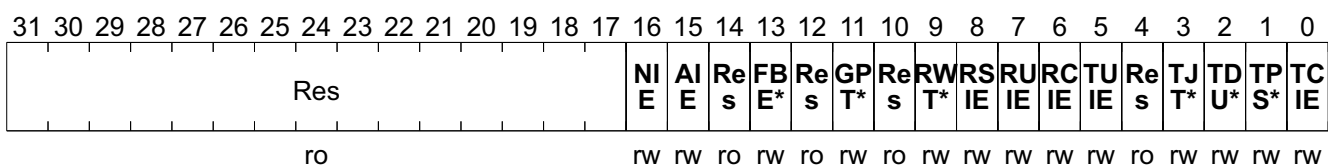

## Registers and Descriptors Description PCI Control/Status Registers

Field	Bits	Type	Description
Res	31:17	ro	<b>Reserved</b>
NIE	16	rw	<b>Normal Interrupt Enable</b> 1 <sub>B</sub> , enable all the normal interrupt bits (see bit16 of CSR5)
AIE	15	rw	<b>Abnormal Interrupt Enable</b> 1 <sub>B</sub> , enable all the abnormal interrupt bits (see bit15 of CSR5)
Res	14	ro	<b>Reserved</b>
FBEIE	13	rw	<b>Fatal Bus Error Interrupt Enable</b> 1 <sub>B</sub> , combine this bit and bit 15 of CSR7 to enable fatal bus error interrupt
Res	12	ro	<b>Reserved</b>
GPTIE	11	rw	<b>General Purpose Timer Interrupt Enable</b> 1 <sub>B</sub> , combine this bit and bit 15 of CSR7 to enable general-purpose timer expired interrupt
Res	10	ro	<b>Reserved</b>
RWTIE	9	rw	<b>Receive Watchdog Time-out Interrupt Enable</b> 1 <sub>B</sub> , combine this bit and bit 15 of CSR7 to enable receive watchdog time-out interrupt
RSIE	8	rw	<b>Receive Stopped Interrupt Enable</b> 1 <sub>B</sub> , combine this bit and bit 15 of CSR7 to enable receive stopped interrupt
RUIE	7	rw	<b>Receive Descriptor Unavailable Interrupt Enable</b> 1 <sub>B</sub> , combine this bit and bit 15 of CSR7 to enable receive descriptor unavailable interrupt
RCIE	6	rw	<b>Receive Completed Interrupt Enable</b> 1 <sub>B</sub> , combine this bit and bit 16 of CSR7 to enable receive completed interrupt
TUIE	5	rw	<b>Transmit Under-flow Interrupt Enable</b> 1 <sub>B</sub> , combine this bit and bit 15 of CSR7 to enable transmit under-flow interrupt
Res	4	ro	<b>Reserved</b>
TJTIE	3	rw	<b>Transmit Jabber Timer Time-out Interrupt Enable</b> 1 <sub>B</sub> , combine this bit and bit 15 of CSR7 to enable transmit jabber timer time-out interrupt
TDUIE	2	rw	<b>Transmit Descriptor Unavailable Interrupt Enable</b> 1 <sub>B</sub> , combine this bit and bit 16 of CSR7 to enable transmit descriptor unavailable interrupt
TPSIE	1	rw	<b>Transmit Processor Stopped Interrupt Enable</b> 1 <sub>B</sub> , combine this bit and bit 15 of CSR7 to enable transmit processor stopped interrupt
TCIE	0	rw	<b>Transmit Completed Interrupt Enable</b> 1 <sub>B</sub> , combine this bit and bit 16 of CSR7 to enable transmit completed interrupt.

Registers and Descriptors Description PCI Control/Status Registers

Lost Packet Counter

<b>LPC_CSR8</b>	<b>Offset</b>	<b>Reset Value</b>
<b>Lost Packet Counter</b>	<b>40<sub>H</sub></b>	<b>0000 0000<sub>H</sub></b>

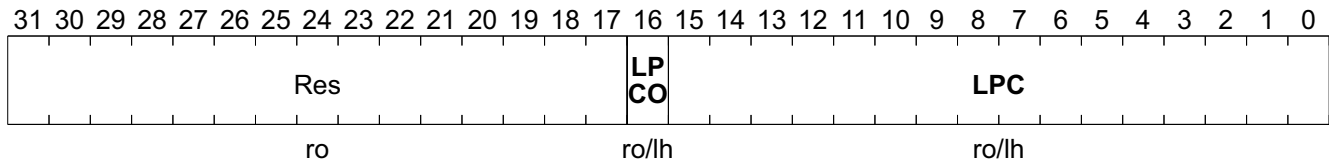

Field	Bits	Type	Description
Res	31:17	ro	<b>Reserved</b>
LPCO	16	ro/lh	<b>Lost Packet Counter Overflow</b> <i>Note: LH = High Latching and cleared by writing 1</i> 1 <sub>B</sub> , while lost packet counter overflowed. Cleared after read
LPC	15:0	ro/lh	<b>Lost Packet Counter</b> Increment the counter while packet discarded since there was no host receives descriptors available. Cleared after read. <i>Note: LH = High Latching and cleared by writing 1</i>

Serial Port Register

<b>SPR_CSR9</b>	<b>Offset</b>	<b>Reset Value</b>
<b>Serial Port Register</b>	<b>48<sub>H</sub></b>	<b>0004 000E<sub>H</sub></b>

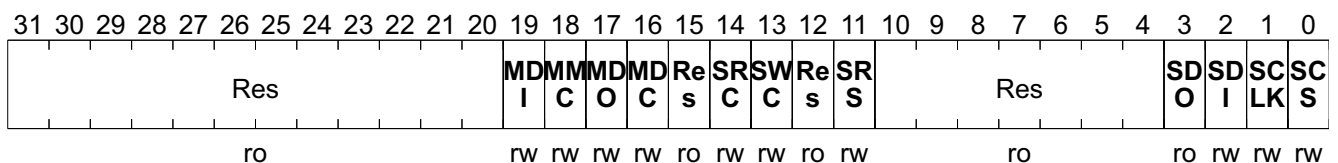

Field	Bits	Type	Description
Res	31:20	ro	<b>Reserved</b>
MDI	19	rw	<b>MII Management Data Input</b> Specified read data from the external PHY
MMC	18	rw	<b>MII Management Control</b> 0 <sub>B</sub> , Write operation to the external PHY 1 <sub>B</sub> , Read operation from the external PHY
MDO	17	rw	<b>MII Management Data Output</b> Specified Write Data to the external PHY



**Registers and Descriptors Description PCI Control/Status Registers**

Field	Bits	Type	Description
MDC	16	rw	<b>MII Management Clock</b> 1 <sub>B</sub> , MII Management Clock is a output reference clock to the external PHY
Res	15	ro	<b>Reserved</b>
SRC	14	rw	<b>Serial EEPROM Read Control</b> Set together with CSR9 bit11 to enable read operation from EEPROM
SWC	13	rw	<b>Serial EEPROM Write Control</b> Set together with CSR9 bit11 to enable write operation to EEPROM
Res	12	ro	<b>Reserved</b>
SRS	11	rw	<b>Serial EEPROM Select</b> Set together with CSR9 bit14 or 13 to enable EEPROM access
Res	10:4	ro	<b>Reserved</b>
SDO	3	ro	<b>Serial EEPROM Data Out</b> This bit serially shifts data from the EEPROM to the AN983B/BX.
SDI	2	rw	<b>Serial EEPROM Data In</b> This bit serially shifts data from the AN983B/BX to the EEPROM.
SCLK	1	rw	<b>Serial EEPROM Clock</b> High/Low this bit to provide the clock signal for EEPROM.
SCS	0	rw	<b>Serial EEPROM Chip Select</b> 1 <sub>B</sub> , selects the serial EEPROM chip

**General-Purpose Timer**

<b>TMR_CSR11</b>	<b>Offset</b>	<b>Reset Value</b>
<b>General-Purpose Timer</b>	<b>58<sub>H</sub></b>	<b>0000 0000<sub>H</sub></b>

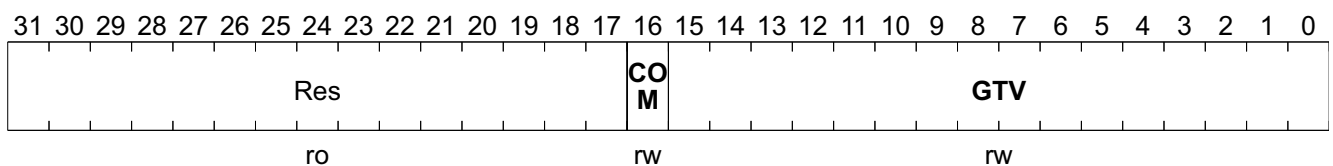

Field	Bits	Type	Description
Res	31:17	ro	<b>Reserved</b>
COM	16	rw	<b>Continuous Operation Mode</b> 1 <sub>B</sub> , sets the general-purpose timer in continuous operating mode
GTV	15:0	rw	<b>General-Purpose Timer Value</b> Sets the counter value. This is a countdown counter with the cycle time of 204 $\mu$ s.

**Wake-up Control/Status Register**

**Registers and Descriptors Description PCI Control/Status Registers**

**WCSR\_CSR13** **Offset**  
**Wake-up Control/Status Register** **68<sub>H</sub>** **Reset Value**  
**??<sub>H</sub>**

31	30	29	28	27	26	25	24	23	22	21	20	19	18	17	16	15	14	13	12	11	10	9	8	7	6	5	4	3	2	1	0	
Res	CR	WP	WP	WP	WP	WP					Res			Li	Li				Res			WF	MP	LS						WF	MP	LS
CT	1E	2E	3E	4E	5E									n*	n*							RE	RE	CE						R	R	C
ro	rw	rw	rw	rw	rw	rw					ro			rw	rw				ro			rw	rw	rw					ro	rw	1c	1c

Field	Bits	Type	Description
Res	31	ro	<b>Reserved</b>
CRCT	30	rw	<b>CRC-16 Type</b> 0 <sub>B</sub> , Initial contents = 0000h 1 <sub>B</sub> , Initial contents = FFFFh
WP1E	29	rw	<b>Wake-up Pattern n Matched Enable</b> n = 1 to 5
WP2E	28	rw	
WP3E	27	rw	
WP4E	26	rw	
WP5E	25	rw	
Res	24:18	ro	<b>Reserved</b>
LinkOFF	17	rw	<b>Link Off Detect Enable</b> The AN983B/BX will set the LSC bit of CSR13 after it has detected that link status is from ON to OFF.
LinkON	16	rw	<b>Link On Detect Enable</b> The AN983B/BX will set the LSC bit of CSR13 after it has detected that link status is from OFF to ON.
Res	15:11	ro	<b>Reserved</b>
WFRE	10	rw	<b>Wake-up Frame Received Enable</b> The AN983B/BX will include the "Wake-up Frame Received" event into wake-up events. If this bit is set, AN983B/BX will assert PMES bit of PMR1 after AN983B/BX has received a matched wake-up frame.
MPRE	9	rw	<b>Magic Packet Received Enable</b> The AN983B/BX will include the "Magic Packet Received" event into wake-up events. If this bit is set, AN983B/BX will assert PMES bit of PMR1 after AN983B/BX has received a Magic packet.
LSCE	8	rw	<b>Link Status Changed Enable</b> The AN983B/BX will include the "Link Status Changed" event into wake-up events. If this bit is set, AN983B/BX will assert PMES bit of PMR1 after AN983B/BX has detected a link status changed event.
Res	7:3	ro	<b>Reserved</b>
WFR	2	rw1c	<b>Wake-up Frame Received</b> <i>Note: rw1c: Read only and Write one cleared.</i> 1 <sub>B</sub> , indicates AN983B/BX has received a wake-up frame. It is cleared by writing 1 or upon power-up reset. It is not affected by a hardware or software reset

## Registers and Descriptors Description PCI Control/Status Registers

Field	Bits	Type	Description
MPR	1	rw1c	<b>Magic Packet Received</b> <i>Note: rw1c: Read only and Write one cleared.</i> 1 <sub>B</sub> , indicates AN983B/BX has received a magic packet. It is cleared by writing 1 or upon power-up reset. It is not affected by a hardware or software reset
LSC	0	rw1c	<b>Link Status Changed</b> <i>Note: rw1c: Read only and Write one cleared.</i> 1 <sub>B</sub> , indicates AN983B/BX has detected a link status change event. It is cleared by writing 1 or upon power-up reset. It is not affected by a hardware or software reset

**CSR14, WPDR – Wake-up Pattern Data Register**

All six wake-up patterns filtering information are programmed through WPDR register. The filtering information is as follows:

Offset	31-24	23-16	15-8	7-0
0000h	Wake-up pattern 1 mask bits 31:0			
0004h	Wake-up pattern 1 mask bits 63:32			
0008h	Wake-up pattern 1 mask bits 95:64			
000ch	Wake-up pattern 1 mask bits 127:96			
0010h	CRC16 of pattern 1		Reserved	Wake-up pattern 1 offset
0014h	Wake-up pattern 2 mask bits 31:0			
0018h	Wake-up pattern 2 mask bits 63:32			
001ch	Wake-up pattern 2 mask bits 95:64			
0020h	Wake-up pattern 2 mask bits 127:96			
0024h	CRC16 of pattern 2		Reserved	Wake-up pattern 2 offset
0028h	Wake-up pattern 3 mask bits 31:0			
002ch	Wake-up pattern 3 mask bits 63:32			
0030h	Wake-up pattern 3 mask bits 95:64			
0034h	Wake-up pattern 3 mask bits 127:96			
0038h	CRC16 of pattern 3		Reserved	Wake-up pattern 3 offset
003ch	Wake-up pattern 4 mask bits 31:0			
0040h	Wake-up pattern 4 mask bits 63:32			
0044h	Wake-up pattern 4 mask bits 95:64			
0048h	Wake-up pattern 4 mask bits 127:96			
004ch	CRC16 of pattern 4		Reserved	Wake-up pattern 4 offset
0050h	Wake-up pattern 5 mask bits 31:0			
0054h	Wake-up pattern 5 mask bits 63:32			
0058h	Wake-up pattern 5 mask bits 95:64			
005ch	Wake-up pattern 5 mask bits 127:96			
0060h	CRC16 of pattern 5		Reserved	Wake-up pattern 5 offset

1. Offset value is from 0-255 (8-bit width).

Registers and Descriptors Description PCI Control/Status Registers

- To load the whole wake-up frame-filtering information, consecutive 25 long words write operation to CSR14 should be done.

**Watchdog Timer**

**WTMR\_CSR15** **Offset** **Reset Value**  
**Watchdog Timer** **78<sub>H</sub>** **0000 0000<sub>H</sub>**

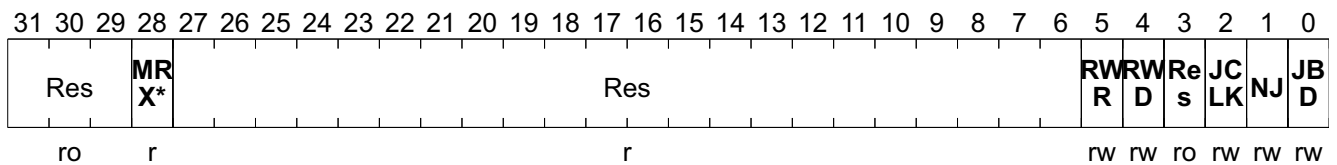

Field	Bits	Type	Description
Res	31:29	ro	<b>Reserved</b>
MRXCK	28	r	<b>MII Rx Clock Reverse</b> 0 <sub>B</sub> , NOT reverse 1 <sub>B</sub> , reverse (for NS HomePHY 1M only)
Res	27:6	r	<b>Reserved</b>
RWR	5	rw	<b>Receive Watchdog Release</b> The time of release watchdog timer from last carrier deserted. 0 <sub>B</sub> , 24 bit-time 1 <sub>B</sub> , 48 bit-time
RWD	4	rw	<b>Receive Watchdog Disable</b> 0 <sub>B</sub> , If the receiving packet's length is longer than 2560 bytes the watchdog timer will be expired 1 <sub>B</sub> , disable the receive watchdog
Res	3	ro	<b>Reserved</b>
JCLK	2	rw	<b>Jabber Clock</b> 0 <sub>B</sub> , cut off transmission after 2.6 ms (100 Mbit/s) or 26 ms (10 Mbit/s) 1 <sub>B</sub> , cut off transmission after 2560 byte-time
NJ	1	rw	<b>Non-Jabber</b> 0 <sub>B</sub> , if jabber expired re-enable transmit function after 42 ms (100 Mbit/s) or 420 ms (10 Mbit/s) 1 <sub>B</sub> , immediately re-enable the transmit function after jabber expired
JBD	0	rw	<b>Jabber Disable</b> 1 <sub>B</sub> , disable transmit jabber function



**Registers and Descriptors Description PCI Control/Status Registers**

Field	Bits	Type	Description
FBE	13	ro/lh	<b>Fatal Bus Error</b> <i>Note: LH = High Latching and cleared by writing 1</i> $1_B$ , while any of parity error master abort, or target abort is occurred (see bits 25~23 of CSR5) AN983B/BX will disable all bus access. The way to recover parity error is by setting software reset.
Res	12	ro	<b>Reserved</b>
GPTT	11	ro/lh	<b>General Purpose Timer Time-out</b> Base on CSR11 timer register. <i>Note: LH = High Latching and cleared by writing 1</i>
Res	10	ro	<b>Reserved</b>
RWT	9	ro/lh	<b>Receive Watchdog Time-out</b> Based on CSR15 watchdog timer register. <i>Note: LH = High Latching and cleared by writing 1</i>
RPS	8	ro/lh	<b>Receive Process Stopped</b> Receive state = stop <i>Note: LH = High Latching and cleared by writing 1</i>
RDU	7	ro/lh	<b>Receive Descriptor Unavailable</b> <i>Note: LH = High Latching and cleared by writing 1</i> $1_B$ , while the next receive descriptor can't be applied by AN983B/BX. Receive process is suspended in this situation. To restart the receive process the ownership bit of the next receive descriptor should be set to AN983B/BX and a receive poll demand command should be issued (or a new recognized frame is received, if the receive poll demand is not issued).
RCI	6	ro/lh	<b>Receive Completed Interrupt</b> <i>Note: LH = High Latching and cleared by writing 1</i> $1_B$ , while a frame reception is completed
TUF	5	ro/lh	<b>Transmit Under-Flow</b> <i>Note: LH = High Latching and cleared by writing 1</i> $1_B$ , while the transmitting FIFO had an under-flow condition. It happened during transmitting. The transmit process will enter the suspended state and report the under-flow error on bit1 of TDES0
Res	4	ro	<b>Reserved</b>
TJT	3	ro/lh	<b>Transmit Jabber Timer Time-out</b> <i>Note: LH = High Latching and cleared by writing 1</i> $1_B$ , while the transmit jabber timer expired. The transmit processor will enter the stop state and the transmit jabber time-out flag of bit 14 of TDES0 will be asserted

**Registers and Descriptors Description PCI Control/Status Registers**

<b>Field</b>	<b>Bits</b>	<b>Type</b>	<b>Description</b>
TDU	2	ro/lh	<p><b>Transmit Descriptor Unavailable</b></p> <p><i>Note: LH = High Latching and cleared by writing 1</i></p> <p>1<sub>B</sub> , while the next transmit descriptor can't be applied by AN983B/BX. The transmission process is suspended in this situation. To restart the transmission process the ownership bit of next transmit descriptor should be set to AN983B/BX and if the transmit automatic polling is not enabled then a transmit poll demand command should be issued.</p>
TPS	1	ro/lh	<p><b>Transmit Process Stopped</b></p> <p><i>Note: LH = High Latching and cleared by writing 1</i></p> <p>1<sub>B</sub> , while transmit state = stop</p>
TCI	0	ro/lh	<p><b>Transmit Completed Interrupt</b></p> <p><i>Note: LH = High Latching and cleared by writing 1</i></p> <p>1<sub>B</sub> , means a frame transmission is completed while bit 31 of TDES1 is asserted in the first transmit descriptor of the frame</p>

Bit14 to 0 are the same as the status register of CSR5. You can access those status bits through either CSR5 or CSR16.





**Registers and Descriptors Description PCI Control/Status Registers**

Field	Bits	Type	Description
RCIE	6	rw	<b>Receive Completed Interrupt Enable</b> 1 <sub>B</sub> , combine this bit and bit 16 of CSR7 to enable receive completed interrupt
TUIE	5	rw	<b>Transmit Under-flow Interrupt Enable</b> 1 <sub>B</sub> , combine this bit and bit 15 of CSR7 to enable transmit under-flow interrupt
Res	4	ro	<b>Reserved</b>
TJTIE	3	rw	<b>Transmit Jabber Timer Time-out Interrupt Enable</b> 1 <sub>B</sub> , combine this bit and bit 15 of CSR7 to enable transmit jabber timer time-out interrupt
TDUIE	2	rw	<b>Transmit Descriptor Unavailable Interrupt Enable</b> 1 <sub>B</sub> , combine this bit and bit 16 of CSR7 to enable transmit descriptor unavailable interrupt
TPSIE	1	rw	<b>Transmit Processor Stopped Interrupt Enable</b> 1 <sub>B</sub> , combine this bit and bit 15 of CSR7 to enable transmit processor stopped interrupt
TCIE	0	rw	<b>Transmit Completed Interrupt Enable</b> 1 <sub>B</sub> , combine this bit and bit 16 of CSR7 to enable transmit completed interrupt.

**Bit14 to 0 are the same as the interrupt enable register of CSR7. You can access those interrupt enable bits through either CSR7 or CSR16**

**Command Register**

Bit 31 to Bit 16

Automatically recall from EEPROM

<b>CR_CSR18</b>	<b>Offset</b>	<b>Reset Value</b>
<b>Command Register</b>	<b>88<sub>H</sub></b>	<b>A04C 0004<sub>H</sub></b>

31	30	29	28	27	26	25	24	23	22	21	20	19	18	17	16	15	14	13	12	11	10	9	8	7	6	5	4	3	2	1	0
D3CS	AUXCL	ATS	PPES	PCIP*	PS	4L	RFS	CRD	PM	APL	WMS	Res						D3A	RWP	PAU*	ARTE	DRT	SINT	ATUR							
rw	ro	rw	rw	rw	rw	rw	rw	rw	ro	rw	rw	ro						rw	rw	rw	rw	rw	rw	rw							

Field	Bits	Type	Description
D3CS	31	rw	<b>D3cold Support, Mapped to CR48&lt;31&gt;</b>
AUXCL	30:28	ro	<b>Aux Current</b> These three bits report the maximum 3.3 Vaux current requirements for AN983B/BX. If bit 31 of PMR0 is '1', the default value is 0101b, means AN983B/BX need 100 mA to support remote wake-up in D3cold power state.

## Registers and Descriptors Description PCI Control/Status Registers

Field	Bits	Type	Description
ATS	27	rw	<b>Actively Type Select</b> PMEP, This bit is only active when PMEP enable CSR18 bit 26 0 <sub>B</sub> , create a positive 50 ms pulse 1 <sub>B</sub> , create a negative 50 ms pulse
PPE	26	rw	<b>PMEP Pin Enable</b> 0 <sub>B</sub> , disable (this pin will be input, to compatible with AN983 circuit) 1 <sub>B</sub> , enable
PCI_R	25	rw	<b>PCI_Reset</b> PWRS_clr 1 <sub>B</sub> , rising will automatically reset CR49/ PWRS[1:0] to 00h
PS	24	rw	<b>Pmes_Sticky</b> 0 <sub>B</sub> , pmez auto de-asserted: While pmez signal is asserted by wake up event it will be de-asserted by power up automatically 1 <sub>B</sub> , pmez sticky: While pmez signal is asserted by wake up event it cannot be auto de-asserted. The software should clear CR49<15> PMES bit to de-assert the pmez signal.
4_3L	23	rw	<b>4_3LED</b> If this bit is reset, 3 LED mode is selected, the LEDs definition is: 100/10 speed Link/Activity Full Duplex/Collision If this bit is set, 4 LED mode is selected, the LEDs definition is: 100 Link 10 Link Activity Full Duplex/Collision
RFS	22:21	rw	<b>Receive FIFO Size Control</b> 00 <sub>B</sub> , reserved 01 <sub>B</sub> , reserved 10 <sub>B</sub> , 2K 11 <sub>B</sub> , 1K
CRD	20	rw	<b>Clock Run (clk-run pin) Disable</b> 1 <sub>B</sub> , disables the function of clock run supports to PCI
PM	19	ro	<b>Power Management</b> Enables the AN983B/BX whether to activate the Power Management abilities. When this bit is set into "0" the AN983B/BX will set the Cap_Ptr register to zero, indicating no PCI compliant power management capabilities. The value of this bit will be mapped to NC-bit 20 of CR1. In PCI Power Management mode, the Wake-up events include "Wake-up Frame Received", "Magic Packet Received" and "Link Status Changed" depends on the CSR13 settings.
APM	18	rw	<b>APM Mode</b> This bit is effective when PM (csr18 [19]) = 1. 0 <sub>B</sub> , Magic Packet wake-up event default disable 1 <sub>B</sub> , Magic Packet wake-up event default enable
LWS	17	rw	Should be 0
Res	16:8	ro	<b>Reserved</b>

## Registers and Descriptors Description PCI Control/Status Registers

Field	Bits	Type	Description
D3A	7	rw	<b>D3_APM</b> D3_cold APM_mode_en for PC99 Certification It doesn't matter the status of PEM_EN, the pmez signal can be asserted by programming this bit. 0 <sub>B</sub> , de-assert pmez signal 1 <sub>B</sub> , Assert pmez signal
RWP	6	rw	<b>Reset Wake-up Pattern Data Register Pointer</b> 0 <sub>B</sub> , Normal 1 <sub>B</sub> , Reset
PAUSE	5	rw	<b>PAUSE Function Control</b> To disable or enable the PAUSE function for flow control. The default value of PAUSE is decided by the result of Auto-Negotiation. Driver can force to enable or disable it after the Auto-Negotiation is completed. 0 <sub>B</sub> , PAUSE function is disabled 1 <sub>B</sub> , PAUSE function is enabled
RTE	4	rw	<b>Receive Threshold Enable</b> 0 <sub>B</sub> , disable the receive FIFO threshold selection in bit 3~2 of this register, the receive threshold is set to 64-byte. 1 <sub>B</sub> , the receive FIFO threshold is enabled
DRT	3:2	rw	<b>Drain Receive Threshold</b> 00 <sub>B</sub> , 32 bytes (8 DW) 01 <sub>B</sub> , 64 bytes (16 DW) 10 <sub>B</sub> , store-and -forward 11 <sub>B</sub> , reserved
SINT	1	rw	<b>Software Interrupt</b>
ATUR	0	rw	<b>Automatically Transmit-underrun Recovery Enable</b> 1 <sub>B</sub> , enable automatically transmit-underrun recovery

Registers and Descriptors Description PCI Control/Status Registers

PCI Bus Performance Counter

**PCIC\_CSR19** **Offset** **Reset Value**  
**PCI Bus Performance Counter** **8C<sub>H</sub>** **0000 0000<sub>H</sub>**

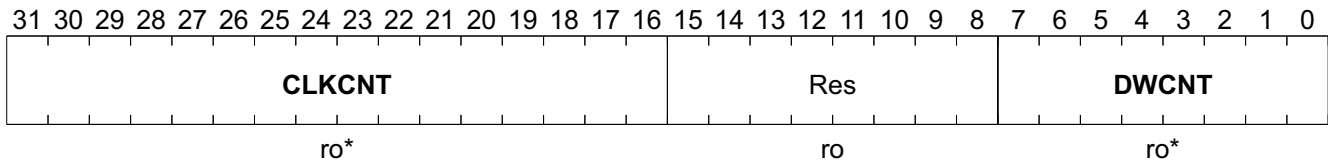

Field	Bits	Type	Description
CLKCNT	31:16	ro*	<b>Clock Count</b> The number of PCI clock from read request asserted to access completed. This PCI clock number is accumulated all the read command cycles from last CSR19 read to current CSR19 read. <i>Note: ro*: Read only and cleared by reading</i>
Res	15:8	ro	<b>Reserved</b>
DWCNT	7:0	ro*	<b>Double Word Count</b> The number of double word accessed by the last bus master. This double word number is accumulated in all the bus master data transactions from last CSR19 read to current CSR19 read. <i>Note: ro*: Read only and cleared by reading</i>

**Power Management Command and Status**

(The same register value mapping to CR49-PMR1)

**PMCSR\_CSR20** **Offset** **Reset Value**  
**Power Management Command and Status** **90<sub>H</sub>** **0000 0000<sub>H</sub>**

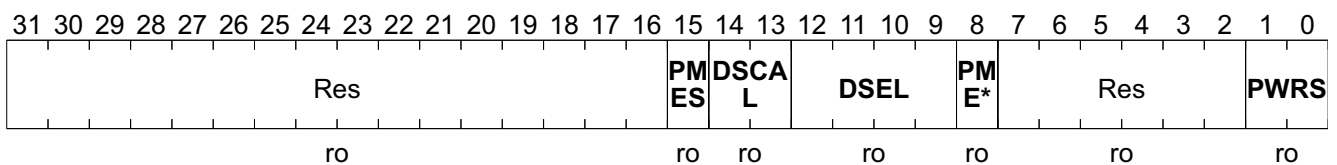

Field	Bits	Type	Description
Res	31:16	ro	<b>Reserved</b>
PMES	15	ro	<b>PME_Status</b> This bit is set when the AN983B/BX would normally assert the $\overline{\text{PME\#}}$ signal for wake-up event, this bit is independent of the state of the PME-En bit. Writing a "1" to this bit will clear it and cause the AN983B/BX to stop asserting a $\overline{\text{PME\#}}$ (if enabled). Writing a "0" has no effect. Since the AN983B/BX doesn't support $\overline{\text{PME\#}}$ from D3cold, this bit is defaulted to "0".

## Registers and Descriptors Description PCI Control/Status Registers

Field	Bits	Type	Description
DSCAL	14:13	ro	<b>Data_Scale</b> Indicates the scaling factor to be used when interpreting the value of the Data register. This field is required for any function that implements the Data register. Otherwise, it is optional. The AN983B/BX doesn't support Data register and Data_Scale.
DSEL	12:9	ro	<b>Data_Select</b> This four bit field is used to select which data is to be reported through the Data register and Data_Scale field. This field is required for any function that implements the Data register. The AN983B/BX doesn't support Data_Select.
PME_En	8	ro	<b>PME_En</b> "1" enables the AN983B/BX to assert $\overline{\text{PME\#}}$ . When "0" disables the $\overline{\text{PME\#}}$ assertion. This bit defaults to "0" if the function does not support $\overline{\text{PME\#}}$ generation from D3cold.
Res	7:2	ro	<b>Reserved</b>
PWRS	1:0	ro	<b>PowerState</b> This two bit field is used both to determine the current power state of the AN983B/BX and to set the AN983B/BX into a new power state. The definition of this field is given below. 00b - D0 01b - D1 10b - D2 11b - D3hot If software attempts to write an unsupported, optional state to this field, the write operation must be complete normally on the bus, however the data is discarded a no state change occurs.

## Registers and Descriptors Description PCI Control/Status Registers

## Current Working Transmit Descriptor Pointer

WTDP_CSR21	Offset	Reset Value
Current Working Transmit Descriptor Pointer	94 <sub>H</sub>	xxxx xxxx <sub>H</sub>

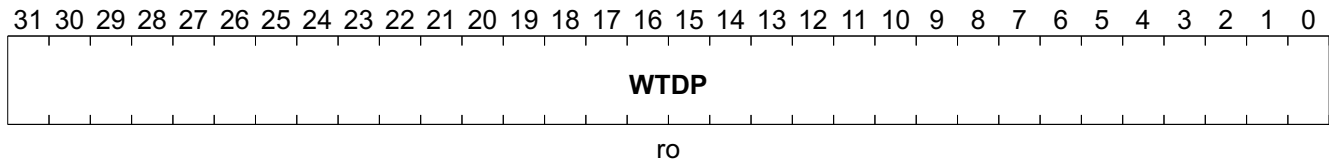

Field	Bits	Type	Description
WTDP	31:0	ro	<b>Working Transmit Descriptor Pointer</b> The current working transmit descriptor pointer for driver's double-checking or other special purpose.

## Current Working Receive Descriptor Pointer

WRDP_CSR22	Offset	Reset Value
Current Working Receive Descriptor Pointer	98 <sub>H</sub>	xxxx xxxx <sub>H</sub>

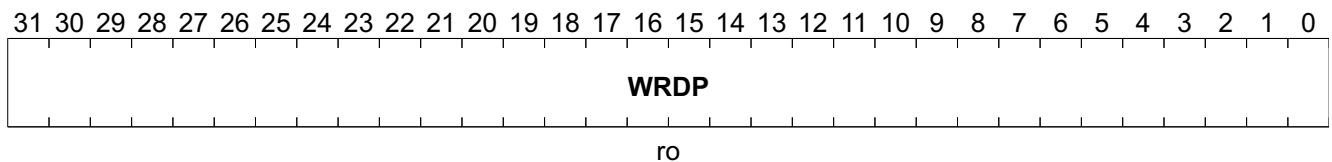

Field	Bits	Type	Description
WRDP	31:0	ro	<b>Working Receive Descriptor Pointer</b> The current working receive descriptor pointer for driver's double-checking or other special purpose.

## Registers and Descriptors Description PCI Control/Status Registers

## Transmit Burst Count/Time-out

**TXBR\_CSR23** **Offset**  
**Transmit Burst Count/Time-out** **9C<sub>H</sub>** **Reset Value**  
**0000 0000<sub>H</sub>**

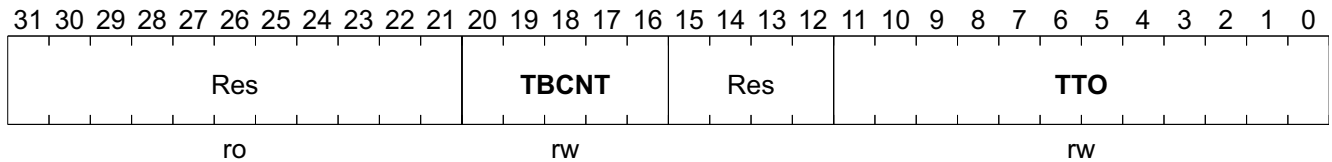

Field	Bits	Type	Description
Res	31:21	ro	<b>Reserved</b>
TBCNT	20:16	rw	<b>Transmit Burst Count</b> After this number of consecutive successful transmit, transmit completed interrupt will be generated. Continuously do this function if no reset.
TTO	11:0	rw	<b>Transmit Time-Out = (deferred time + back-off time)</b> When the TDIE (bit28 of ACSR7) is set, the timer is decreased in unit of 2.56 $\mu$ s (100M) or 25.6 $\mu$ s (10M). If the timer expires before another packet transmit begin, then the TDIE interrupt will be generated.

## Flash ROM (also the boot ROM) Port

**FROM\_CSR24** **Offset**  
**Flash ROM (also the boot ROM) Port** **A0<sub>H</sub>** **Reset Value**  
**8000 0000<sub>H</sub>**

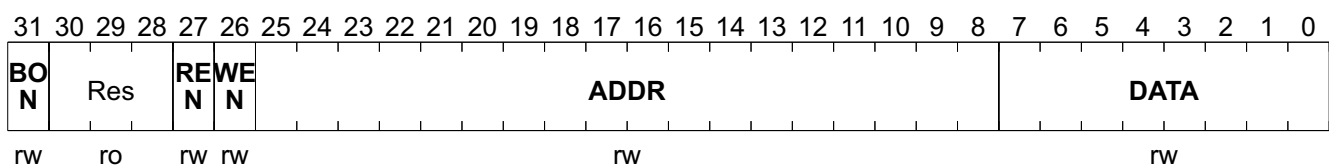

Field	Bits	Type	Description
BON	31	rw	<b>Bra16_on</b> This bit is only effective when 4 LED mode selected (bit 23 of CSR18 is set). When 4 LED mode selected, and this bit is set, then pin 105 is defined as brA16, else it is defined as LED pin – fd/col.
Res	30:28	ro	<b>Reserved</b>
REN	27	rw	<b>Read Enable</b> Clear if read data is ready in DATA, bit7-0 of FROM.
WEN	26	rw	<b>Write Enable</b> Cleared if write completed.
ADDR	25:8	rw	<b>Flash ROM Address</b>
DATA	7:0	rw	<b>Read/Write Data of Flash ROM</b>

## Registers and Descriptors Description PCI Control/Status Registers

**Physical Address Register 0**

Automatically recall from EEPROM

**PAR0\_CSR25** **Offset**  
**Physical Address Register 0** **A4<sub>H</sub>** **Reset Value**  
**xxxx xxxx<sub>H</sub>**

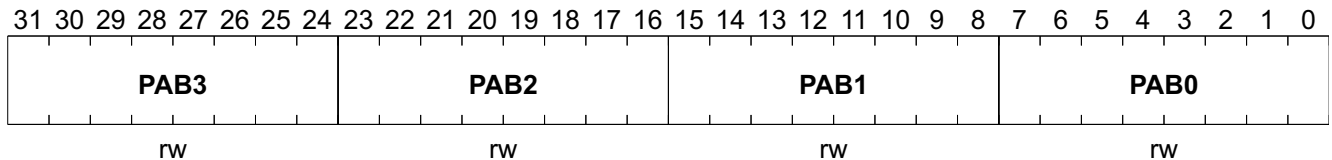

Field	Bits	Type	Description
PAB3	31:24	rw	<b>Physical Address Byte n</b> n = 0 to 3
PAB2	23:16	rw	
PAB1	15:8	rw	
PAB0	7:0	rw	

**Physical Address Register 1**

Automatically recall from EEPROM

**PAR1\_CSR26** **Offset**  
**Physical Address Register 1** **A8<sub>H</sub>** **Reset Value**  
**??<sub>H</sub>**

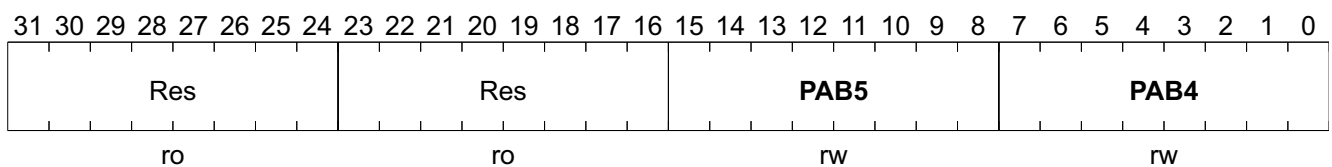

Field	Bits	Type	Description
Res	31:24	ro	<b>Reserved</b>
Res	23:16	ro	<b>Reserved</b>
PAB5	15:8	rw	<b>Physical Address Byte 5</b>
PAB4	7:0	rw	<b>Physical Address Byte 4</b>

For example, physical address = 00-00-e8-11-22-33

PAR0 = 11 e8 00 00

PAR1 = xx xx 33 22

PAR0 and PAR1 are readable, but can be written only if the receive state is in stopped (CSR5 bit19-17 = 000).

**Multicast Address Register 0**



Registers and Descriptors Description PCI Control/Status Registers

**MAR0\_CSR27** **Offset** **Reset Value**  
**Multicast Address Register 0** **AC<sub>H</sub>** **0000 0000<sub>H</sub>**

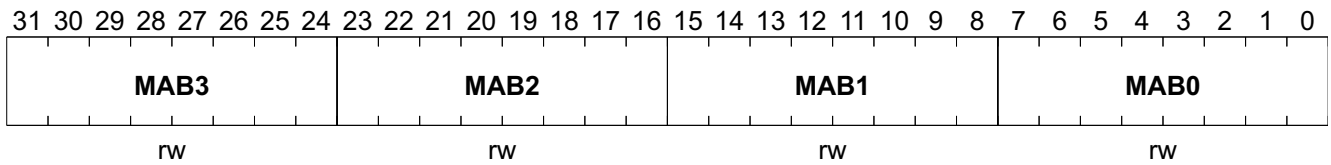

Field	Bits	Type	Description
MAB3	31:24	rw	<b>Multicast Address Byte n</b> n = 0 to 3
MAB2	23:16	rw	
MAB1	15:8	rw	
MAB0	7:0	rw	

**Multicast Address Register 1**

**MAR1\_CSR28** **Offset** **Reset Value**  
**Multicast Address Register 1** **B0<sub>H</sub>** **0000 0000<sub>H</sub>**

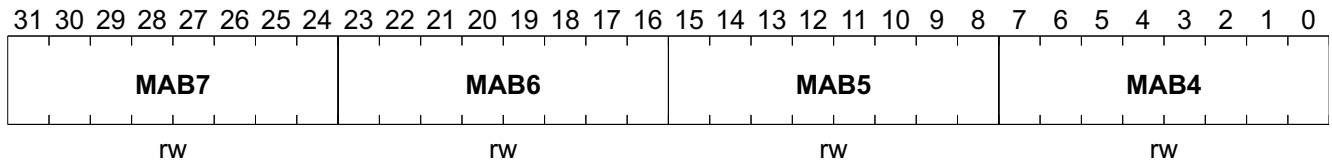

Field	Bits	Type	Description
MAB7	31:24	rw	Multicast Address Byte 7 (hash table 63:56)
MAB6	23:16	rw	Multicast Address Byte 6 (hash table 55:48)
MAB5	15:8	rw	Multicast Address Byte 5 (hash table 47:40)
MAB4	7:0	rw	Multicast Address Byte 4 (hash table 39:32)

**MAR0 and MAR1 are readable, but can be written** only if the receive state is in stopped (CSR5 bit19-17 = 000).

**Multicast 64 Algorithm**

AN983B/BX uses CRC [5:0] to hit one of the 64 entries in UMAR1 [31:0] and MAR0[31:0] by generated CRC32 from Ethernet DA (destination address).

The most significant bit CRC [5] chooses the upper or lower double word, (MAR1 or MAR0), the lower 5 bit presents for the corresponding bit inside the double word.

Example 1:

If CRC [5] = 1'b0 --> hit MAR0

CRC [4:0] = 5'b00010 --> hit MAR0 [2]

Example 2:

CRC [5] = 1'b1 --> hit MAR1

CRC [4:0] = 5'b00100 --> hit MAR1 [4]



Registers and Descriptors Description PCI Control/Status Registers

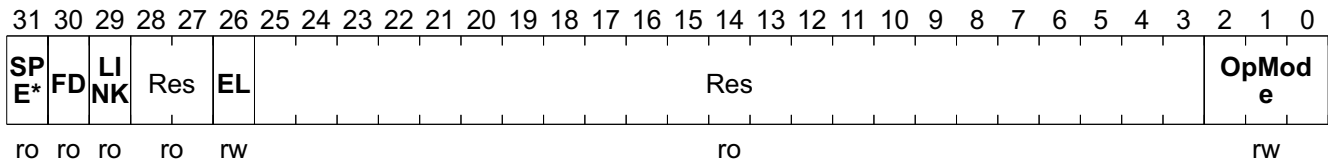

Field	Bits	Type	Description
SPEED	31	ro	<b>Network Speed Status</b> 0 <sub>B</sub> , 10M 1 <sub>B</sub> , 100M
FD	30	ro	<b>Full/Half Duplex Status</b> 0 <sub>B</sub> , Half duplex 1 <sub>B</sub> , Full duplex
LINK	29	ro	<b>Network Link Status</b> 0 <sub>B</sub> , Link off 1 <sub>B</sub> , Link on
Res	28:27	ro	<b>Reserved</b>
EL	26	rw	<b>EERLOD</b> Write 1 and this bit will cause AN983B/BX to reload data from EEPROM. After reload completed, this bit will be cleared automatically.
Res	25:3	ro	<b>Reserved</b>
OpMode	2:0	rw	<b>Operation Mode</b> These three bits are used to configure AN983B/BX's operation mode: 111b: Single Chip mode (Normal operation) At this mode, AN983B/BX is configured as single chip to provide PCI to Ethernet controller. 100b: MAC-only mode The AN983B/BX is configured as a MAC only controller, it provides standard MII interface to link to the external PHY. The MII interface pins are multiplexed with BootROM interface. Others: For diagnostic purpose

### 9.3 PHY Registers (Accessed by CSR9 MDI/MMC/MDO/MDC)

**Table 15 Registers Address Space**

Module	Base Address	End Address	Note
PHY	0000 0000 <sub>H</sub>	0000 0006 <sub>H</sub>	

**Table 16 Registers Overview**

Register Short Name	Register Long Name	Offset Address	Page Number
<b>R0</b>	Register 0 (MII Control)	0 <sub>H</sub>	<b>86</b>
<b>R1</b>	Register 1 (Status)	1 <sub>H</sub>	<b>88</b>
<b>R2</b>	Register 2	2 <sub>H</sub>	<b>90</b>
<b>R3</b>	Register 3	3 <sub>H</sub>	<b>90</b>
<b>R4</b>	Register 4	4 <sub>H</sub>	<b>91</b>
<b>R5</b>	Register 5	5 <sub>H</sub>	<b>92</b>
<b>R6</b>	Register 6	6 <sub>H</sub>	<b>93</b>

The register is addressed wordwise.

Standard abbreviations:

**Table 17 Registers Access Types**

Mode	Symbol	Description Hardware (HW)	Description Software (SW)
read/write	rw	Register is used as input for the HW	Register is readable and writable by SW
read	r	Register is written by HW (register between input and output -> one cycle delay)	Value written by software is ignored by hardware; that is, software may write any value to this field without affecting hardware behavior (= Target for development.)
write	w		Register is writable by SW
read/write hardware affected	rwh	Register can be modified by HW	Register can be modified by HW, but the priority SW versus HW has to be specified
	rww		
Read only	ro	Register is set by HW (register between input and output -> one cycle delay)	SW can only read this register
Read virtual	rv	Physically, there is no new register, the input of the signal is connected directly to the address multiplexer.	SW can only read this register
Latch high, self clearing	lhsc	Latch high signal at high level, clear on read	SW can read the register
Latch low, self clearing	llsc	Latch high signal at low-level, clear on read	SW can read the register
Latch high, mask clearing	lhmk	Latch high signal at high level, register cleared with written mask	SW can read the register, with write mask the register can be cleared (1 clears)

Registers and Descriptors Description PHY Registers (Accessed by CSR9)

**Table 17 Registers Access Types (cont'd)**

Mode	Symbol	Description Hardware (HW)	Description Software (SW)
Latch low, mask clearing	llmk	Latch high signal at low-level, register cleared on read	SW can read the register, with write mask the register can be cleared (1 clears)
Interrupt high, self clearing	ihsc	Differentiate the input signal (low->high) register cleared on read	SW can read the register
Interrupt low, self clearing	ilsc	Differentiate the input signal (high->low) register cleared on read	SW can read the register
Interrupt high, mask clearing	ihmk	Differentiate the input signal (high->low) register cleared with written mask	SW can read the register, with write mask the register can be cleared
Interrupt low, mask clearing	ilmk	Differentiate the input signal (low->high) register cleared with written mask	SW can read the register, with write mask the register can be cleared
Interrupt enable register	ien	Enables the interrupt source for interrupt generation	SW can read and write this register
latch_on_reset	lor	rw register, value is latched after first clock cycle after reset	Register is read and writable by SW
Read/write self clearing	rwsc	Register is used as input for the hw, the register will be cleared due to a HW mechanism.	Writing to the register generates a strobe signal for the HW (1 pdi clock cycle) Register is readable and writable by SW.

**9.3.1 PHY Transceiver Registers Descriptions**

**Register 0**

MII Control

**R0** **Offset**  
**Register 0(MII Control)** **0<sub>H</sub>** **Reset Value**  
**1000<sub>H</sub>**

15	14	13	12	11	10	9	8	7	6	5	4	3	2	1	0
<b>RESET</b>	<b>LOOP</b>	<b>SPEED</b>	<b>ANE</b>	<b>PD</b>	<b>IS</b>	<b>RAN</b>	<b>DM</b>	<b>CT</b>							
rwsc	rw	rw	rw	rw	rw	rwsc	rw	ro							ro

Field	Bits	Type	Description
RESET	15	rwsc	<b>Reset</b> 0 <sub>B</sub> , normal operation 1 <sub>B</sub> , PHY Reset
LOOP	14	rw	<b>Loopback</b> 0 <sub>B</sub> , disable loopback 1 <sub>B</sub> , enable loopback

## Registers and Descriptors Description PHY Registers (Accessed by CSR9)

Field	Bits	Type	Description
SPEED	13	rw	<b>Speed Selection</b> 0 <sub>B</sub> , 10 Mbit/s 1 <sub>B</sub> , 100 Mbit/s
ANE	12	rw	<b>Autonegotiation Enable</b> 0 <sub>B</sub> , disable autoneg 1 <sub>B</sub> , enable autoneg
PD	11	rw	<b>Power Down</b> 0 <sub>B</sub> , normal operation 1 <sub>B</sub> , Power Down
IS	10	rw	<b>Isolate</b> 0 <sub>B</sub> , normal operation 1 <sub>B</sub> , isolate PHY from MII
RAN	9	rwsc	<b>Restart Autonegotiation</b> 1 <sub>B</sub> , Restart Autoneg
DM	8	rw	<b>Duplex Mode</b> 0 <sub>B</sub> , half duplex 1 <sub>B</sub> , full duplex
CT	7	ro	<b>Collision Test</b> Not implemented
Res	6:0	ro	<b>Reserved</b>

**SC:** Self Clearing

**Reset:** Reset this port only. This will cause the following:

1. Restart the autonegotiation process.
2. Reset the registers to their default values. Note that this does not affect registers 20, 22, 30 or 31. These registers are not reset by this bit to allow test configurations to be written and then not to be affected by resetting the port.

*Note: No reset is performed to analogue sections of the port. There is also no physical reset to any internal clock synthesizers or the local clock recovery oscillator which will continue to run throughout the reset period.*

*However since the port is restarted and autoneg re-run the process of locking the frequency of the local oscillator (slave) to the reference oscillator (master) will be repeated as it is at the start of any link initialization process.*

**Loopback:** Loop back of transmit data to receive via a path as close to the wire as possible. When set inhibits actual transmission on the wire.

**Speed selection:** Forces speed of Phy only when autonegotiation is disabled. The default state of this bit will be determined by a power-up configuration pin in this case. Otherwise it defaults to 1.

Auto-neg enable Defaults to pin programmed value. When cleared allows forcing of speed and duplex settings. When set (after being cleared) causes re-start of autoneg process. Pin programming at power-up allows it to come up disabled and for software to write the desired capability before allowing the first negotiation to commence.

**Restart Negotiation:** only has effect when autonegotiating. Restarts state machine.

**Power down:** Has no effect in this device. Test mode power down modes may be implemented in other specific modules.

**Isolate:** Puts RMII receive signals into high impedance state and ignores transmit signals.

**Duplex mode:** When bit12 is cleared (i.e. autoneg disabled), this bit forces full duplex (bit = 1) or half duplex (bit = 0).

## Registers and Descriptors Description PHY Registers (Accessed by CSR9)

**Collision test:** Always 0 because collision signal is not implemented.

**Register 1**

Status

<b>R1</b>		<b>Offset</b>	<b>Reset Value</b>
<b>Register 1 (Status)</b>		<b>1<sub>H</sub></b>	<b>7849<sub>H</sub></b>

15	14	13	12	11	10	9	8	7	6	5	4	3	2	1	0
<b>100B T4</b>	<b>100B FD</b>	<b>100B HD</b>	<b>10FD</b>	<b>10HD</b>	<b>100B T2FD</b>	<b>100B T2HD</b>	Res		<b>MFPS</b>	<b>AC</b>	<b>RF</b>	<b>AA</b>	<b>LS</b>	<b>JD</b>	<b>EC</b>
ro	ro	ro	ro	ro	ro	ro	ro		ro	ro	ro, lh	ro	ro, ll	ro, lh	ro

Field	Bits	Type	Description
100BT4	15	ro	<b>100 BASE T4</b> Not supported
100BFD	14	ro	<b>100 BASE-X Full Duplex</b> 0 <sub>B</sub> , PHY is not 100BASE-X full duplex capable 1 <sub>B</sub> , PHY is 100BASE-X full duplex capable
100BHD	13	ro	<b>100BASE-X Half Duplex</b> 0 <sub>B</sub> , PHY is not 100BASE-X half duplex capable 1 <sub>B</sub> , PHY is 100BASE-X half duplex capable
10FD	12	ro	<b>10 Mbit/s Full Duplex</b> 0 <sub>B</sub> , PHY is not 10 Mbit/s/s Full duplex capable 1 <sub>B</sub> , PHY is 10 Mbit/s/s Full duplex capable
10HD	11	ro	<b>10 Mbit/s Half Duplex</b> 0 <sub>B</sub> , PHY is not 10 Mbit/s/s Half duplex capable 1 <sub>B</sub> , PHY is 10 Mbit/s/s Half duplex capable
100BT2FD	10	ro	<b>100BASE-T2 Full Duplex</b> Not supported
100BT2HD	9	ro	<b>100BASE-T2 Half Duplex</b> Not supported
Res	8:7	ro	<b>Reserved</b>
MFPS	6	ro	<b>MF Preamble Suppression</b> 0 <sub>B</sub> , PHY cannot accept management frames with preamble suppression 1 <sub>B</sub> , PHY can accept management frames with preamble suppression
AC	5	ro	<b>Autoneg Complete</b> 0 <sub>B</sub> , autoneg incomplete 1 <sub>B</sub> , autoneg completed
RF	4	ro, lh	<b>Remote Fault</b> <i>Note: lh: Latch High</i> 0 <sub>B</sub> , no remote fault detected 1 <sub>B</sub> , remote fault detected



## Registers and Descriptors Description PHY Registers (Accessed by CSR9)

Field	Bits	Type	Description
AA	3	ro	<b>Autoneg Ability</b> 0 <sub>B</sub> , PHY cannot auto-negotiate 1 <sub>B</sub> , PHY can auto-negotiate
LS	2	ro, ll	<b>Link Status</b> <i>Note: lh: Latch Low</i> 0 <sub>B</sub> , link is down 1 <sub>B</sub> , link is up
JD	1	ro, lh	<b>Jabber Detect</b> Only used in 10Base-T mode. Read as 0 in 100Base-TX mode. <i>Note: lh: Latch High</i> 1 <sub>B</sub> , jabber condition detected
EC	0	ro	<b>Extended Capability</b> 0 <sub>B</sub> , basic register set capabilities only 1 <sub>B</sub> , extended register set capabilities

**Register 2 and 3**

Each PHY has an identifier, which is assigned to the device.

The identifier contains a total of 32 bits, which consists of the following: 22 bits of a 24bit organizationally unique identifier (OUI) for the manufacturer; a 6-bit manufacturer's model number; a 4-bit manufacturer's revision number. For an explanation of how the OUI maps to the register, please refer to IEEE 802-1990 clause 5.1.

Registers and Descriptors Description PHY Registers (Accessed by CSR9)

Register 2

**R2** **Offset** **Reset Value**  
**Register 2** **2<sub>H</sub>** **001D<sub>H</sub>**

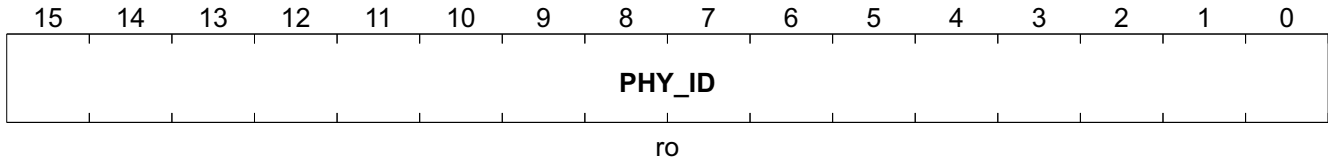

Field	Bits	Type	Description
PHY_ID	15:0	ro	<b>PHY_ID[31-16]</b> OUI (bits 3-18)

Register 3

**R3** **Offset** **Reset Value**  
**Register 3** **3<sub>H</sub>** **2411<sub>H</sub>**

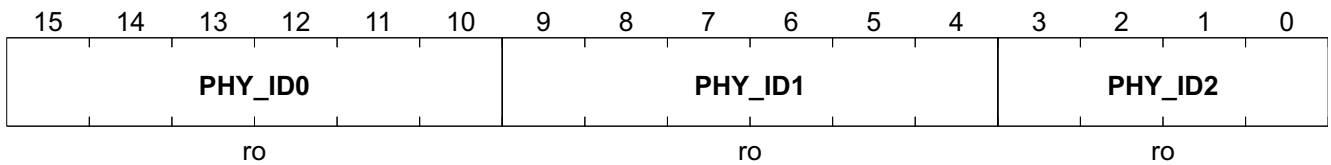

Field	Bits	Type	Description
PHY_ID0	15:10	ro	<b>PHY_ID[15-10]</b> OUI (bits 19-24)
PHY_ID1	9:4	ro	<b>PHY_ID[9-4]</b> Manufacturer's Model Number (bits 5-0)
PHY_ID2	3:0	ro	<b>PHY_ID[3-0]</b> Revision Number (bits 3-0); Register 3, bit 0 is LS bit of PHY Identifier

**This uses the OUI of Infineon-ADMtek, device type of 1 and rev 0**

## Registers and Descriptors Description PHY Registers (Accessed by CSR9)

## Register 4

**R4** **Offset** **Reset Value**  
**Register 4** **4<sub>H</sub>** **0001<sub>H</sub>**

15	14	13	12	11	10	9	8	7	6	5	4	3	2	1	0
<b>NP</b>	<b>Res</b>	<b>RF</b>	<b>NI1</b>	<b>PAUSE</b>	<b>NI2</b>	<b>100BFD</b>	<b>100BHD</b>	<b>10BFD</b>	<b>10BHD</b>				<b>SF</b>		
rw	ro	rw	ro	rw	ro	rw	rw	rw	rw				ro		

Field	Bits	Type	Description
NP	15	rw	<b>Next Page</b> 0 <sub>B</sub> , Device not set to use Next Page 1 <sub>B</sub> , Device set to use Next Page
Res	14	ro	<b>Reserved</b>
RF	13	rw	<b>Remote Fault</b> 0 <sub>B</sub> , no fault detected 1 <sub>B</sub> , Local remote fault sent to link partner
NI1	12:11	ro	<b>Not Implemented</b> Technology ability bits A7-A6
PAUSE	10	rw	<b>Pause</b> Technology ability bit A5
NI2	9	ro	<b>Not Implemented</b> Technology ability bit A4
100BFD	8	rw	<b>100BASE-TX Full Duplex</b> Technology ability bit A3 0 <sub>B</sub> , Unit is not capable of Full Duplex 1 <sub>B</sub> , Unit is capable of Full Duplex
100BHD	7	rw	<b>100BASE-TX Half Duplex</b> Technology ability bit A2 0 <sub>B</sub> , Unit is not capable of Half Duplex 100BASE-TX 1 <sub>B</sub> , Unit is capable of Half Duplex
10BFD	6	rw	<b>10BASE-T Full Duplex</b> Technology ability bit A1 0 <sub>B</sub> , Unit is not capable of Full Duplex 10BASE-T 1 <sub>B</sub> , Unit is capable of Full Duplex 10BASE-T
10BHD	5	rw	<b>10BASE-T Half Duplex</b> Technology ability bit A0 0 <sub>B</sub> , Unit is not capable of Half Duplex 10BASE-T 1 <sub>B</sub> , Unit is capable of Half Duplex 10BASE-T
SF	4:0	ro	<b>Selector Field</b> Identifies the type of message being sent. Currently only one value is defined.

Registers and Descriptors Description PHY Registers (Accessed by CSR9)

**Register 5**

The register is used to view the advertised capabilities of the link partner once autonegotiation is complete. The contents of this register should not be relied upon unless register 1 bit 5 is set (autoneg complete). After negotiation this register should contain a copy of the link partner's register 4. All bits are therefore defined in the same way as for register 4.

All bits are readable only.

This register is used for Base Page code word only.

Base Page Register Format

**R5** **Offset**  
**Register 5** **5<sub>H</sub>** **Reset Value**  
**0000 0000<sub>H</sub>**

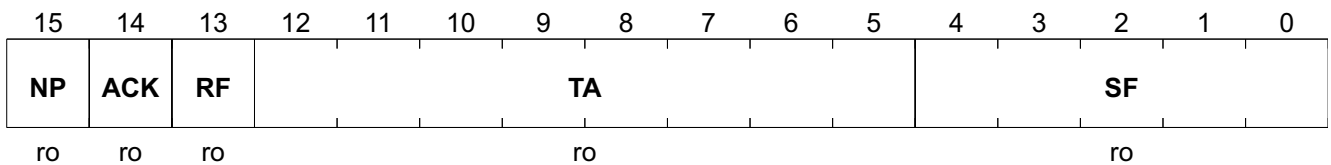

Field	Bits	Type	Description
NP	15	ro	<b>Next Page</b> 0 <sub>B</sub> , Base Page is requested 1 <sub>B</sub> , Link Partner is requesting Next Page function
ACK	14	ro	<b>Acknowledge</b> Link Partner acknowledgement bit
RF	13	ro	<b>Remote Fault</b> Link Partner is indicating a fault
TA	12:5	ro	<b>Technology Ability</b> Link Partner technology ability field.
SF	4:0	ro	<b>Selector Field</b> Link Partner selector field

## Registers and Descriptors Description PHY Registers (Accessed by CSR9)

## Register 6

**R6** **Offset** **Reset Value**  
**Register 6** **6<sub>H</sub>** **0004<sub>H</sub>**

15	14	13	12	11	10	9	8	7	6	5	4	3	2	1	0
Res											PDF	LPNP	NP	PR	LAAA
ro											ro, lh	ro	ro	ro, lh	ro

Field	Bits	Type	Description
Res	15:5	ro	<b>Reserved</b>
PDF	4	ro, lh	<b>Parallel Detection Fault</b> <i>Note: lh: Latch High</i> 0 <sub>B</sub> , No fault detected 1 <sub>B</sub> , Local Device Parallel Detection Fault
LPNP	3	ro	<b>Link Partner Next Page Able</b> 0 <sub>B</sub> , Link Partner is not Next Page Able 1 <sub>B</sub> , Link Partner is Next Page Able
NP	2	ro	<b>Next Page Able</b> 0 <sub>B</sub> , Local device is not Next Page Able 1 <sub>B</sub> , Local device is Next Page Able
PR	1	ro, lh	<b>Page Received</b> <i>Note: lh: Latch High</i> 0 <sub>B</sub> , A New Page has not been received 1 <sub>B</sub> , A New Page has been received
LAAA	0	ro	<b>Link Partner Autonegotiation Able</b> 0 <sub>B</sub> , Link Partner is not Autonegotiation able 1 <sub>B</sub> , Link Partner is Autonegotiation able

**LH: Latch High**

## 9.4 Descriptors and Buffer Management

**Table 18 Registers Overview**

Register Short Name	Register Long Name	Offset Address	Page Number
<a href="#">RDES0</a>	RDES0	00 <sub>H</sub>	<a href="#">95</a>
<a href="#">RDES1</a>	RDES1	04 <sub>H</sub>	<a href="#">98</a>
<a href="#">RDES2</a>	RDES2	08 <sub>H</sub>	<a href="#">98</a>
<a href="#">RDES3</a>	RDES3	0Ch <sub>H</sub>	<a href="#">98</a>
<a href="#">TDES0</a>	TDES0	00 <sub>H</sub>	<a href="#">99</a>
<a href="#">TDES1</a>	TDES1	04 <sub>H</sub>	<a href="#">100</a>
<a href="#">TDES2</a>	TDES2	08 <sub>H</sub>	<a href="#">101</a>
<a href="#">TDES3</a>	TDES3	0Ch <sub>H</sub>	<a href="#">101</a>

The register is addressed wordwise.

Standard abbreviations:

**Table 19 Registers Access Types**

Mode	Symbol	Description Hardware (HW)	Description Software (SW)
read/write	rw	Register is used as input for the HW	Register is readable and writable by SW
read	r	Register is written by HW (register between input and output -> one cycle delay)	Value written by software is ignored by hardware; that is, software may write any value to this field without affecting hardware behavior (= Target for development.)
write	w		Register is writable by SW
read/write hardware affected	rwh	Register can be modified by HW	Register can be modified by HW, but the priority SW versus HW has to be specified
	rwv		
Read only	ro	Register is set by HW (register between input and output -> one cycle delay)	SW can only read this register
Read virtual	rv	Physically, there is no new register, the input of the signal is connected directly to the address multiplexer.	SW can only read this register
Latch high, self clearing	lhsc	Latch high signal at high level, clear on read	SW can read the register
Latch low, self clearing	llsc	Latch high signal at low-level, clear on read	SW can read the register
Latch high, mask clearing	lhmk	Latch high signal at high level, register cleared with written mask	SW can read the register, with write mask the register can be cleared (1 clears)
Latch low, mask clearing	llmk	Latch high signal at low-level, register cleared on read	SW can read the register, with write mask the register can be cleared (1 clears)

**Table 19 Registers Access Types (cont'd)**

Mode	Symbol	Description Hardware (HW)	Description Software (SW)
Interrupt high, self clearing	ihsc	Differentiate the input signal (low->high) register cleared on read	SW can read the register
Interrupt low, self clearing	ilsc	Differentiate the input signal (high->low) register cleared on read	SW can read the register
Interrupt high, mask clearing	ihmk	Differentiate the input signal (high->low) register cleared with written mask	SW can read the register, with write mask the register can be cleared
Interrupt low, mask clearing	ilmk	Differentiate the input signal (low->high) register cleared with written mask	SW can read the register, with write mask the register can be cleared
Interrupt enable register	ien	Enables the interrupt source for interrupt generation	SW can read and write this register
latch_on_reset	lor	rw register, value is latched after first clock cycle after reset	Register is readable and writable by SW
Read/write self clearing	rwsc	Register is used as input for the HW, the register will be cleared due to a HW mechanism.	Writing to the register generates a strobe signal for the HW (1 pdi clock cycle) Register is readable and writable by SW.

### 9.4.1 Receive Descriptor Descriptions

The AN983B/BX provides receive and transmit descriptors for packet buffering and management.

**Descriptors and receive buffers addresses must be longword alignment**

**Table 20 Receive Descriptor Table**

	31 ----- 0				
RDES0	Own	Status			
RDES1		---	Control	Buffer2 byte-count	Buffer1 byte-count
RDES2	Buffer1 address (DW boundary)				
RDES3	Buffer2 address (DW boundary)				

#### RDES0

RDES0	Offset	Reset Value
RDES0	00 <sub>H</sub>	xxxx xxxx <sub>H</sub>

31	30	29	28	27	26	25	24	23	22	21	20	19	18	17	16	15	14	13	12	11	10	9	8	7	6	5	4	3	2	1	0
OWN																ES	DE	DT	RF	MF	FS	LS	TL	CS	FTRW	Re <sub>s</sub>	DB	CE	OF		
rw																rw	rw	rw	rw	rw	rw	rw	rw	rw	rw	rw	rw	rw	rw	rw	

## Registers and Descriptors Description Descriptors and Buffer Management

Field	Bits	Type	Description
OWN	31	rw	<b>Own Bit</b> 0 <sub>B</sub> , Host does not move the receiving data out yet 1 <sub>B</sub> , indicates the new receiving data can be put into this descriptor
FL	30:16	rw	<b>Frame Length, Including CRC</b> This field is valid only in last descriptor
ES	15	rw	<b>Error Summary, OR of the Following Bit</b> This field is valid only in last descriptor. 0: overflow 1: CRC error 6: late collision 7: frame too long 11: small packet 14: descriptor error
DE	14	rw	<b>Descriptor Error</b> This bit is valid only in last descriptor 1 <sub>B</sub> , the current receiving packet is not able to put into the current valid descriptor. This packet is truncated
DT	13:12	rw	<b>Data Type</b> These bits are valid only in last descriptor 00 <sub>B</sub> , normal 01 <sub>B</sub> , MAC loop-back 10 <sub>B</sub> , Transceiver loop-back 11 <sub>B</sub> , remote loop-back
RF	11	rw	<b>Runt Frame (packet length &lt; 64 bytes)</b> This bit is valid only in last descriptor.
MF	10	rw	<b>Multicast Frame</b> This bit is valid only in last descriptor.
FS	9	rw	<b>First Descriptor</b>
LS	8	rw	<b>Last Descriptor</b>
TL	7	rw	<b>Too Long Packet (packet length &gt; 1518 bytes)</b> This bit is valid only in last descriptor.
CS	6	rw	<b>Late Collision</b> Set when collision is active after 64 bytes. This bit is valid only in last descriptor.
FT	5	rw	<b>Frame Type</b> This bit is valid only in last descriptor. 0 <sub>B</sub> , 802.3 type 1 <sub>B</sub> , Ethernet type
RW	4	rw	<b>Receive Watchdog (refer to CSR15, bit 4)</b> This bit is valid only in last descriptor.
Res	3	ro	<b>Reserved</b>
DB	2	rw	<b>Dribble Bit</b> This bit is valid only in last descriptor. ECPacket length is not integer multiple of 8-bit.
CE	1	rw	<b>CRC Error</b> This bit is valid only in last descriptor.



---

**Registers and Descriptors Description****Descriptors and Buffer Management**

Field	Bits	Type	Description
OF	0	rw	<b>Overflow</b> This bit is valid only in last descriptor.

## Registers and Descriptors Description Descriptors and Buffer Management

**RDES1**

<b>RDES1</b>	<b>Offset</b>	<b>Reset Value</b>
<b>RDES1</b>	<b>04<sub>H</sub></b>	<b>xxxx xxxx<sub>H</sub></b>

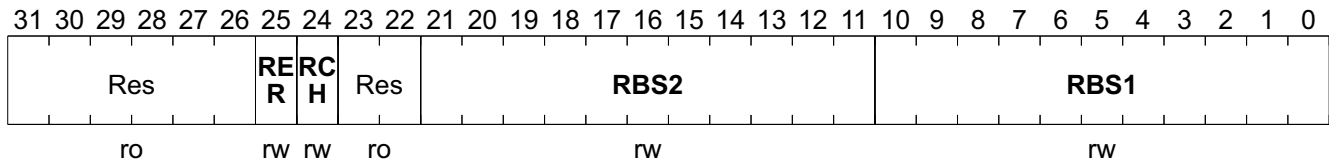

Field	Bits	Type	Description
Res	31:26	ro	<b>Reserved</b>
RER	25	rw	<b>Receive End of Ring</b> Indicates this descriptor is last, return to base address of descriptor.
RCH	24	rw	<b>Second Address Chain</b> Use for chain structure. Indicates the buffer2 address is the next descriptor address. Ring mode takes precedence over chained mode
Res	23:22	ro	<b>Reserved</b>
RBS2	21:11	rw	<b>Buffer 2 Size</b> DW boundary
RBS1	10:0	rw	<b>Buffer 1 Size</b> DW boundary

**RDES2**

<b>RDES2</b>	<b>Offset</b>	<b>Reset Value</b>
<b>RDES2</b>	<b>08<sub>H</sub></b>	<b>xxxx xxxx<sub>H</sub></b>

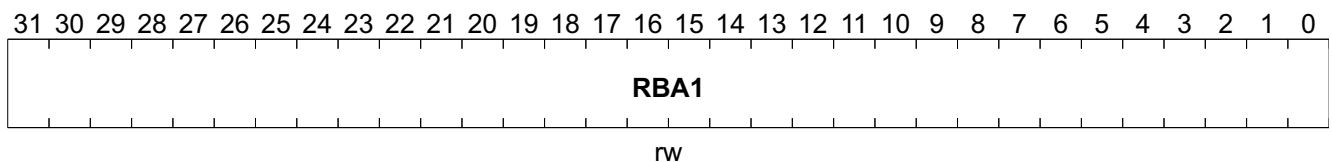

Field	Bits	Type	Description
RBA1	31:0	rw	<b>Receive Buffer Address 1</b> This buffer address should be double word aligned.

**RDES3**

## Registers and Descriptors Description Descriptors and Buffer Management

RDES3	Offset	Reset Value
RDES3	0Ch <sub>H</sub>	xxxx xxxx <sub>H</sub>

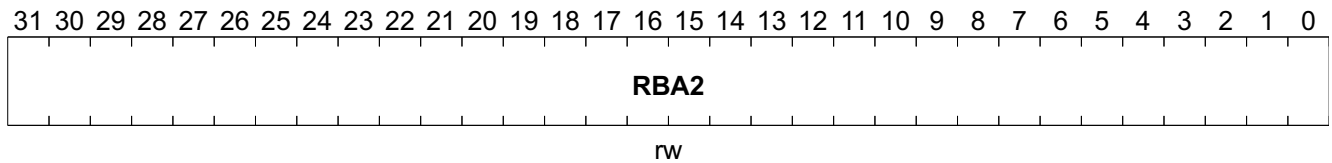

Field	Bits	Type	Description
RBA2	31:0	rw	<b>Receive Buffer Address 2</b> This buffer address should be double word aligned.

### 9.4.2 Transmit Descriptor Descriptions

The AN983B/BX provides receive and transmit descriptors for packet buffering and management.

**Descriptor addresses must be longword alignment**

**Table 21 Transmit Descriptor Table**

31 - 0			
TDES0	Own	Status	
TDES1	Control		Buffer2 byte-count      Buffer1 byte-count
TDES2	Buffer1 address		
TDES3	Buffer2 address		

#### TDES0

TDES0	Offset	Reset Value
TDES0	00 <sub>H</sub>	xxxx xxxx <sub>H</sub>

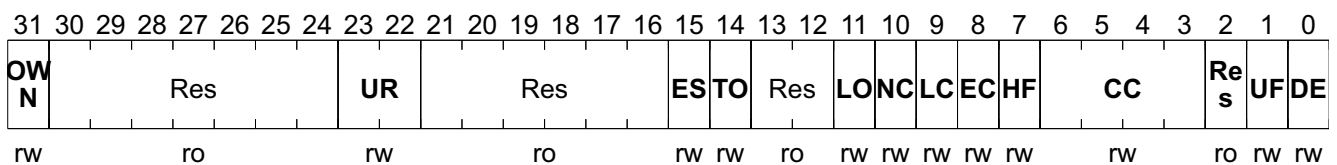

Field	Bits	Type	Description
OWN	31	rw	<b>Own Bit</b> 0 <sub>B</sub> , No transmit data in this descriptor for transmission 1 <sub>B</sub> , Indicate this descriptor is ready to transmit
Res	30:24	ro	<b>Reserved</b>
UR	23:22	rw	<b>Under-run Count</b>
Res	21:16	ro	<b>Reserved</b>

## Registers and Descriptors Description Descriptors and Buffer Management

Field	Bits	Type	Description
ES	15	rw	<b>Error Summary, OR of the Following Bit</b> 1: under-run error 8: excessive collision 9: late collision 10: no carrier 11: loss carrier 14: jabber time-out
TO	14	rw	<b>Transmit Jabber Time-out</b>
Res	13:12	ro	<b>Reserved</b>
LO	11	rw	<b>Loss Carrier</b>
NC	10	rw	<b>No Carrier</b>
LC	9	rw	<b>Late Collision</b>
EC	8	rw	<b>Excessive Collision</b>
HF	7	rw	<b>Heartbeat Fail</b>
CC	6:3	rw	<b>Collision Count</b>
Res	2	ro	<b>Reserved</b>
UF	1	rw	<b>Under-run Error</b>
DE	0	rw	<b>Deferred</b>

**TDES1**

TDES1	Offset	Reset Value
TDES1	04 <sub>H</sub>	xxxx xxxx <sub>H</sub>

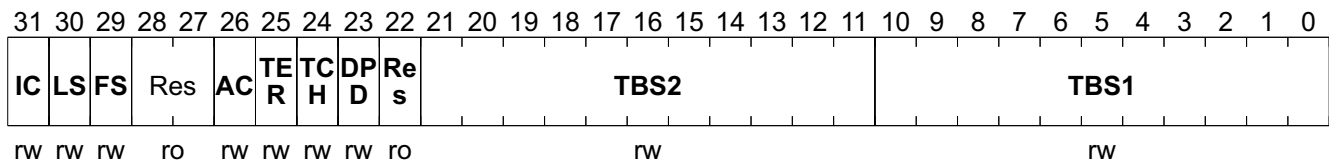

Field	Bits	Type	Description
IC	31	rw	<b>Interrupt Completed</b>
LS	30	rw	<b>Last Descriptor</b>
FS	29	rw	<b>First Descriptor</b>
Res	28:27	ro	<b>Reserved</b>
AC	26	rw	<b>Disable add CRC Function</b>
TER	25	rw	<b>End of Ring</b>
TCH	24	rw	<b>2nd Address Chain</b> Indicates the buffer2 address is the next descriptor address
DPD	23	rw	<b>Disable Padding Function</b>
Res	22	ro	<b>Reserved</b>
TBS2	21:11	rw	<b>Buffer 2 Size</b>
TBS1	10:0	rw	<b>Buffer 1 Size</b>



## 10 Electrical Specifications and Timings

### 10.1 Absolute Maximum Ratings

**Table 22 Min-Max Ratings**

Parameter	Symbol	Values			Unit	Note / Test Condition
		Min.	Typ.	Max.		
Supply Voltage	$V_{CC}$	-0.5	–	3.6	V	–
Input Voltage	$V_{CC}$	-0.5	–	$V_{CC} + 0.5$	V	
Output Voltage	$V_{CC}$	-0.5	–	$V_{CC} + 0.5$	V	
Storage Temperature	°C	- 65		150	°C	
Ambient Temperature	°C	0		70	°C	
ESD Protection				2000	V	

**Attention: Stresses above the max. values listed here may cause permanent damage to the device. Exposure to absolute maximum rating conditions for extended periods may affect device reliability. Maximum ratings are absolute ratings; exceeding only one of these values may cause irreversible damage to the integrated circuit.**

### 10.2 DC Specifications

**Table 23 General DC Specifications**

Parameter	Symbol	Values			Unit	Note / Test Condition
		Min.	Typ.	Max.		
Supply Voltage	$V_{CC}$	3.0	–	3.6	V	–
Power Supply	$I_{CC}$	–	150	–	mA	–

**Table 24 PCI Interface DC Specifications**

Parameter	Symbol	Values			Unit	Note / Test Condition
		Min.	Typ.	Max.		
Input LOW Voltage	$V_{ilp}$	-0.5	–	$0.325 V_{CC}$	V	–
Input HIGH Voltage	$V_{ihp}$	$0.475 V_{CC}$	–	$V_{CC} + 0.5$	V	–
Input Leakage Current	$I_{ilp}$	-10	–	10	μA	$0 < V_{in} < V_{CC}$
Output LOW Voltage	$V_{olp}$	–	–	$0.1 V_{CC}$	V	$I_{out} = 700 \mu A$
Output HIGH Voltage	$V_{ohp}$	$0.9 V_{CC}$	–	–	V	$I_{out} = -150 \mu A$
Input Pin Capacitance	$C_{inp}$	5	–	17	pF	–
CLK Pin Capacitance	$C_{clkp}$	10	–	22	pF	–

**Table 25 Flash/EEPROM Interface DC Specifications**

Parameter	Symbol	Values			Unit	Note / Test Condition
		Min.	Typ.	Max.		
Input LOW Voltage	$V_{ilf}$	0	–	$0.3 V_{CC}$	V	–
Input HIGH Voltage	$V_{ihf}$	$0.7 V_{CC}$	–	$V_{CC} + 1$	V	–
Input Leakage Current	$I_{if}$	-10	–	10	$\mu$ A	–
Output LOW Voltage	$V_{olf}$	–	–	0.2	V	–
Output HIGH Voltage	$V_{ohf}$	$V_{CC} - 0.2$	–	–	V	–
Input Pin Capacitance	$C_{inf}$	5	–	8	pF	–

### 10.3 AC Specifications

**Table 26 PCI Signaling AC Specifications for 3.3 V**

Parameter	Symbol	Values			Unit	Note / Test Condition
		Min.	Typ.	Max.		
Switching Current High	$I_{oh} (AC)$	–	4	–	mA	–
Switching Current Low	$I_{ol} (AC)$	–	6	–	mA	–
Slew Rate	–	0.25	–	1	V/ns	–
Unloaded Output Rise Time	$T_r$	1	–	4	V/ns	$0.2 V_{CC} \sim 0.6 V_{CC}$
Unloaded Output Fall Time	$T_f$	1	–	4	V/ns	$0.6 V_{CC} \sim 0.2 V_{CC}$

### 10.4 Timing Specifications

**Table 27 PCI Clock Specifications**

Parameter	Symbol	Values			Unit	Note / Test Condition
		Min.	Typ.	Max.		
Clock Cycle Time	$T_{cyc}$	30	–	–	ns	–
Clock High Time	$T_{high}$	12	–	–	ns	–
Clock Low Time	$T_{low}$	12	–	–	ns	–
Clock Slew Rate	–	1	–	4	V/ns	–

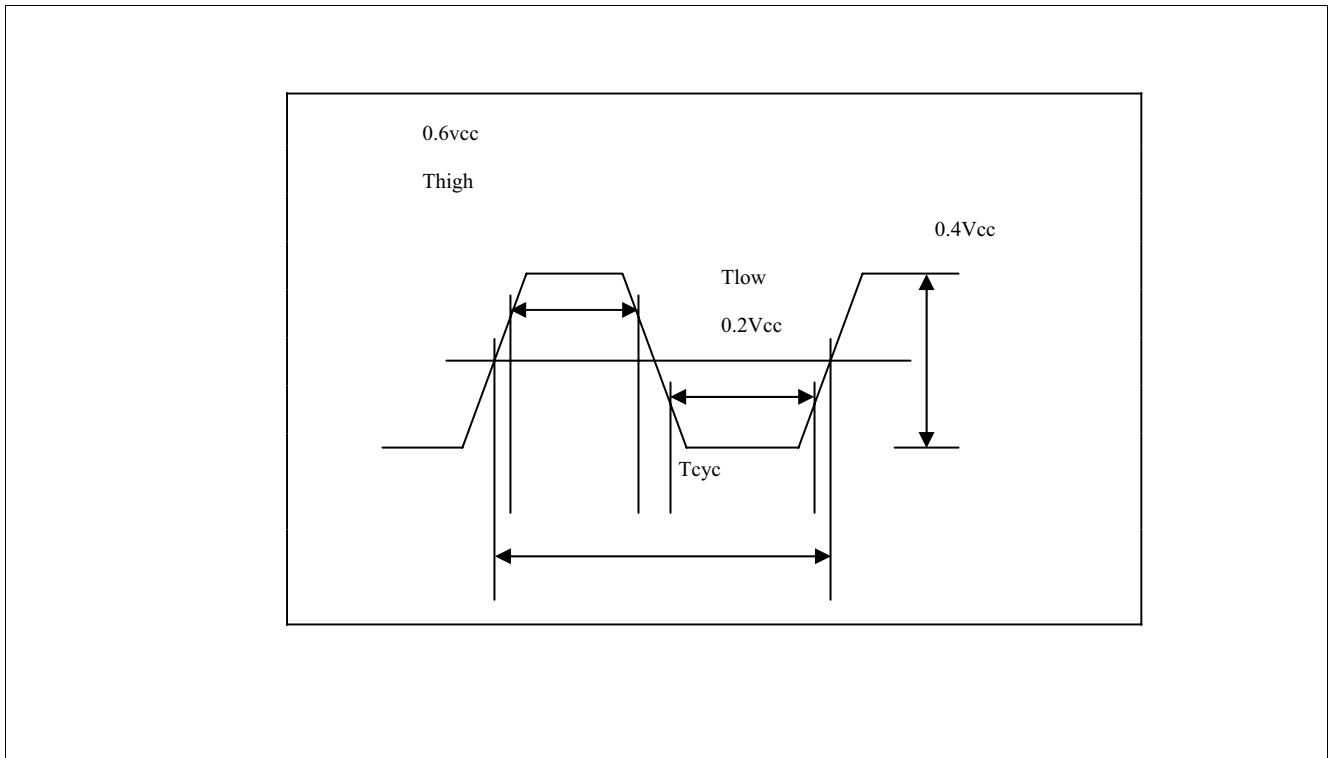

Figure 16 PCI Clock Waveform

Table 28 PCI Timings

Parameter	Symbol	Values			Unit	Note / Test Condition
		Min.	Typ.	Max.		
Access time – bus signals	$T_{val}$	2	–	11	ns	–
Access time – point to point	$T_{val} (ptp)$	2	–	12	ns	–
Float to Active Delay	$T_{on}$	2	–	–	ns	–
Active to Float Delay	$T_{off}$	–	–	28	ns	–
Input Set up Time to Clock – bus signals	$T_{su}$	7	–	–	ns	–
Input Set up Time to Clock – point to point	$T_{su} (ptp)$	10, 12	–	–	ns	–
Input Hold Time from Clock	$T_h$	0	–	–	ns	–
Reset Active Time after Power Stable	$T_{rst}$	1	–	–	ms	–
Reset Active Time after CLK Stable	$T_{rst-clk}$	100	–	–	$\mu$ s	–
Reset Active to Output Float delay	$T_{rst-off}$	–	–	40	ns	–



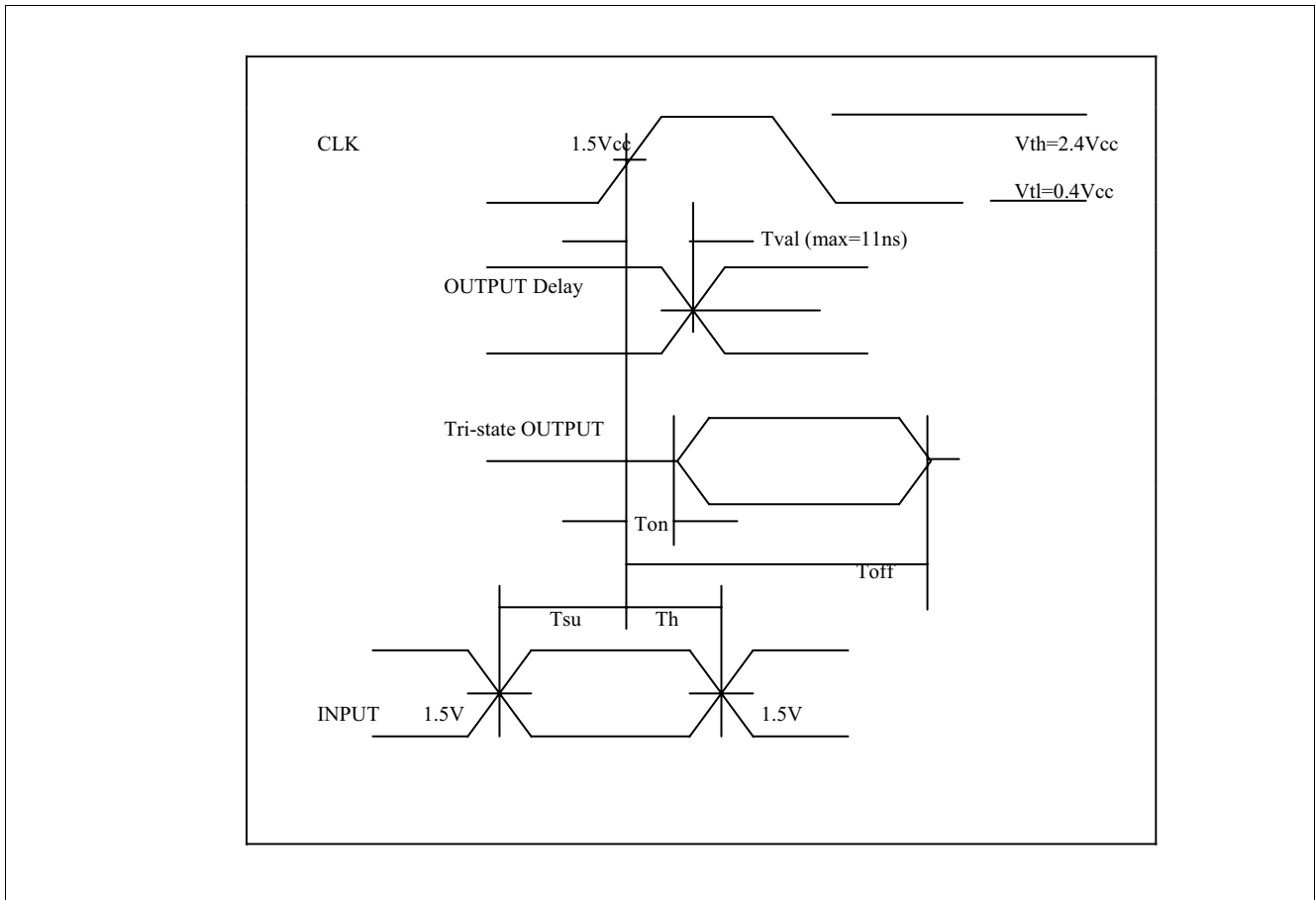

Figure 17 PCI Timings

Table 29 Flash Interface Timings

Parameter	Symbol	Values			Unit	Note / Test Condition
		Min.	Typ.	Max.		
Read cycle time	$T_{rc}$	90	–	–	ns	–
Chip enable access time	$T_{ce}$	–	–	90	ns	–
Address access time	$T_{aa}$	–	–	90	ns	–
Output enable access time	$T_{oe}$	–	–	45	ns	–
$\overline{CE}$ low to active output	$T_{clz}$	0	–	–	ns	–
$\overline{OE}$ low to active output	$T_{olz}$	0	–	–	ns	–
$\overline{CE}$ high to active output	$T_{chz}$	–	–	45	ns	–
$\overline{OE}$ high to active output	$T_{ohz}$	–	–	45	ns	–
Output hold from address change	$T_{oh}$	0	–	–	ns	–
Write cycle time	$T_{wc}$	–	–	10	ms	–
Address setup time	$T_{as}$	0	–	–	ns	–
Address hold time	$T_{ah}$	50	–	–	ns	–
$\overline{WE}$ and $\overline{CE}$ setup time	$T_{cs}$	0	–	–	ns	–
$\overline{WE}$ and $\overline{CE}$ hold time	$T_{ch}$	0	–	–	ns	–
$\overline{OE}$ high setup time	$T_{oes}$	10	–	–	ns	–

Table 29 Flash Interface Timings (cont'd)

Parameter	Symbol	Values			Unit	Note / Test Condition
		Min.	Typ.	Max.		
$\overline{\text{OE}}$ high hold time	$T_{\text{oeh}}$	10	–	–	ns	–
$\overline{\text{CE}}$ pulse width	$T_{\text{cp}}$	70	–	–	ns	–
$\overline{\text{WE}}$ pulse width	$T_{\text{wp}}$	70	–	–	ns	–
$\overline{\text{WE}}$ high width	$T_{\text{wph}}$	150	–	–	ns	–
Data setup time	$T_{\text{ds}}$	50	–	–	ns	–
Data hold time	$T_{\text{dh}}$	10	–	–	ns	–
Byte load cycle time	$T_{\text{blc}}$	0.22	–	200	$\mu\text{s}$	–
Byte load cycle time out	$T_{\text{blco}}$	300	–	–	$\mu\text{s}$	–

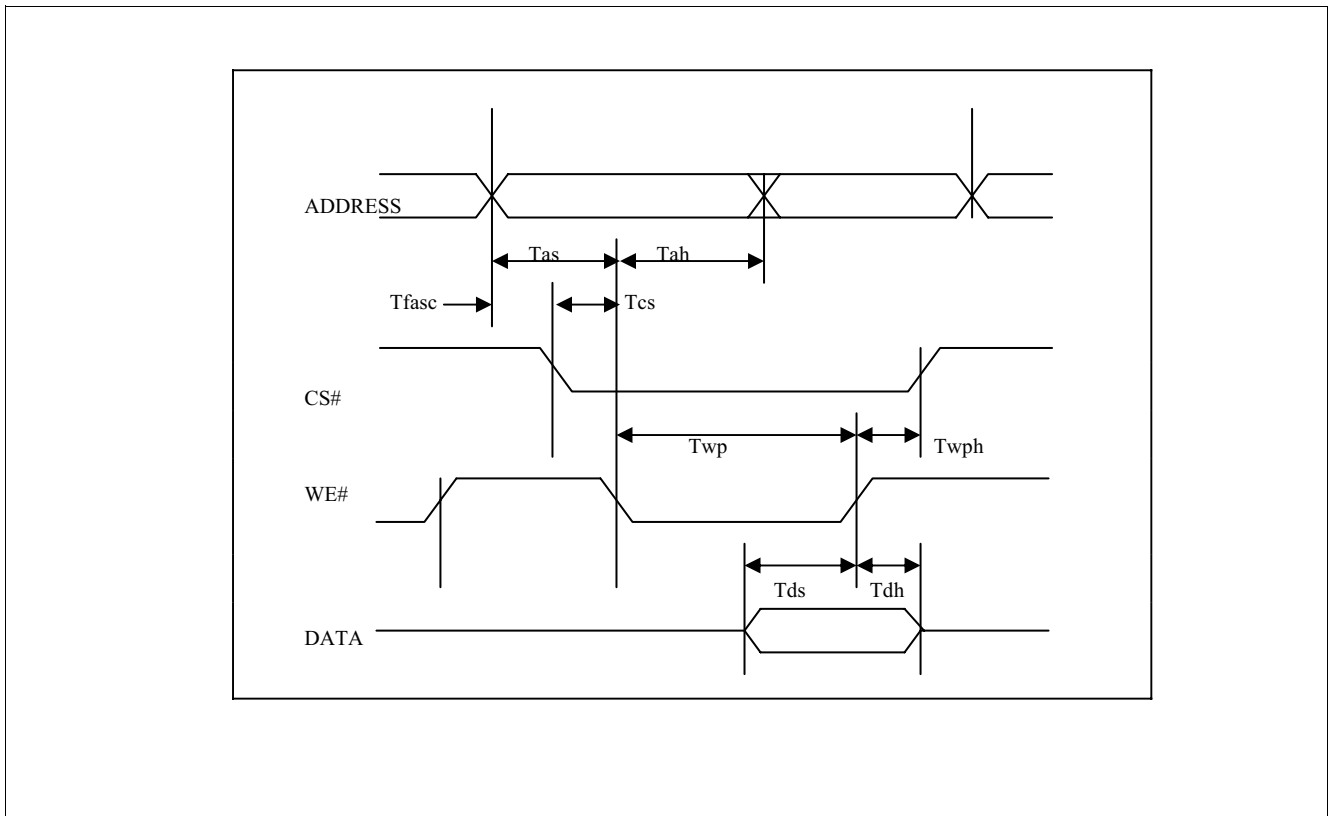

Figure 18 Flash Write Timings

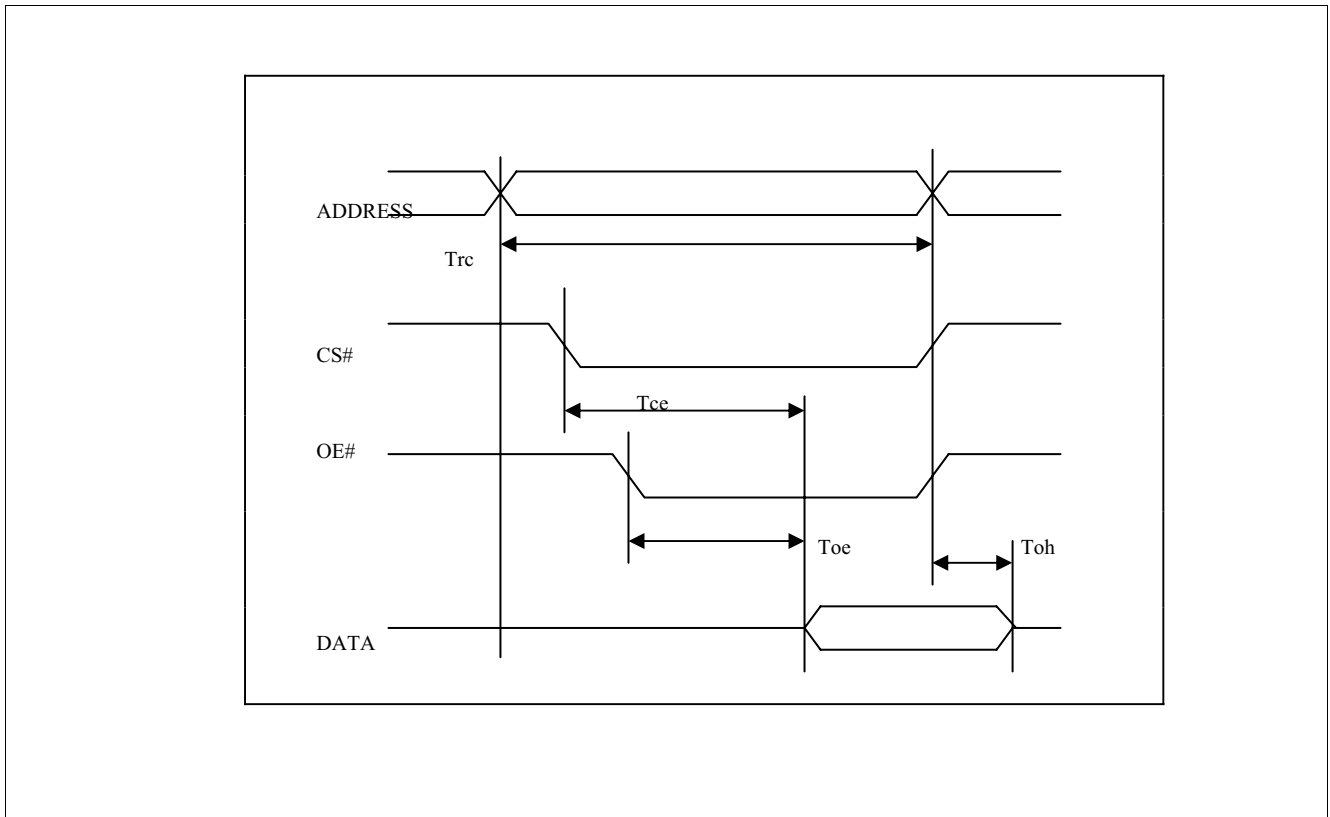

Figure 19 Flash Read Timings

Table 30 EEPROM Interface Timings (AC/AD)

Parameter	Symbol	Values			Unit	Note / Test Condition
		Min.	Typ.	Max.		
Serial Clock Frequency	T <sub>scf</sub>	–	–	0.4M/ 0.1M	Hz	2.7 V < V <sub>CC</sub> < 5.5 V
Delay from CS High to SK High	T <sub>ecss</sub>	160/640	–	–	ns	2.7 V < V <sub>CC</sub> < 5.5 V
Delay from SK Low to CS Low	T <sub>ecsh</sub>	1120/ 4480	–	–	ns	2.7 V < V <sub>CC</sub> < 5.5 V
Setup Time of DI to SK	T <sub>edts</sub>	160/640	–	–	ns	2.7 V < V <sub>CC</sub> < 5.5 V
Hold Time of DI after SK	T <sub>edth</sub>	2320/ 9280	–	–	ns	2.7 V < V <sub>CC</sub> < 5.5 V
CS Low Time	T <sub>ecsl</sub>	7400/ 29600	–	–	ns	2.7 V < V <sub>CC</sub> < 5.5 V

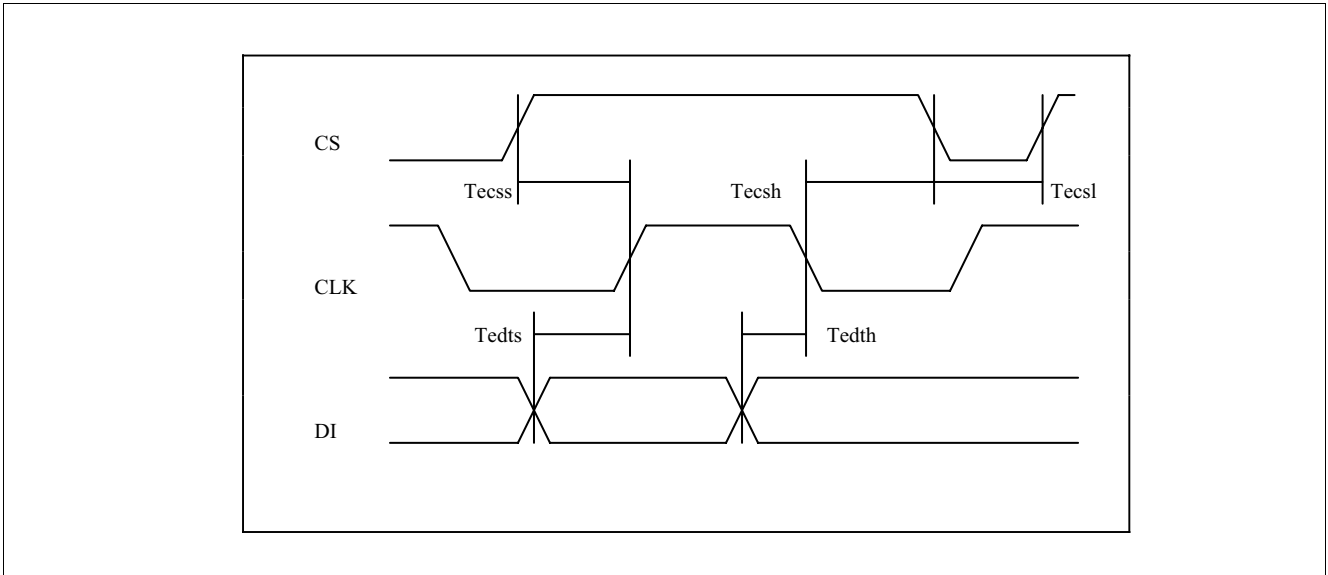

Figure 20 Serial EEPROM Timing

MII Interface Timing

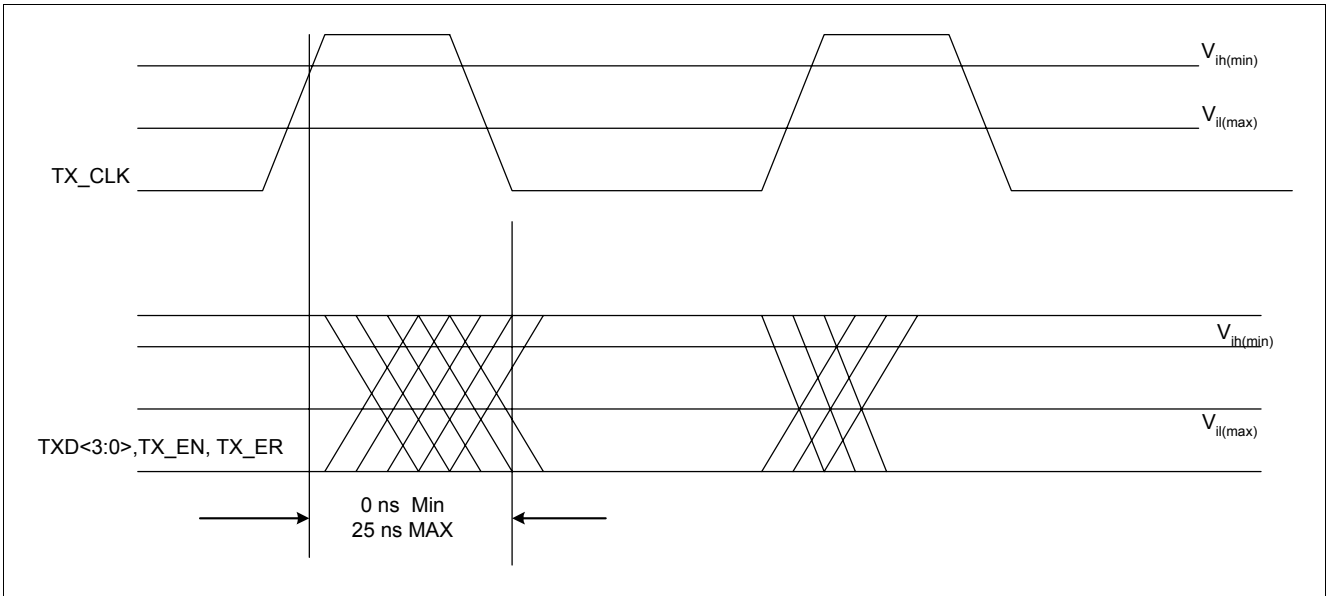

Figure 21 Transmit Signal Timing Relationships at the MII

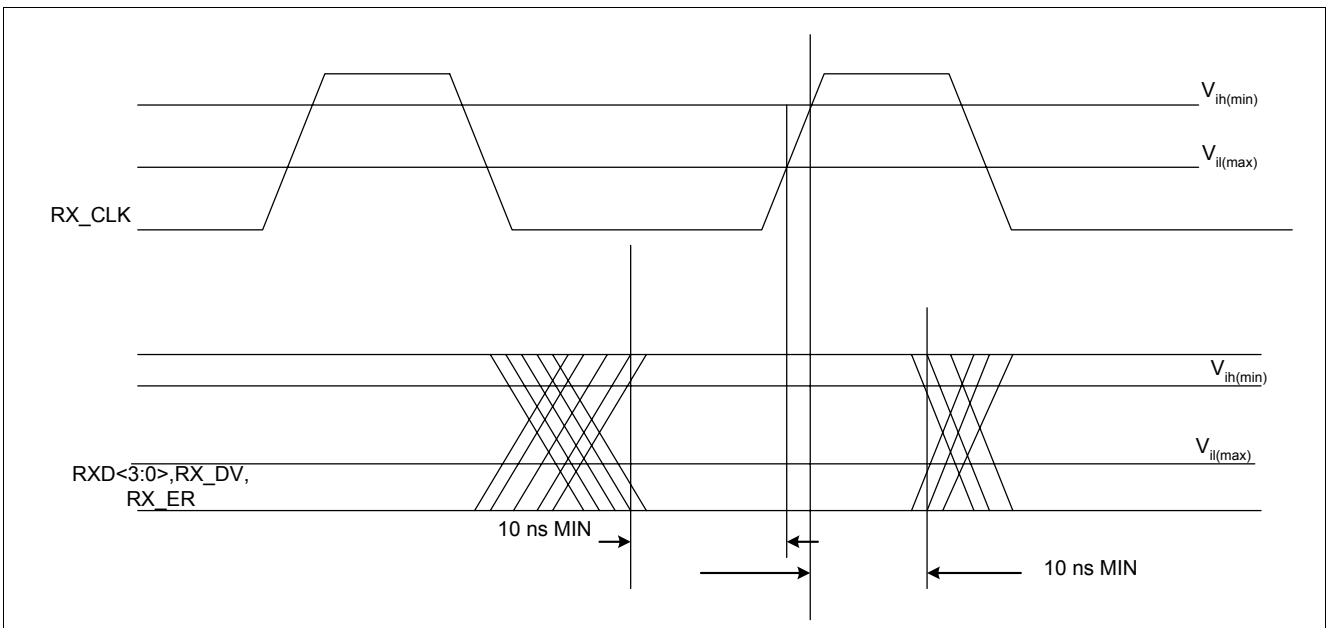

Figure 22 Receive Signal Timing Relations at the MII

Electrical Specifications and Timings

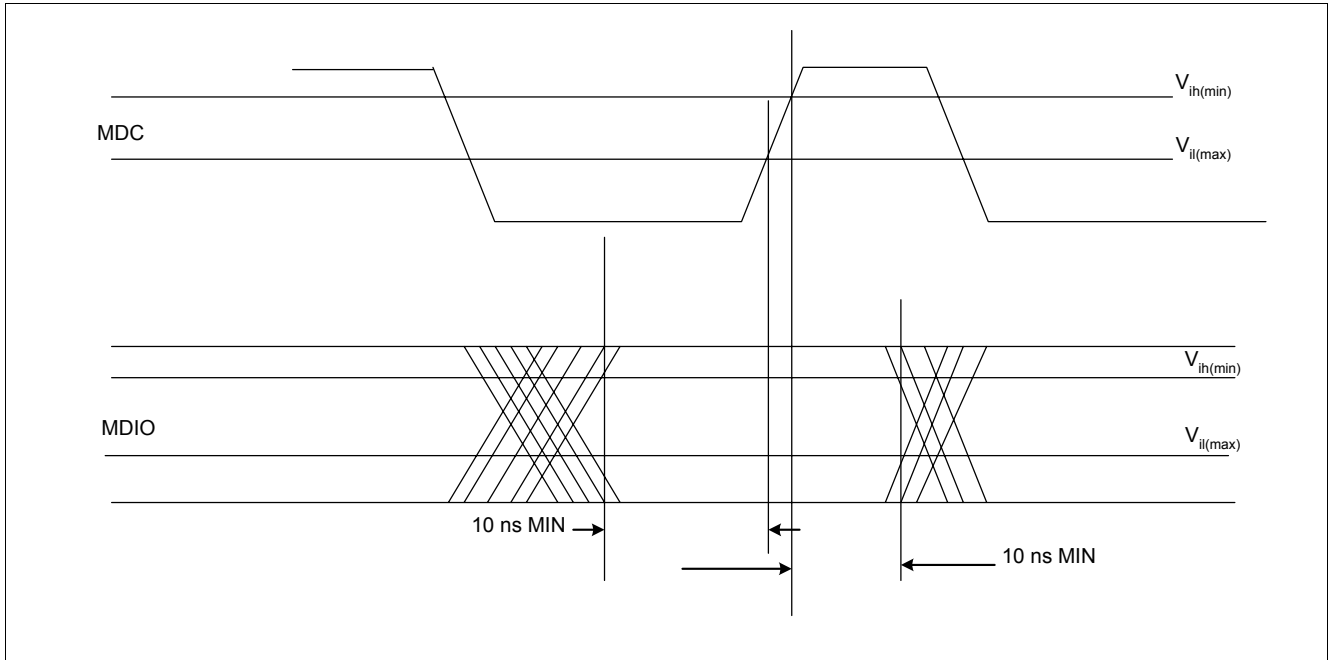

Figure 23 MDIO Sourced by STA

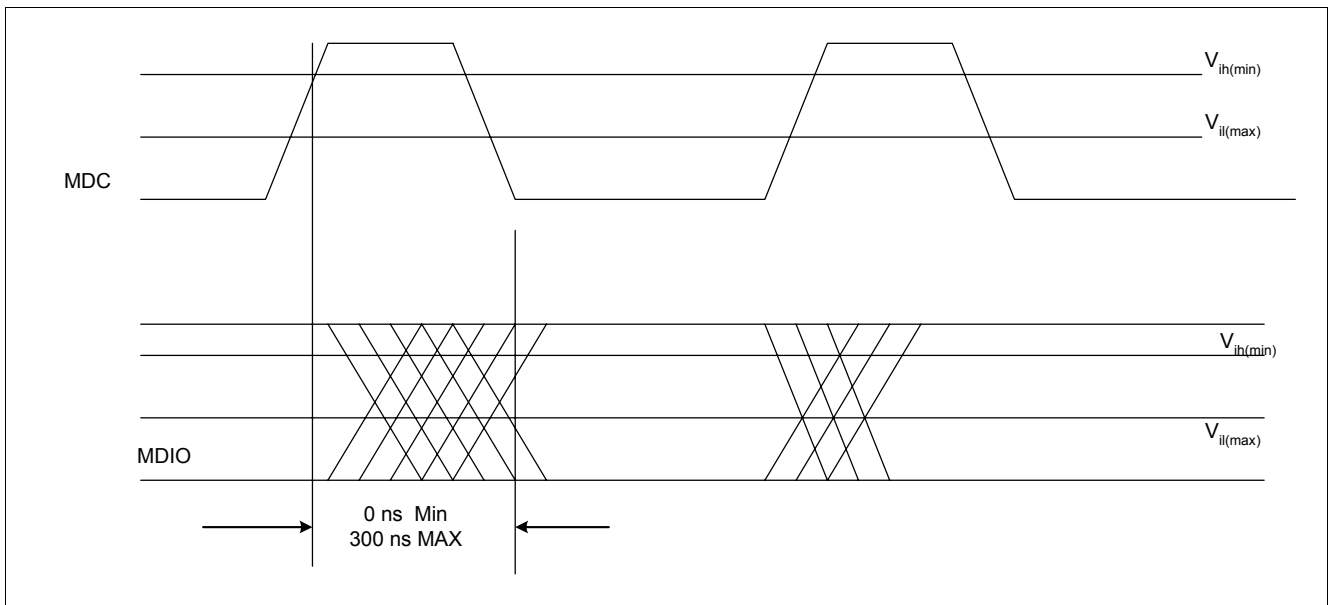

Figure 24 MDIO Sourced by PHY

# 11 Package Outlines

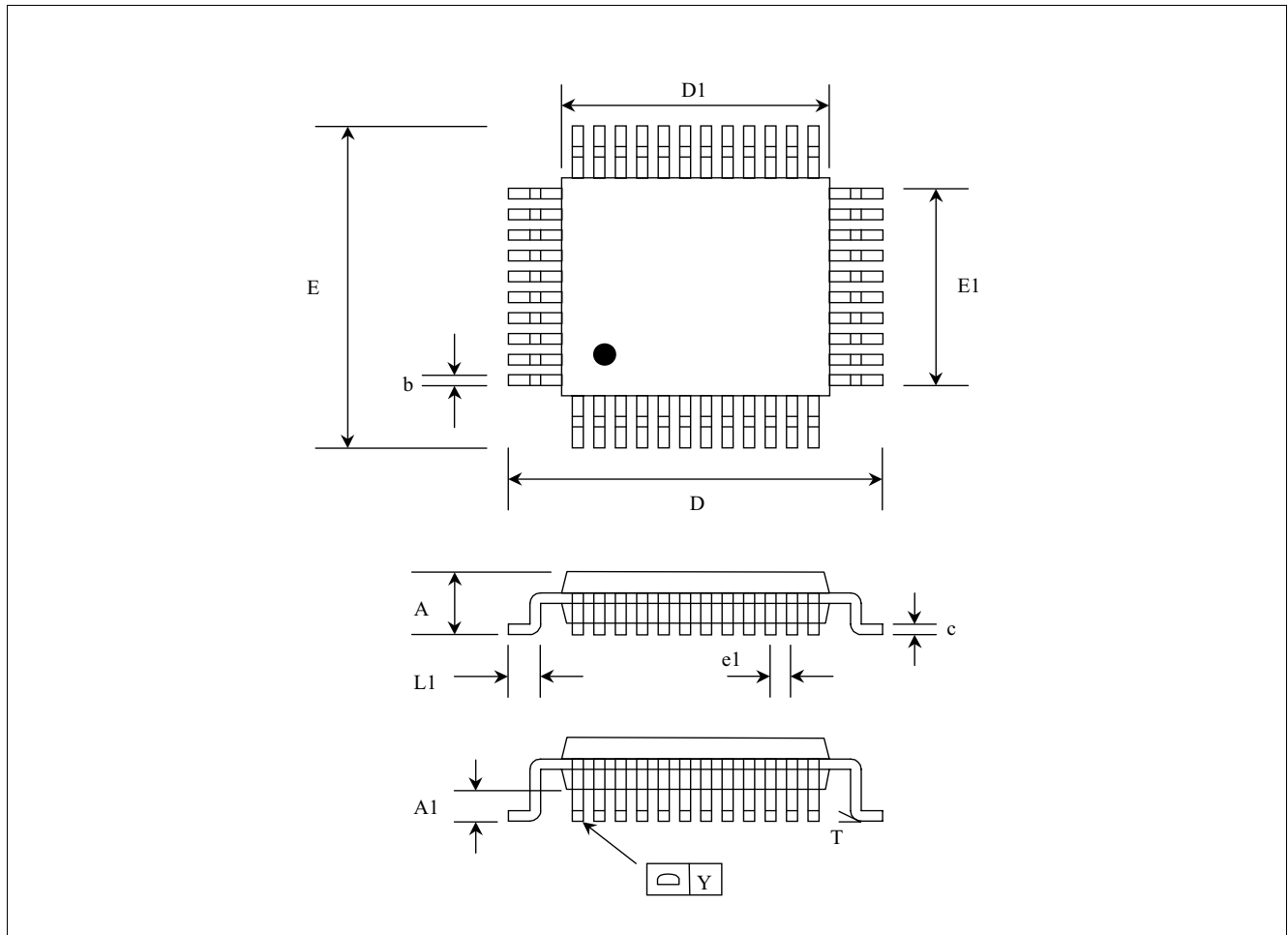

Figure 25 Package outline for the AN983B / AN983BL

Table 31 Dimensions for 128 -pin PQFP Package (AN983B/X)

Symbol	Description	Minimum	Maximum
A	Overall Height	-	3.4mm
A1	Stand Off	0.25mm	-
b	Lead Width	0.17mm	0.27mm
c	Lead Thickness	0.13mm	0.23mm
D	Terminal Dimension 1	23.0mm	23.4mm
D1	Package Body 1	19.9mm	20.1mm
E	Terminal Dimension 2	17.0mm	17.4mm
E1	Package Body 2	13.9mm	14.1mm
e1	Lead Pitch	0.50mm	-
L1	Foot Length	0.65mm	0.95mm
T	Lead Angle	0 degree	7 degree
Y	Coplanarity	-	0.076mm

**Table 32 Dimensions for 128 -pin LQFP Package (AN983BLX)**

<b>Symbol</b>	<b>Description</b>	<b>Minimum</b>	<b>Maximum</b>
A	Overall Height	-	1.6mm
A1	Stand Off	0.05mm	0.15mm
b	Lead Width	0.17mm	0.27mm
c	Lead Thickness	0.13mm	0.23mm
D	Terminal Dimension 1	21.9mm	22.1mm
D1	Package Body 1	19.9mm	20.1mm
E	Terminal Dimension 2	15.9mm	16.1mm
E1	Package Body 2	13.9mm	14.1mm
e1	Lead Pitch	0.50mm	-
L1	Foot Length	0.45mm	0.75mm
T	Lead Angle	0	7
Y	Coplanarity	-	0.076mm



## 12 Layout Guide (Rev. 1.0B)

**Table 33** Layout Guide Revision History

Revision Date	Revision	Description
October, 2000	1.0b	Add Item 2-d to reduce receive CRC error.

### 12.1 Placement

- Keep the distance as short as possible between Centaur-P and transformer, as well as transformer and RJ45.
- Make crystal device cross to Centaur-P pin x1 x2, and away from the following item:
  - Tx+/- Rx+/- differential pairs
  - PCB edge
  - Transformer
  - Any other high frequency items and associated traces
- Tx pull high resistor needs to close to chip and Rx receiving termination resistor and cap needs to close to transformer.
- De-couple cap should be placed as close to chip as possible. The traces should be short.
- Use ample dc-coupling and bulk capacitors to minimize noise.
- Use X7R ceramic capacitor for better capacitive characteristics overtemperature.

### 12.2 Trace Routing

- Arrangement Tx and Rx trace
  - Tx+/- and Rx+/- trace avoid right angle signal trace, suggest round angle >90°
  - Trace width must be wide that should be 2X layout program minimum request or wide than 8 mils.
  - Signal trace length between Tx+/- differential pairs should be cross to equal length the total should no long to 2 cm.same require apply to Rx+/-.
  - Make Tx and Rx trace route at the same signal plane and had better not using bias.
  - Every differential pairs as cross as possible, but no less then 8 mils and the space should be almost equal.
  - Keep the distance between the Tx and Rx differential pairs large, even separate ground planes underneath Tx and Rx signal pairs.
  - Away from clock and power trace.
  - If possible, with GND plane around.
  - If Tx rout trace must cross, you can swap the trace between chip and transformer, and transformer to RJ45, too.
  - The high frequency signal trace width 10~12mil.
  - PCI clk signal trace length must equal 2.5inch and other PCI bus signal trace length should less then 1.5 inch
- Digital signal should be away from analog signal and power trace. If it can't be avoided, better be cross over by 90 degree with analog/ $V_{CC}$  routing at other plane.
- $V_{CC}$  trace should short and prefer route in the format of the plane a special for GND.
- Connect Pin 8 and pin 14 together first then use signal via to Gnd.

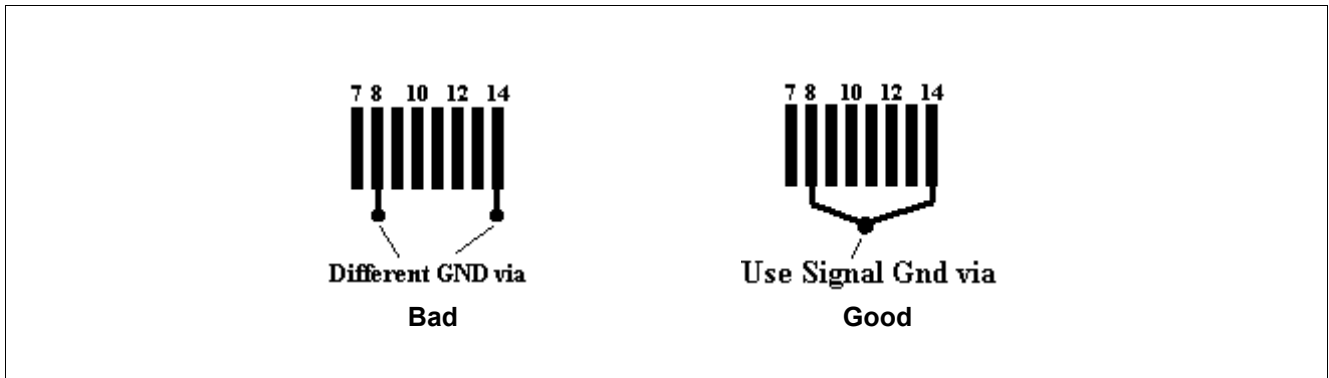

**Figure 26** Ground Via Trace Arrangement

### 12.3 $V_{CC}$ and GND

- $V_{CC}$  power
  - Avoid unnecessary  $V_{CC}$  trace to IC's and devices keep these traces as short and wide.
  - Power trace width > 40 mils (if power trace route to the other side, it must use several via to connect each other).
  - Power source use bulk capacitors (22~47  $\mu$ f) to reduce noise.
  - Provide sample power and ground planes

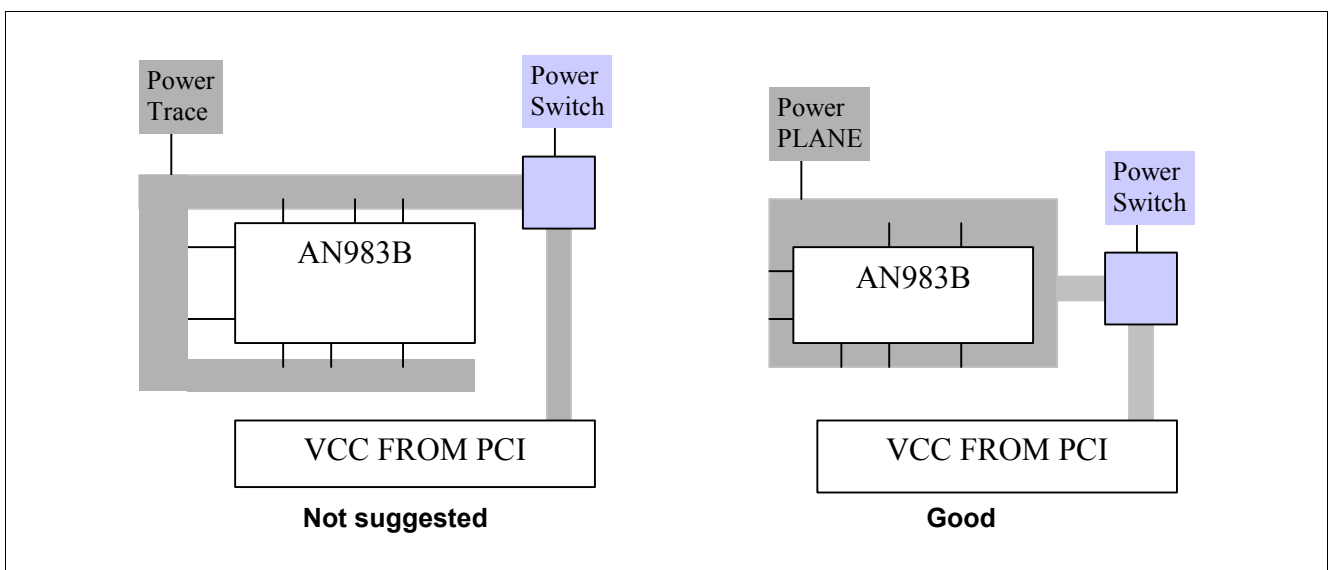

**Figure 27** Power Trace Arrangement

- GND plane
  - It is a good idea to fill in unused areas of the signal planes with solid copper.
  - The signal ground region should be one continuous, unbroken plane extending from the transformer through the rest of the board.
  - On right angle is recommend when partition the  $V_{CC}$  and GND plane.
  - For EMI consideration, please add 0.1  $\mu$ f caps between system GND and chassis GND.
  - Void the power and ground plane directly under the transformer.
  - The isolation voltage of the transformer should be rated to be greater than 2 kV.
  - The sample board  $V_{CC}$  and GND plane at below side.

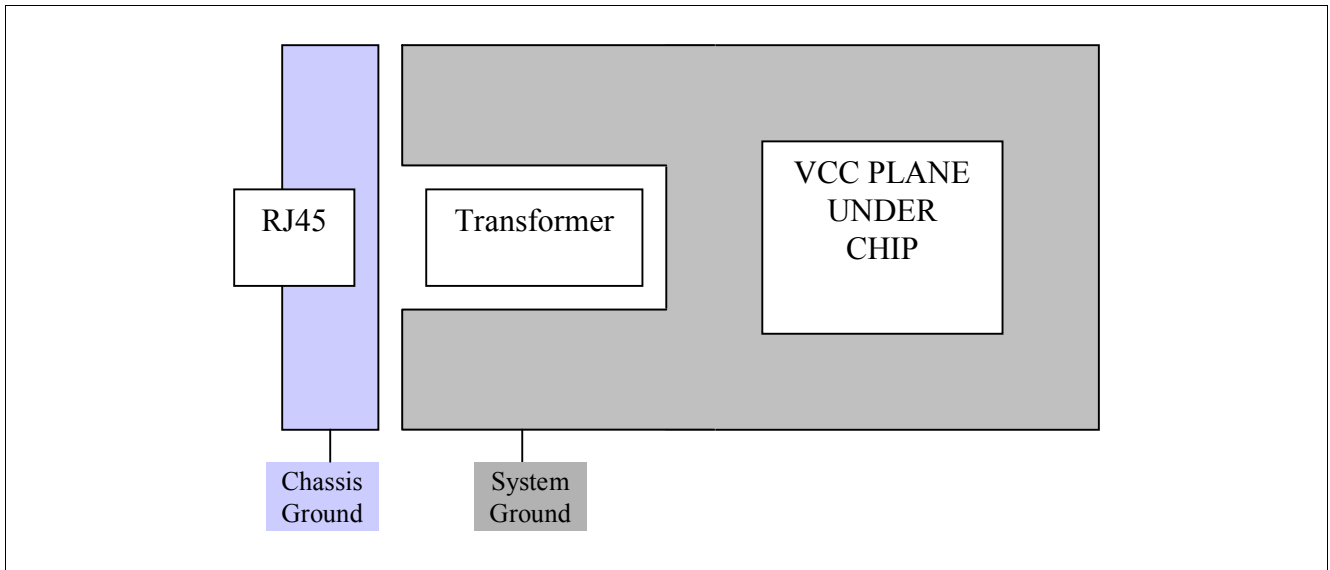

Figure 28 Ground Plane Arrangement

[www.infineon.com](http://www.infineon.com)

Published by Infineon Technologies AG

Downloaded From [Oneyac.com](http://Oneyac.com)

单击下面可查看定价，库存，交付和生命周期等信息

[>>Infineon\(英飞凌\)](#)