

International
IR Rectifier

Integrated Power Hybrid IC for
Low Voltage Motor Applications

IRAM136-3023B

iMOTION™ Series

30A, 150V

with Internal Shunt Resistor

Description

International Rectifier's IRAM136-3023B is a 30A, 150V Integrated Power Hybrid IC with Internal Shunt Resistor for low voltage Motor Drives applications such as electric vehicles, portable power tools and light industrial applications. IR's technology offers an extremely compact, high performance AC motor-driver in a single isolated package to simplify design.

This advanced HIC is a combination of IR's low $R_{DS(on)}$ Advance Planar MOSFET Super Rugged technology and the industry benchmark 3-Phase high voltage, high speed driver in a fully isolated thermally enhanced package. A built-in temperature monitor and over-current and over-temperature protections and integrated under-voltage lockout function, deliver high level of protection and fail-safe operation. Using a new developed single in line package (SiP3) with heat spreader for the power die along with full transfer mold structure minimizes PCB space and resolves isolation problems to heatsink.

Features

- Integrated Gate Drivers
- Temperature Monitor and Protection
- Overcurrent shutdown
- Low $R_{DS(on)}$ Advance Planar Super Rugged Technology
- Undervoltage lockout for all channels
- Matched propagation delay for all channels
- 5V Schmitt-triggered input logic
- Cross-conduction prevention logic
- Motor Power up to 4.0kW / 48~100 Vdc
- Fully Isolated Package, Isolation 2000V_{RMS} min
- RoHS Compliant
- Recognized by UL (File Number: E252584)

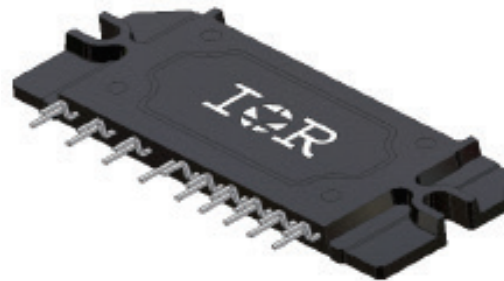

Absolute Maximum Ratings

Parameter	Description	Value	Units
$V_{BR(DSS)}$	MOSFET Blocking Voltage	150	V
V^+	Positive Bus Input Voltage	100	
$I_O @ T_C=25^\circ\text{C}$	RMS Phase Current (Note 1)	30	A
$I_O @ T_C=100^\circ\text{C}$	RMS Phase Current (Note 1)	15	
I_O	Pulsed RMS Phase Current (Note 1 and 2)	56	
F_{PWM}	PWM Carrier Frequency	20	kHz
P_D	Power Dissipation per MOSFET @ $T_C = 25^\circ\text{C}$	89	W
V_{ISO}	Isolation Voltage (1min)	2000	V _{RMS}
T_J (MOSFET & IC)	Maximum Operating Junction Temperature	+150	°C
T_C	Operating Case Temperature Range	-20 to +100	
T_{STG}	Storage Temperature Range	-40 to +125	
T	Mounting Torque (M4 screw)	0.7 to 1.17	Nm

Note 1: Sinusoidal modulation at $V^+=100\text{V}$, $T_J=150^\circ\text{C}$, $F_{PWM}=20\text{kHz}$, modulation depth=0.8, pf=0.6, see Figure 3

Note 2: $t_p < 100\text{ms}$; $T_C=25^\circ\text{C}$; $F_{PWM}=20\text{kHz}$, limited by $I_{BUS-TRIP}$, see Table "Inverter Section Electrical Characteristics"

IRAM136-3023B

Internal Electrical Schematic – IRAM136-3023B

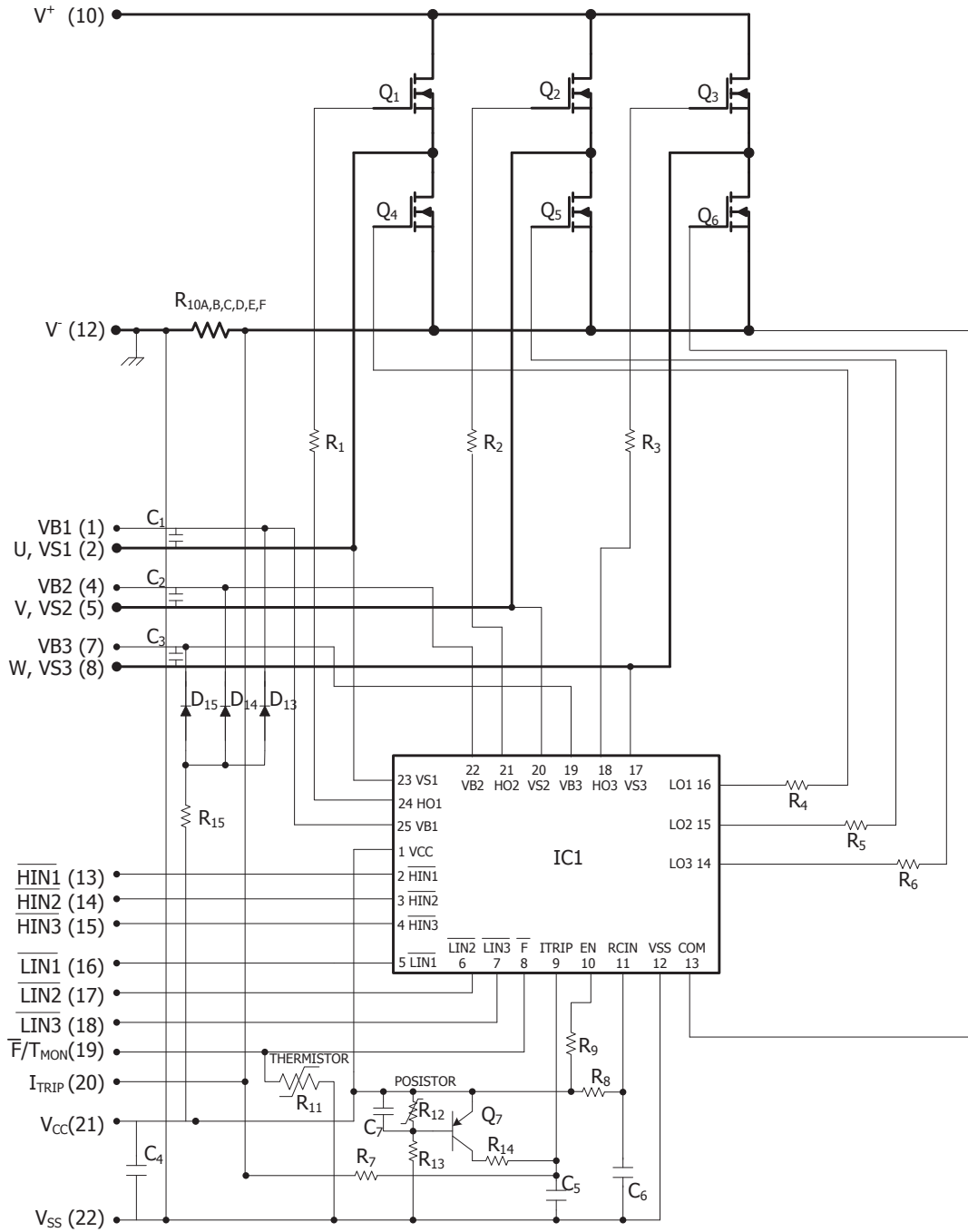

Absolute Maximum Ratings (Continued)

Symbol	Parameter	Min	Max	Units	Conditions
I_{BDF}	Bootstrap Diode Peak Forward Current	---	4.5	A	$t_p = 10\text{ms}$, $T_j = 150^\circ\text{C}$, $T_c = 100^\circ\text{C}$
$P_{BR \text{ Peak}}$	Bootstrap Resistor Peak Power (Single Pulse)	---	25.0	W	$t_p = 100\mu\text{s}$, $T_c = 100^\circ\text{C}$
$V_{S1,2,3}$	High side floating supply offset voltage	$V_{B1,2,3} - 25$	$V_{B1,2,3} + 0.3$	V	
$V_{B1,2,3}$	High side floating supply voltage	-0.3	150	V	
V_{CC}	Low Side and logic fixed supply voltage	-0.3	20	V	
V_{IN}	Input voltage LIN, HIN, I_{Trip}	-0.3	Lower of ($V_{SS} + 15\text{V}$) or $V_{CC} + 0.3\text{V}$	V	

Inverter Section Electrical Characteristics @ $T_j = 25^\circ\text{C}$

Symbol	Parameter	Min	Typ	Max	Units	Conditions
$V_{(BR)DSS}$	Drain-to-Source Breakdown Voltage	150	---	---	V	$V_{IN} = 5\text{V}$, $I_D = 250\mu\text{A}$
$\Delta V_{(BR)DSS} / \Delta T$	Temperature Coeff. Of Breakdown Voltage	---	0.16	---	V/ $^\circ\text{C}$	$V_{IN} = 5\text{V}$, $I_D = 1.0\text{mA}$ ($25^\circ\text{C} - 150^\circ\text{C}$)
$R_{DS(ON)}$	Drain-to-Source On Resistance	---	38	80	m Ω	$I_D = 15\text{A}$, $V_{CC} = 15\text{V}$
		---	65	122		$I_D = 15\text{A}$, $V_{CC} = 15\text{V}$, $T_j = 125^\circ\text{C}$
I_{DSS}	Zero Gate Voltage Drain Current	---	3	80	μA	$V_{IN} = 5\text{V}$, $V^+ = 150\text{V}$
		---	8	---		$V_{IN} = 5\text{V}$, $V^+ = 150\text{V}$, $T_j = 125^\circ\text{C}$
V_{SD}	Body Diode Forward Voltage Drop	---	1.2	1.9	V	$I_D = 15\text{A}$
		---	1.0	1.8		$I_D = 15\text{A}$, $T_j = 125^\circ\text{C}$
V_{BDFM}	Bootstrap Diode Forward Voltage Drop	--	--	1.25	V	$I_F = 1\text{A}$
		---	---	1.10		$I_F = 1\text{A}$, $T_j = 125^\circ\text{C}$
R_{BR}	Bootstrap Resistor Value	---	22	---	Ω	$T_j = 25^\circ\text{C}$
$\Delta R_{BR}/R_{BR}$	Bootstrap Resistor Tolerance	---	---	± 5	%	$T_j = 25^\circ\text{C}$
I_{BUS_TRIP}	Current Protection Threshold (positive going)	56	---	68	A	See Figure 2

Inverter Section Switching Characteristics @ $T_J = 25^\circ\text{C}$

Symbol	Parameter	Min	Typ	Max	Units	Conditions
E_{ON}	Turn-On Switching Loss ^{1/}	---	395	1100	μJ	$I_D = 15\text{A}$, $V^+ = 100\text{V}$ $V_{CC} = 15\text{V}$, $L = 2\text{mH}$ Energy losses include "tail" and diode reverse recovery See CT1
E_{OFF}	Turn-Off Switching Loss ^{1/}	---	135	250		
E_{TOT}	Total Switching Loss ^{1/}	---	530	1350		
E_{REC}	Diode Reverse Recovery energy ^{1/}	---	210	1000		
t_{RR}	Diode Reverse Recovery time ^{1/}	---	240	---	ns	See CT1
E_{ON}	Turn-on Switching Loss ^{1/}	---	360	970	μJ	$I_D = 15\text{A}$, $V^+ = 100\text{V}$ $V_{CC} = 15\text{V}$, $L = 2\text{mH}$, $T_J = 125^\circ\text{C}$ Energy losses include "tail" and diode reverse recovery See CT1
E_{OFF}	Turn-off Switching Loss ^{1/}	---	115	210		
E_{TOT}	Total Switching Loss ^{1/}	---	475	1180		
E_{REC}	Diode Reverse Recovery energy ^{1/}	---	230	1000		
t_{RR}	Diode Reverse Recovery time ^{1/}	---	270	---	ns	See CT1
Q_G	Turn-On FET Gate Charge ^{1/}	---	60	89	nC	$I_D = 36\text{A}$, $V^+ = 75\text{V}$, $V_{GS} = 10\text{V}$
E_{AS}	Single Pulse Avalanche Energy	---	---	470	mJ	Note 3, 4
I_{AR}	Avalanche Current	---	---	36	A	Repetitive rating; pulse width limited by max. junction temperature. (Note 4)
E_{AR}	Repetitive Avalanche Energy	---	---	32	mJ	

Note 3: Starting $T_J = 25^\circ\text{C}$, $L = 0.72\text{mH}$, $R_G = 25\Omega$, $I_{AS} = 36\text{A}$

Note 4: This is only applied to TO-220AB package

^{1/} Based on Characterization Data only. Not subject to production test.

Recommended Operating Conditions Driver Function

The Input/Output logic timing diagram is shown in Figure 1. For proper operation the device should be used within the recommended conditions. All voltages are absolute referenced to COM/ I_{TRIP} . The V_S offset is tested with all supplies biased at 15V differential (Note 5).

Symbol	Definition	Min	Max	Units
$V_{B1,2,3}$	High side floating supply voltage	$V_S + 10$	$V_S + 20$	V
$V_{S1,2,3}$	High side floating supply offset voltage	Note 6	150	
V_{CC}	Low side and logic fixed supply voltage	12	20	V
V_{IN}	Logic input voltage LIN, HIN	V_{SS}	$V_{SS} + 5$	V

Note 5: For more details, see IR2136 data sheet

Note 6: Logic operational for V_S from COM-5V to COM+150V. Logic state held for V_S from COM-5V to COM- V_{BS} . (please refer to DT97-3 for more details)

Static Electrical Characteristics Driver Function @ T_j= 25°C

V_{BIAS} (V_{CC}, V_{BS1,2,3})=15V, unless otherwise specified. The V_{IN} and I_{IN} parameters are referenced to V_{SS} and are applicable to all six channels (Static Electrical Characteristics are Based on Driver IC Data Sheet, Note 5).

Symbol	Definition	Min	Typ	Max	Units
V _{IH}	Logic "0" input voltage	3.0	---	---	V
V _{IL}	Logic "1" input voltage	---	---	0.8	V
V _{CCUV+} , V _{BSUV+}	V _{CC} and V _{BS} supply undervoltage positive going threshold	8.0	8.9	9.8	V
V _{CCUV-} , V _{BSUV-}	V _{CC} and V _{BS} supply undervoltage negative going threshold	7.4	8.2	9.0	V
V _{CCUVH} , V _{BSUVH}	V _{CC} and V _{BS} supply undervoltage lock-out hysteresis	0.3	0.7	---	V
V _{IN,Clamp}	Input Clamp Voltage (HIN, LIN, T/I _{TRIP}) I _{IN} =10μA	4.9	5.2	5.5	V
I _{QBS}	Quiescent V _{BS} supply current V _{IN} =0V	---	---	165	μA
I _{QCC}	Quiescent V _{CC} supply current V _{IN} =0V	---	---	3.35	mA
I _{LK}	Offset Supply Leakage Current	---	---	60	μA
I _{IN+}	Input bias current V _{IN} =5V	---	200	300	μA
I _{IN-}	Input bias current V _{IN} =0V	---	100	220	μA
I _{TRIP+}	I _{TRIP} bias current V _{ITRIP} =5V	---	30	100	μA
I _{TRIP-}	I _{TRIP} bias current V _{ITRIP} =0V	---	0	1	μA
V(I _{TRIP})	I _{TRIP} threshold Voltage	440	490	540	mV
V(I _{TRIP} ,HYS)	I _{TRIP} Input Hysteresis	---	70	---	mV

Dynamic Electrical Characteristics @ T_j= 25°C

Symbol	Parameter	Min	Typ	Max	Units	Conditions
T _{ON}	Input to Output propagation turn-on delay time (see fig.11) ^{2/}	---	0.83	---	μs	V _{CC} =V _{BS} = 15V, I _D =30A, V ⁺ =100V
T _{OFF}	Input to Output propagation turn-off delay time (see fig. 11) ^{2/}	---	1.08	---	μs	
T _{FLIN}	Input Filter time (HIN, LIN) ^{3/}	100	200	---	ns	V _{IN} =0 & V _{IN} =5V
T _{BLT-Trip}	I _{TRIP} Blanking Time ^{3/}	100	150	---	ns	V _{IN} =0 & V _{IN} =5V
D _T	Dead Time (V _{BS} =V _{DD} =15V) ^{3/}	220	290	360	ns	V _{BS} =V _{CC} =15V
M _T	Matching Propagation Delay Time (On & Off) ^{3/}	---	40	75	ns	V _{CC} = V _{BS} = 15V, external dead time> 400ns
T _{ITrip}	I _{trip} to six switch to turn-off propagation delay (see fig. 2) ^{4/}	---	3.2	---	μs	V _{CC} =V _{BS} = 15V, I _D =30A, V ⁺ =100V
T _{FLT-CLR}	Post I _{trip} to six switch to turn-off clear time (see fig. 2) ^{4/}	---	7.7	---	ms	T _C = 25°C
		---	6.7	---		T _C = 100°C

^{2/} Based on Characterization Data only. Not subject to production test.

^{3/} Based on Driver IC Data Sheet.

^{4/} Verified by Design. Not subject to production test.

Thermal and Mechanical Characteristics

Symbol	Parameter	Min	Typ	Max	Units	Conditions
$R_{th(J-C)}$	Thermal resistance, FET ^{5/}	---	1.2	1.4	°C/W	Flat, greased surface. Heatsink compound thermal conductivity 1W/m²K
$R_{th(C-S)}$	Thermal resistance, C-S ^{5/}	---	0.1	---		
C_D	Creepage Distance	3.5	---	---	mm	See outline Drawings

^{5/} Based on Characterization Data only. Not subject to production test.

Internal Current Sensing Resistor - Shunt Characteristics

Symbol	Parameter	Min	Typ	Max	Units	Conditions
R_{Shunt}	Resistance	8.1	8.3	8.5	mΩ	$T_C = 25^\circ\text{C}$
T_{Coeff}	Temperature Coefficient	0	---	200	ppm/°C	
P_{Shunt}	Power Dissipation	---	---	4.5	W	$-40^\circ\text{C} < T_C < 100^\circ\text{C}$
T_{Range}	Temperature Range	-20	---	125	°C	

Internal NTC - Thermistor Characteristics

Parameter	Definition	Min	Typ	Max	Units	Conditions
R_{25}	Resistance	97	100	103	kΩ	$T_C = 25^\circ\text{C}$
R_{125}	Resistance ^{6/}	2.25	2.52	2.80	kΩ	$T_C = 125^\circ\text{C}$
B	B-constant (25-50°C) ^{6/}	4165	4250	4335	k	$R_2 = R_1 e^{[B(1/T_2 - 1/T_1)]}$
Temperature Range		-20	---	125	°C	
Typ. Dissipation constant		---	1	---	mW/°C	$T_C = 25^\circ\text{C}$

^{6/} Verified by Design. Not subject to production test.

Input-Output Logic Level Table

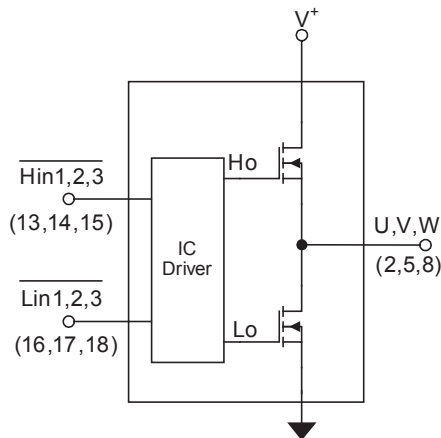

I_{TRIP}	$\overline{HIN1,2,3}$	$\overline{LIN1,2,3}$	U,V,W
0	0	1	V^+
0	1	0	0
0	1	1	X
1	X	X	X

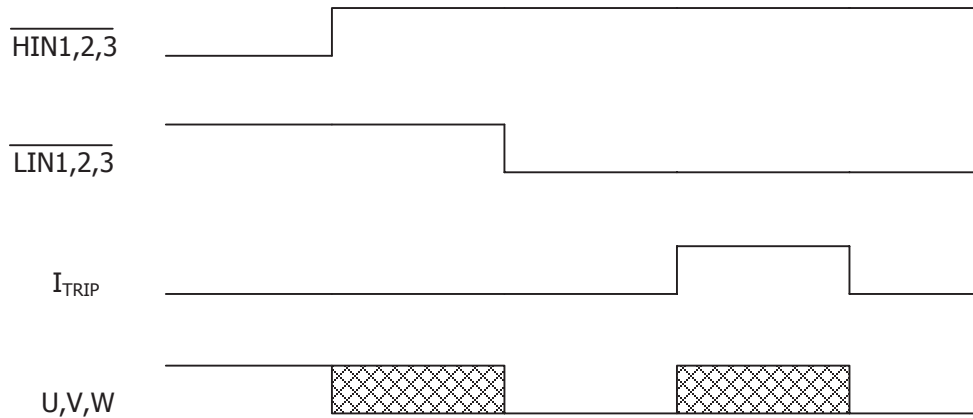

Figure 1. Input/Output Timing Diagram

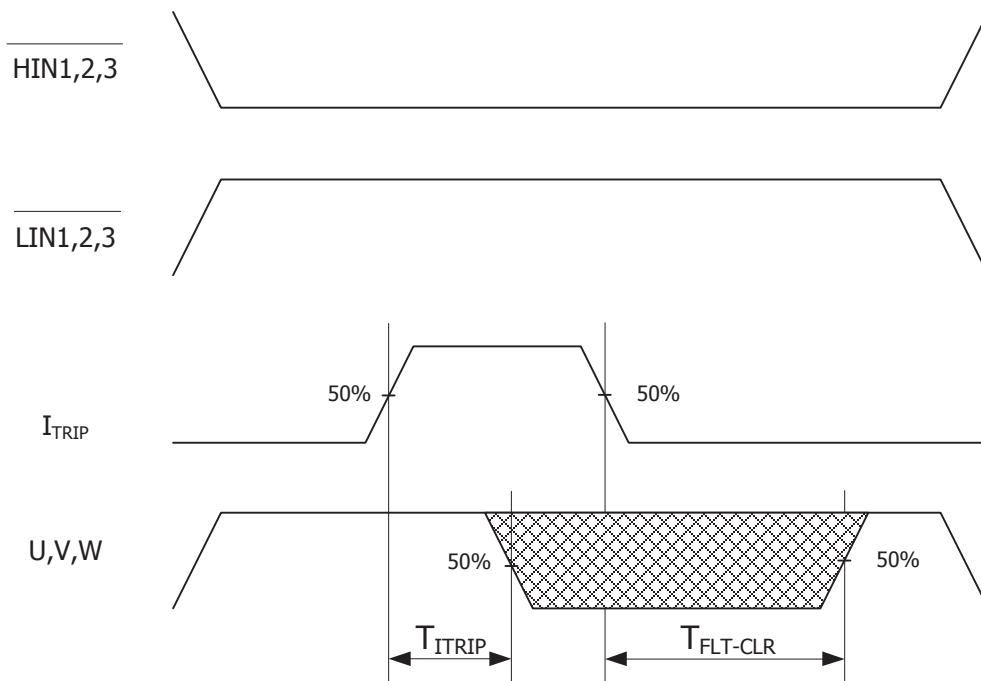
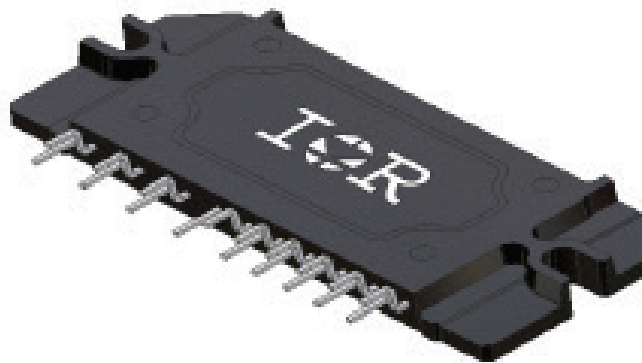

Figure 2. I_{TRIP} Timing Waveform

Note 7: The shaded area indicates that both high-side and low-side switches are off and therefore the half-bridge output voltage would be determined by the direction of current flow in the load.

Module Pin-Out Description

Pin	Name	Description
1	V_{B1}	High Side Floating Supply Voltage 1
2	U, V_{S1}	Output 1 - High Side Floating Supply Offset Voltage
3	NA	none
4	V_{B2}	High Side Floating Supply voltage 2
5	V, V_{S2}	Output 2 - High Side Floating Supply Offset Voltage
6	NA	none
7	V_{B3}	High Side Floating Supply voltage 3
8	W, V_{S3}	Output 3 - High Side Floating Supply Offset Voltage
9	NA	none
10	V^+	Positive Bus Input Voltage
11	NA	none
12	V^-	Negative Bus Input Voltage
13	\overline{H}_{IN1}	Logic Input High Side Gate Driver - Phase 1
14	\overline{H}_{IN2}	Logic Input High Side Gate Driver - Phase 2
15	\overline{H}_{IN3}	Logic Input High Side Gate Driver - Phase 3
16	\overline{L}_{IN1}	Logic Input Low Side Gate Driver - Phase 1
17	\overline{L}_{IN2}	Logic Input Low Side Gate Driver - Phase 2
18	\overline{L}_{IN3}	Logic Input Low Side Gate Driver - Phase 3
19	$\overline{\text{Fault/T}}_{MON}$	Temperature Monitor and Fault Function
20	I_{Sense}	Current Monitor
21	V_{CC}	+15V Main Supply
22	V_{SS}	Negative Main Supply



Typical Application Connection IRAM136-3023B

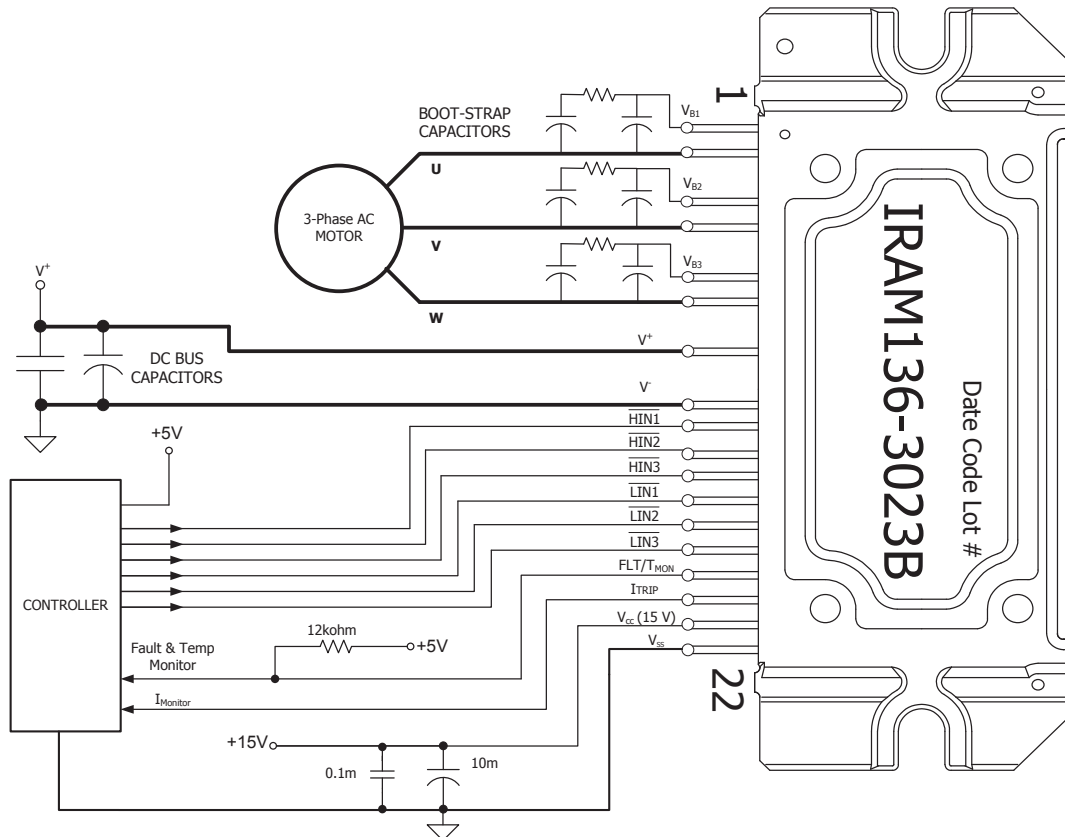

1. Electrolytic bus capacitors should be mounted as close to the module bus terminals as possible to reduce ringing and EMI problems. Additional high frequency ceramic capacitor mounted close to the module pins will further improve performance.
2. In order to provide good decoupling between VCC-VSS and VB1,2,3-VS1,2,3 terminals, the capacitors shown connected between these terminals should be located very close to the module pins. Additional high frequency capacitors, typically 0.1μF, are strongly recommended.
3. Value of the boot-strap capacitors depends upon the switching frequency. Their selection should be made based on IR design tip DN 98-2a, application note AN-1044 or Figure 9. Bootstrap capacitor value must be selected to limit the power dissipation of the internal resistor in series with the VCC. (see maximum ratings Table on page 3).
4. After approx. 8ms the FAULT is reset. (see Dynamic Characteristics Table on page 5).
5. PWM generator must be disabled within Fault duration to guarantee shutdown of the system, overcurrent condition must be cleared before resuming operation.
6. Fault/T_{MON} Monitor pin must be pulled-up to +5V.

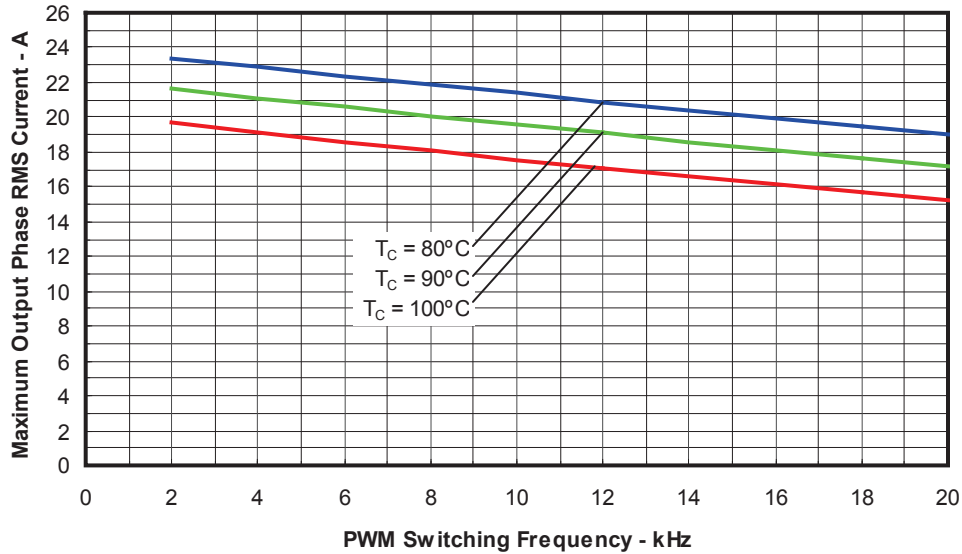

Figure 3. Maximum Sinusoidal Phase Current vs. PWM Switching Frequency
Sinusoidal Modulation, $V^+ = 100\text{V}$, $T_J = 150^\circ\text{C}$, Modulation Depth=0.8, PF=0.6

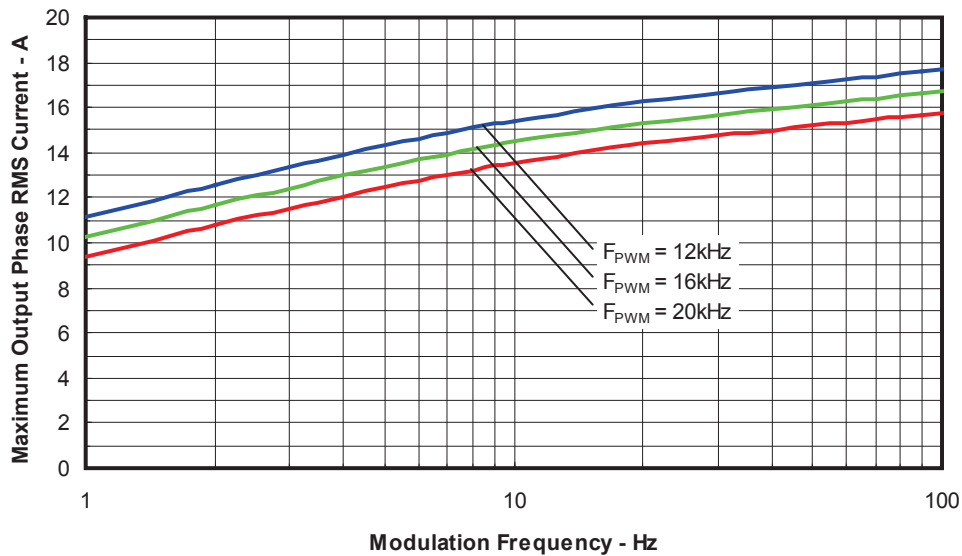

Figure 4. Maximum Sinusoidal Phase Current vs. Modulation Frequency
Sinusoidal Modulation, $V^+ = 100\text{V}$, $T_J = 100^\circ\text{C}$, Modulation Depth=0.8, PF=0.6

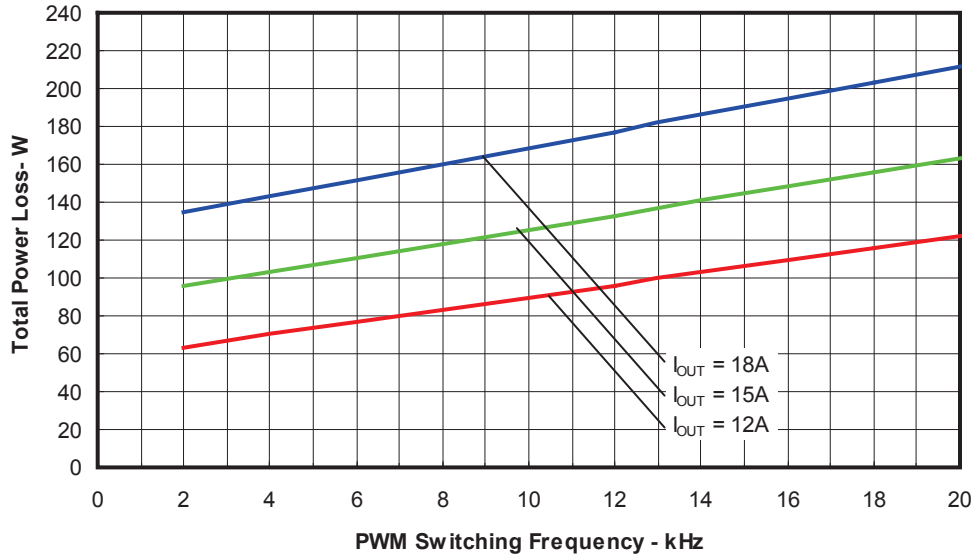

Figure 5. Total Power Losses vs. PWM Switching Frequency
Sinusoidal Modulation, $V^+ = 100V$, $T_J = 150^\circ C$, Modulation Depth=0.8, PF=0.6

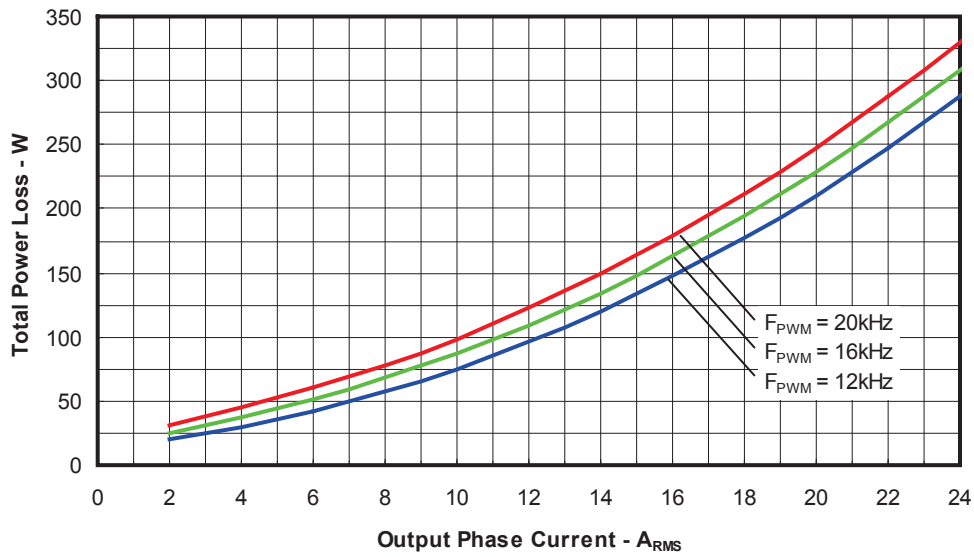

Figure 6. Total Power Losses vs. Output Phase Current
Sinusoidal Modulation, $V^+ = 100V$, $T_J = 150^\circ C$, Modulation Depth=0.8, PF=0.6

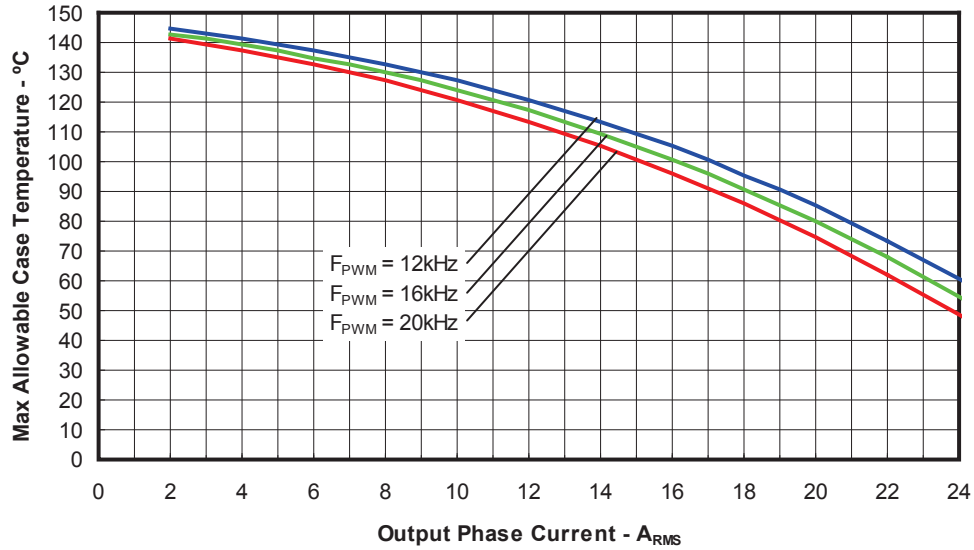

Figure 7. Maximum Allowable Case Temperature vs. Output RMS Current per Phase
Sinusoidal Modulation, $V^+ = 100V$, $T_J = 150^\circ C$, Modulation Depth=0.8, PF=0.6

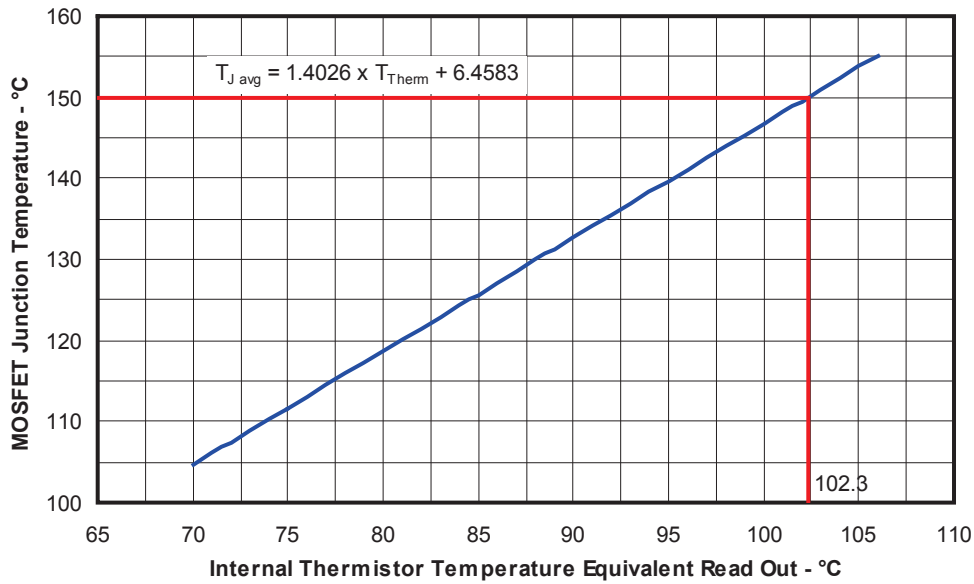

Figure 8. Estimated Maximum MOSFET Junction Temperature vs. Thermistor Temperature

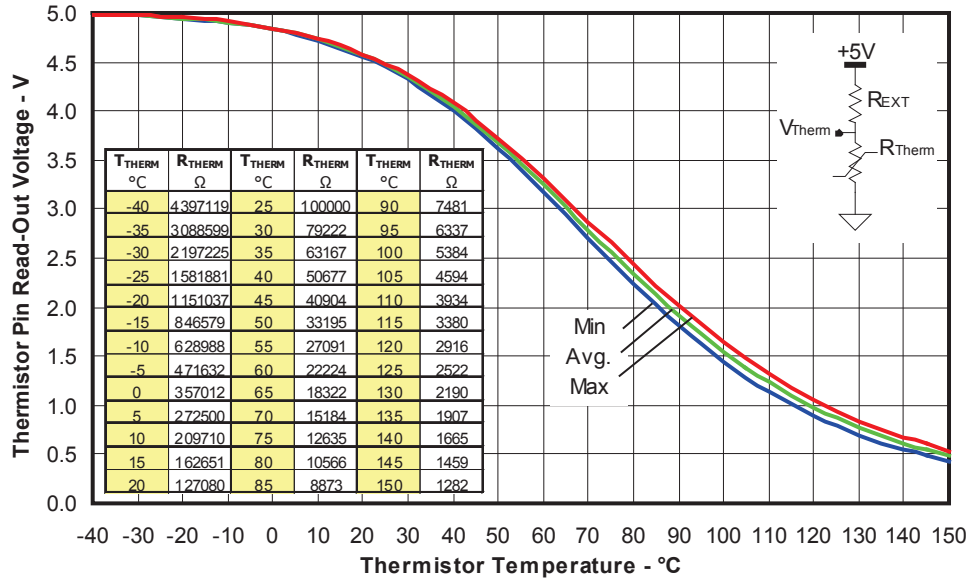

Figure 9. Thermistor Readout vs. Temperature (12Kohm pull-up resistor, 5V) and Normal Thermistor Resistance values vs. Temperature Table.

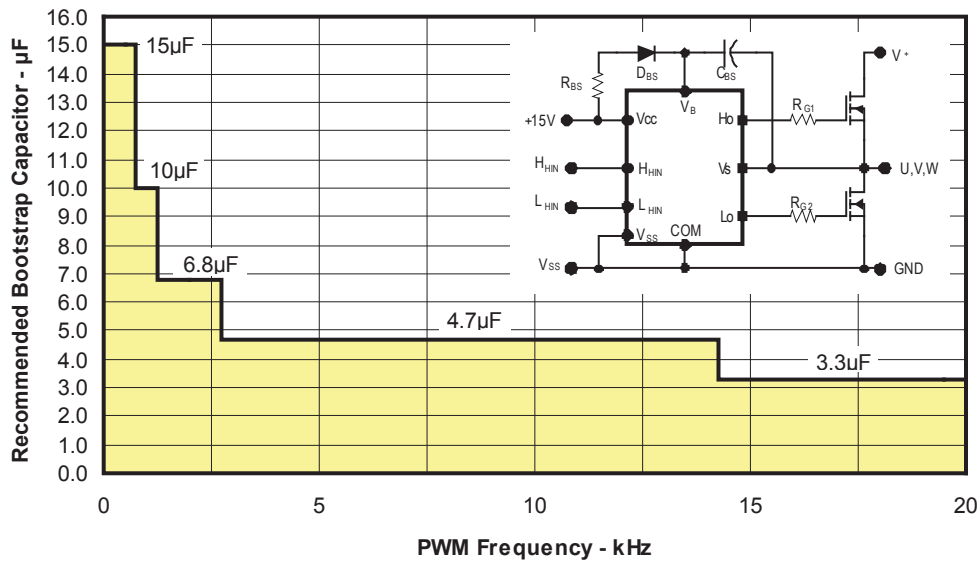

Figure 10. Recommended Bootstrap Capacitor Value vs. Switching Frequency

Figure 11. Switching Parameter Definitions

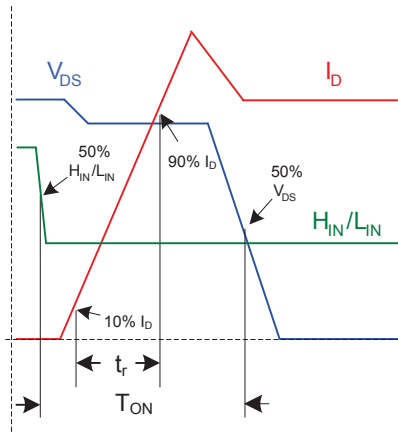

Figure 11a. Input to Output propagation turn-on delay time.

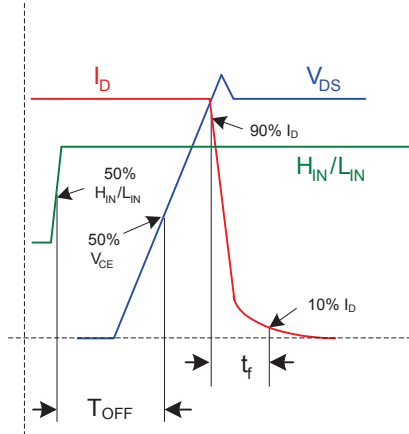

Figure 11b. Input to Output propagation turn-off delay time.

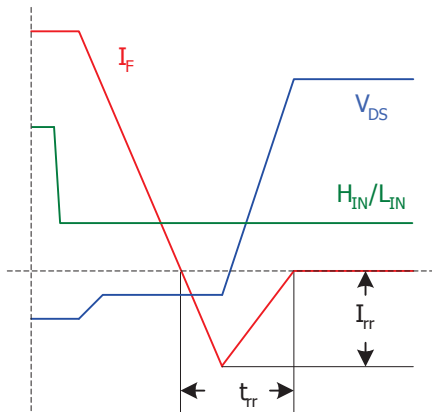

Figure 11c. Diode Reverse Recovery.

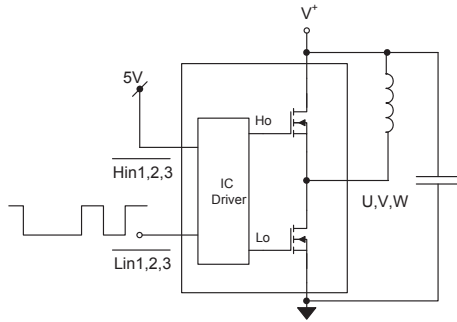

Figure CT1. Switching Loss Circuit

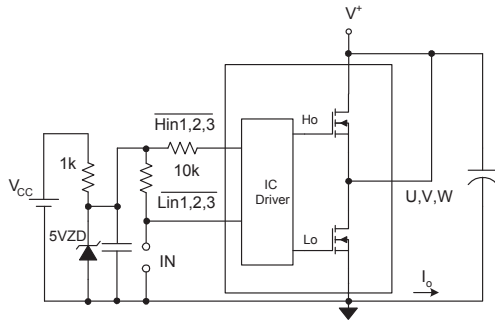
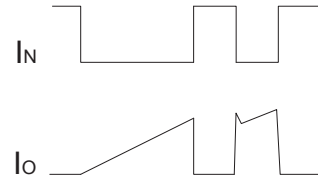

Figure CT2. S.C.SOA Circuit

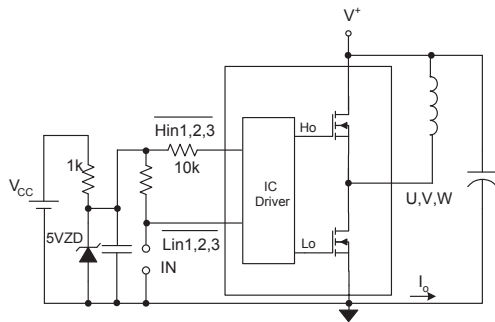
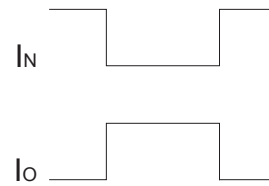
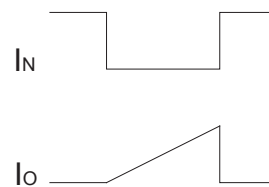

Figure CT3. R.B.SOA Circuit



IRAM136-3023B

Package Outline IRAM136-3023B

Missing Pin : 3,6,9,11

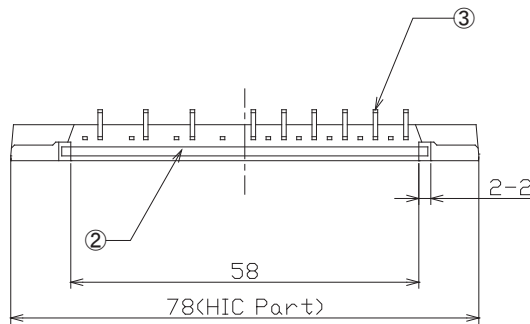
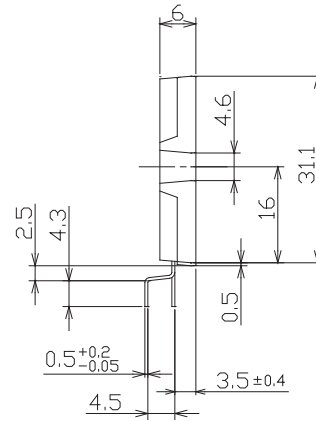
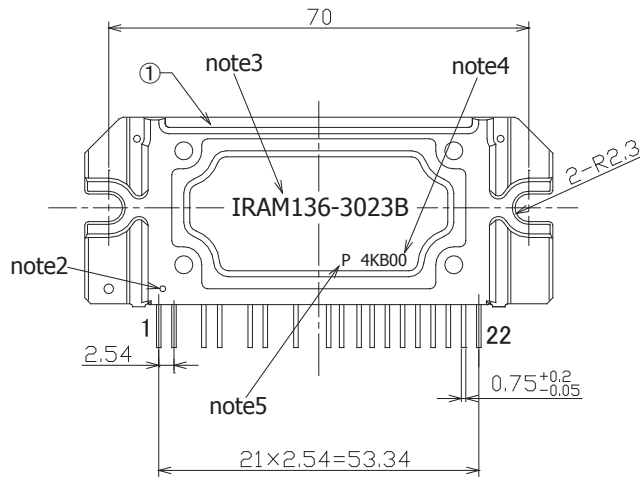

- note1: Unit Tolerance is ± 0.5 mm, Unless Otherwise Specified.
- note2: Mirror Surface Mark indicates Pin1 Identification.
- note3: Characters Font in this drawing differs from Font shown on Module.
- note4: Lot Code Marking. Characters Font in this drawing differs from Font shown on Module.
- note5: "P" Character denotes Lead Free. Characters Font in this drawing differs from Font shown on Module.

Dimensions in mm
 For mounting instruction see AN-1049

Package Outline IRAM136-3023B2

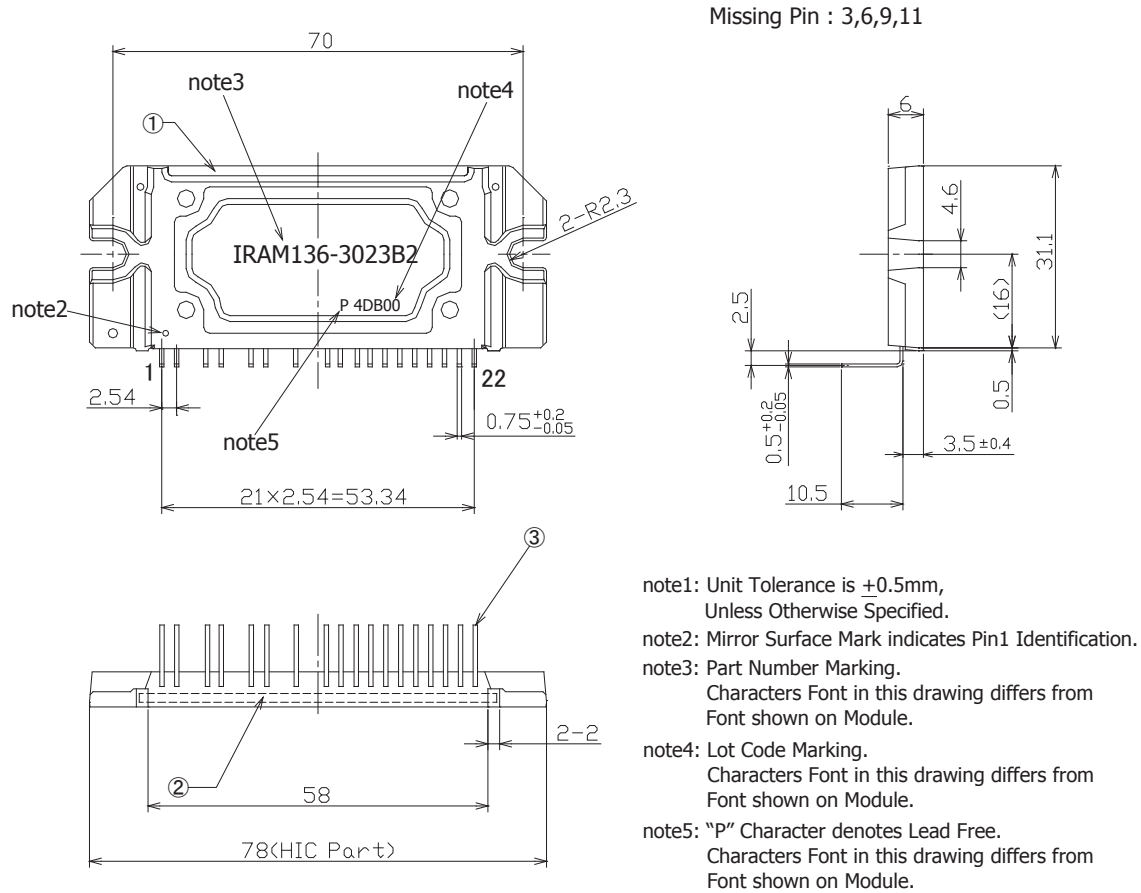

For mounting instruction see AN-1049

单击下面可查看定价，库存，交付和生命周期等信息

[>>Infineon\(英飞凌\)](#)