

Speed PROFET™

BTF50060-1TEA

Smart High-Side Power Switch, One Channel
High PWM Frequencies

Datasheet

Rev. 1.2, 2011-09-01

Automotive

1	Overview	3
2	Block Diagram	4
3	Pin Configuration	5
3.1	Pin Assignment	5
3.2	Pin Definitions and Functions	5
3.3	Definition of Terms	5
4	General Product Characteristics	6
4.1	Absolute Maximum Ratings	6
4.2	Functional Range	9
4.3	Thermal Resistance	10
5	Functional Description	12
5.1	Power Stage	12
5.1.1	Switching a Resistive Load	12
5.1.2	Switching an Inductive Load - Infineon® SMART CLAMPING	13
5.1.3	Switching a Capacitive Load	14
5.1.4	Inverse Load Current Operation	14
5.2	Input Circuit	14
5.3	Protection Functions	16
5.3.1	Protection by Over Current Shutdown	16
5.3.2	Protection by Over Temperature Shutdown	17
5.3.3	Infineon® INTELLIGENT LATCH	17
5.3.4	Reverse Polarity Protection	17
5.3.5	Protection during Loss of Ground	18
5.3.6	Protection during Loss of Load or Loss of V_S Condition	18
5.3.7	Protection during ESD or Over Voltage Condition	19
5.4	Diagnosis Functions	20
5.4.1	Sense Output	20
5.4.2	Enhancing Accuracy of the Sense Output by End of Line Calibration	22
5.4.3	Short-to-Battery detection / Open Load Detection in OFF state	22
5.5	Undervoltage Shutdown & Restart	23
6	Electrical Characteristics BTF50060-1TEA	24
6.1	Electrical Characteristics Table	24
6.2	Parameter dependencies	28
6.2.1	Power Stage	28
6.2.2	Input Circuit	30
6.2.3	Protection Functions	31
6.2.4	Diagnosis Functions	32
7	Application Information	34
7.1	Further Application Information	35
8	Package Outlines and Parameters	36
9	Revision History	37



1 Overview

Application

- Driving all types of resistive, inductive and capacitive loads
- Most suitable for driving loads with PWM frequency from 0Hz (DC operation) up to 33kHz and above
- Drives valves, coils, and motors, with inrush currents up to 60 A

Features

- Optimized for PWM frequencies of approx. 25 kHz
- 3.3V and 5V compatible logic inputs
- Advanced analog load current sense signal
- Designed for easy current sense calibration
- Embedded diagnosis features (e.g. open load in ON and OFF state)
- Embedded protection functions (e.g. over current shutdown, over temperature shutdown)
- Infineon® INTELLIGENT LATCH
- Infineon® SMART CLAMPING
- Green Product (RoHS compliant)
- AEC Qualified

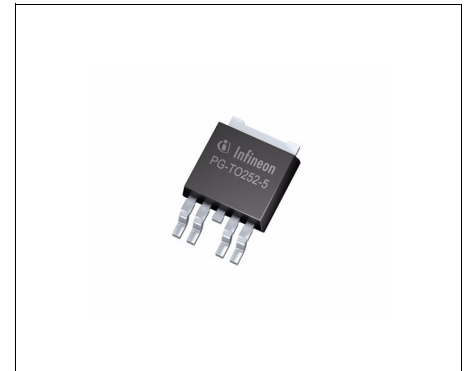

PG-TO252-5-11

Description

Embedded in a PG-TO252-5-11 package, the BTF50060-1TEA is a 6mΩ single channel Smart High-Side Power Switch. It is based on Smart power chip on chip technology with a P-channel vertical power MOSFET, providing protective and diagnostic functions. It is specially designed to drive loads in the harsh automotive environment.

Table 1 Product Summary

Parameter	Symbol	Values
Range of typical PWM frequencies	f_{PWM}	0 Hz ... 33 kHz
Maximum On-state Resistance at $T_j = 150\text{ °C}$	$R_{DS(ON)_150}$	12 mΩ
Nominal Supply Voltage Range for Operation	$V_{S(NOM)}$	6 V ... 19 V
Nominal Load Current (DC operation)	$I_{L(NOM)}$	16.5 A
Typical Stand-by Current at $T_j = 25\text{ °C}$	$I_{S(OFF)}$	5 μA
Minimum short circuit current shutdown threshold	$I_{L(SC)}$	60 A
Maximum reverse battery voltage	$-V_{S(REV)}$	16 V

Type	Package	Marking
BTF50060-1TEA	PG-TO252-5-11	F50060A

Embedded Protection Functions

- Infineon® INTELLIGENT LATCH - resettable latch resulting from protective switch OFF
- Over current protection by short-circuit shutdown
- Overload protection by over-temperature shutdown
- Infineon® SMART CLAMPING

Embedded Diagnosis Functions

- Advanced analog load current sense signal with defined positive offset current; enabling load diagnosis like Open Load in ON state, overload
- Providing defined fault signal
- Open Load detection in OFF state
- Short-to-battery detection

2 Block Diagram

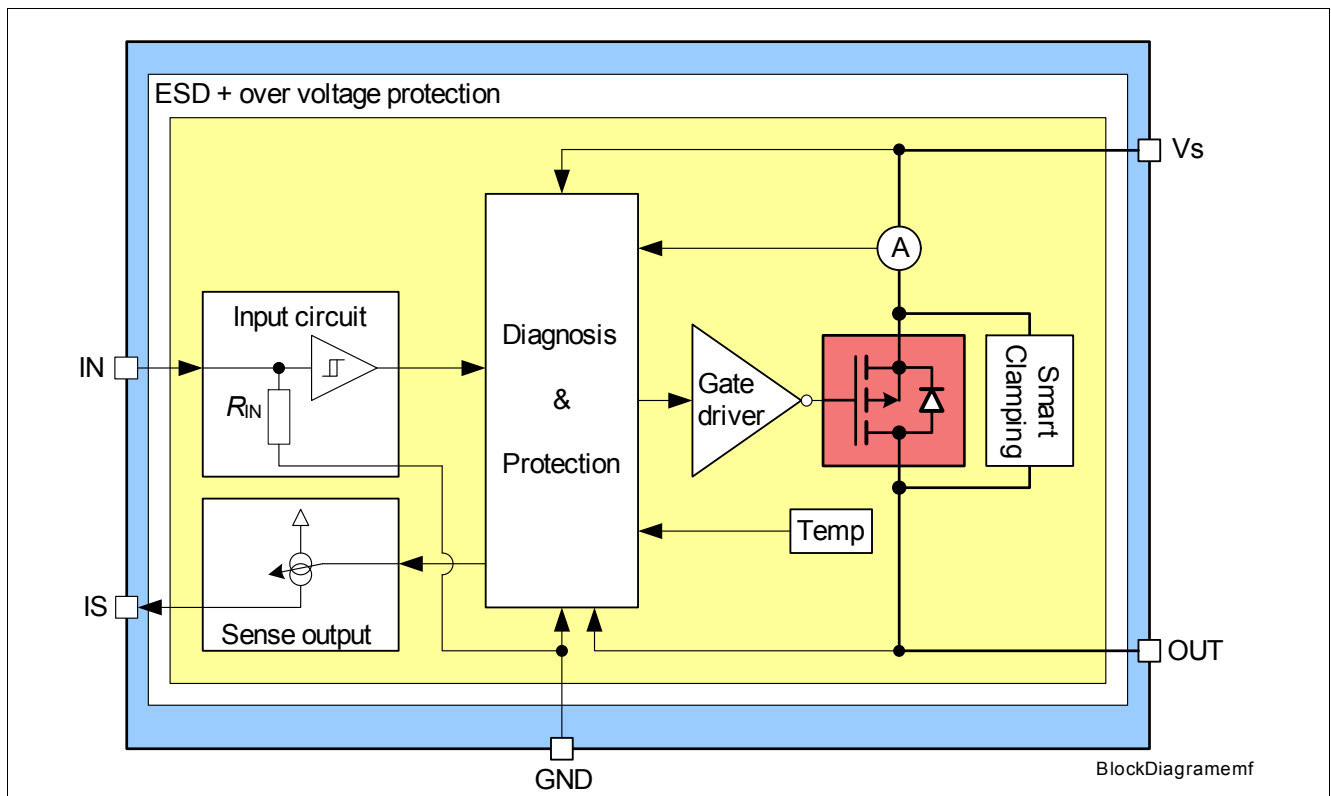

Figure 1 Block Diagram of BTF50060-1TEA

For a [Diagram of Diagnosis & Protection block](#), please see [Figure 15](#).

3 Pin Configuration

3.1 Pin Assignment

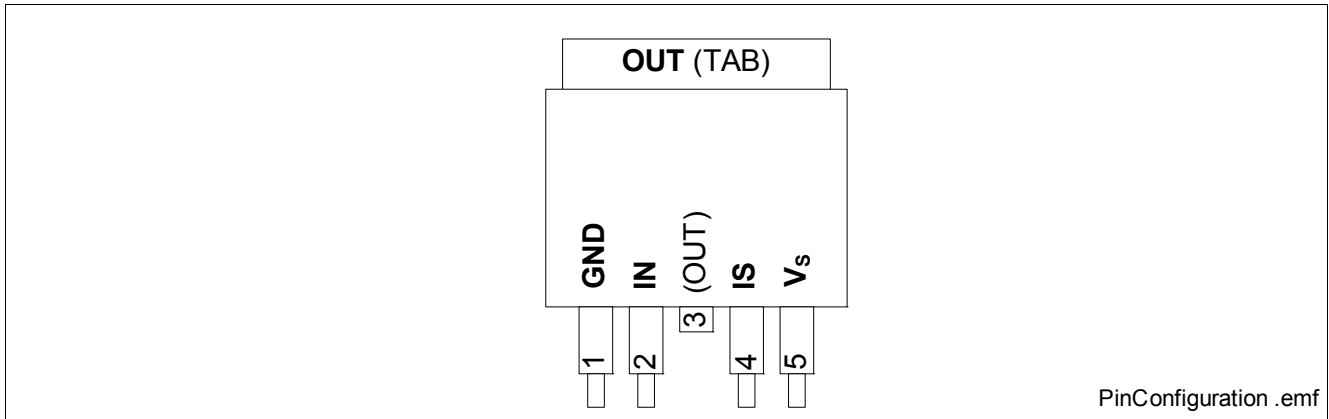

Figure 2 Pin Configuration

3.2 Pin Definitions and Functions

Pin	Symbol	Function
1	GND	Ground ; Ground connection for control chip.
2	IN	Input ; Digital 3.3 V and 5 V compatible logic input; activates power switch if set to HIGH level; Includes internal pull-down resistor R_{IN} .
Tab; 3 ¹⁾	OUT	Output ; Protected high side power output
4	IS	Sense ; Provides analog sense current signal and defined fault signal.
5	Vs	Supply Voltage ; Positive supply voltage for Logic and Power Stage ²⁾

1) Tab and pin 3 are internally connected. Pin 3 is cut.

2) PCB traces have to be designed to withstand maximum current occurring in the application.

3.3 Definition of Terms

Figure 3 shows all terms used for currents and voltages in this data sheet, with associated convention for positive values.

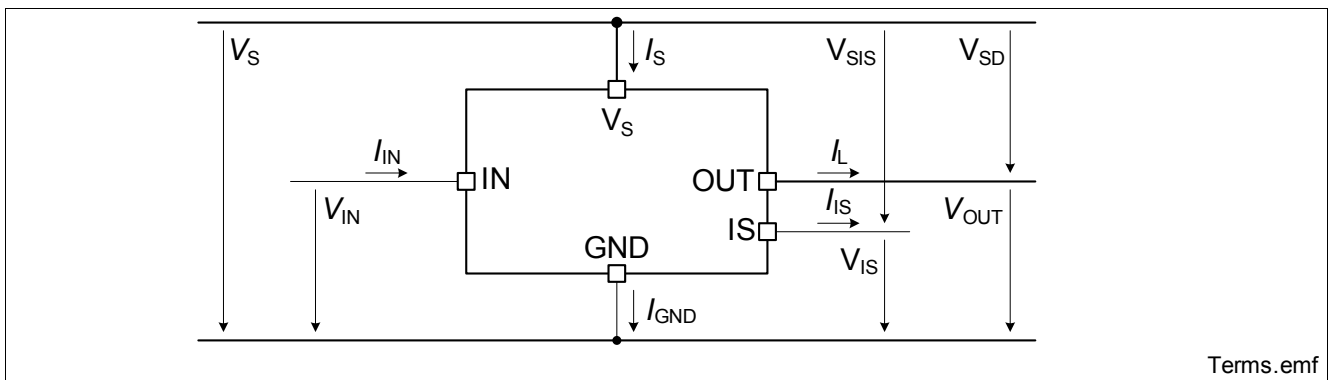

Figure 3 Definition of currents and voltages

4 General Product Characteristics

4.1 Absolute Maximum Ratings

Table 2 Absolute Maximum Ratings ¹⁾

$T_j = -40^\circ\text{C}$ to 150°C ; all voltages with respect to ground, positive current flowing into pin (unless otherwise specified)

Parameter	Symbol	Values		Unit	Note / Test Condition	Number
		Min.	Max.			
Supply voltages						
Supply Voltage	V_S	-0.3	28	V	–	P_4.1
Reverse Polarity Voltage on pin GND, IS	$ -V_{S(\text{REV})} $	0	16	V	^{2), 3)}	P_4.2
Supply voltage for short circuit protection	$V_{\text{BAT(SC)}}$	0	28	V	⁴⁾ $R_{\text{ECU}} = 20\text{m}\Omega$, $R_{\text{Cable}} = 6\text{m}\Omega/\text{m}$, $L_{\text{Cable}} = 1\mu\text{H}/\text{m}$, $l = 0$ or 5m , see Chapter 5.3.1	P_4.3
Supply voltage for load dump protection	$V_{S(\text{LD})}$	–	45	V	$R_1 = 2\Omega$ ⁵⁾ , $R_L = 1.0\Omega$, $t_d = 400\text{ms}$	P_4.4
Short Circuit Capability						
Short circuit cycle capability	n_{RSC1}	–	1 E6 (Grade A)	–	⁴⁾⁶⁾	P_4.21
IN + IS + GND pin						
Voltage at IN pin	V_{IN}	-0.3	6	V	–	P_4.5
Current through IN pin	I_{IN}	-2	2	mA	$t < 2\text{min}$	P_4.6
Voltage at IS pin	V_{IS}	-0.3	V_S	V	–	P_4.7
Current through IS pin	I_{IS}	-2	10	mA	–	P_4.8
Current through GND pin	I_{GND}	-2	10	mA	–	P_4.9
Power stage						
Load current	I_L	$-I_{L(\text{SC})}$	$I_{L(\text{SC})}$	A	–	P_4.10
Maximum energy dissipation for switching OFF an inductive load - single pulse	E_{AS}	–	280	mJ	$V_S = 13.5\text{V}$ $I_{L(0)} = 20\text{A}$ $T_{j(0)} = 150^\circ\text{C}$ See Figure 4 and Chapter 5.1.2	P_4.11
Maximum energy dissipation for switching OFF an inductive load - repetitive pulse	E_{AR}	–	84	mJ	$V_S = 13.5\text{V}$ $I_{L(0)} = 20\text{A}$ $T_{j(0)} = 105^\circ\text{C}$ See Figure 4 and Chapter 5.1.2	P_4.13
Temperatures						
Junction Temperature	T_j	-40	150	$^\circ\text{C}$	–	P_4.14

Table 2 Absolute Maximum Ratings (cont'd)¹⁾

$T_j = -40^{\circ}\text{C}$ to 150°C ; all voltages with respect to ground, positive current flowing into pin (unless otherwise specified)

Parameter	Symbol	Values		Unit	Note / Test Condition	Number
		Min.	Max.			
Dynamic temperature increase while switching	ΔT_j	–	60	K	–	P_4.15
Storage Temperature	T_{stg}	-55	150	$^{\circ}\text{C}$	–	P_4.16
ESD Susceptibility						
ESD Resistivity HBM all Pins to GND	V_{ESD1}	-2	2	kV	HBM ⁷⁾	P_4.17
ESD Resistivity HBM V_S vs. GND, V_S vs. OUT, OUT vs. GND	V_{ESD2}	-4	4	kV	HBM ⁷⁾	P_4.18
ESD Resistivity CDM all pins to GND	V_{ESD3}	-500	500	V	CDM ⁸⁾	P_4.19
ESD Resistivity CDM corner pins	V_{ESD4}	-750	750	V	CDM ⁸⁾	P_4.20

- 1) Not subject to production test, specified by design.
- 2) In case of reverse polarity voltage on pin IN, I_{IN} needs to be limited (see P_4.6) by external resistor R_{INPUT} , see [Figure 45](#).
- 3) In case of reverse polarity voltage, current through the OUT pin needs to be limited by external circuitry to prevent over heating (see P_4.14). Power dissipation during reverse polarity voltage can be calculated by [Equation \(3\)](#). Please note, build-in protection functions are not available during reverse polarity condition.
- 4) In accordance to AEC Q100-012 and AEC Q101-006.
- 5) $V_{\text{S(LD)}}$ is set up without the DUT connected to the generator per ISO 7637-1.
- 6) Test aborted after 1 E6 cycles.
- 7) ESD susceptibility, HBM according to ANSI/ESDA/JEDEC JS-001-2010
- 8) ESD susceptibility, Charged Device Model "CDM" EIA/JESD22-C101 or ESDA STM5.3.1

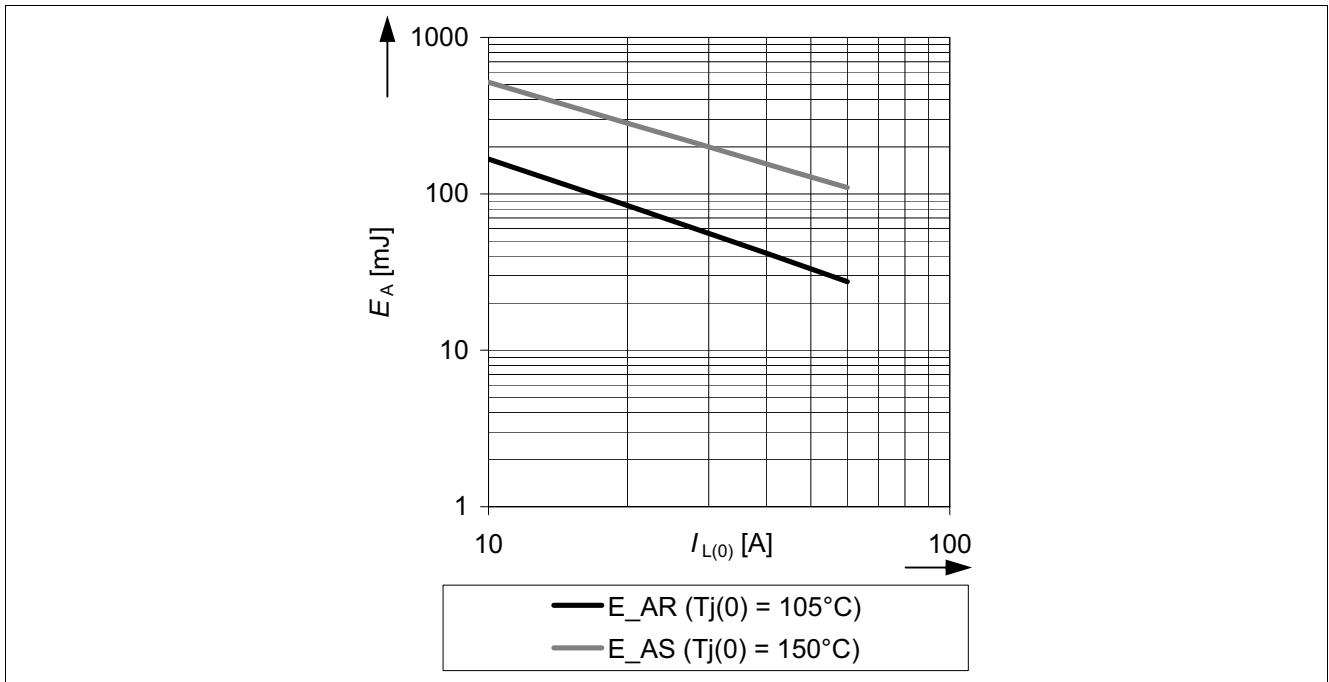

Figure 4 Maximum energy dissipation for switching OFF an inductive load E_A vs. load current

Notes

1. Stresses above the ones listed here may cause permanent damage to the device. Exposure to absolute maximum rating conditions for extended periods may affect device reliability.
2. Integrated protection functions are designed to prevent IC destruction under fault conditions described in the data sheet. Fault conditions are considered as “outside” normal operating range. Protection functions are not designed for continuous repetitive operation.

4.2 Functional Range

Table 3 Functional Range

Parameter	Symbol	Values		Unit	Note / Test Condition	Number
		Min.	Max.			
Nominal Supply Voltage Range for Operation	$V_{S(NOM)}$	6	19	V	–	P_4.23
Extended Supply Voltage Range for Operation	$V_{S(EXT)}$	$V_{S(UV)ON}$	28	V	¹⁾²⁾	P_4.24
Extended Supply Voltage Range for short dynamic undervoltage swings	$V_{S(DYN)}$	$V_{S(UV)OFF}$	$V_{S(UV)ON}$	V	¹⁾²⁾³⁾	P_4.25
Junction Temperature	T_j	-40	150	°C	–	P_4.26

- 1) see [Chapter 5.5, Undervoltage turn ON voltage](#) and [Undervoltage turn OFF voltage](#)
- 2) In extended supply voltage range, the device is functional but electrical parameters are not specified.
- 3) Operation only if supply voltage was in range of $V_{S(EXT)}$ before undervoltage swing. Otherwise, device will stay OFF.

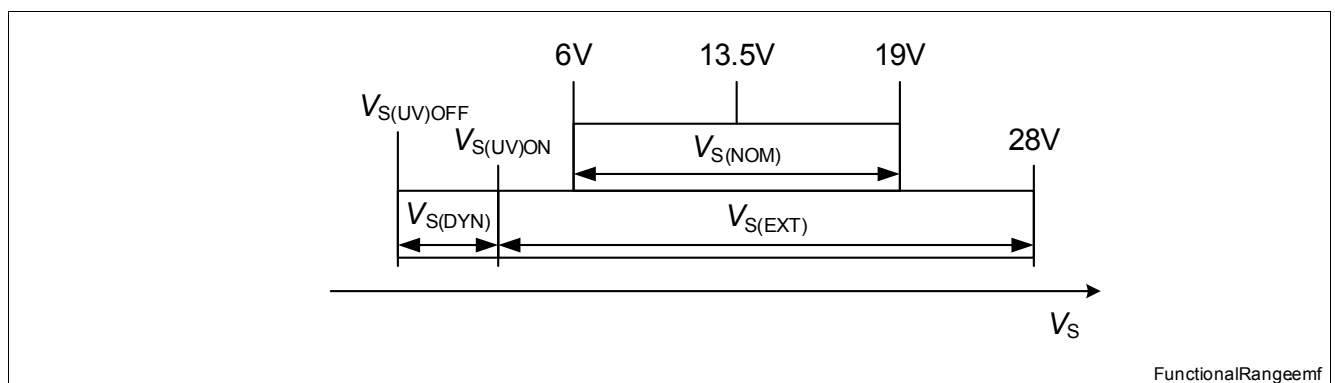

Figure 5 Overview of functional ranges

Note: Within the functional or operating range, the IC operates as described in the circuit description. The electrical characteristics are specified within the conditions given in the Electrical Characteristics table.

4.3 Thermal Resistance

Note: This thermal data was generated in accordance with JEDEC JESD51 standards. For more information, go to www.jedec.org.

Table 4 Thermal Resistance

Parameter	Symbol	Values			Unit	Note / Test Condition	Number
		Min.	Typ.	Max.			
Thermal Resistance - Junction to Case	$R_{thJC}^{1)}$	–	1	1.1	K/W	–	P_4.27
Thermal Resistance - Junction to Ambient - 2s2p	$R_{thJA_2s2p}^{1)}$	–	22	–	K/W	²⁾	P_4.29

- 1) Not subject to production test, specified by design.
- 2) Specified RthJA value is according to Jedec JESD51-2,-5,-7 at natural convection on FR4 2s2p board; The Product (Chip+Package) was simulated on a 76.2 × 114.3 × 1.5 mm board with 2 inner copper layers (2 × 70 mm Cu, 2 × 35 mm Cu). Where applicable a thermal via array under the exposed pad contacted the first inner copper layer.

Figure 6 and Figure 7 are showing the typical thermal impedance of BTF50060-1TEA mounted according to Jedec JESD51-2,-5,-7 at natural convection on FR4 1s and 2s2p board. The product (chip + package) was simulated on a 76.4 × 114.3 × 1.5 mm board with 2 inner copper layers (2× 70µm Cu, 2× 35µm Cu). Where applicable, a thermal via array under the exposed pad contacted the first inner copper layer. The PCB layer structure is shown in Figure 8. The PCB layout is shown in Figure 9.

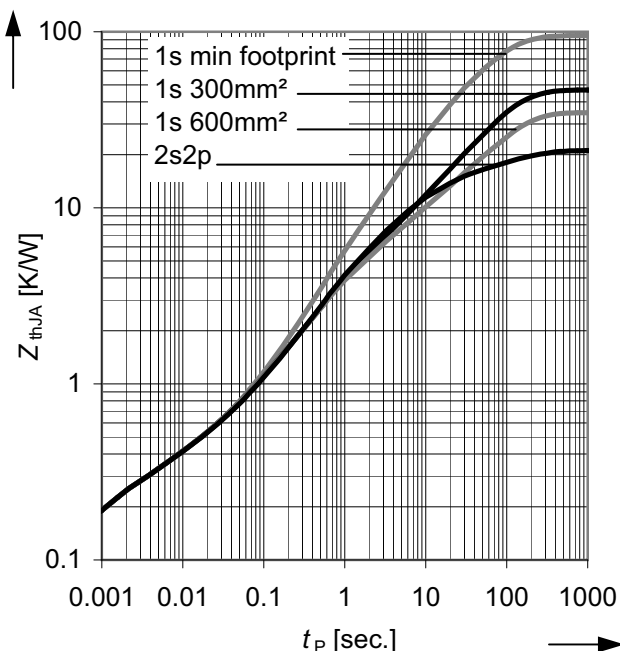

Figure 6 Typical Transient Thermal Impedance $Z_{th(JA)} = f(t_p)$ for different cooling areas

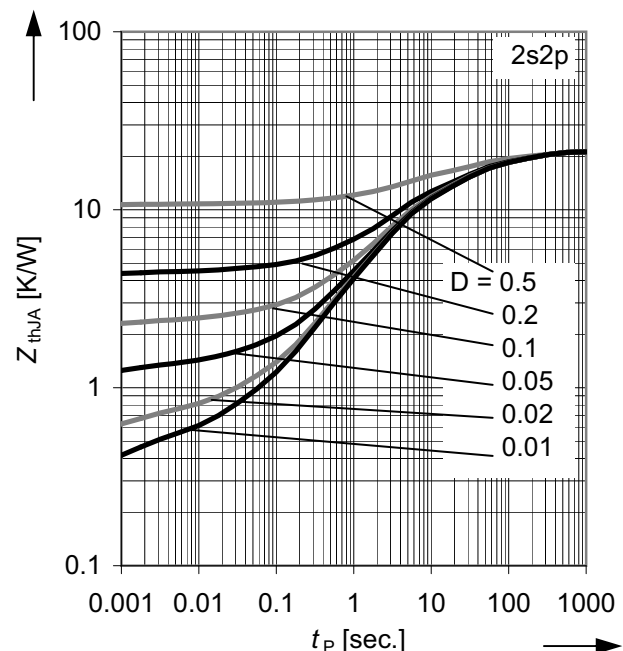

Figure 7 Typical Transient Thermal Impedance $Z_{th(JA)} = f(t_p)$ for PWM operation with duty cycles $D = t / t_{period}$ on a 2s2p PCB

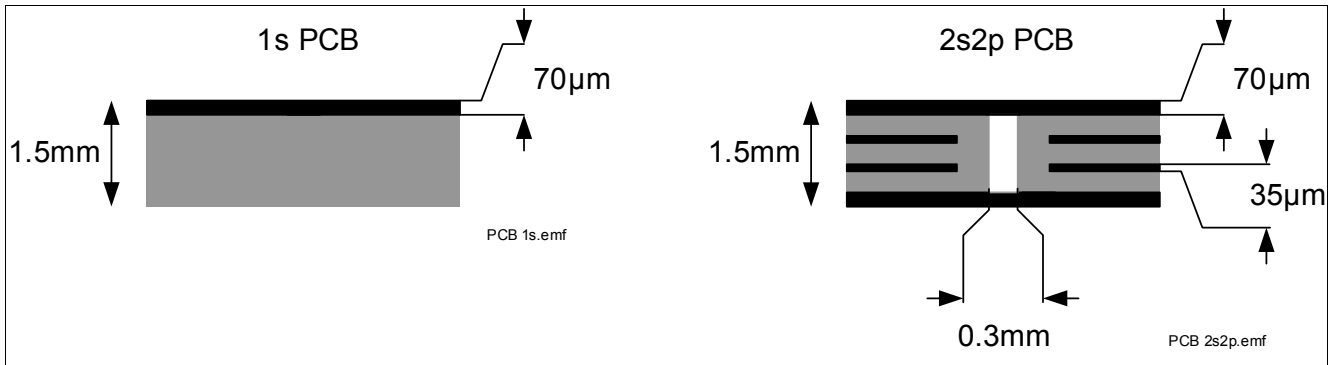

Figure 8 Cross section of 1s and 2s2p PCB used for Z_{thJA} simulation

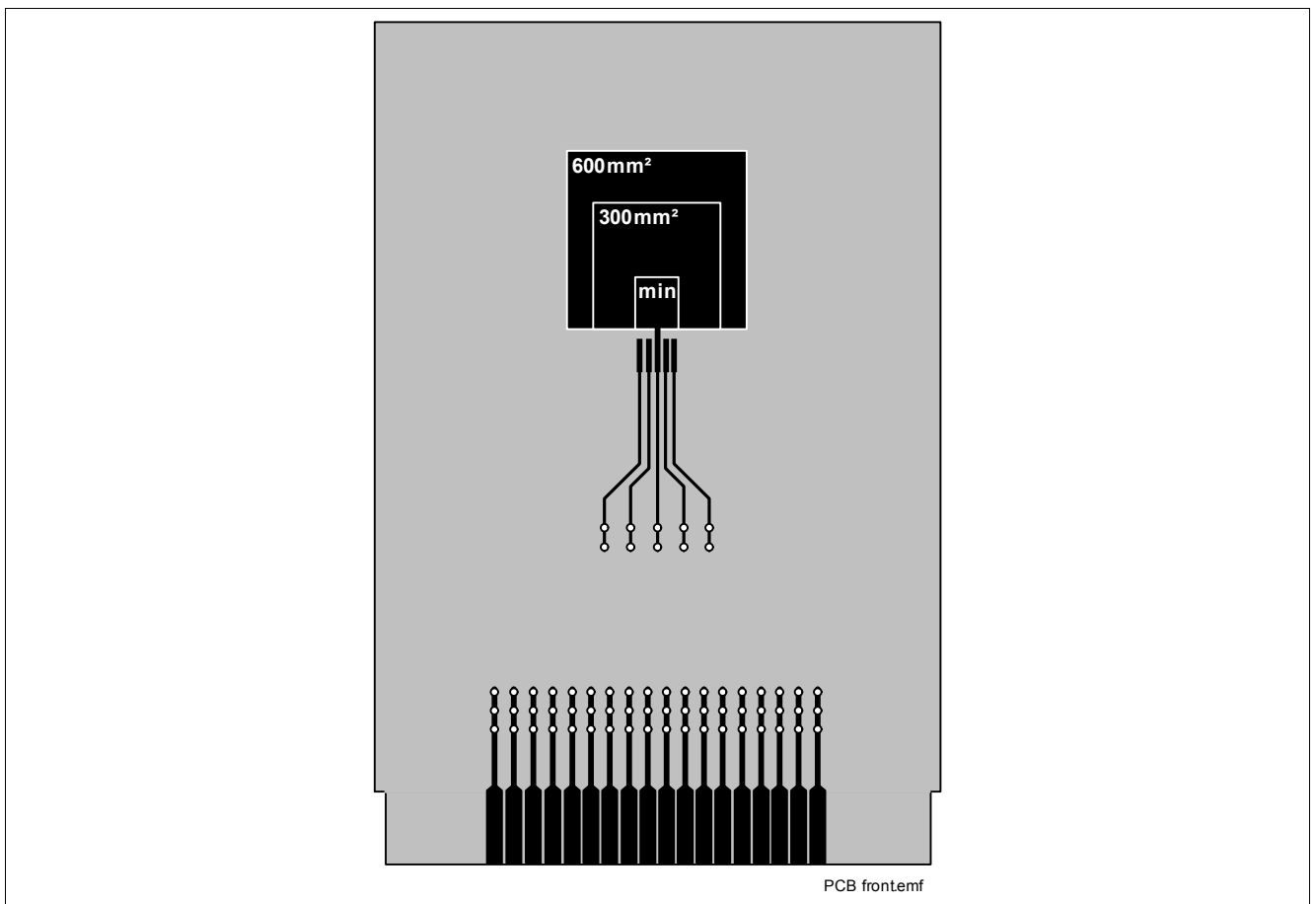

Figure 9 Front view of PCB layout used for Z_{thJA} simulation

5 Functional Description

5.1 Power Stage

The power stage is built by a P-channel vertical power MOSFET (DMOS). The ON-state resistance $R_{DS(ON)}$ depends on the supply voltage V_S as well as the junction temperature T_j . **Figure 26** shows the dependencies for the typical ON-state resistance. The behavior in reverse polarity is described in **Chapter 5.3.4**. A HIGH signal at the input pin (see **Chapter 5.2**) causes the power DMOS to switch ON. A LOW signal at the input pin causes the power DMOS to switch OFF.

5.1.1 Switching a Resistive Load

Defined slew rates for turn ON and OFF as well as edge shaping support PWM'ing of the load while achieving lowest EMC emission at minimum switching losses. **Figure 10** shows the typical timing when switching a resistive load. Please note: if the devices logic is inactive, e.g. because the IN signal was LOW for $t > t_{RESET}$, the logic of the device needs a wake-up time of t_{wake} for turning the output ON in addition to the turn ON time t_{ON} . See also **Figure 11**.

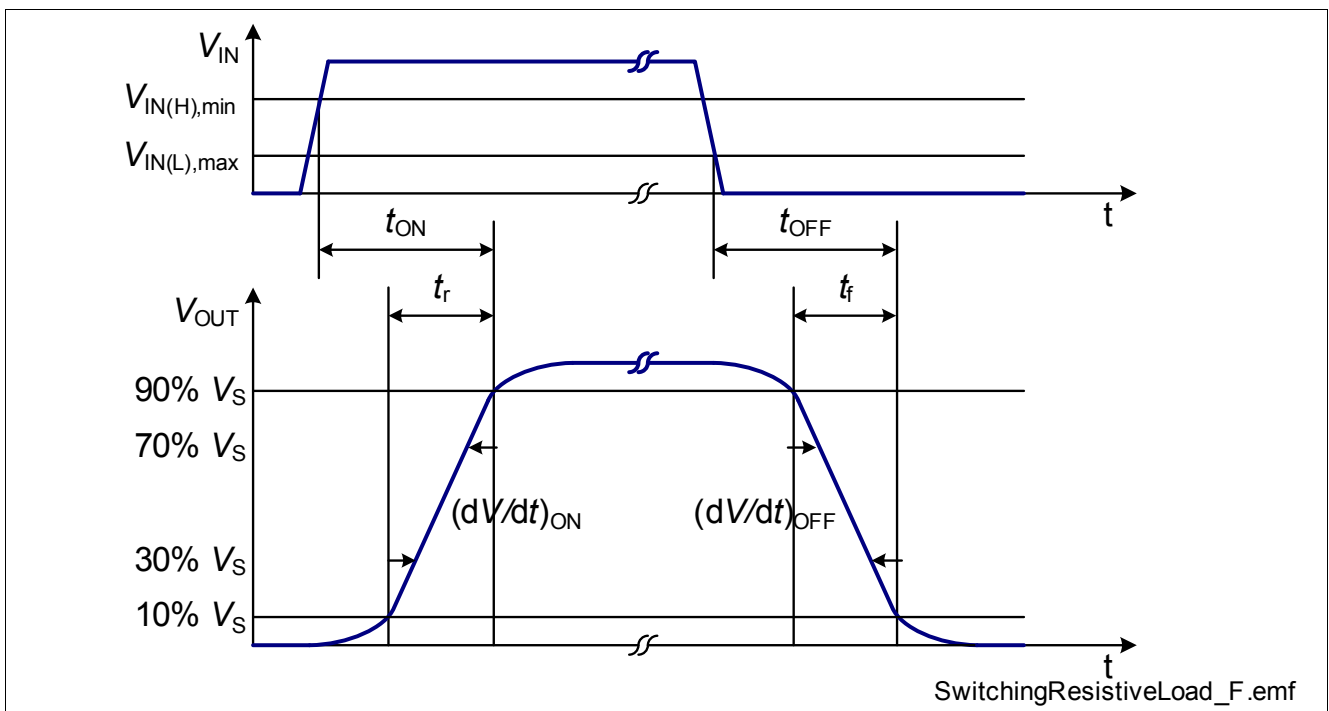

Figure 10 Switching a resistive load

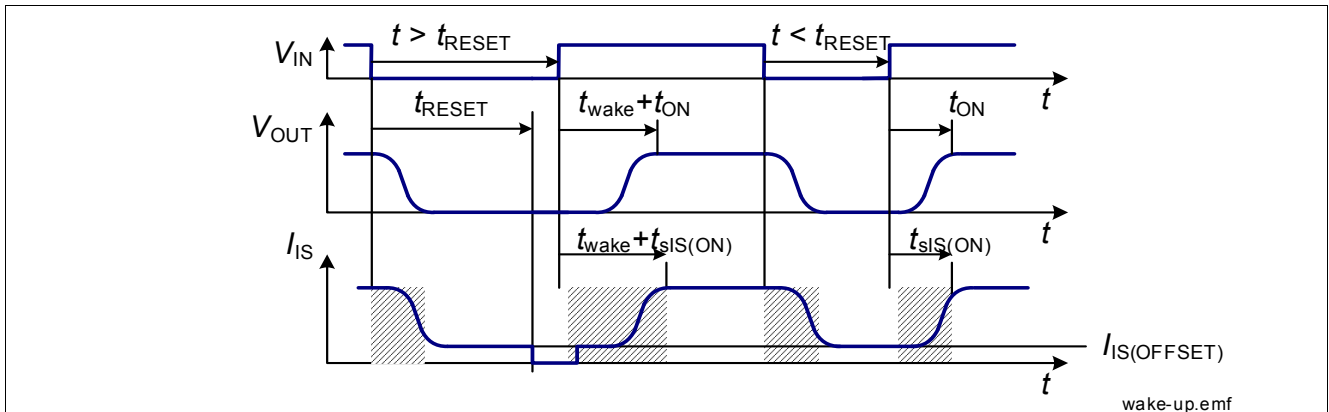

Figure 11 Wake up timing

5.1.2 Switching an Inductive Load - Infineon® SMART CLAMPING

When switching OFF inductive loads with no path for load current freewheeling available, the output voltage V_{OUT} drops below ground potential due to the involved inductance ($-di_L/dt = -v_L/L$; $-V_{OUT} \cong -V_L$). To prevent the destruction of the device due to high voltages, there is a voltage clamp mechanism implemented that keeps the negative output voltage at a certain level ($-V_{OUT} = V_S - V_{SD(CL)}$). Please refer to [Figure 1](#) and [Figure 12](#) for details.

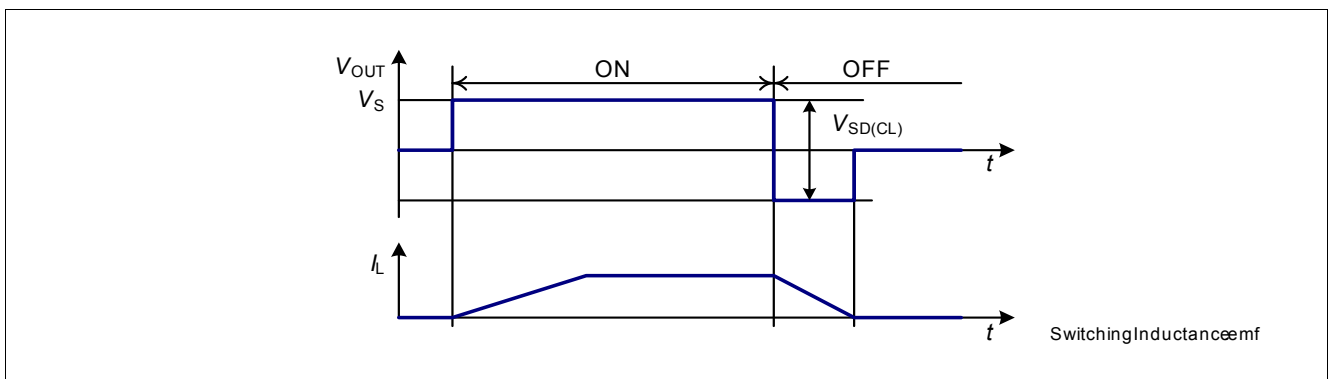

Figure 12 Switching an inductance

Nevertheless, the energy capability of the device is limited because the energy is converted into heat. That's why the maximum allowed load inductance is limited as well. Please see [Figure 4](#) for limitations of energy and load inductance.

For calculating the demagnetization energy, [Equation \(1\)](#) may be used:

$$E_A = V_{SD(CL)} \times \frac{L}{R_L} \times \left[\frac{V_S - V_{SD(CL)}}{R_L} \times \ln \left(1 + \frac{R_L \times I_L}{V_{SD(CL)} - V_S} \right) + I_L \right] \quad (1)$$

The equation can be simplified under the assumption of $R_L = 0 \Omega$ to:

$$E_A = \frac{1}{2} \times L \times I_L^2 \times \frac{V_{SD(CL)}}{V_{SD(CL)} - V_S} \quad (2)$$

The BTF50060-1TEA provides Infineon® SMART CLAMPING functionality. To optimize the energy capability for single and parallel operation, the clamp voltage $V_{SD(CL)}$ increases over the junction temperature T_j and load current I_L . [Figure 33](#) shows the dependency from T_j for the typical $V_{SD(CL)}$. Please refer also to [Figure 15](#).

5.1.3 Switching a Capacitive Load

A capacitive load's dominant characteristic is its inrush current. The BTF50060-1TEA can support inrush currents up to $I_{L(SC)}$. If the inrush current reaches $I_{L(SC)}$, the device may detect a short circuit condition and switches OFF. For a description of the short circuit protection mechanism, please refer to [Chapter 5.3.1](#).

5.1.4 Inverse Load Current Operation

In case of a negative load current, e.g. caused by load operating as a generator, the device can not block a current flowing through the intrinsic body diode. See [Figure 13](#). The power stage of the device can be switched ON or stays ON as long as $V_{IN} = \text{HIGH}$, reaching the same $R_{DS(ON)}$ as for positive load currents, if no fault condition is detected. In case of fault condition, the logic of the device will switch OFF the power stage and supply a fault signal $I_{IS(fault)}$. Since the device can not block a negative load current (even under fault conditions), it can not protect itself from overload condition. In the application, overload conditions, e.g. over temperature, must not occur during inverse load current operation.

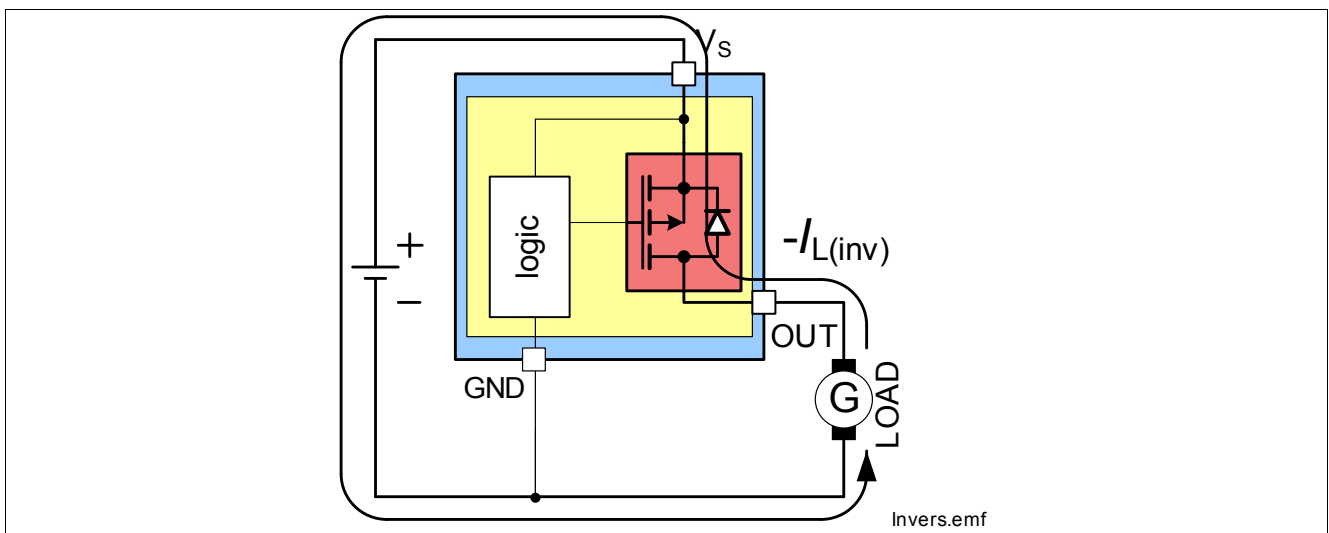

Figure 13 Inverse load current operation

5.2 Input Circuit

The input circuitry is compatible with 3.3 and 5V micro controllers. If V_{IN} is set to $V_{IN} = V_{IN(H)}$ ($V_{IN} = \text{HIGH}$), the device will turn ON. See [Figure 10](#) for the timings. If V_{IN} is set to $V_{IN} = V_{IN(L)}$ ($V_{IN} = \text{LOW}$), the power stage of the device will be turned OFF. The input circuitry has a hysteresis ΔV_{IN} . The input circuitry is compatible with PWM applications. [Figure 14](#) shows the electrical equivalent input circuitry. The logic of the BTF50060-1TEA stays active for a delay time t_{RESET} after the switch OFF signal.

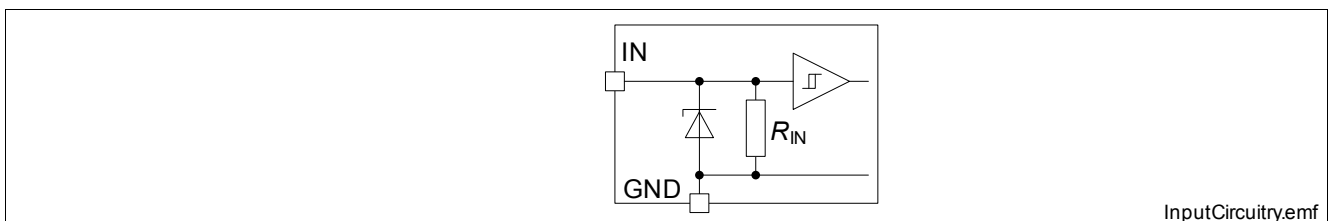

Figure 14 Input pin circuitry

Applying an input voltage of $V_{IN} > 20V$ (absolute maximum ratings exceeded!) may force the BTF50060-1TEA to deactivate parts of the logic circuitry. This includes the undervoltage shutdown, the undervoltage restart delay, and the analog sense function. In this case, also the short circuit shutdown threshold $I_{L(SC)}$ is set to typically 50A, and

Functional Description

the latch reset time t_{RESET} is reduced to typically 200 μs . To reset this behavior, set input voltage to $V_{\text{IN}} = \text{LOW}$ for $t > 300\mu\text{s}$.

5.3 Protection Functions

The BTF50060-1TEA provides embedded protective functions. Integrated protection functions are designed to prevent the destruction of the IC from fault conditions described in the data sheet. Fault conditions are considered as “outside” normal operating range. Protection functions are designed for neither continuous nor repetitive operation.

In case of overload, high inrush currents, or short circuit to ground, the BTF50060-1TEA offers several protection mechanisms. **Figure 15** describes the functionality of the diagnosis and protection block.

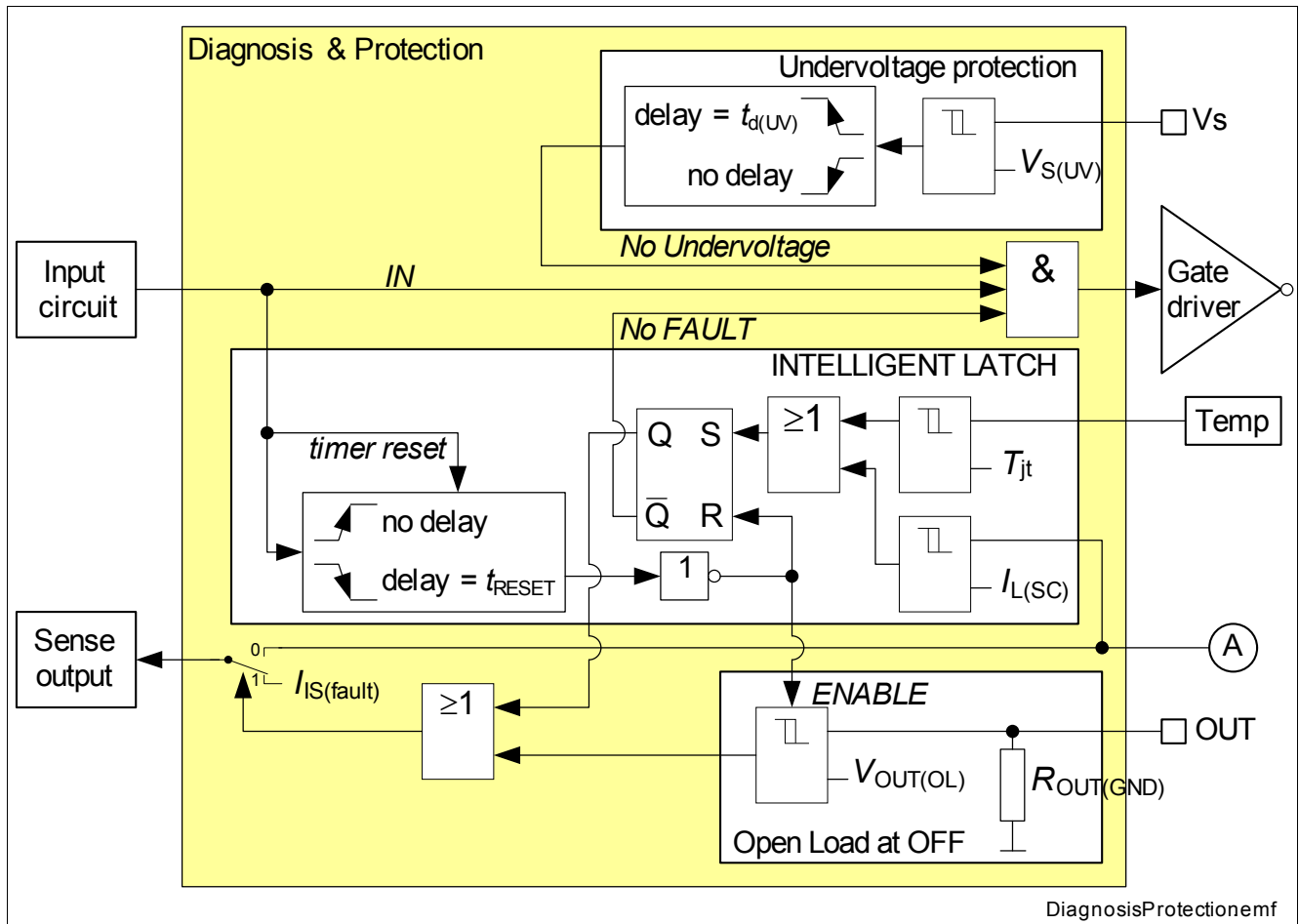

Figure 15 Diagram of Diagnosis & Protection block

5.3.1 Protection by Over Current Shutdown

The internal logic permanently monitors the load current I_L . In the event of a load current exceeding the short circuit shutdown threshold ($I_L > I_{L(SC)}$), the output will switch OFF with a latching behavior. During an over current shutdown, an overshooting $I_{L(SC)peak}$ may occur, depending on the short circuit impedances. For the case the device is in ON state while short circuit appears, the typical overshooting $I_{L(SC)peak}$ as a function of the steepness of the short circuit current dI_{SC}/dt , see **Chapter 6.2.3**.

For a detailed description of the latching behavior, please see **Chapter 5.3.3**.

At lower supply voltages the current tripping level $I_{L(SC)}$ will decrease depending on the supply voltage. At $V_S = 4.7V$, the current tripping level will be reduced to $I_{L(SC)LV}$. Please refer to **Figure 35** for typical current tripping level $I_{L(SC)}$ as a function of the supply voltage V_S .

5.3.2 Protection by Over Temperature Shutdown

The internal logic permanently monitors the junction temperature of the output stage. In the event of an over temperature ($T_j > T_{jt}$) the output will immediately switch OFF with a latching behavior, see [Chapter 5.3.3](#) for details.

5.3.3 Infineon® INTELLIGENT LATCH

The BTF50060-1TEA provides Infineon® INTELLIGENT LATCH to avoid permanent resetting of a protective, latched switch OFF caused by over current shutdown or over temperature shutdown) in PWM applications. To reset a latched protective switch OFF the fault has to be acknowledged by commanding the input LOW for a minimum duration of t_{reset} . See [Figure 16](#) for details.

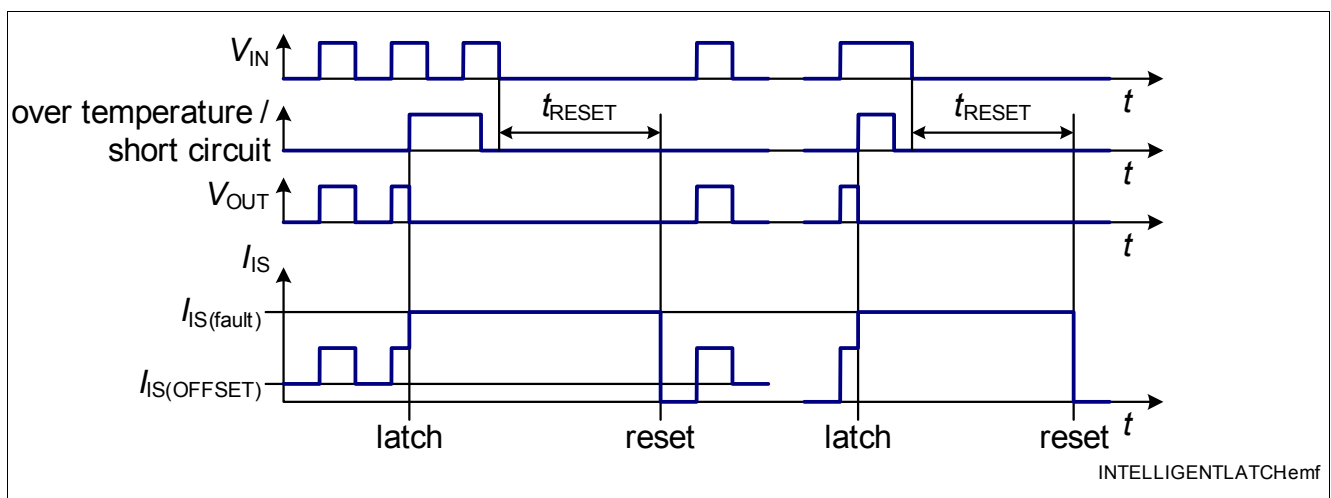

Figure 16 Infineon® INTELLIGENT LATCH - fault acknowledge and latch reset

5.3.4 Reverse Polarity Protection

Reverse polarity condition is the mix-up of the power supply connections of the entire application. This means, application GND connector is connected to positive supply voltage, while V_S pin is connected to negative supply voltage or ground potential. See [Figure 17](#) and [Figure 45](#).

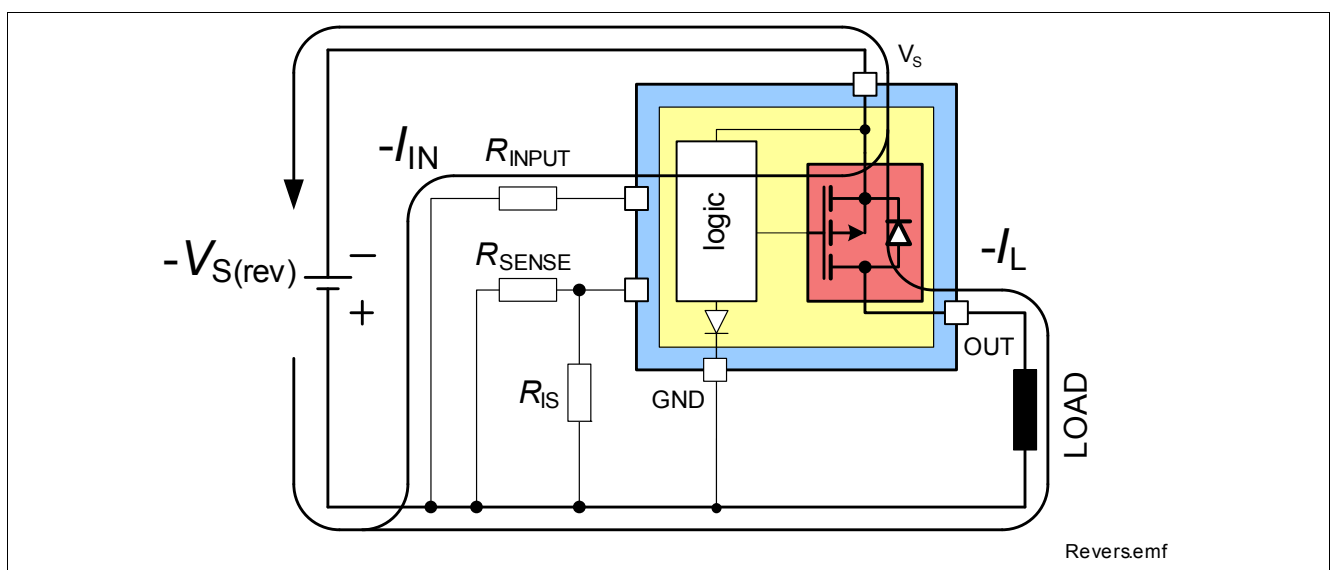

Figure 17 Reverse polarity condition

Under reverse polarity condition, the output stage can not block a current flow. It will conduct a load current via the intrinsic body diode. The current through the output stage has to be limited either by the load itself or by external circuitry, to avoid over heating of the power stage. Power losses in the power stage during reverse polarity condition can be calculated by [Equation \(3\)](#):

$$P_{rev} = (-I_{L(rev)}) \times (-V_{SD(rev)}) \tag{3}$$

Additionally, the current into the logic pins has to be limited to the maximum current described in [Chapter 4.1](#) with an external resistors. [Figure 46](#) shows a typical application. Resistors R_{INPUT} and R_{SENSE} are used to limit the current in the logic of the device and in the ESD protection stage. The recommended value for $R_{INPUT} = R_{SENSE} = 10k\Omega$. As long as $|-V_{S(rev)}| < 16V$, the current through the GND pin of the device is blocked by an internal diode.

5.3.5 Protection during Loss of Ground

In case of loss of the module ground or device ground connection (GND pin) the device protects itself by automatically turning OFF (when it was previously ON) or remains OFF (even if the load remains connected to ground), regardless if the input is driven HIGH or LOW. In case GND recovers the device may need a reset via the IN pin to return to normal operation.

5.3.6 Protection during Loss of Load or Loss of V_S Condition

In case of loss of load with charged primary inductances the maximum supply voltage has to be limited. It is recommended to use a Z-diode, a varistor ($V_{Za} < 40V$) or V_S clamping power switches with connected loads in parallel.

In case of loss of a charged inductive load, disturbances on pin OUT may require a reset on IN pin for the device to regain normal operation.

In case of loss of V_S connection with charged inductive loads, a current path with load current capability has to be provided, to demagnetize the charged inductances. It is recommended to use a diode, a Z-diode or a varistor ($V_{Zb} < 16V$, $V_{ZL} + V_D < 16V$).

For higher clamp voltages currents through all pins have to be limited according to the maximum ratings. Please see [Figure 18](#) and [Figure 19](#) for details.

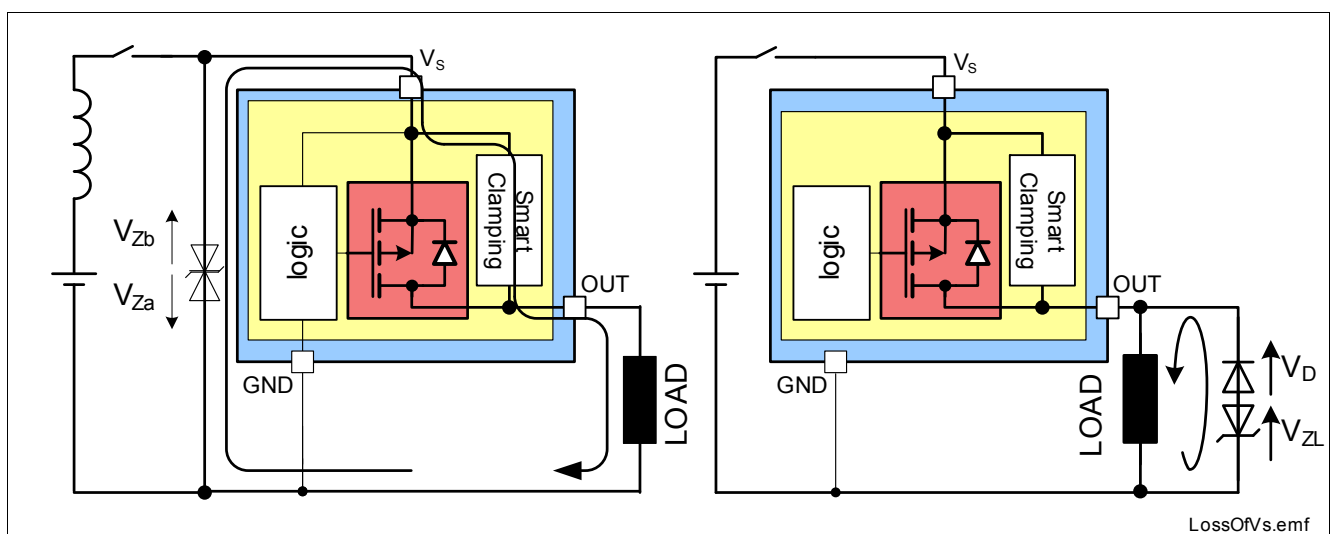

Figure 18 Loss of V_S

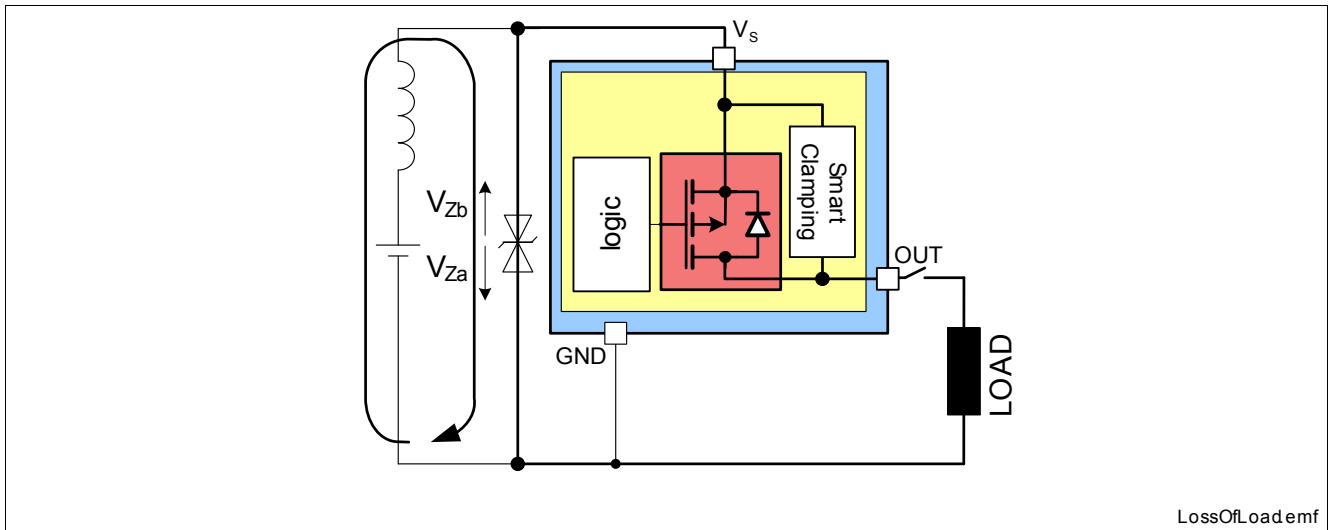

Figure 19 Loss of load

5.3.7 Protection during ESD or Over Voltage Condition

All logic pins have ESD protection. A dedicated clamp mechanism protects the logic IC against transient over voltages. See [Figure 20](#) for details.

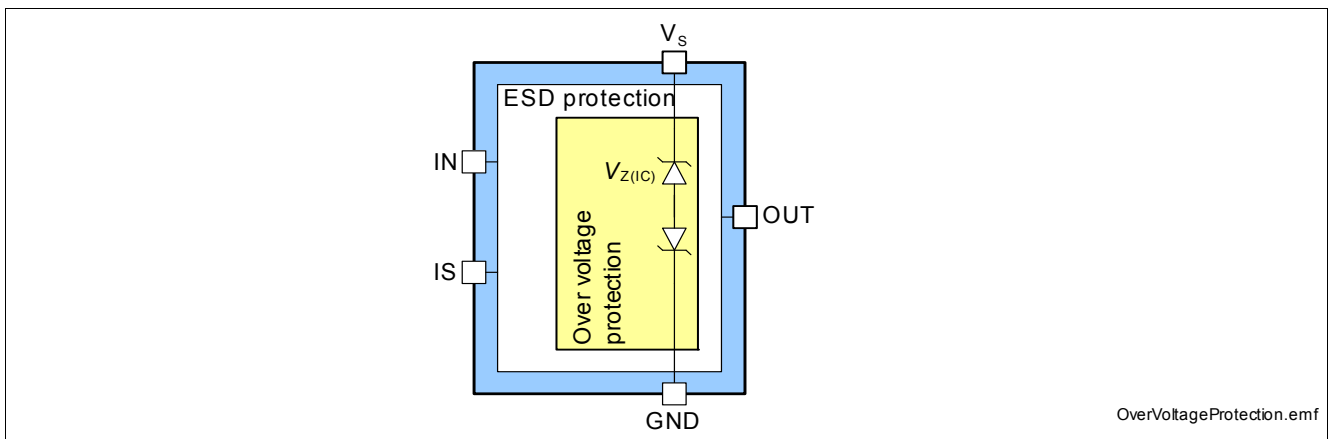

Figure 20 Over voltage protection

In the case ($V_s > \max V_{S(SC)}$) & ($V_s < V_{SD(CL)}$), the output transistor is still operational and follows the input. Parameters are no longer warranted and lifetime is reduced compared to normal mode. This specially impacts the short circuit robustness, as well as the maximum energy E_{AS} the device can handle.

The BTF50060-1TEA provides Infineon® SMART CLAMPING functionality, which suppresses non nominal over voltages by actively clamping the over voltage across the power stage and the load. This is achieved by controlling the clamp voltage $V_{SD(CL)}$ depending on the junction temperature T_j and the load current I_L . See [Figure 15](#) for details. Please refer also to [Chapter 5.1.2](#).

5.4 Diagnosis Functions

For diagnosis purpose, the BTF50060-1TEA provides an enhanced analog sense signal at the pin IS. For an overview of the diagnosis functions, you may have a look at **Figure 15 “Diagram of Diagnosis & Protection block”**.

5.4.1 Sense Output

The current sense output is a current source driving a signal I_{IS} proportional to the load current (see **Equation (5)**) as long as no “hard” failure mode occurs (short circuit to GND / over temperature) and $V_{SIS} = V_S - V_{IS} > 3V$. It is activated and deactivated by the input signal. Usually, in the application a pull-down resistor R_{IS} is connected between the current sense pin IS and GND pin. A typical value is $R_{IS} = 1.0\text{ k}\Omega$. **Figure 46** shows a simplified application setup.

Table 5 is giving a quick reference for the logic / analog state of the IS pin during device operation.

In case a short circuit or an over temperature condition is detected, the sense output is supplying a fault signal $I_{IS(\text{fault})}$. The fault signal is reset by an input signal being LOW for $t > t_{\text{RESET}}$. As long as an open load, short-to- V_S or inverse operation is detected while the device is in OFF state, the sense output also supplies the fault signal $I_{IS(\text{fault})}$. The timings and logic of the IS pin are described in **Figure 21**. During output turning ON or OFF, the sense signal is invalid. Please note: if the devices logic is inactive, e.g. because the IN signal was LOW for $t > t_{\text{RESET}}$, the logic of the device needs a wake-up time of t_{wake} for activating the sense output in addition to the current sense settling time for turn ON $t_{\text{SIS(ON)}}$. See also **Figure 11**.

Table 5 Truth Table for Sense Signal

Operation mode	Input level	Output level	Sense output
Normal operation	HIGH ¹⁾	$V_{\text{OUT}} = V_S - R_{\text{DS(ON)}} * I_L$	$I_{\text{IS}} = (I_L / k_{\text{IS}}) + I_{\text{IS(OFFSET)}}$
	LOW ²⁾ for $t < t_{\text{RESET}}$	$V_{\text{OUT}} \sim \text{GND}$	$I_{\text{IS}} = I_{\text{IS(OFFSET)}}$
	LOW for $t > t_{\text{RESET}}$	$(V_{\text{OUT}} < V_{\text{OUT(OLL)}})$	$Z^3) (I_{\text{IS}} = I_{\text{IS(LL)}})$
Inverse operation	HIGH	$V_{\text{OUT}} > V_S$	$I_{\text{IS}} \leq I_{\text{IS(OFFSET)}}$
	LOW for $t < t_{\text{RESET}}$		$I_{\text{IS}} = I_{\text{IS(OFFSET)}}$
	LOW for $t > t_{\text{RESET}}$		$I_{\text{IS}} = I_{\text{IS(FAULT)}}$
After short circuit to GND or over temperature detection	HIGH or LOW for $t < t_{\text{RESET}}$	$V_{\text{OUT}} \sim \text{GND}$	$I_{\text{IS}} = I_{\text{IS(FAULT)}}$
	LOW for $t > t_{\text{RESET}}$		$Z (I_{\text{IS}} = I_{\text{IS(LL)}})$
Short circuit to V_S	HIGH	$V_{\text{OUT}} = V_S$	$I_{\text{IS}} \leq I_{\text{IS(OFFSET)}}$
	LOW for $t < t_{\text{RESET}}$		$I_{\text{IS}} = I_{\text{IS(OFFSET)}}$
	LOW for $t > t_{\text{RESET}}$		$I_{\text{IS}} = I_{\text{IS(FAULT)}}$
Open load	HIGH	$V_{\text{OUT}} = V_S$	$I_{\text{IS}} \leq I_{\text{IS(OFFSET)}}$
	LOW for $t < t_{\text{RESET}}$	$V_{\text{OUT}} > V_{\text{OUT(OLH)}}^4)$	$I_{\text{IS}} = I_{\text{IS(OFFSET)}}$
	LOW for $t > t_{\text{RESET}}$		$I_{\text{IS}} = I_{\text{IS(FAULT)}}$

1) HIGH: $V_{\text{IN}} = V_{\text{IN(H)}}$

2) LOW: $V_{\text{IN}} = V_{\text{IN(L)}}$

3) Z: High impedance

4) Can be achieved e.g. with external pull up resistor R_{OL} , see **Figure 46**.

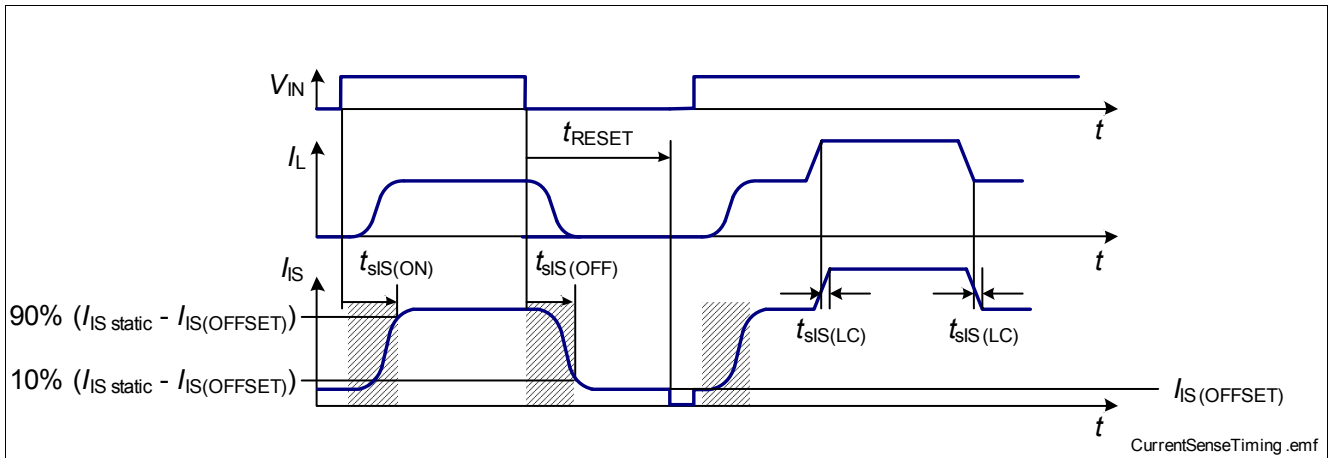

Figure 21 Sense output timing

Figure 22 shows the current sense as a function of the load current in the power DMOS. The curves represent the minimum and maximum values for the sense current, as well as the ideal sense current, assuming an ideal k_{IS} factor value as well as an ideal $I_{IS(OFFSET)}$.

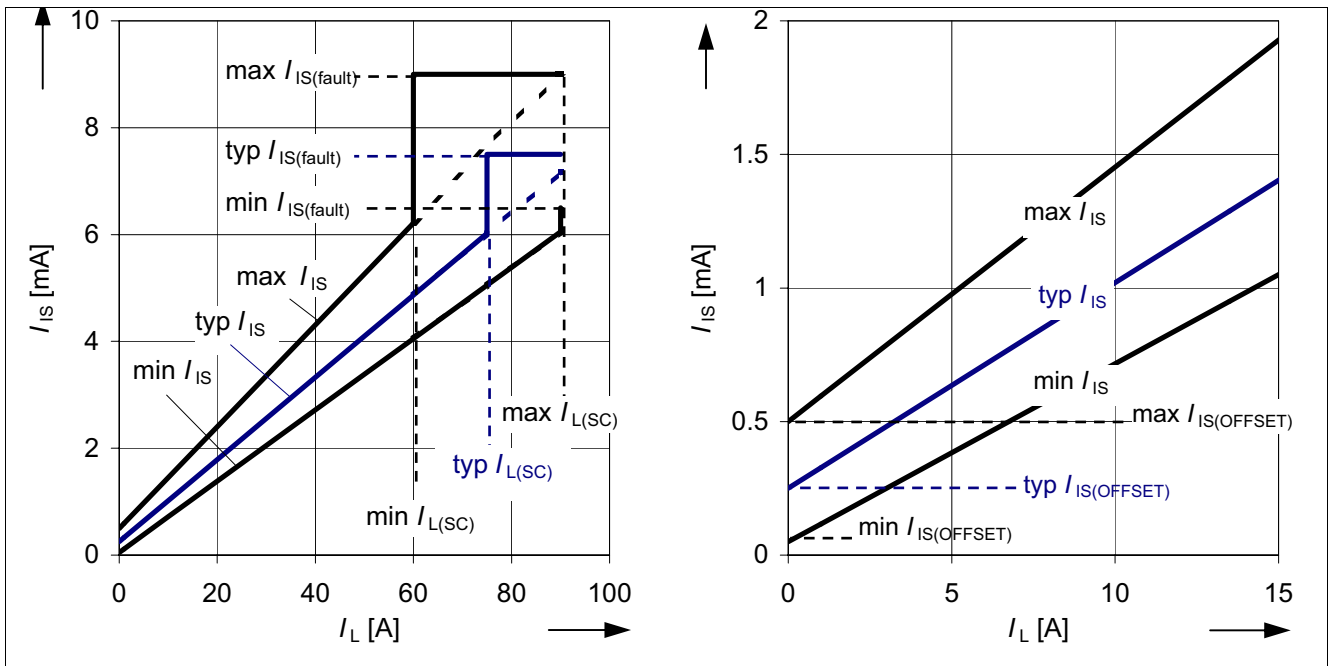

Figure 22 Sense current as a function of the load current ($V_{SIS} > 3V$)

The sense current can be calculated out of the load current by the following **Equation (4)**:

$$I_{IS} = \frac{1}{k_{IS}} \times I_L + I_{IS(OFFSET)} \tag{4}$$

Or, vice versa, the load current can be calculated out of the sense current by following **Equation (5)**:

$$I_L = k_{IS} \times (I_{IS} - I_{IS(OFFSET)}) \tag{5}$$

For definition of k_{IS} , the following [Equation \(6\)](#) is used:

$$k_{IS} = \frac{I_{L1} - I_{L2}}{I_{IS}(I_{L1}) - I_{IS}(I_{L2})} \quad (6)$$

I_{L1} and I_{L2} are two different load currents, $I_{IS(IL1)}$ and $I_{IS(IL2)}$ are the corresponding sense currents.

5.4.2 Enhancing Accuracy of the Sense Output by End of Line Calibration

For some applications it may be necessary to measure the load current with very high accuracy. To increase the device accuracy, different methods can be used, e.g. single point calibration or dual point calibration.

The variance of the sense current at a certain load current depends on the variance of the factor k_{IS} as well as on the variance of the offset current $I_{IS(OFFSET)}$. The temperature variance of the factor k_{IS} over the temperature range is described with the parameter $\Delta k_{IS,Temp}$.

$$\Delta k_{IS(Temp)} = \max[|k_{IS}(-40^{\circ}C) - k_{IS}(25^{\circ}C)|; |k_{IS}(150^{\circ}C) - k_{IS}(25^{\circ}C)|] \quad (7)$$

The variance of the sense current offset over the temperature range is defined as shown in [Equation \(8\)](#):

$$\Delta I_{IS(OFFSET)} = \max[|I_{IS(OFFSET)}(-40^{\circ}C) - I_{IS(OFFSET)}(25^{\circ}C)|; |I_{IS(OFFSET)}(150^{\circ}C) - I_{IS(OFFSET)}(25^{\circ}C)|] \quad (8)$$

5.4.3 Short-to-Battery detection / Open Load Detection in OFF state

The BTF50060-1TEA provides open load diagnosis in OFF state. This is achieved by monitoring the OUT voltage. The open load at OFF diagnosis is activated if $V_{IN} = \text{LOW}$ for $t > t_{RESET}$. An open load or short-to-battery is detected if $V_{OUT} > V_{OUT(OLH)}$. To provoke this condition during Open Load, it may be necessary to use an external pull up resistor R_{OL} (see [Figure 46](#)). In case of detecting a shorted load to battery, open load, or inverse operation in OFF state, the pin IS provides a defined fault current $I_{IS(fault)}$. If V_{OUT} drops below $V_{OUT(OLL)}$, or V_{IN} is set to HIGH, the fault signal is removed. [Figure 23](#) shows the behavior of the open load at OFF diagnosis. [Figure 43](#) and [Figure 44](#) provide the typical behavior of $V_{OUT(OLH)}$ and $V_{OUT(OLL)}$ as a function of the supply voltage and junction temperature. The device internally connects OUT with GND pin with an effective resistor $R_{OUT(GND)}$. In case the application provides high leakage current outside of the BTF50060-1TEA between V_S and OUT, it may be necessary to use an external resistor R_{L_OL} to disable open load detection. [Figure 46](#) gives an example of external circuitry for enabling / disabling open load detection in OFF state.

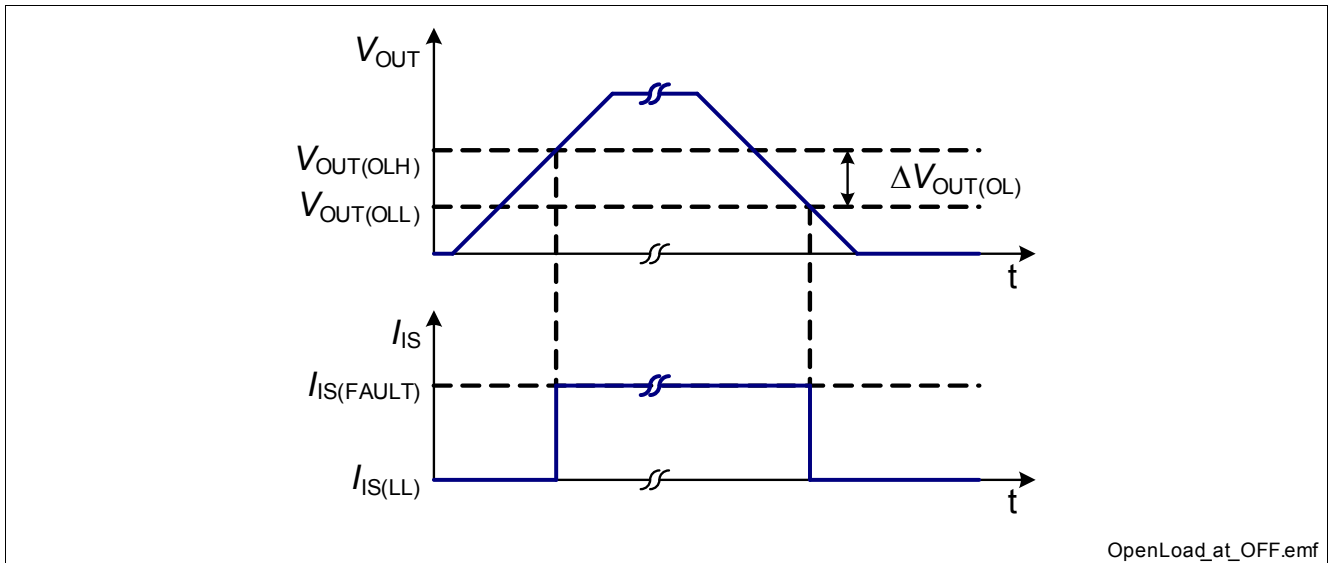

Figure 23 Open load detection in OFF state

5.5 Undervoltage Shutdown & Restart

The BTF50060-1TEA switches OFF whenever V_S drops below $V_{S(UV)OFF}$. The device restarts automatically after the supply voltage increases to a sufficient level ($V_S > V_{S(UV)ON}$) and a delay time of $t_{delay(UV)}$, if the input pin IN is HIGH. Please see [Figure 24](#) for details. The fault signal is reset if V_S is below $V_{S(UV)}$ for more than typ. 70µs.

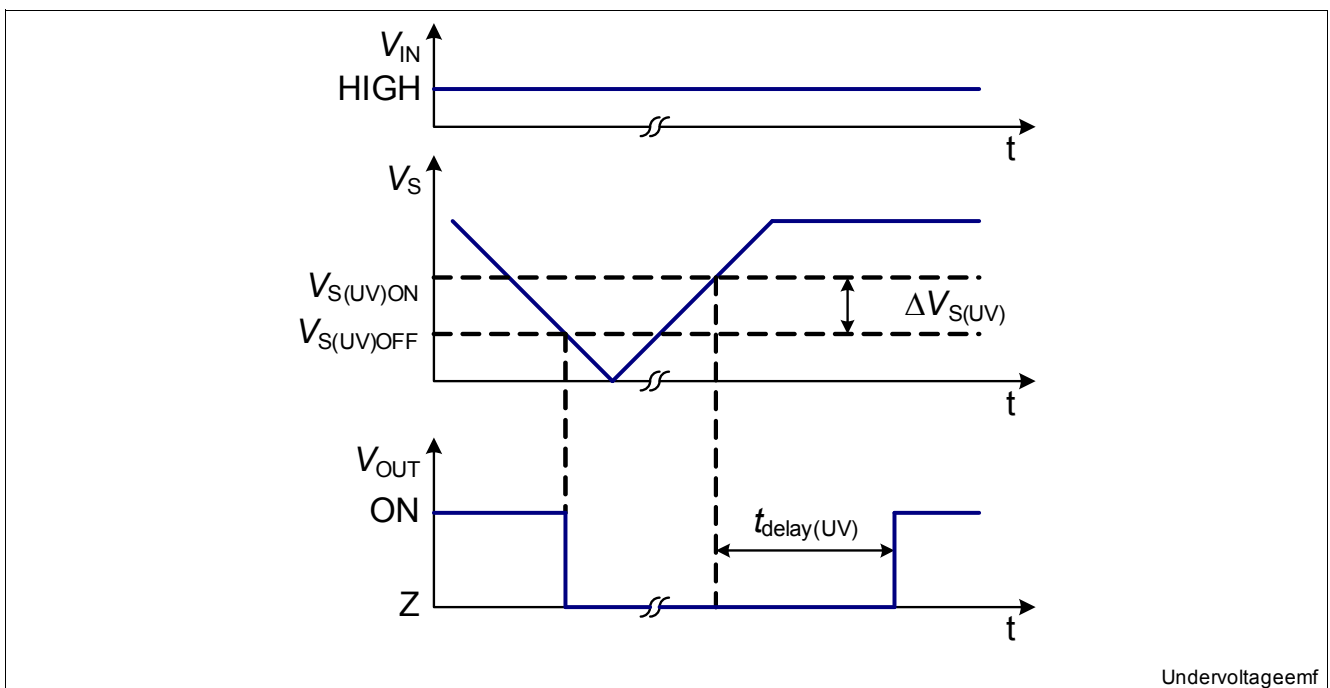

Figure 24 Undervoltage shutdown and restart

6 Electrical Characteristics BTF50060-1TEA

6.1 Electrical Characteristics Table

Table 6 Electrical Characteristics: BTF50060-1TEA

$V_S = 6V$ to $19V$, $T_j = -40^\circ C$ to $150^\circ C$, all voltages with respect to ground, positive current flowing into pin (unless otherwise specified)

Parameter	Symbol	Values			Unit	Note / Test Condition	Number
		Min.	Typ.	Max.			
Operating currents							
Standby current for whole device with load $T_j = 25^\circ C$	$I_{S(OFF)_25}^{1)}$	–	5	8	μA	$V_{IN} = LOW$ for $t > t_{RESET}$, $V_S = 13.5V$, $T_j = 25^\circ C$ $V_{OUT} < V_{OUT(OLL)}$	P_6.1
Standby current for whole device with load $T_j = 85^\circ C$	$I_{S(OFF)_85}^{1)}$	–	5	8	μA	$V_{IN} = LOW$ for $t > t_{RESET}$, $V_S = 13.5V$, $T_j = 85^\circ C$ $V_{OUT} < V_{OUT(OLL)}$	P_6.2
Standby current for whole device with load $T_j = 150^\circ C$	$I_{S(OFF)_150}$	–	20	60	μA	$V_{IN} = LOW$ for $t > t_{RESET}$, $V_S = 13.5V$, $T_j = 150^\circ C$ $V_{OUT} < V_{OUT(OLL)}$	P_6.3
Ground current during ON	$I_{GND(ON)}$	–	3	5	mA	$V_{IN} = HIGH$, $t > t_{ON}$	P_6.4
Supply current during open load detection in OFF state	$I_{S(OL)}^{1)}$	–	12	15	mA	$V_{IN} = LOW$ for $t > t_{RESET}$, $V_{OUT} > V_{OUT(OLH)}$	P_6.5
Power stage							
On-State Resistance	$R_{DS(ON)_25}^{1)}$	–	6.8	–	m Ω	$V_{IN} = HIGH$, $T_j = 25^\circ C$, $V_S = 13.5V$, $I_L = +/-13.5A$	P_6.6
On-State Resistance	$R_{DS(ON)_150}$	–	10	12	m Ω	$V_{IN} = HIGH$, $T_j = 150^\circ C$, $V_S = 13.5V$, $I_L = +/-13.5A$	P_6.7
On-State Resistance	$R_{DS(8V)_25}^{1)}$	–	8	–	m Ω	$V_{IN} = HIGH$, $T_j = 25^\circ C$, $V_S = 8V$, $I_L = +/-13.5A$	P_6.8
On-State Resistance	$R_{DS(8V)_150}^{1)}$	–	11.5	15	m Ω	$V_{IN} = HIGH$, $T_j = 150^\circ C$, $V_S = 8V$, $I_L = +/-13.5A$	P_6.9

Electrical Characteristics BTF50060-1TEA
Table 6 Electrical Characteristics: BTF50060-1TEA (cont'd)
 $V_S = 6V$ to $19V$, $T_j = -40^\circ C$ to $150^\circ C$, all voltages with respect to ground, positive current flowing into pin (unless otherwise specified)

Parameter	Symbol	Values			Unit	Note / Test Condition	Number
		Min.	Typ.	Max.			
On-State Resistance at low supply voltage	$R_{DS(UV)_25}^{1)}$	–	10.5	–	m Ω	$V_{IN} = HIGH$, $T_j = 25^\circ C$, $V_S = 4.7V$, $I_L = +/-13.5A$	P_6.10
On-State Resistance at low supply voltage	$R_{DS(UV)_150}$	–	19	25	m Ω	$V_{IN} = HIGH$, $T_j = 150^\circ C$, $V_S = 4.7V$, $I_L = +/-13.5A$	P_6.11
Body diode forward voltage drop ²⁾	$-V_{SD(rev)}^{1)}$	300	700	1000	mV	$V_{IN} = 0V$, $I_L = -13.5A$ (see Figure 13 and Figure 17)	P_6.12
Output leakage current ³⁾	$I_{L(OFF)_25}^{1)}$	–	0.1	1	μA	$T_j = 25^\circ C$, $V_{IN} = LOW$, $V_{OUT} = 0V$	P_6.13
Output leakage current	$I_{L(OFF)_85}^{1)}$	–	0.1	1	μA	$T_j = 85^\circ C$, $V_{IN} = LOW$, $V_{OUT} = 0V$	P_6.14
Output leakage current	$I_{L(OFF)_150}$	–	1	60	μA	$T_j = 150^\circ C$, $V_{IN} = LOW$, $V_{OUT} = 0V$	P_6.15

Switching a resistive load

Slew rate 30% to 70% V_S	$(dV/dt)_{ON}^{1)}$	22	43	108	V/ μs	$R_L = 1\Omega$, $V_S = 13.5V$ (see Figure 10 and Figure 11 for definitions)	P_6.16
Slew rate 70% to 30% V_S	$(dV/dt)_{OFF}^{1)}$	-90	-31	-13	V/ μs		P_6.17
Slew rate matching $(dV/dt)_{ON} - (dV/dt)_{OFF} $	$\Delta dV/dt^{1)}$	-5	12	30	V/ μs		P_6.18
Turn ON time to 90% V_S	t_{ON}	–	0.35	1.0	μs		P_6.19
Turn OFF time to 10% V_S	t_{OFF}	–	0.85	1.5	μs		P_6.20
Turn ON/OFF matching	$t_{ON} - t_{OFF}$	-1.15	-0.5	-0.25	μs		P_6.21
Wake up delay time	$t_{wake}^{1)}$	–	2	–	μs		P_6.62
Turn ON rise time 10% to 90% V_S	t_r	0.1	0.25	0.49	μs		P_6.22
Turn OFF fall time 90% to 10% V_S	t_f	0.12	0.35	0.83	μs		P_6.23

Switching an inductive load

Source to Drain Smart Clamping voltage ⁴⁾	$V_{SD(CL)_25}^{1)}$	32	40	–	V	$T_j = 25^\circ C$, $I_L = 40mA$,	P_6.26
Source to Drain Smart Clamping voltage	$V_{SD(CL)_150}^{1)}$	40	48	–	V	$T_j = 150^\circ C$, $I_L = 13.5A$,	P_6.27

Input circuitry

LOW level input voltage	$V_{IN(L)}$	-0.3	–	0.8	V	–	P_6.28
-------------------------	-------------	------	---	-----	---	---	--------

Electrical Characteristics BTF50060-1TEA
Table 6 Electrical Characteristics: BTF50060-1TEA (cont'd)
 $V_S = 6V$ to $19V$, $T_j = -40^\circ C$ to $150^\circ C$, all voltages with respect to ground, positive current flowing into pin (unless otherwise specified)

Parameter	Symbol	Values			Unit	Note / Test Condition	Number
		Min.	Typ.	Max.			
HIGH level input voltage	$V_{IN(H)}$	2.0	–	6	V	–	P_6.29
Input voltage hysteresis	$\Delta V_{IN}^{1)}$	–	200	–	mV	–	P_6.30
Input pull down resistor	R_{IN}	50	100	200	k Ω	–	P_6.31
Protection							
Short circuit shutdown threshold	$I_{L(SC)}$	60	75	95	A	$8V < V_S < 19V$	P_6.32
Short circuit shutdown threshold at low supply voltage	$I_{L(SC)LV}^{1)}$	10	–	$I_{L(SC)}$	A	$4.7V < V_S < 8V$	P_6.33
Thermal shutdown temperature	T_{jt}	150	175 ¹⁾	200 ¹⁾	$^\circ C$	–	P_6.34
Latch reset time	$t_{RESET}^{1)}$	40	55	80	ms	$V_{IN} = LOW$ $6V < V_S < 28V$	P_6.35
Output leakage current while GND disconnected ⁵⁾	$I_{OUT(GND)}^{1)}$	0	0.5	1.0	mA	$V_S = V_{S(EXT)}$, GND pin disconnected	P_6.40
Over voltage protection of logic IC	$V_{Z(IC)}$	45	50	–	V	$I_{GND} = 5mA$	P_6.41
Sense Output							
Sense current steepness (reciprocal)	k_{IS}	10.5	13	15	k	see Equation (6) $I_{L1} = 13.5A$,	P_6.42
k_{IS} temperature variance	$\Delta k_{IS(Temp)}^{1)}$	-2	0	+2	%	$I_{L2} = 0A$, $V_S - V_{IS} > 3V$	P_6.43
Sense current $I_L = I_{L1}$	$I_{IS(L1)}$	0.95	1.28	1.88	mA	$I_L = 13.5A$, $V_S - V_{IS} > 3V$	P_6.44
Sense current offset	$I_{IS(OFFSET)}$	50	240	600	μA	$V_S - V_{IS} > 3V$	P_6.46
Sense current offset temperature variance	$\Delta I_{IS(OFFSET)}^{1)}$	-100	0	100	μA	see Equation (8)	P_6.47
Leakage Current at sense output	$I_{IS(LL)}$	0	0.1	1	μA	$V_{IN} = LOW$ for $t > t_{RESET}$, $V_{OUT} < V_{OUT(OLL)}$	P_6.48
Fault signal current at sense output	$I_{IS(fault)}$	6.5	7.5	9	mA	⁶⁾ $V_S - V_{IS} > 3V$	P_6.49
Current sense settling time for turn ON to 90% I_{IS}	$t_{sIS(ON)}^{1)}$	0	1	3	μs	$V_S = 13.5V$, $R_L = 1.0\Omega$,	P_6.50
Current sense settling time for turn OFF to 10% I_{IS}	$t_{sIS(OFF)}^{1)}$	0	1	3	μs	$R_{IS} = 1.0k\Omega$, $C_{SENSE} < 100pF$,	P_6.51
Current sense settling time matching	$t_{sIS(ON)}^{-}$ $t_{sIS(OFF)}^{1)}$	-0.5	0	0.5	μs	See Figure 21	P_6.52

Table 6 Electrical Characteristics: BTF50060-1TEA (cont'd)
 $V_S = 6V$ to $19V$, $T_j = -40^\circ C$ to $150^\circ C$, all voltages with respect to ground, positive current flowing into pin (unless otherwise specified)

Parameter	Symbol	Values			Unit	Note / Test Condition	Number
		Min.	Typ.	Max.			
Current sense settling time after changes of the load current I_L	$t_{sIS(LC)}^{1)}$	0	1	2	μs	$V_{IN} = HIGH$, $I_L = 1A \leftrightarrow 50A$ $R_{IS} = 1.0k\Omega$, $C_{SENSE} < 100pF$, See Figure 21	P_6.53
Turn ON current sense settling time to $I_{IS(fault)}$ in case of short circuit	$t_{sIS(FAULT)}^{1)}$	0	1	3	μs	$R_{IS} = 1.0k\Omega$, $C_{SENSE} < 100pF$, See Figure 16	P_6.54

Open load at OFF

Output voltage threshold for open load detection in OFF state	$V_{OUT(OLH)}$	5	5.5	6	V	$V_{IN} = LOW$, $t > t_{RESET}$, $V_S = 13.5V$, see Figure 23 , Figure 43 and Figure 44	P_6.55
Output voltage threshold for resetting open load detection in OFF state	$V_{OUT(OLL)}$	4.5	5	5.5			P_6.56
Output voltage hysteresis for open load detection in OFF state	$\Delta V_{OUT(OL)}^{1)}$	–	500	–	mV		P_6.57
Intrinsic output pull-down resistance	$R_{OUT(GND)}^{1)}$	–	450	–	k Ω	$V_{OUT} = 4.5V$, $V_{IN} = LOW$, for $t > t_{RESET}$	P_6.63

Undervoltage shutdown and restart

Undervoltage turn ON voltage	$V_{S(UV)ON}$	–	4.4	4.7	V	V_S increasing, $V_{IN} = HIGH$	P_6.58
Undervoltage turn OFF voltage	$V_{S(UV)OFF}$	–	4.1	4.4	V	V_S decreasing, $V_{IN} = HIGH$	P_6.59
Undervoltage turn ON/OFF hysteresis	$\Delta V_{S(UV)}^{1)}$	–	0.25	–	V	$V_{S(UV)ON}$ - $V_{S(UV)OFF}$, $V_{IN} = HIGH$	P_6.60
Undervoltage restart delay time	$t_{delay(UV)}$	4	6	8	ms	$V_{IN} = HIGH$	P_6.61

1) Not subject to production test, specified by design

2) Please note - during ON state, the output voltage drop in inverse current operation is defined by $V_{SD} = R_{DS(ON)} \times I_L$

3) See [Figure 28](#) for typical temperature dependency.

4) See [Figure 33](#) for typical temperature dependency.

5) All pins disconnected except for V_S and OUT

6) Valid after over temperature or short circuit to ground until reset ($t > t_{RESET}$, $V_{IN} = LOW$, or undervoltage detection) or during detection of open load in OFF state.

6.2 Parameter dependencies

6.2.1 Power Stage

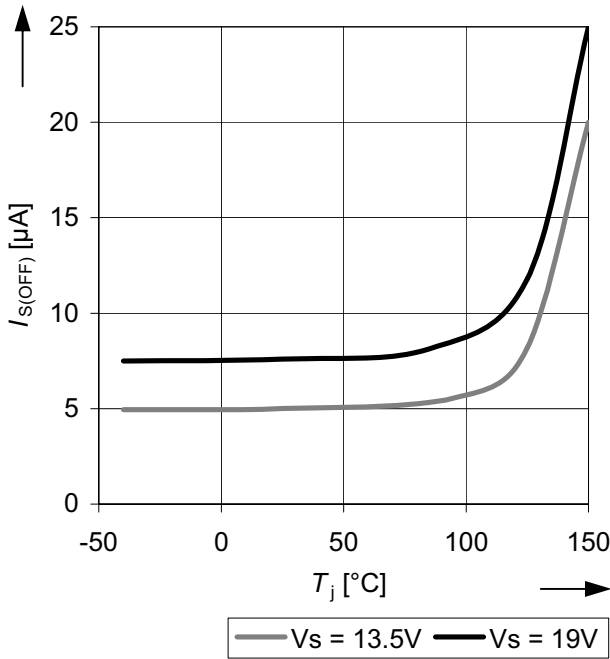

Figure 25 Typical standby current $I_{S(OFF)}$ as a function of the junction temperature T_j
 $V_S = 13.5V$, $V_{IN} = LOW$ for $t > t_{RESET}$

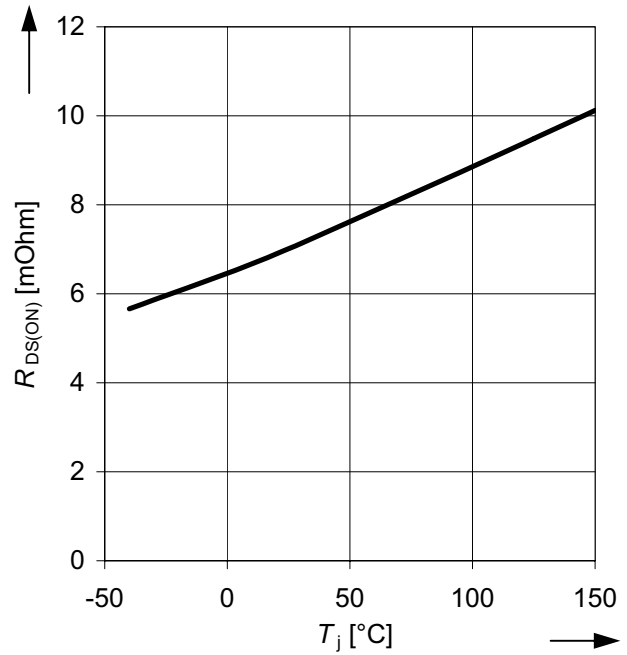

Figure 26 Typical ON state resistance $R_{DS(ON)}$ as a function of the junction temperature T_j
 $V_S = 13.5V$, $I_L = 13.5A$, $V_{IN} = HIGH$

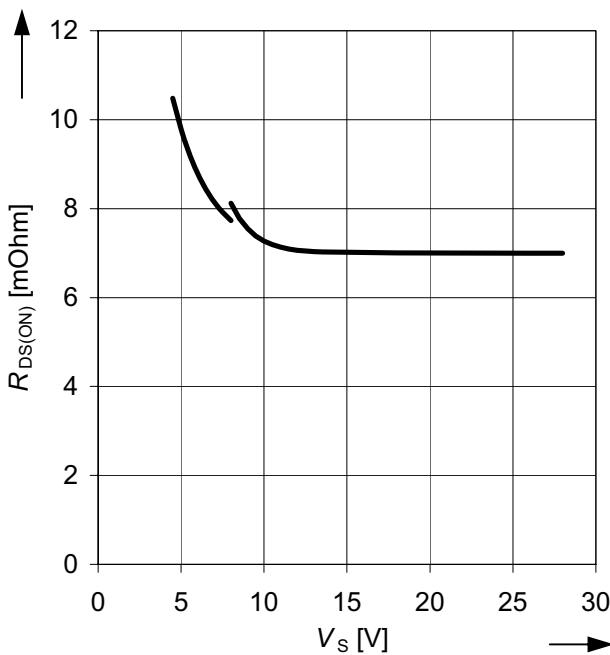

Figure 27 Typical ON state resistance $R_{DS(ON)}$ as a function of the supply voltage V_S
 $T_j = 25°C$, $I_L = 13.5A$, $V_{IN} = HIGH$

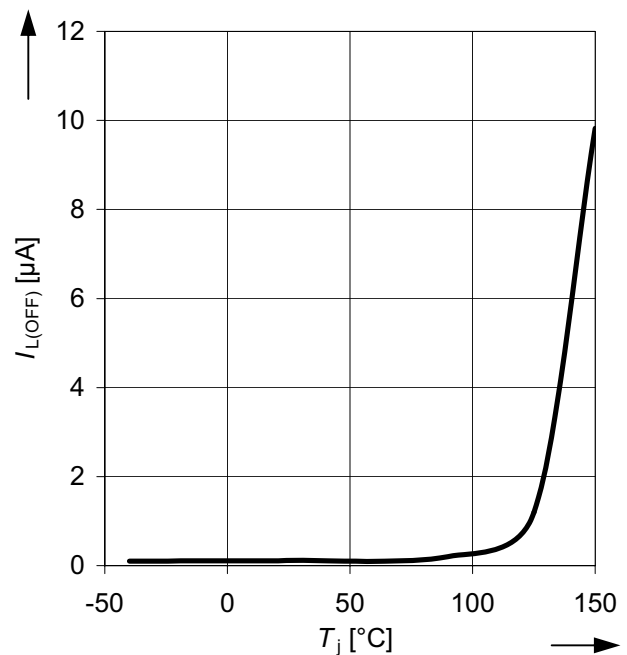

Figure 28 Typ. output leakage current $I_{L(OFF)}$ as a function of the junction temperature T_j
 $V_S = 13.5V$, $V_{IN} = LOW$

Electrical Characteristics BTF50060-1TEA

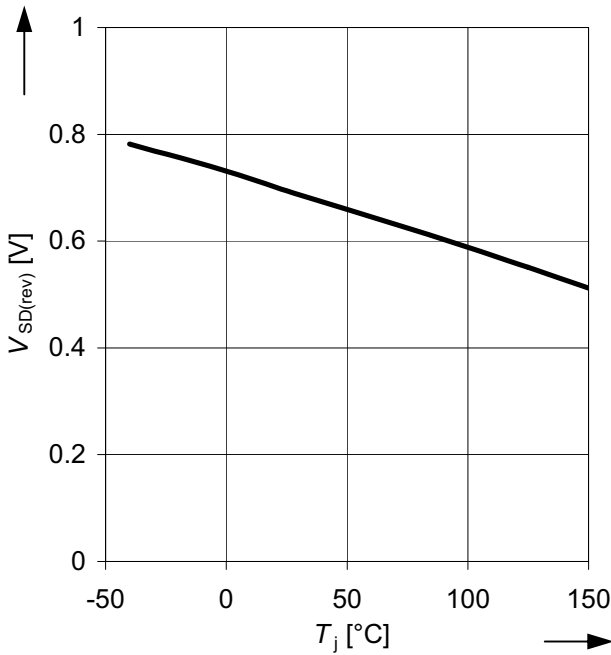

Figure 29 Typical body diode forward voltage drop $-V_{SD(rev)}$ as a function of the junction temperature T_j
 $I_L = -4A, V_{IN} = LOW$

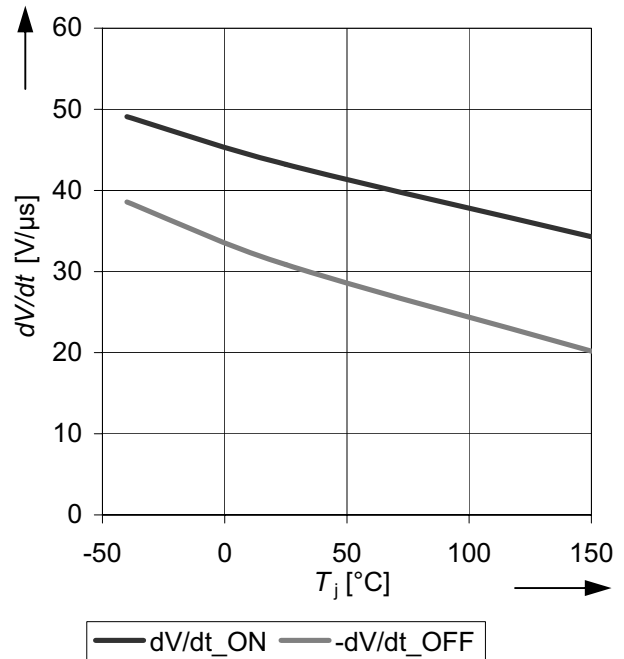

Figure 30 Typical slew rate for turn ON $(dV/dt)_{ON}$ and turn OFF $-(dV/dt)_{OFF}$ as a function of the junction temperature T_j
 $R_L = 1\Omega, V_S = 13.5V, 30\% \Leftrightarrow 70\% V_S$

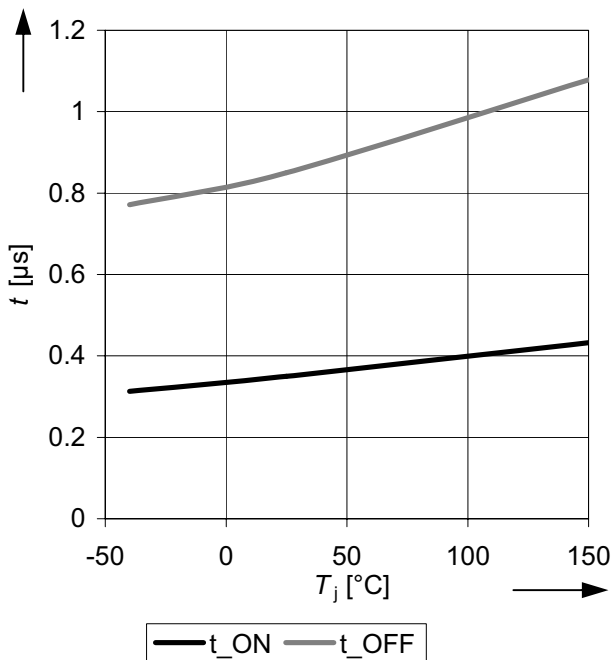

Figure 31 Typical turn ON time t_{ON} and turn OFF time t_{OFF} as a function of the junction temperature T_j
 $R_L = 1\Omega, V_S = 13.5V,$

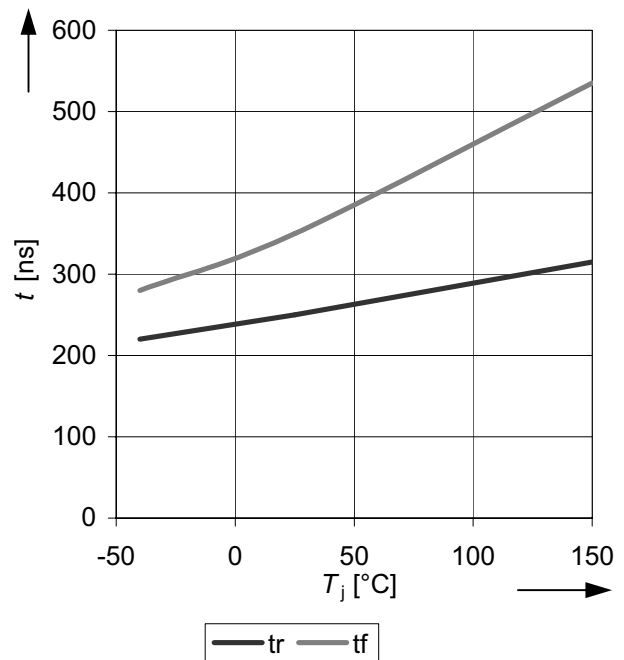

Figure 32 Typical turn ON rise time t_r and turn OFF fall time t_f as a function of the junction temperature T_j
 $R_L = 1\Omega, V_S = 13.5V, 10\% \Leftrightarrow 90\% V_S$

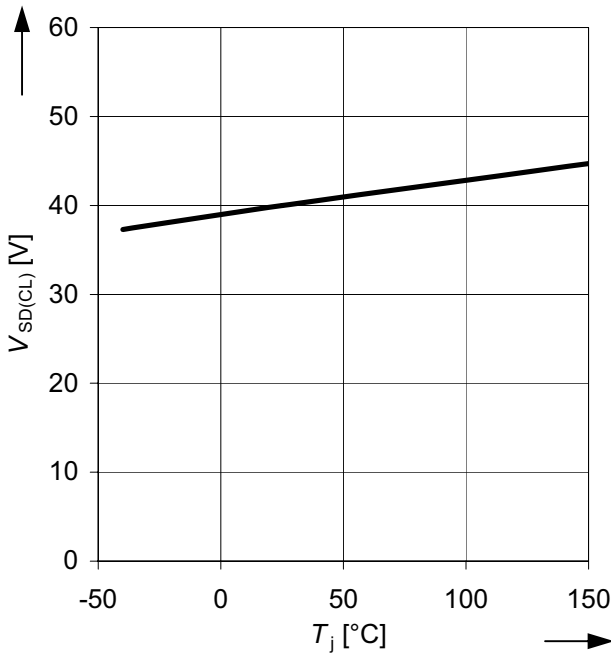

Figure 33 Source to Drain Smart Clamping voltage $V_{SD(CL)}$ as a function of the junction temperature T_j
 $I_L = 40\text{mA}$, $V_{IN} = \text{LOW}$

6.2.2 Input Circuit

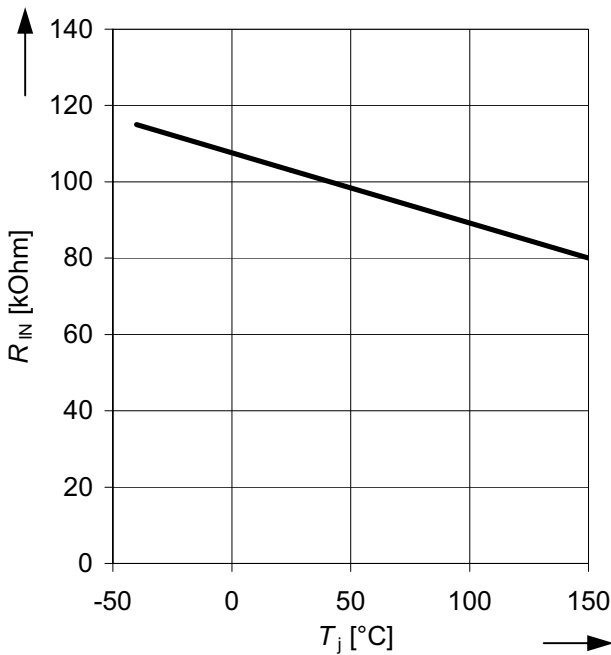

Figure 34 Typ. input pull down resistor R_{IN} as a function of the junction temperature T_j

6.2.3 Protection Functions

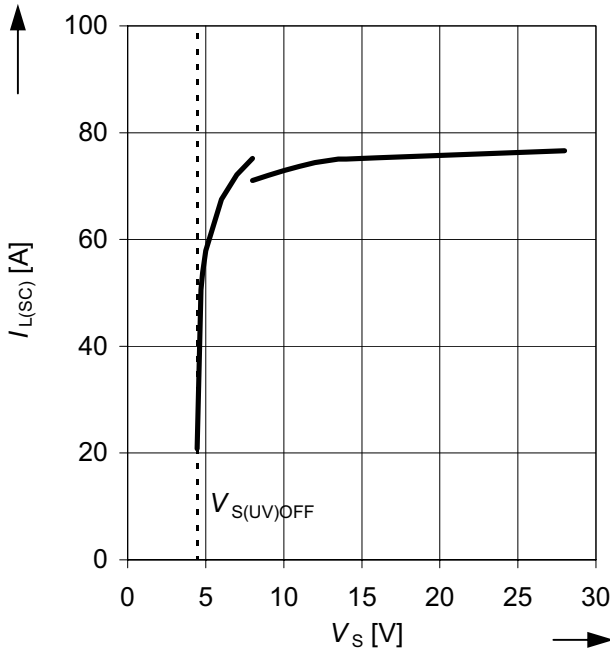

Figure 35 Typical short circuit shutdown threshold as a function of the supply voltage V_s ; $T_j = 25^\circ\text{C}$

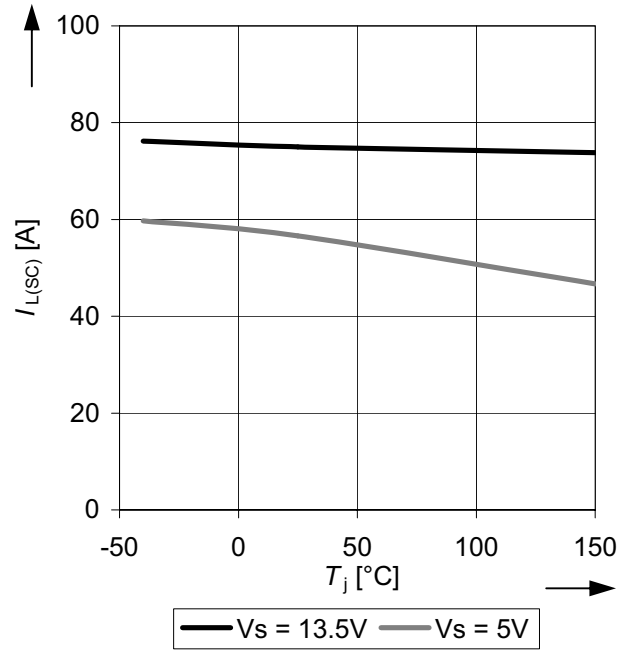

Figure 36 Typical short circuit shutdown threshold as a function of the junction temperature T_j ; $V_s = 13.5\text{V}$

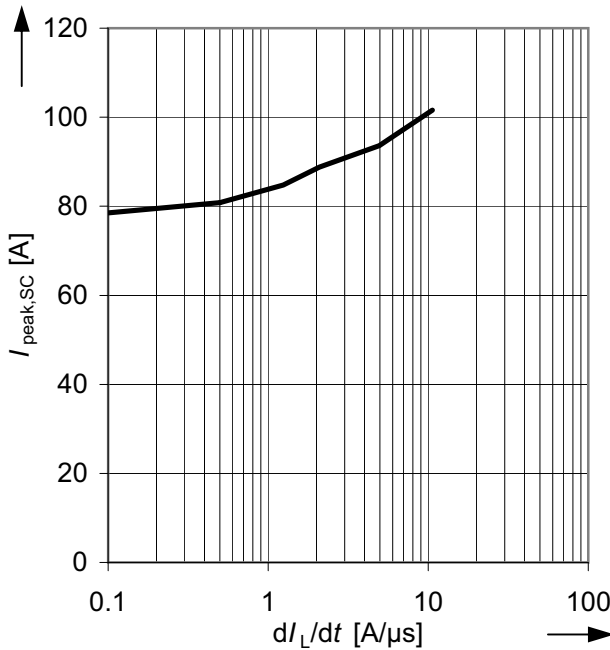

Figure 37 Typical short circuit overshooting as a function of the dI_{sc}/dt (device is in ON state when short circuit appears) $T_j = 25^\circ\text{C}$

6.2.4 Diagnosis Functions

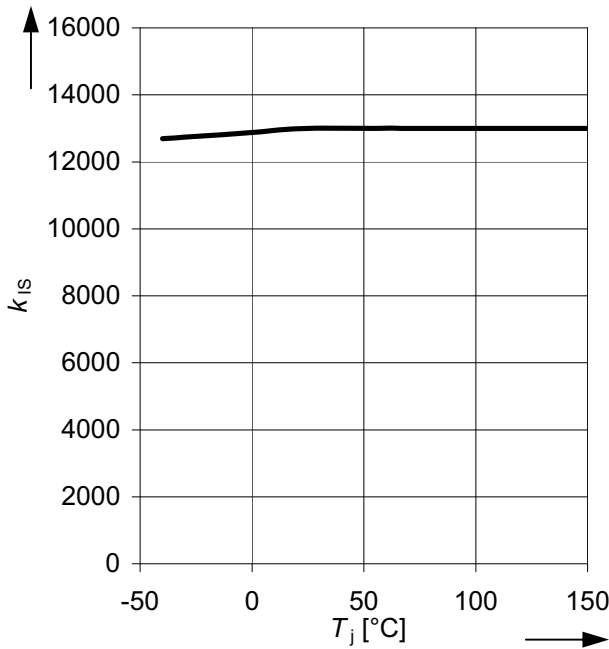

Figure 38 Typical sense current slope k_{IS} as a function of the junction temperature T_j
 $V_S = 13.5V, I_{L1}=13.5A, I_{L2}=0A, V_{IN}=HIGH$

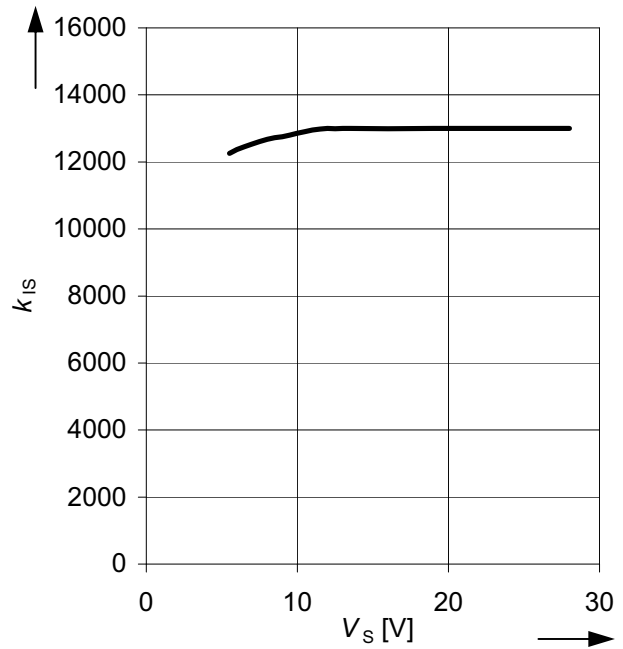

Figure 39 Typical sense current slope k_{IS} as a function of the supply voltage V_S
 $T_j = 25^\circ C, I_{L1}=13.5A, I_{L2}=0A, V_{IN}=HIGH$

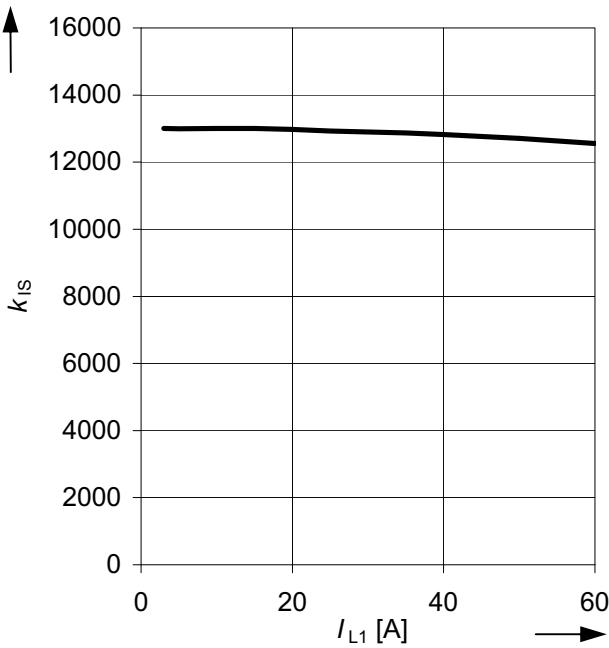

Figure 40 Typical sense current slope k_{IS} as a function of the load current I_{L1}
 $V_S = 13.5V, T_j = 25^\circ C, I_{L2}=0A, V_{IN} = HIGH$

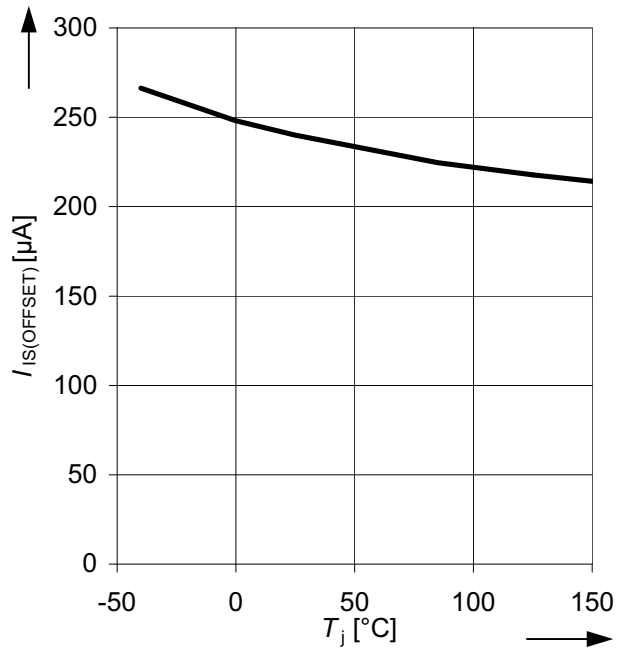

Figure 41 Typical sense current offset $I_{IS(OFFSET)}$ as a function of the junction temperature T_j
 $V_S = 13.5V, V_{IN} = HIGH$

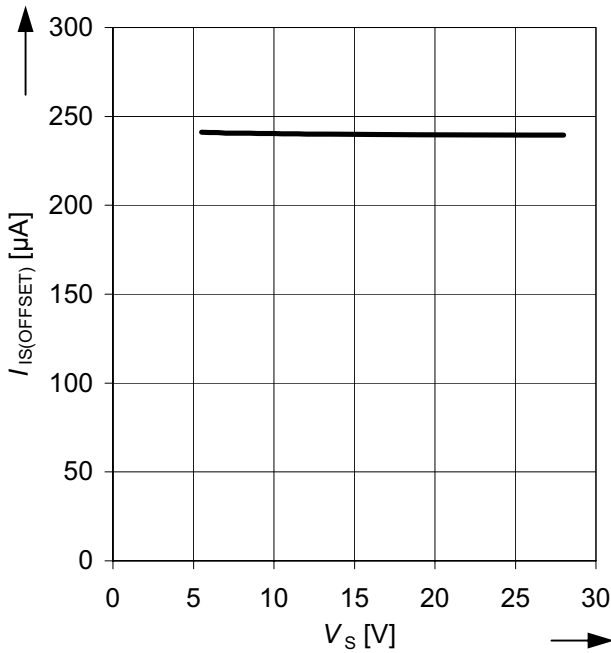

Figure 42 Typical sense current offset $I_{IS(OFFSET)}$ as a function of the supply voltage V_S
 $T_j = 25^\circ\text{C}$, $V_{IN} = \text{HIGH}$

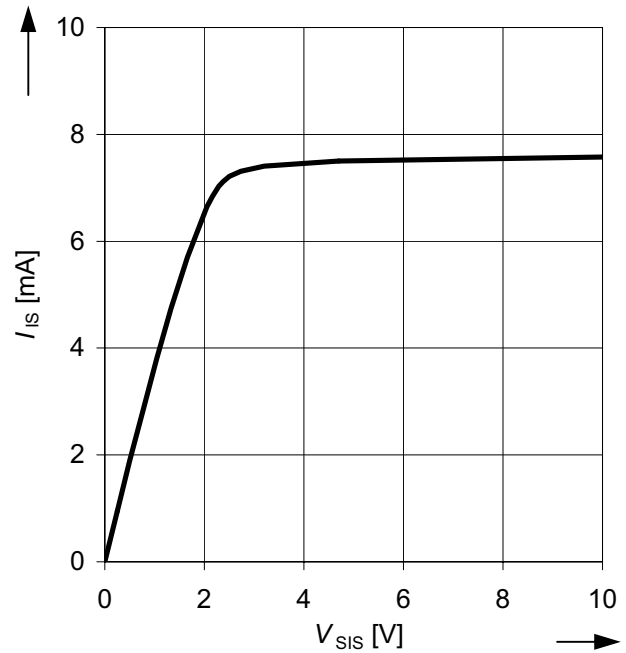

Figure 42 Typical fault current $I_{IS(fault)}$ at the sense output as a function of the voltage $V_{SIS} = V_S - V_{IS}$
 $V_S = 13.5\text{V}$, $V_{IN} = \text{HIGH}$

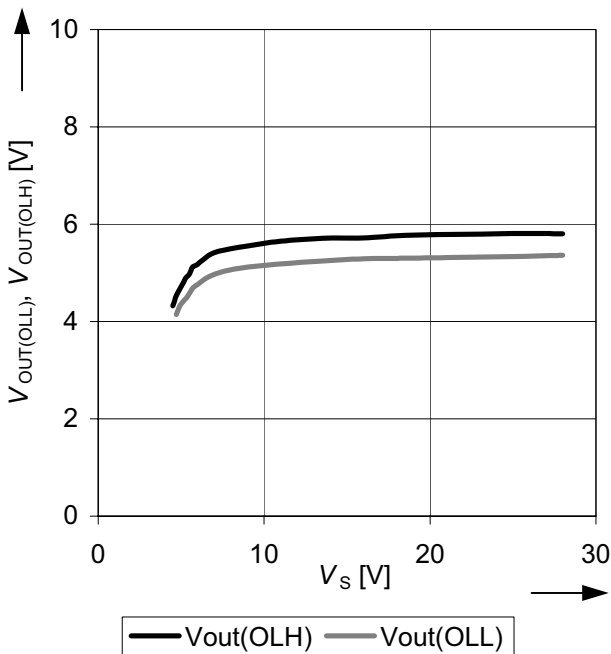

Figure 43 Typical output voltage thresholds for open load detection during OFF $V_{OUT(OLH)}$ and $V_{OUT(OLL)}$ as a function of the supply voltage V_S
 $T_j = 25^\circ\text{C}$

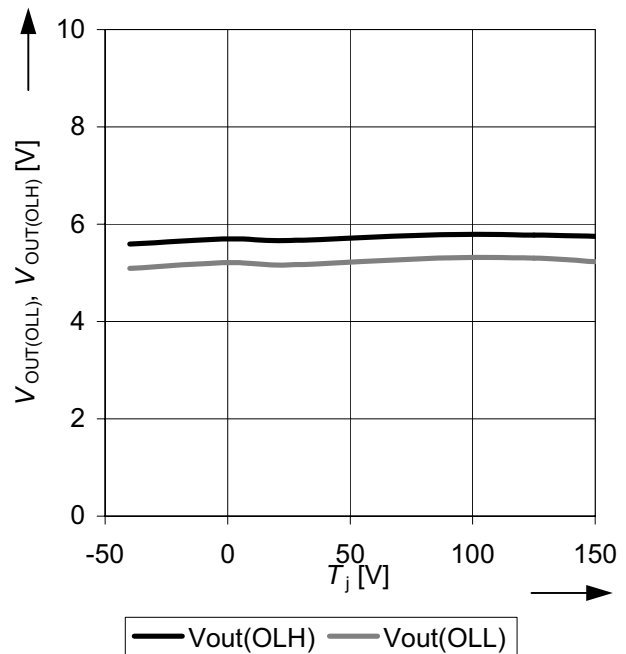

Figure 44 Typical output voltage thresholds for open load detection during OFF $V_{OUT(OLH)}$ and $V_{OUT(OLL)}$ as a function of the junction temperature T_j
 $V_S = 13.5\text{V}$

7 Application Information

Note: The following information is given as a hint for the implementation of the device only and shall not be regarded as a description or warranty of a certain functionality, condition or quality of the device.

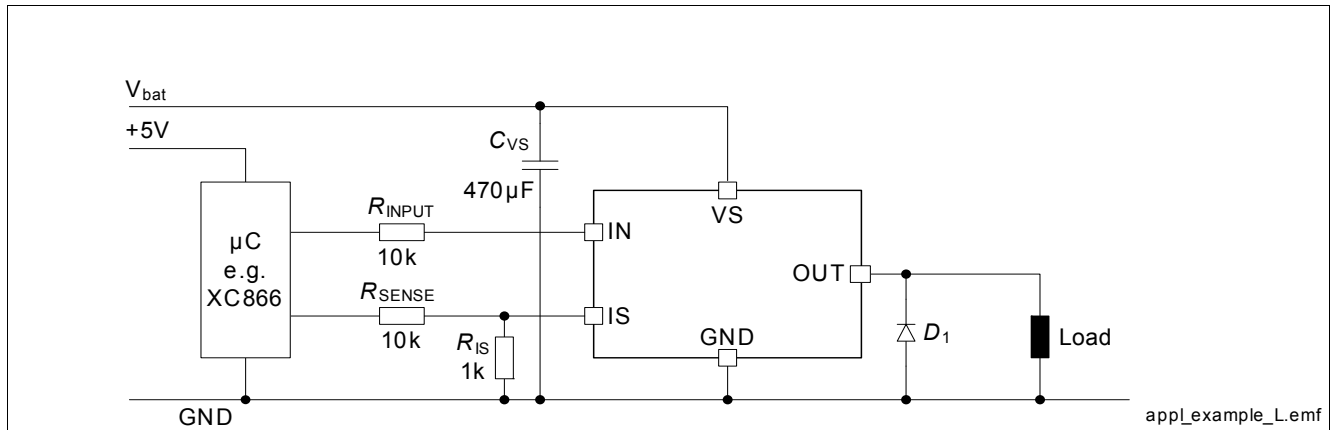

Figure 45 Application Diagram for switching an inductive load without external circuitry supporting open load detection in OFF state

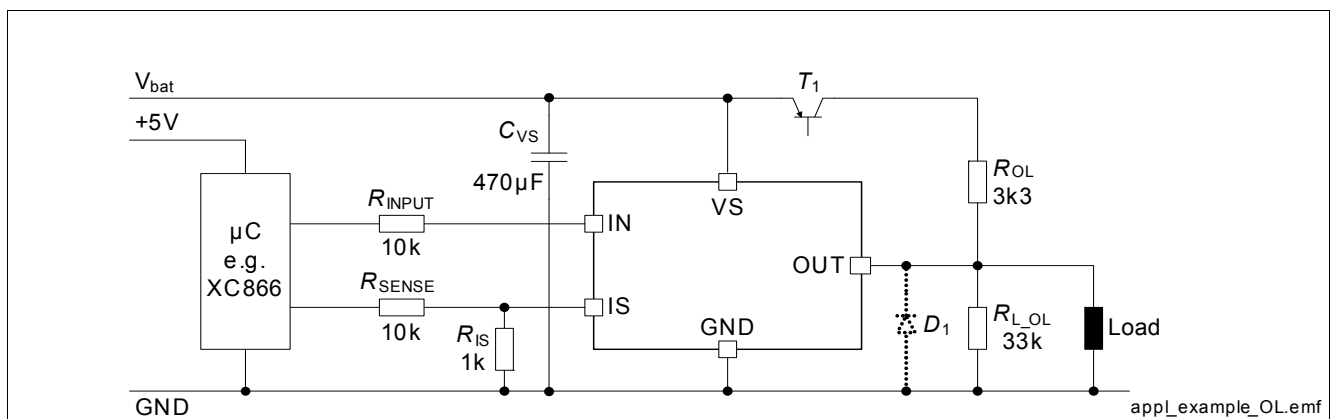

Figure 46 Application Diagram with external circuitry supporting open load detection in OFF state

Note: This are very simplified examples of an application circuit. The function must be verified in the real application.

Table 7 Typical Application Parameter¹⁾

Parameter	Symbol	Typical Values	Note / Condition
Range of typical PWM frequencies	f_{PWM}	0 Hz ... 33 kHz	duty cycle = 0%, 10% ... 90%
Nominal Load Current	$I_{L(NOM)}$	16.5 A	$T_A = 85^\circ\text{C}$, $T_j < 150^\circ\text{C}$, $R_{thJA} = 22\text{K/W}$ DC operation or $f_{PWM} < 1\text{kHz}$; $V_S = 19\text{V}$
Typical load current at 10 kHz	$I_{L(10\text{kHz})}$	11 A	$T_A = 85^\circ\text{C}$, $T_j < 150^\circ\text{C}$, $R_{thJA} = 22\text{K/W}$ $f_{PWM} = 10\text{kHz}$, duty cycle = 95%, $V_S = 19\text{V}$
Typical load current at 25 kHz	$I_{L(25\text{kHz})}$	7 A	$T_A = 85^\circ\text{C}$, $T_j < 150^\circ\text{C}$, $R_{thJA} = 22\text{K/W}$ $f_{PWM} = 25\text{kHz}$, duty cycle = 95%, $V_S = 19\text{V}$,

1) Values are calculated and not subject to production test.

Table 8 Bill of Material

Reference	Value	Purpose
R_{INPUT}	10 k Ω	Protection of the μC during overvoltage and reverse battery condition
R_{SENSE}	10 k Ω	Protection of the μC during overvoltage and reverse battery condition
R_{IS}	1 k Ω	Sense resistor. Shunt resistor for measuring I_{IS} by the μC 's AD converter.
C_{VS}	470 μF	Capacitor buffering the supply voltage
Switching an inductive load		
D_1		Freewheeling diode for commutation of load current. Depending on load current and thermal boundary conditions, it may be necessary to use active freewheeling by a MOSFET, instead of the diode.
External circuitry supporting open load at OFF detection		
T_1	BC807	Switches the supply voltage for activation / deactivation of Open Load at OFF detection
R_{OL}	3.3k Ω	Pull up resistor for Open Load detection in OFF state
$R_{\text{L_OL}}$	33k Ω	Pull down resistor for deactivating Open Load detection in OFF state

7.1 Further Application Information

- Please contact us for information regarding the pin FMEA
- For further information you may visit <http://www.infineon.com/>

μ

8 Package Outlines and Parameters

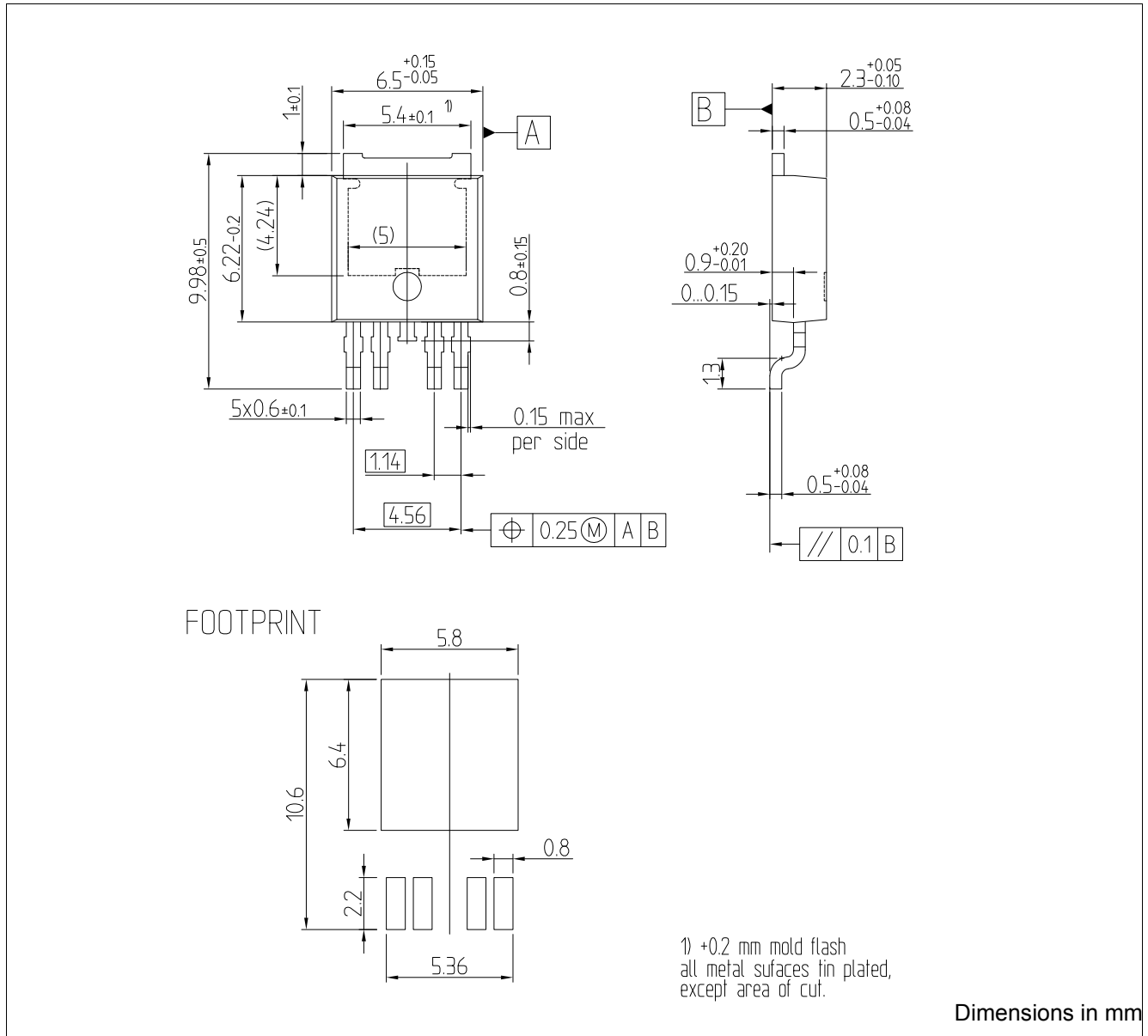

Figure 47 PG-T0252-5-11

Green Product (RoHS compliant)

To meet the world-wide customer requirements for environmentally friendly products and to be compliant with government regulations the device is available as a green product. Green products are RoHS-Compliant (i.e. Pb-free finish on leads and suitable for Pb-free soldering according to IPC/JEDEC J-STD-020).

Table 9

Parameter	Value
JeDEC humidity category acc. J-STD-020-D	MSL3
JeDEC classification temperature acc. J-STD-020-D	260°C

9 Revision History

Revision	Date	Changes
DS V1.2	2011-09-01	<p>Package name changed from PG-TO252-5-311 to PG-TO252-5-11</p> <p>P_4.17 and P_4.18 Reference updated to ANSI/ESDA/JEDEC JS-001-2010</p> <p>P_6.12 Footnote 2): Replacing $V_{SD(inv)}$ by V_{SD} in formula.</p> <p>P_6.26 $V_{SD(CL)_25}$, P_6.27 $V_{SD(CL)_150}$ and Figure 33 "Output voltage drop limitation" renamed to "Source to Drain Smart Clamping voltage"</p>
DS V1.1	2011-05-26	<p>Chapter 4.1 Footnote 4) splitted. Footnote 6) added.</p> <p>Equation (7) and Equation (8) corrected. (150°C)</p> <p>P_6.3 $I_{S(OFF)_150}$ condition set to $V_S = 13.5V$</p> <p>P_6.16 $(dV/dt)_{ON}$, P_6.17 $(dV/dt)_{OFF}$ and P_6.18 $\Delta dV/dt$ not subject to production test; all values changed. Figure 30, Figure 31 and Figure 32 added.</p> <p>P_6.46 $I_{S(OFFSET)}$, P_6.44 $I_{S(L1)}$ typical value and maximum limit changed.</p> <p>Figure 41 and Figure 42 adapted.</p> <p>Figure 40 "Typical leakage current $I_{S(LL)}$ at the sense output as a function of the junction temperature T_j" and Figure 41 "Typical leakage current $I_{S(LL)}$ at the sense output as a function of the supply voltage V_S" removed.</p>
DS V1.0	2010-06-24	Initial datasheet version.

Edition 2011-09-01

**Published by
Infineon Technologies AG
81726 Munich, Germany**

**© 2011 Infineon Technologies AG
All Rights Reserved.**

Legal Disclaimer

The information given in this document shall in no event be regarded as a guarantee of conditions or characteristics. With respect to any examples or hints given herein, any typical values stated herein and/or any information regarding the application of the device, Infineon Technologies hereby disclaims any and all warranties and liabilities of any kind, including without limitation, warranties of non-infringement of intellectual property rights of any third party.

Information

For further information on technology, delivery terms and conditions and prices, please contact the nearest Infineon Technologies Office (www.infineon.com).

Warnings

Due to technical requirements, components may contain dangerous substances. For information on the types in question, please contact the nearest Infineon Technologies Office.

Infineon Technologies components may be used in life-support devices or systems only with the express written approval of Infineon Technologies, if a failure of such components can reasonably be expected to cause the failure of that life-support device or system or to affect the safety or effectiveness of that device or system. Life support devices or systems are intended to be implanted in the human body or to support and/or maintain and sustain and/or protect human life. If they fail, it is reasonable to assume that the health of the user or other persons may be endangered.

单击下面可查看定价，库存，交付和生命周期等信息

[>>Infineon\(英飞凌\)](#)