

# 1.5 AMP POSITIVE ADJUSTABLE VOLTAGE REGULATOR APPROVED TO DESC DRAWING 7703401



**Three Terminal, Precision Adjustable  
 Positive Voltage Regulator In Hermetic  
 Style Packages (LM117)**

## FEATURES

- Similar To Industry Standard LM117
- Approved To DESC Standardized Military Drawing Number 7703401
- Built In Thermal Overload Protection
- Short Circuit Current Limiting
- Available In Six Package Styles

## DESCRIPTION

These three terminal positive regulators are supplied in hermetically sealed packages. All protective features are designed into the circuit, including thermal shutdown, current-limiting, and safe-area control. With heat sinking, these devices can deliver up to 1.5 amps of output current. The LCC-20 device is limited to .5 amps. The unit also features output voltages that can be fixed from 1.2 volts to 37 volts using external resistors.

## ABSOLUTE MAXIMUM RATINGS $T_c @ 25^\circ\text{C}$

Power Dissipation

Case 2 . . . . .	1.1 W
Case-All Others. . . . .	20 W

Input - Output Voltage Differential . . . . . 40 V

Operating Junction Temperature Range . . . . . - 55°C to + 150°C

Storage Temperature Range . . . . . - 65°C to + 150°C

Lead Temperature (Soldering 10 seconds) . . . . . 300°C

Thermal Resistance, Junction to Case:

Case 2, LCC-20 . . . . .	17°C/W
Case U & M, TO-257 (Isol) and SMD-3 . . . . .	4.2°C/W
Case T&N, TO-257 (Non-Isol) and SMD-1 . . . . .	3.5°C/W
Case Y, TO-3. . . . .	3.0°C/W

Maximum Output Current:

Case 2 . . . . .	.5 A
Case-All Others. . . . .	1.5 A

Recommended Operating Conditions:

Output Voltage Range . . . . .	1.2 to 37 VDC
Ambient Operating Temperature Range ( $T_A$ ). . . . .	- 55°C to + 125°C
Input Voltage Range . . . . .	4.25 to 41.25 VDC

3.5



**ELECTRICAL CHARACTERISTICS** -55°C T<sub>A</sub> 125°C, I<sub>L</sub> = 8mA (unless otherwise specified)

**OM1320NTM, OM1320STM, OM1320NKM, OM1320SMM, OM1320NMM**

Parameter	Symbol	Test Conditions	Min.	Max.	Unit
Reference Voltage	V <sub>REF</sub>	V <sub>DIFF</sub> = 3.0V, T <sub>A</sub> = 25°C	1.20	1.30	V
		V <sub>DIFF</sub> = 3.3V	• 1.20	1.30	
		V <sub>DIFF</sub> = 40V	• 1.20	1.30	
Line Regulation (Note 1)	R <sub>LINE</sub>	3.0V V <sub>DIFF</sub> 40V, V <sub>out</sub> = V <sub>ref</sub> , T <sub>A</sub> = 25°C	-9	9	mV
		3.3V V <sub>DIFF</sub> 40V, V <sub>out</sub> = V <sub>ref</sub>	• -23	23	
Load Regulation (Note 1)	R <sub>LOAD</sub>	V <sub>DIFF</sub> = 3.0V, 10mA I <sub>L</sub> 1.5A, T <sub>A</sub> = 25°C	-15	15	mV
		V <sub>DIFF</sub> = 3.3V, 10mA I <sub>L</sub> 1.5A	• -15	15	
		V <sub>DIFF</sub> = 40V, 10mA I <sub>L</sub> 300mA, T <sub>A</sub> = 25°C	-15	15	
		V <sub>DIFF</sub> = 40V, 10mA I <sub>L</sub> 195mA	• -15	15	
Thermal Regulation	V <sub>RTH</sub>	V <sub>in</sub> = 14.6V, I <sub>L</sub> = 1.5A P <sub>d</sub> = 20 Watts, t = 20 ms, T <sub>A</sub> = 25°C	-16	16	mV
Ripple Rejection (Note 2)	R <sub>N</sub>	f = 120 Hz, V <sub>out</sub> = V <sub>ref</sub> C <sub>Adj</sub> = 10 μF	• 66		dB
Adjustment Pin Current	I <sub>Adj</sub>	V <sub>DIFF</sub> = 3.0V, T <sub>A</sub> = 25°C V <sub>DIFF</sub> = 3.3V V <sub>DIFF</sub> = 40V		100 100 100	μA
Adjustment Pin Current Change	I <sub>Adj</sub>	V <sub>DIFF</sub> = 3.0V, 10mA I <sub>L</sub> 1.5A, T <sub>A</sub> = 25°C	-5	5	μA
		V <sub>DIFF</sub> = 3.3V, 10mA I <sub>L</sub> 1.5A	• -5	5	
		V <sub>DIFF</sub> = 40V, 10mA I <sub>L</sub> 300mA, T <sub>A</sub> = 25°C	• -5	5	
		V <sub>DIFF</sub> = 40V, 10mA I <sub>L</sub> 195mA	• -5	5	
		3.0V V <sub>DIFF</sub> 40V, T <sub>A</sub> = 25°C	-5	5	
		3.3V V <sub>DIFF</sub> 40V	• -5	5	
Minimum Load Current	I <sub>Lmin</sub>	V <sub>DIFF</sub> = 3.0V, V <sub>OUT</sub> = 1.4V (forced)		5.0	mA
		V <sub>DIFF</sub> = 3.3V, V <sub>OUT</sub> = 1.4V (forced)	•	5.0	
		V <sub>DIFF</sub> = 40V, V <sub>OUT</sub> = 1.4V (forced)	•	5.0	
Current Limit (Note 2)	I <sub>CL</sub>	V <sub>DIFF</sub> = 15V	• 1.5	3.5	A
		V <sub>DIFF</sub> = 40V, T <sub>A</sub> = 25°C	0.18	1.5	

**Notes:**

1. Load and Line Regulation are specified at a constant junction temperature. Pulse testing with low duty cycle is used. Changes in output voltage due to heating effects must be taken into account separately.
2. If not tested, shall be guaranteed to the specified limits.
3. The • denotes the specifications which apply over the full operating temperature range.

3.5

PART NUMBER DESIGNATOR		
Standard Military Drawing Number	Omnirel Part Number	Omnirel Package Designation
7703401M 7703401U 7703401T 7703401Y 7703401N 77034012	OM1320SMM OM1320STM OM1320NTM OM1320 NKM OM1320NMM OM1320N2M	SMD-3 TO-257 (Isolated) TO-257 (non-Isolated) TO-3 SMD-1 LCC-20



**ELECTRICAL CHARACTERISTICS** -55°C T<sub>A</sub> 125°C, I<sub>L</sub> = 8mA (unless otherwise specified)

**OM1320N2M**

Parameter	Symbol	Test Conditions	Min.	Max.	Unit
Reference Voltage	V <sub>REF</sub>	V <sub>DIFF</sub> = 3.0V, T <sub>A</sub> = 25°C V <sub>DIFF</sub> = 3.3V V <sub>DIFF</sub> = 40V	1.20 • 1.20 • 1.20	1.30 1.30 1.30	V
Line Regulation (Note 1)	R <sub>LINE</sub>	3.0V V <sub>DIFF</sub> 40V, V <sub>out</sub> = V <sub>ref</sub> , T <sub>A</sub> = 25°C 3.3V V <sub>DIFF</sub> 40V, V <sub>out</sub> = V <sub>ref</sub>	-9 • -23	9 23	mV
Load Regulation (Note 1)	R <sub>LOAD</sub>	V <sub>DIFF</sub> = 3.0V, 10mA I <sub>L</sub> .5A, T <sub>A</sub> = 25°C V <sub>DIFF</sub> = 3.3V, 10mA I <sub>L</sub> .5A V <sub>DIFF</sub> = 40V, 10mA I <sub>L</sub> 150mA, T <sub>A</sub> = 25°C V <sub>DIFF</sub> = 40V, 10mA I <sub>L</sub> 100mA	-15 • -15 -15 • -15	15 15 15 15	mV
Thermal Regulation	V <sub>RTH</sub>	V <sub>in</sub> = 14.6V, I <sub>L</sub> = 300mA P <sub>d</sub> = 4 Watts, t = 20 ms, T <sub>A</sub> = 25°C	-16	16	mV
Ripple Rejection (Note 2)	R <sub>N</sub>	f = 120 Hz, V <sub>out</sub> = V <sub>ref</sub> C <sub>Adj</sub> = 10 μF	• 66		dB
Adjustment Pin Current	I <sub>Adj</sub>	V <sub>DIFF</sub> = 3.0V, T <sub>A</sub> = 25°C V <sub>DIFF</sub> = 3.3V V <sub>DIFF</sub> = 40V		100 100 100	μA
Adjustment Pin Current Change	I <sub>Adj</sub>	V <sub>DIFF</sub> = 3.0V, 10mA I <sub>L</sub> .5A, T <sub>A</sub> = 25°C V <sub>DIFF</sub> = 3.3V, 10mA I <sub>L</sub> .5A V <sub>DIFF</sub> = 40V, 10mA I <sub>L</sub> 150mA, T <sub>A</sub> = 25°C V <sub>DIFF</sub> = 40V, 10mA I <sub>L</sub> 100mA 3.0V V <sub>DIFF</sub> 40V, T <sub>A</sub> = 25°C 3.3V V <sub>DIFF</sub> 40V	-5 • -5 • -5 • -5 -5 • -5	5 5 5 5 5 5	μA
Minimum Load Current	I <sub>Lmin</sub>	V <sub>DIFF</sub> = 3.0V, V <sub>OUT</sub> = 1.4V (forced) V <sub>DIFF</sub> = 3.3V, V <sub>OUT</sub> = 1.4V (forced) V <sub>DIFF</sub> = 40V, V <sub>OUT</sub> = 1.4V (forced)		5.0 5.0 5.0	mA
Current Limit (Note 2)	I <sub>CL</sub>	V <sub>DIFF</sub> = 15V V <sub>DIFF</sub> = 40V, T <sub>A</sub> = 25°C	• .5 0.15	1.65 .065	A

**Notes:**

1. Load and Line Regulation are specified at a constant junction temperature. Pulse testing with low duty cycle is used. Changes in output voltage due to heating effects must be taken into account separately.
2. If not tested, shall be guaranteed to the specified limits.
3. The • denotes the specifications which apply over the full operating temperature range.

**STANDARD APPLICATION**

\* C<sub>in</sub> is required if regulator is located an appreciable distance from power supply filter.

\*\* C<sub>o</sub> is not needed for stability, however it does improve transient response.

$$V_{out} = 1.25 V \left( 1 + \frac{R_2}{R_1} \right) + I_{Adj} R_2$$

Since I<sub>Adj</sub> is controlled to less than 100 μA, the error associated with this term is negligible in most applications.

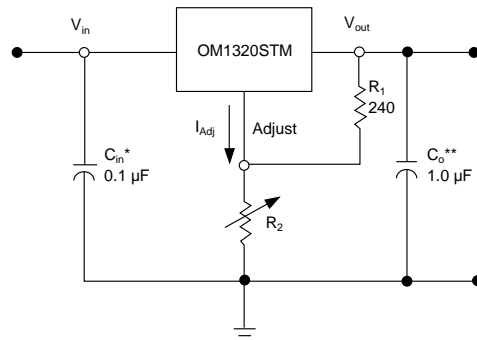

3.5



### MECHANICAL OUTLINE

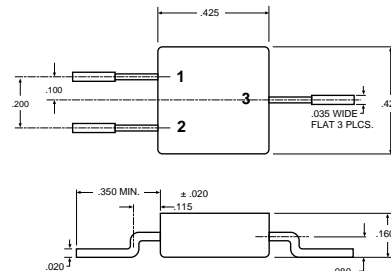
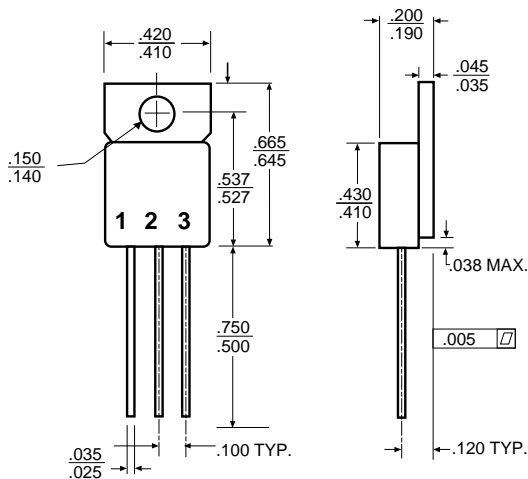

#### OM1320SMM

Front View  
 Pin 1 - Adjust  
 Pin 2 - Input  
 Pin 3 - Output  
 Case - Isolated

**OM1320STM**  
 Isolated  
 Front View  
 Pin 1 - Adjust  
 Pin 2 - Output  
 Pin 3 - Input  
 Tab - Isolated

**OM1320NTM**  
 Non-Isolated  
 Front View  
 Pin 1 - Adjust  
 Pin 2 - Output  
 Pin 3 - Input  
 Tab - Output

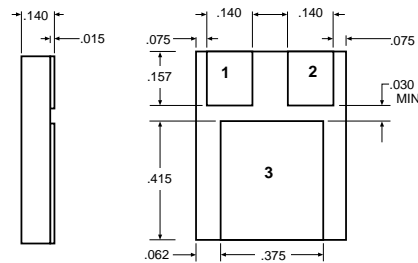

#### OM1320NMM

Pin 1 - Adjust  
 Pin 2 - Input  
 Pin 3 - Output

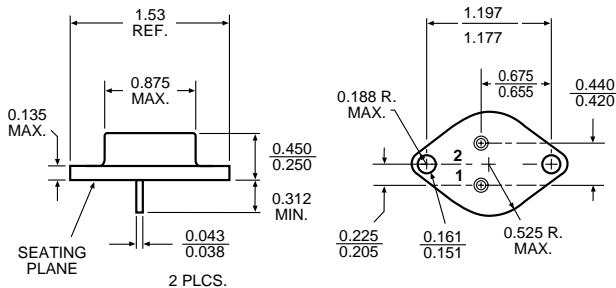

**OM1320NKM**  
 Pin 1 - Adjust  
 Pin 2 - Input  
 Case - Output

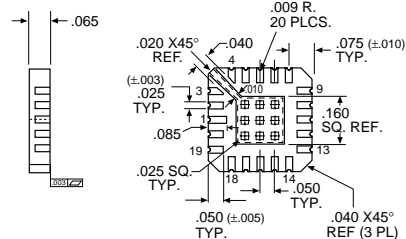

#### OM1320N2M

Pin 1	V <sub>OUT</sub> (Sense)	Pin 11	NC
Pin 2	NC	Pin 12	NC
Pin 3	NC	Pin 13	NC
Pin 4	NC	Pin 14	NC
Pin 5	V <sub>IN</sub>	Pin 15	NC
Pin 6	NC	Pin 16	NC
Pin 7	NC	Pin 17	NC
Pin 8	NC	Pin 18	NC
Pin 9	NC	Pin 19	NC
Pin 10	ADJUST	Pin 20	V <sub>OUT</sub>

For additional information please see the mechanical outline section.

单击下面可查看定价，库存，交付和生命周期等信息

[>>Infineon Technologies\(英飞凌\)](#)