

6ED003L02-F2 and 6ED003L06-F2 family

200 V and 600 V three-phase gate driver with Over Current Protection (OCP), Enable (EN) and Fault

Features

- Infineon thin-film-SOI-technology
- Maximum blocking voltage +600 V
- Output source/sink current +0.165 A/-0.375 A
- Insensitivity of the bridge output to negative transient voltages up to -50 V given by SOI-technology
- Separate control circuits for all six drivers
- Detection of over current and under voltage supply
- Externally programmable delay for fault clear after over current detection
- 'Shut down' of all switches during error conditions
- Signal interlocking of every phase to prevent cross-conduction

Potential applications

- Home appliance, refrigeration compressors, air-conditioning
- Fans, pumps
- Motor drives, general purpose inverters
- Power tools, light electric vehicles

Product validation

Qualified for industrial applications according to the relevant tests of JEDEC47/20/22.

Description

The devices are full bridge drivers to control power devices like MOSFET or IGBTs in 3-phase systems with a maximum blocking voltage of +600 V. Based on the used SOI-technology there is an excellent ruggedness on transient voltages. No parasitic thyristor structures are present in the device. Hence, no parasitic latch-up may occur at all temperatures and voltage conditions.

The six independent drivers are controlled at the low-side using CMOS resp. LSTTL compatible signals, down to 3.3 V logic. The device includes an under-voltage detection unit with hysteresis characteristic and an over-current detection. The over-current level is adjusted by choosing the resistor value and the threshold level at pin ITRIP. Both error conditions (under-voltage and over-current) lead to a definite shut down of all six switches. An error signal is provided at the FAULT open drain output pin. The blocking time after over-current can be adjusted with an RC-network at pin RCIN. The input RCIN owns an internal current source of 2.8 μ A. Therefore, the resistor R_{RCIN} is optional. The typical output current can be given with 165 mA for pull-up and 375 mA for pull down. Because of system safety reasons a 310 ns interlocking time has been realised. The function of input EN can optionally be extended with over-temperature detection, using an external NTC-resistor (see Figure 1).

Product summary

| | |
|------------------------------------|-----------------------|
| V_{OFFSET} (6ED003L06-F2) | = 620 V max. |
| V_{OFFSET} (6ED003L02-F2) | = 200 V max. |
| $I_{\text{O+/-}}$ (typ.) | = +0.165 A / -0.375 A |
| $t_{\text{on}} / t_{\text{off}}$ | = 530ns / 490 ns |
| t_i / t_r (typ. $C_L=1$ nF) | = 60 ns / 26 ns |

Package

DSO-28

TSSOP-28

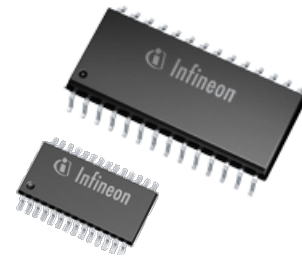

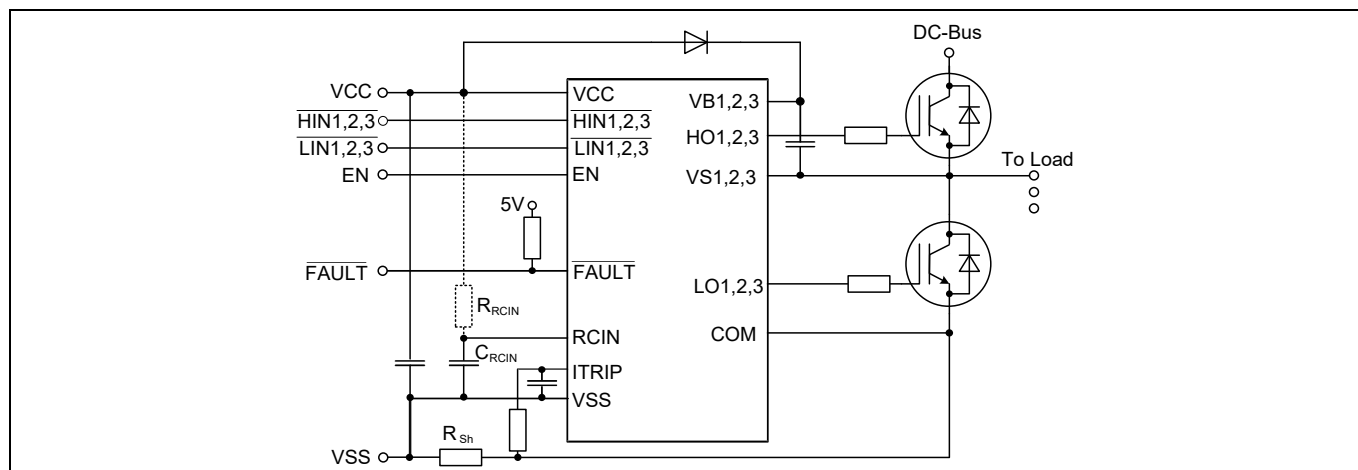

Figure 1 Typical application diagram

Ordering information

Table 1 Members of 6ED003-F2 family – 2nd generation

| Sales Name | High side control input HIN1,2,3 and LIN1,2,3 | Typ. UVLO-Thresholds | Bootstrap diode | Package |
|---|---|----------------------|-----------------|-----------------|
| 6ED003L06-F2 / 6ED003L02-F2 | Negative logic | 11.7 V / 9.8 V | No | DSO28 / TSSOP28 |

Table of contents

| | |
|--|----------|
| Features | 1 |
| Product summary | 1 |
| Package..... | 1 |
| Potential applications | 1 |
| Product validation | 1 |
| Description..... | 1 |
| Ordering information..... | 2 |
| Table of contents..... | 2 |
| 1 Block diagram | 3 |
| 2 Lead definitions..... | 4 |
| 3 Functional description | 5 |
| 3.1 Low Side and High Side Control Pins (Pin 2, 3, 4, 5, 6, 7) | 5 |
| 3.2 EN (Gate Driver Enable, Pin 10)..... | 5 |
| 3.3 /FAULT (Fault Feedback, Pin 8)..... | 6 |
| 3.4 ITRIP and RCIN (Over-Current Detection Function, Pin 9, 11) | 6 |
| 3.5 VCC, VSS and COM (Low Side Supply, Pin 1, 12, 13)..... | 6 |
| 3.6 VB1, 2, 3 and VS1, 2, 3 (High Side Supplies, Pin 18, 20, 22, 24, 26, 28)..... | 6 |
| 3.7 LO1,2,3 and HO1,2,3 (Low and High Side Outputs, Pin 14, 15, 16, 19, 23, 27)..... | 7 |
| 4 Electrical parameters | 8 |
| 4.1 Absolute maximum ratings..... | 8 |
| 4.2 Required operation conditions..... | 9 |

Table of contents

4.3 Operating Range 9

4.4 Static logic function table..... 10

4.5 Static parameters..... 10

4.6 Dynamic parameters..... 12

5 Timing diagrams..... 13

6 Package information 15

6.1 PG-DSO-28 15

6.2 PG-TSSOP-28 16

6.3 PG-TSSOP-28 (according to PCN 2018-165-A)..... 16

7 Qualification information..... 18

8 Related products..... 18

Revision history 18

1 Block diagram

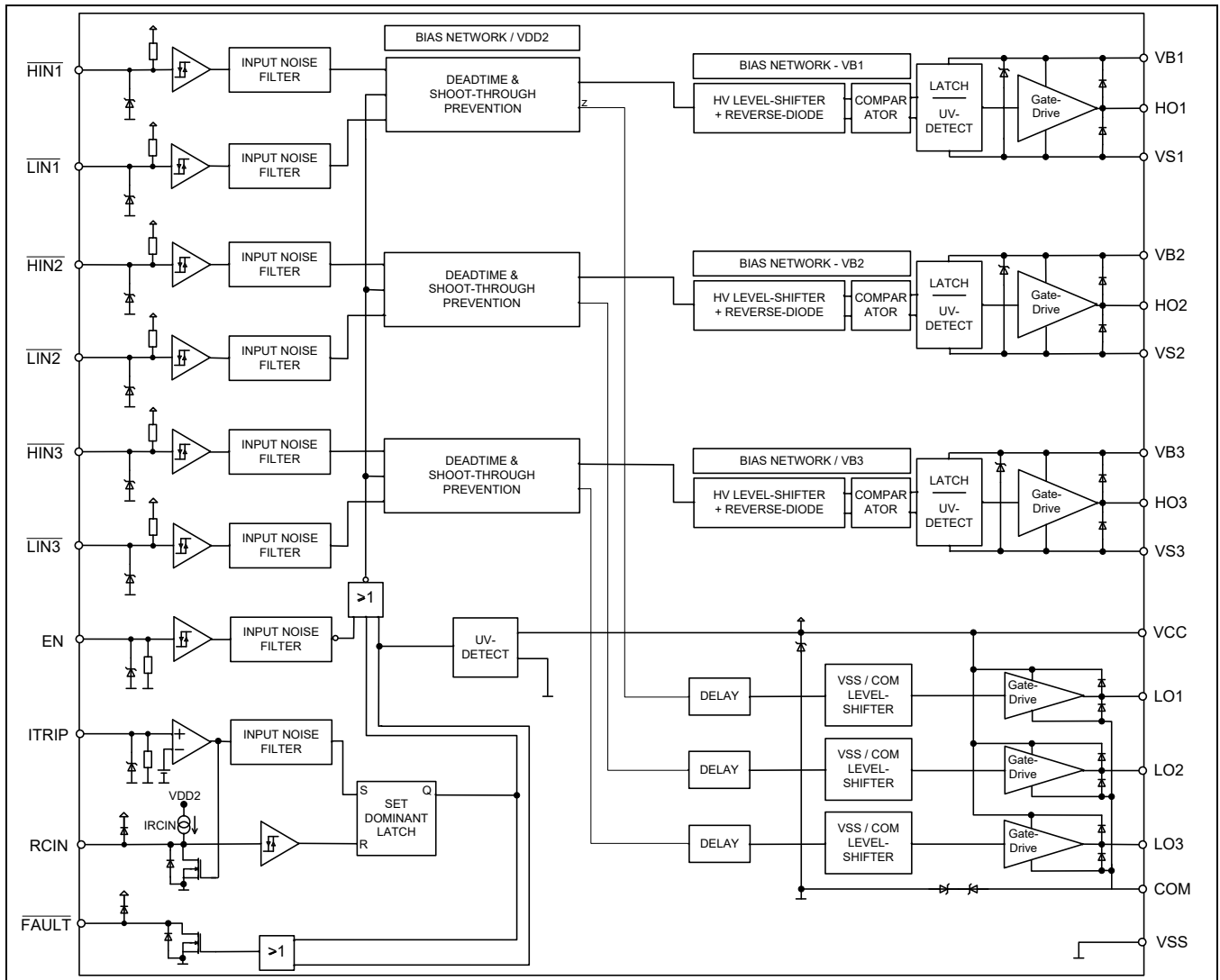

Figure 2 Functional block diagram for 6ED003L06-F2 / 6ED003L02-F2

2 Lead definitions

Table 2 6ED003-F2 family lead definitions

| Pin no. | Name | Function |
|----------|-----------|---|
| 1 | VCC | Low side power supply |
| 2,3,4 | /HIN1,2,3 | High side logic input |
| 5,6,7 | /LIN1,2,3 | Low side logic input |
| 8 | /FAULT | Indicates over-current and under-voltage (negative logic, open-drain output) |
| 9 | ITRIP | Analog input for over-current shut down, activates FAULT and RCIN to VSS |
| 10 | EN | Enable I/O functionality (positive logic) |
| 11 | RCIN | External RC-network to define FAULT clear delay after FAULT-Signal (T_{FLTCLR}) |
| 12 | VSS | Logic ground |
| 13 | COM | Low side gate driver reference |
| 28,24,20 | VB1,2,3 | High side positive power supply |
| 27,23,19 | HO1,2,3 | High side gate driver output |
| 26,22,18 | VS1,2,3 | High side negative power supply |
| 16,15,14 | LO1,2,3 | Low side gate driver output |
| 21,25 | nc | Not connected |

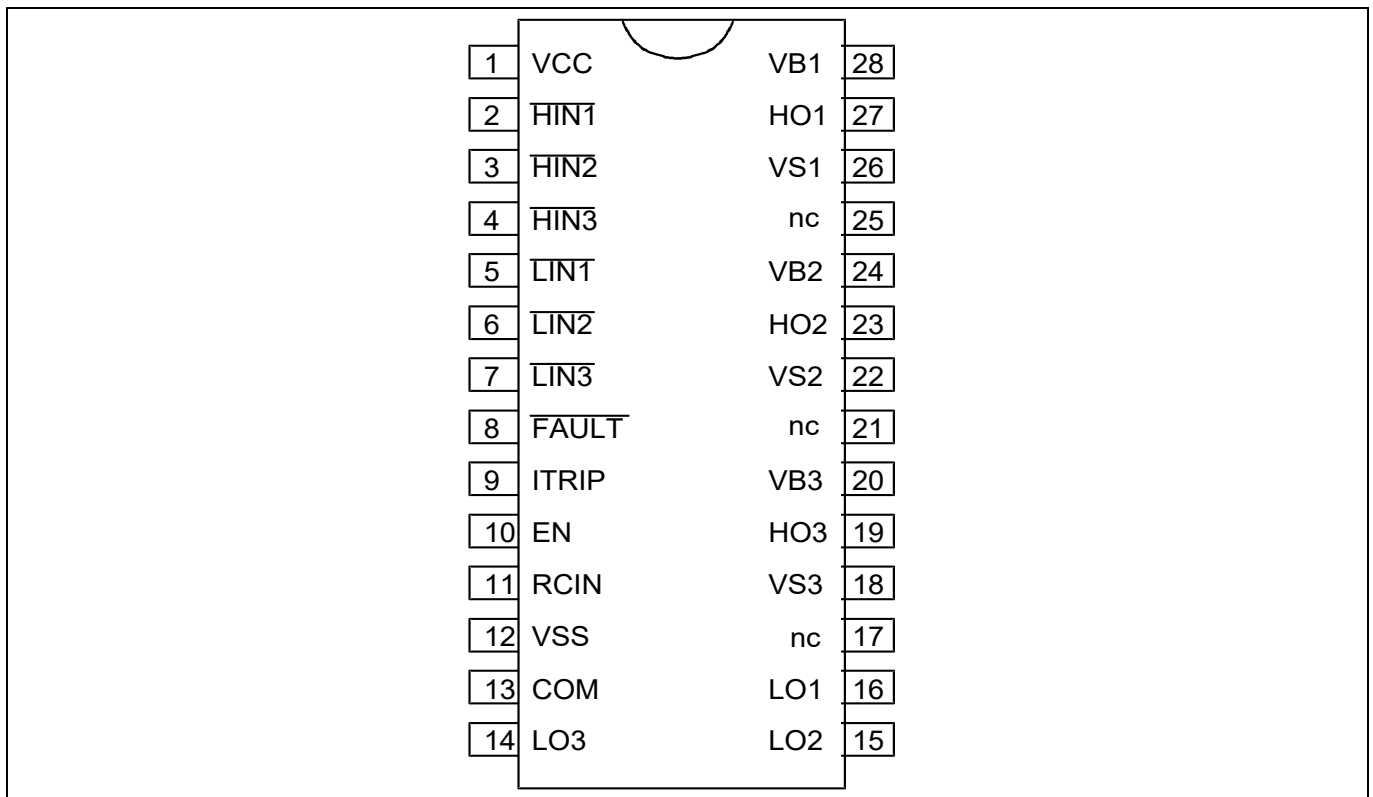

Figure 3 Pin Configuration of 6ED003L06-F2 and 6ED003L02-F2

3 Functional description

3.1 Low Side and High Side Control Pins (Pin 2, 3, 4, 5, 6, 7)

The Schmitt trigger input threshold of them are such to guarantee LSTTL and CMOS compatibility down to 3.3 V controller outputs. Input Schmitt trigger and noise filter provide beneficial noise rejection to short input pulses according to Figure 4 and Figure 5.

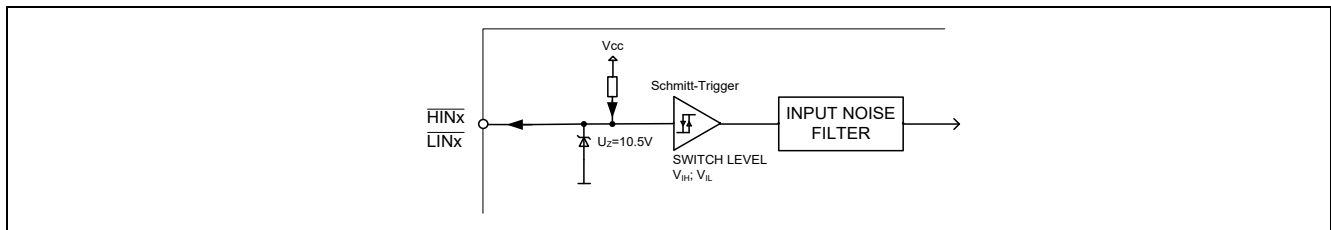

Figure 4 Input pin structure

An internal pull-up of about 75 kΩ (negative logic) pre-biases the input during supply start-up and a ESD zener clamp is provided for pin protection purposes. The zener diodes are therefore designed for single pulse stress only and not for continuous voltage stress over 10 V.

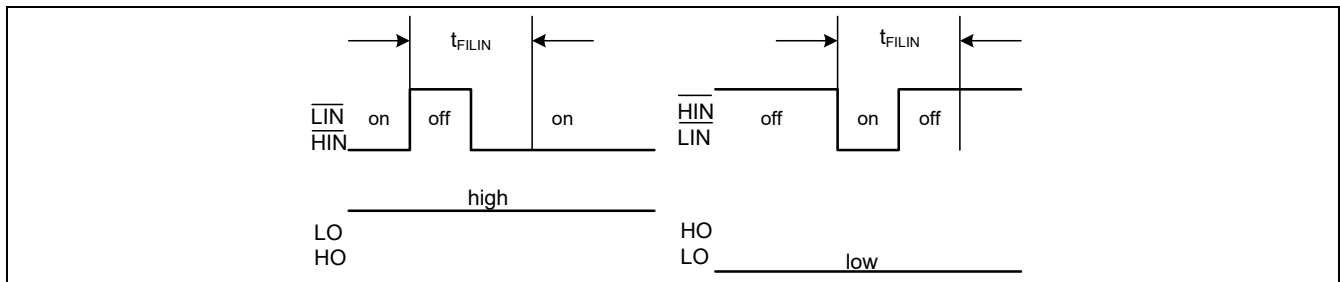

Figure 5 Input filter timing diagram

It is anyway recommended for proper work of the driver not to provide input pulse-width lower than 1 μs.

The 6ED-F2 driver IC provide additionally a shoot through prevention capability which avoids the simultaneous on-state of two channels of the same leg (i.e. HO1 and LO1, HO2 and LO2, HO3 and LO3). When two inputs of a same leg are activated, only one leg output is activated, so that the leg is kept steadily in a safe state.

A minimum dead time insertion of typ. 310 ns is also provided, in order to reduce cross-conduction of the external power switches.

3.2 EN (Gate Driver Enable, Pin 10)

The signal applied to pin EN controls directly the output stages. All outputs are set to LOW, if EN is at LOW logic level. The internal structure of the pin is given in Figure 6. The switching levels of the Schmitt-Trigger are here $V_{EN,TH+} = 2.1 V$ and $V_{EN,TH-} = 1.3 V$. The typical propagation delay time is $t_{EN} = 780 ns$. There is an internal pull down resistor (75 kΩ), which keeps the gate outputs off in case of broken PCB connection.

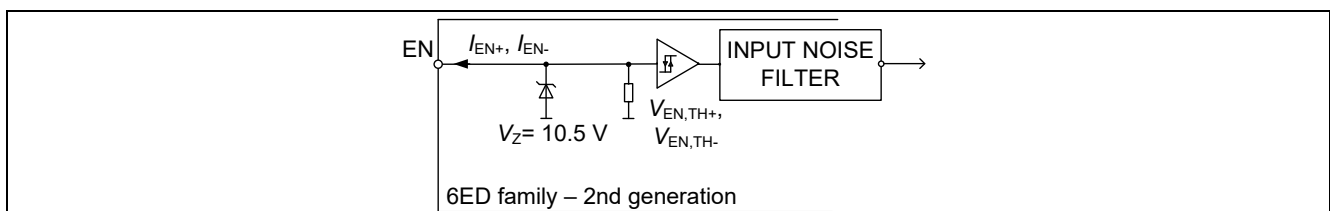

Figure 6 EN pin structures

3.3 /FAULT (Fault Feedback, Pin 8)

/Fault pin is an active low open-drain output indicating the status of the gate driver (see **Error! Reference source not found.**). The pin is active (i.e. forces LOW voltage level) when one of the following conditions occur:

- Under-voltage condition of VCC supply: In this case the fault condition is released as soon as the supply voltage condition returns in the normal operation range (please refer to VCC pin description for more details).
- Over-current detection (ITRIP): The fault condition is latched until current trip condition is finished and RCIN input is released (please refer to ITRIP pin).

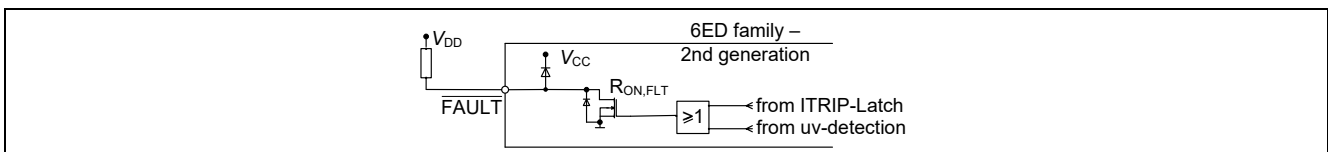

Figure 7 /FAULT pin structures

3.4 ITRIP and RCIN (Over-Current Detection Function, Pin 9, 11)

The 6ED family – 2nd generation provides an over-current detection function by connecting the ITRIP input with the motor current feedback. The ITRIP comparator threshold (typ 0.44 V) is referenced to VSS ground. An input noise filter (typ. $t_{TRIPMIN} = 230$ ns) prevents the driver to detect false over-current events.

Over-current detection generates a hard shut down of all outputs of the gate driver and provides a latched fault feedback at /FAULT pin. RCIN input/output pin is used to determine the reset time of the fault condition. As soon as ITRIP threshold is exceeded the external capacitor connected to RCIN is fully discharged. The capacitor is then recharged by the RCIN current generator when the over-current condition is finished. As soon as RCIN voltage exceeds the rising threshold of typ $V_{RCIN,TH} = 5.2$ V, the fault condition releases and the driver returns operational following the control input pins according to section 3.1.

3.5 VCC, VSS and COM (Low Side Supply, Pin 1, 12, 13)

VCC is the low side supply and it provides power both to input logic and to low side output power stage. Input logic is referenced to VSS ground as well as the under-voltage detection circuit. Output power stage is referenced to COM ground. COM ground is floating respect to VSS ground with a maximum range of operation of +/-5.7 V. A back-to-back zener structure protects grounds from noise spikes.

The under-voltage circuit enables the device to operate at power on when a typical supply voltage higher than V_{CCUV+} is present.

The IC shuts down all the gate drivers power outputs, when the VCC supply voltage is below $V_{CCUV-} = 9.8$ V. This prevents the external power switches from critically low gate voltage levels during on-state and therefore from excessive power dissipation. Please consult the individual output characteristic of the driven transistor.

3.6 VB1, 2, 3 and VS1, 2, 3 (High Side Supplies, Pin 18, 20, 22, 24, 26, 28)

VB to VS is the high side supply voltage. The high side circuit can float with respect to VSS following the external high side power device emitter/source voltage. Due to the low power consumption, the floating driver stage can be supplied by bootstrap topology connected to VCC. The device operating area as a function of the supply voltage is given in Figure 12.

3.7 LO1,2,3 and HO1,2,3 (Low and High Side Outputs, Pin 14, 15, 16, 19, 23, 27)

Low side and high side power outputs are specifically designed for pulse operation such as gate drive of IGBT and MOSFET devices. Low side outputs (i.e. LO1,2,3) are state triggered by the respective inputs, while high side outputs (i.e. HO1,2,3) are edge triggered by the respective inputs. In particular, after an under voltage condition of the VBS supply, a new turn-on signal (edge) is necessary to activate the respective high side output, while after a under voltage condition of the VCC supply, the low side outputs switch to the state of their respective inputs.

4 Electrical parameters

4.1 Absolute maximum ratings

All voltages are absolute voltages referenced to V_{SS} -potential unless otherwise specified. All parameters are valid for $T_a=25\text{ }^\circ\text{C}$.

Table 3 Absolute maximum ratings

| Parameter | Symbol | Min. | Max. | Unit |
|---|---------------|-----------------------|------------------|------------------|
| High side offset voltage ¹ | V_S | $V_{CC} - V_{BS} - 6$ | 600 180 | V |
| High side offset voltage ($t_p < 500\text{ ns}$) ¹ | | | | |
| High side offset voltage ¹ | V_B | $V_{CC} - 6$ | 620 200 | |
| High side offset voltage ($t_p < 500\text{ ns}$) ¹ | | | | |
| High side floating supply voltage (V_B vs. V_S) (internally clamped) | V_{BS} | -1 | 20 | |
| High side output voltage (V_{HO} vs. V_S) | V_{HO} | -0.5 | $V_B + 0.5$ | |
| Low side supply voltage (internally clamped) | V_{CC} | -1 | 20 | |
| Low side supply voltage (V_{CC} vs. V_{COM}) | V_{CCOM} | -0.5 | 25 | |
| Gate driver ground | V_{COM} | -5.7 | 5.7 | |
| Low side output voltage (V_{LO} vs. V_{COM}) | V_{LO} | -0.5 | $V_{CCOM} + 0.5$ | |
| Input voltage LIN,HIN,EN,ITRIP | V_{IN} | -1 | 10 | |
| FAULT output voltage | V_{FLT} | -0.5 | $V_{CC} + 0.5$ | |
| RCIN output voltage | V_{RCIN} | -0.5 | $V_{CC} + 0.5$ | |
| Power dissipation (to package) ² | P_D | - | 1.3 | W |
| | | | 0.6 | |
| Thermal resistance (junction to ambient, see section Error! Reference source not found.) | $R_{th(j-a)}$ | - | 75 | K/W |
| | | | 165 | |
| Junction temperature | T_J | - | 125 | $^\circ\text{C}$ |
| Storage temperature | T_S | -40 | 150 | |
| offset voltage slew rate ³ | dV_S/dt | | 50 | V/ns |

Note: The minimum value for ESD immunity in PG-DSO-28 is 2.0 kV (Human Body Model). ESD immunity inside pins connected to the low side (V_{CC} , $HINx$, $LINx$, $FAULT$, EN , $RCIN$, $ITRIP$, V_{SS} , COM , LOx) and pins connected inside each high side itself (V_{Bx} , HOx , VSx) is guaranteed up to 2.0 kV (Human Body Model). See [section 7](#).

The minimum value for ESD immunity in PG-TSSOP-28 is 1.0 kV (Human Body Model). ESD immunity inside pins connected to the low side (V_{CC} , $HINx$, $LINx$, $FAULT$, EN , $RCIN$, $ITRIP$, V_{SS} , COM , LOx) and pins connected inside each high side itself (V_{Bx} , HOx , VSx) is guaranteed up to 1.5 kV (Human Body Model). See [section 7](#).

¹ Insensitivity of bridge output to negative transient voltage up to -50 V is not subject to production test - verified by design / characterization.

² Consistent power dissipation of all outputs. All parameters inside operating range.

³ Not subject of production test, verified by characterisation

4.2 Required operation conditions

All voltages are absolute voltages referenced to V_{SS} -potential unless otherwise specified. All parameters are valid for $T_a=25\text{ °C}$.

Table 4 Required Operation Conditions

| Parameter | | Symbol | Min. | Max. | Unit |
|--|------------------|------------|------|------------|------|
| High side offset voltage ¹ | DSO28 TSSOP28 | V_B | 7 | 620 200 | V |
| Low side supply voltage (V_{CC} vs. V_{COM}) | DSO28 TSSOP28 | V_{CCOM} | 10 | 25 | |

4.3 Operating Range

All voltages are absolute voltages referenced to V_{SS} -potential unless otherwise specified. All parameters are valid for $T_a=25\text{ °C}$.

Table 5 Operating range

| Parameter | Symbol | Min. | Max. | Unit |
|---|------------|-----------------------|----------|--------------------|
| High side floating supply offset voltage | V_S | $V_{CC} - V_{BS} - 1$ | 500 | V |
| High side floating supply offset voltage (V_B vs. V_{CC} , statically) | V_{BCC} | -1.0 | 500 | |
| High side floating supply voltage (V_B vs. V_S , Note 1) | V_{BS} | 13 | 17.5 | |
| High side output voltage (V_{HO} vs. V_S) | V_{HO} | 0 | V_{BS} | |
| Low side output voltage (V_{LO} vs. V_{COM}) | V_{LO} | 0 | V_{CC} | |
| Low side supply voltage | V_{CC} | 13 | 17.5 | |
| Low side ground voltage | V_{COM} | -2.5 | 2.5 | |
| Logic input voltages /LIN, /HIN, EN, ITRIP ² | V_{IN} | 0 | 5 | |
| FAULT output voltage | V_{FLT} | 0 | V_{CC} | |
| RCIN input voltage | V_{RCIN} | 0 | V_{CC} | |
| Pulse width for ON or OFF ³ | t_{IN} | 1 | - | μs |
| Ambient temperature | T_a | -40 | 105 | $^{\circ}\text{C}$ |

¹ Logic operational for V_B (V_B vs. V_S) > 7.0 V

² All input pins (/HINx, /LINx) and EN, ITRIP pin are internally clamped (see abs. maximum ratings)

³ In case of input pulse width at /LINx and /HINx below 1 μs the input pulse may not be transmitted properly

4.4 Static logic function table

| VCC | VBS | RCIN | ITRIP | ENABLE | FAULT | LO1,2,3 | HO1,2,3 |
|---------------|---------------|----------------------|---------------|--------|----------|-----------|-----------|
| $< V_{CCUV-}$ | X | X | X | X | 0 | 0 | 0 |
| 15V | $< V_{BSUV-}$ | X | 0 | 3.3 V | High imp | /LIN1,2,3 | 0 |
| 15V | 15V | $< 3.2 V \downarrow$ | 0 | 3.3 V | 0 | 0 | 0 |
| 15V | 15V | X | $> V_{T,TH+}$ | 3.3 V | 0 | 0 | 0 |
| 15V | 15V | $> V_{RCIN,TH}$ | 0 | 3.3 V | High imp | /LIN1,2,3 | /HIN1,2,3 |
| 15V | 15V | $> V_{RCIN,TH}$ | 0 | 0 | High imp | 0 | 0 |

4.5 Static parameters

$V_{CC} = V_{BS} = 15 V$ unless otherwise specified. All parameters are valid for $T_a = 25^\circ C$.

Table 6 Static parameters

| Parameter | Symbol | Values | | | Unit | Test condition |
|--|----------------------------|---------|------|------------------|------------------|-----------------------------------|
| | | Min. | Typ. | Max. | | |
| High level input voltage | V_{IH} | 1.7 | 2.1 | 2.4 | V | |
| Low level input voltage | V_{IL} | 0.7 | 0.9 | 1.1 | | |
| EN positive going threshold | $V_{EN,TH+}$ | 1.9 | 2.1 | 2.3 | | |
| EN negative going threshold | $V_{EN,TH-}$ | 1.1 | 1.3 | 1.5 | | |
| ITRIP positive going threshold | $V_{IT,TH+}$ | 380 | 445 | 510 | mV | |
| ITRIP input hysteresis | $V_{IT,HYS}$ | 45 | 70 | | | |
| RCIN positive going threshold | $V_{RCIN,TH}$ | - | 5.2 | 6.4 | V | |
| RCIN input hysteresis | $V_{RCIN,HYS}$ | - | 2.0 | - | | |
| Input clamp voltage (/HIN, /LIN, EN, ITRIP) | $V_{IN,CLMAP}$ | 9 | 10.3 | 12 | | $I_N = 4mA$ |
| Input clamp voltage at high impedance (/HIN, /LIN) | $V_{IN,FLOAT}$ | - | 5.3 | 5.8 | | controller output pin floating |
| High level output voltage | V_{OH} | LO1,2,3 | - | $V_{CC} - 0.7$ | $V_{CC} - 1.4$ | $I_O = 20mA$ |
| | | HO1,2,3 | - | $V_B - 0.7$ | $V_B - 1.4$ | |
| Low level output voltage | V_{OL} | LO1,2,3 | - | $V_{COM+} - 0.2$ | $V_{COM+} - 0.6$ | $I_O = -20mA$ |
| | | HO1,2,3 | - | $V_S + 0.2$ | $V_S + 0.6$ | |
| V_{CC} and V_{BS} supply undervoltage positive going threshold | V_{CCUV+} V_{BSUV+} | 11 | 11.7 | 12.5 | V | |
| V_{CC} and V_{BS} supply undervoltage negative going threshold | V_{CCUV-} V_{BSUV-} | 9.5 | 9.8 | 10.8 | | |
| V_{CC} and V_{BS} supply undervoltage lockout hysteresis | V_{CCUVH} V_{BSUVH} | 1.2 | 1.9 | - | | |
| High side leakage current betw. VS and VSS | I_{LVS+} | - | 1 | 12.5 | μA | $V_S = 600V$ |

Table 6 Static parameters

| Parameter | Symbol | Values | | | Unit | Test condition |
|---|---------------|--------|------|------|---------------|--|
| | | Min. | Typ. | Max. | | |
| High side leakage current betw. VS and VSS | I_{LVS+}^1 | - | 10 | - | μA | $T_J = 125^\circ\text{C}$, $V_S = 600\text{V}$ |
| High side leakage current between VSx and VSy (x=1,2,3 and y=1,2,3) | I_{LVS-}^1 | - | 10 | - | | $T_J = 125^\circ\text{C}$ $V_{Sx} - V_{Sy} = 600\text{V}$ |
| Quiescent current V_{BS} supply (VB only) | I_{QBS1} | - | 210 | 400 | μA | HO=low |
| Quiescent current V_{BS} supply (VB only) | I_{QBS2} | - | 210 | 400 | | HO=high |
| Quiescent current V_{CC} supply (VCC only) | I_{QCC1} | - | 1.1 | 1.8 | mA | $V_{LIN}=\text{float.}$ |
| Quiescent current V_{CC} supply (VCC only) | I_{QCC2} | - | 1.3 | 2 | | $V_{LIN}=0$, $V_{HIN}=3.3\text{V}$ |
| Input bias current | I_{LIN+} | - | 70 | 100 | μA | $V_{LIN}=3.3\text{V}$ |
| Input bias current | I_{LIN-} | - | 110 | 200 | μA | $V_{LIN}=0$ |
| Input bias current | I_{HIN+} | - | 70 | 100 | | $V_{HIN}=3.3\text{V}$ |
| Input bias current | I_{HIN-} | - | 110 | 200 | | $V_{HIN}=0$ |
| Input bias current (ITRIP=high) | I_{ITRIP+} | | 45 | 120 | | $V_{ITRIP}=3.3\text{V}$ |
| Input bias current (EN=high) | I_{EN+} | - | 45 | 120 | | $V_{ENABLE}=3.3\text{V}$ |
| Input bias current RCIN (internal current source) | I_{RCIN} | | 2.8 | | | $V_{RCIN} = 2\text{V}$ |
| Mean output current for load capacity charging in range from 3 V (20%) to 6 V (40%) | I_{O+} | 120 | 165 | - | mA | $C_L=10\text{ nF}$ |
| Peak output current turn on (single pulse) | I_{Opk+}^1 | | 240 | | | $R_L = 0$, $t_p < 10\ \mu\text{s}$ |
| Mean output current for load capacity discharging in range from 12 V (80%) to 9 V (60%) | I_{O-} | 250 | 375 | - | | $C_L=10\text{ nF}$ |
| Peak output current turn off (single pulse) | I_{Opk-}^1 | | 420 | | | $R_L = 0$, $t_p < 10\ \mu\text{s}$ |
| RCIN low on resistance of the pull down transistor | $R_{on,RCIN}$ | - | 40 | 100 | | $V_{RCIN}=0.5\text{V}$ |
| FAULT low on resistance of the pull down transistor | $R_{on,FLT}$ | - | 45 | 100 | | $V_{FAULT}=0.5\text{V}$ |

¹ Not subject of production test, verified by characterisation

4.6 Dynamic parameters

$V_{CC} = V_{BS} = 15\text{ V}$, $V_S = V_{SS} = V_{COM}$ unless otherwise specified. All parameters are valid for $T_a = 25\text{ }^\circ\text{C}$.

Table 7 Dynamic parameters

| Parameter | Symbol | Values | | | Unit | Test condition |
|---|----------------|--------|------|------|------|---|
| | | Min. | Typ. | Max. | | |
| Turn-on propagation delay | t_{on} | 400 | 530 | 800 | ns | $V_{LIN/HIN} = 0\text{ or }3.3\text{ V}$ |
| Turn-off propagation delay | t_{off} | 360 | 490 | 760 | | |
| Turn-on rise time | t_r | - | 60 | 100 | | $V_{LIN/HIN} = 0\text{ or }3.3\text{ V}$ |
| Turn-off fall time | t_f | - | 26 | 45 | | $C_L = 1\text{ nF}$ |
| Shutdown propagation delay ENABLE | t_{EN} | - | 780 | 1100 | | $V_{EN} = 0$ |
| Shutdown propagation delay ITRIP | t_{ITRIP} | 400 | 670 | 1000 | | $V_{ITRIP} = 1\text{ V}$ |
| Input filter time ITRIP | $t_{ITRIPMIN}$ | 155 | 230 | 380 | | |
| Propagation delay ITRIP to FAULT | t_{FLT} | - | 420 | 700 | | |
| Input filter time at LIN/HIN for turn on and off | t_{FILIN} | 120 | 300 | - | | $V_{LIN/HIN} = 0\text{ \& }3.3\text{ V}$ |
| Input filter time EN | t_{FILEN} | 300 | 600 | - | | |
| Fault clear time at RCIN after ITRIP-fault, ($C_{RCin} = 1\text{ nF}$) | t_{FLTCLR} | 1.0 | 1.9 | 3.0 | ms | $V_{LIN/HIN} = 0\text{ \& }3.3\text{ V}$ $V_{ITRIP} = 0$ |
| Dead time | DT | 150 | 310 | - | | $V_{LIN/HIN} = 0\text{ \& }3.3\text{ V}$ |
| Matching delay ON, max(t_{on})-min(t_{on}), t_{on} are applicable to all 6 driver outputs | MT_{ON} | - | 20 | 100 | ns | external dead time > 500 ns |
| Matching delay OFF, max(t_{off})-min(t_{off}), t_{off} are applicable to all 6 driver outputs | MT_{OFF} | - | 40 | 100 | | external dead time > 500 ns |
| Output pulse width matching. $PW_{in} - PW_{out}$ | PM | | 40 | 100 | | $PW_{in} > 1\text{ }\mu\text{s}$ |

5 Timing diagrams

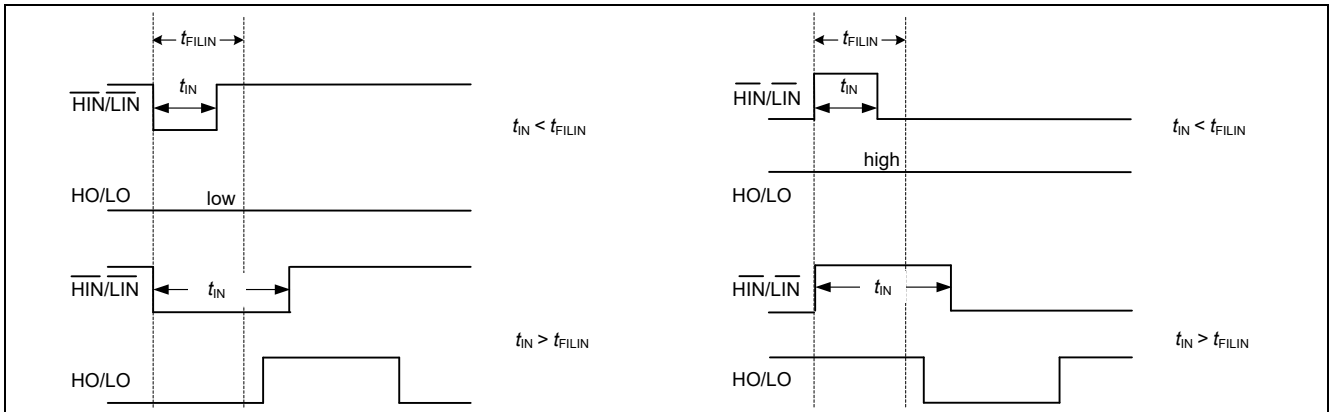

Figure 8 Timing of short pulse suppression

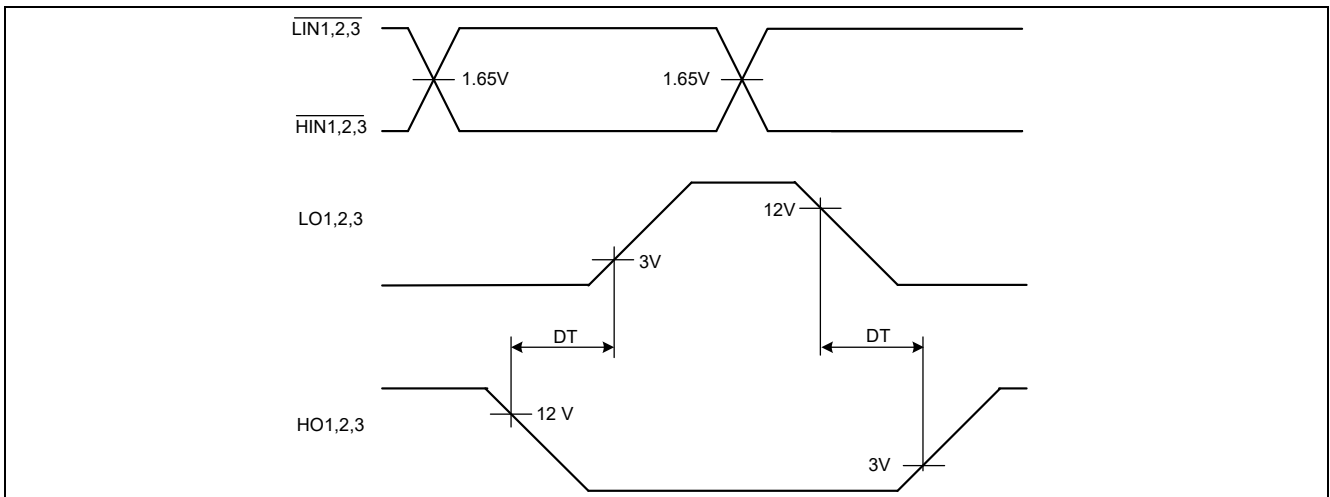

Figure 9 Timing of internal deadtime

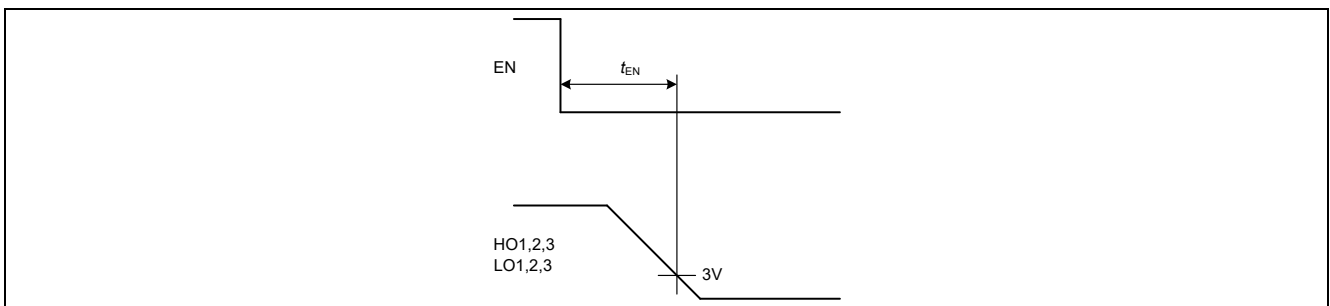

Figure 10 Enable delay time definition

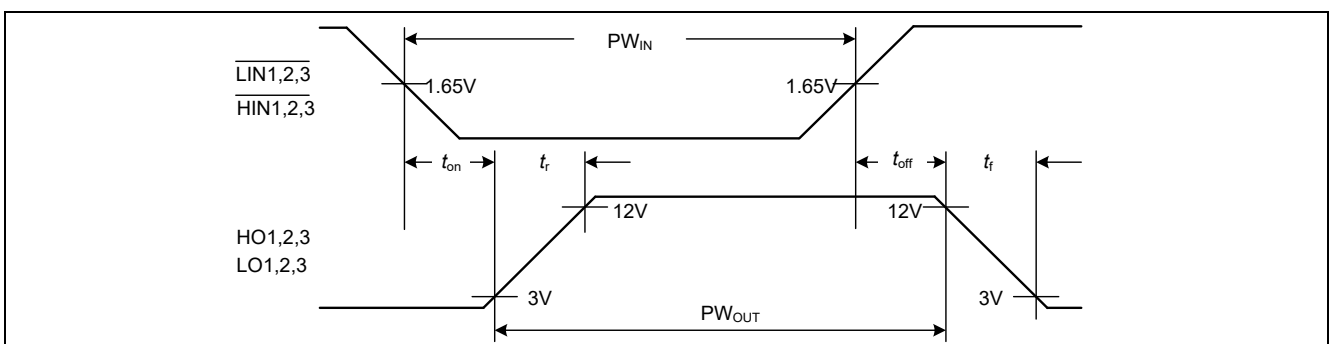

Figure 11 Input to output propagation delay times and switching times definition

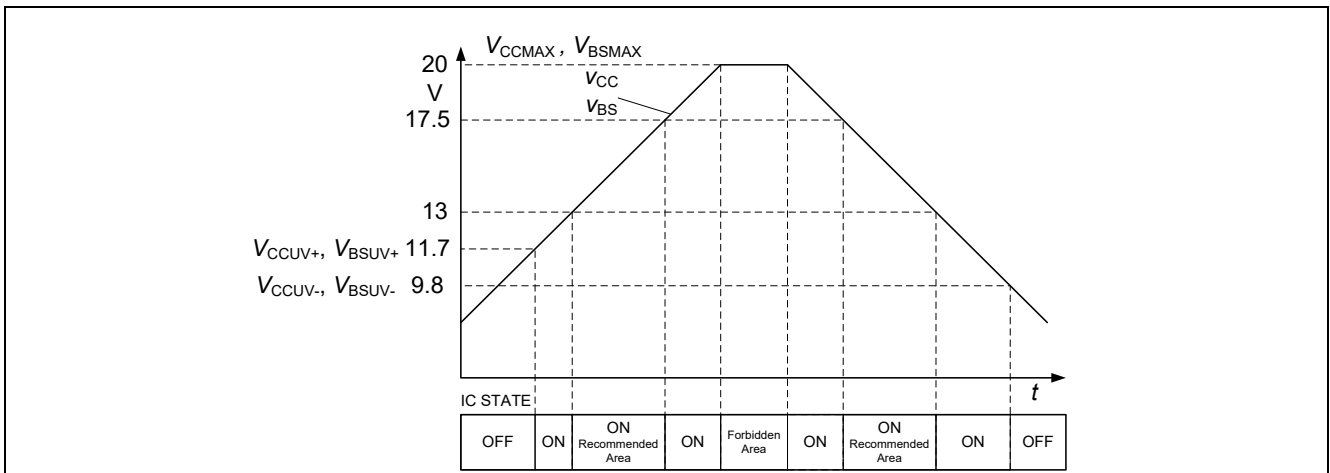

Figure 12 Operating areas

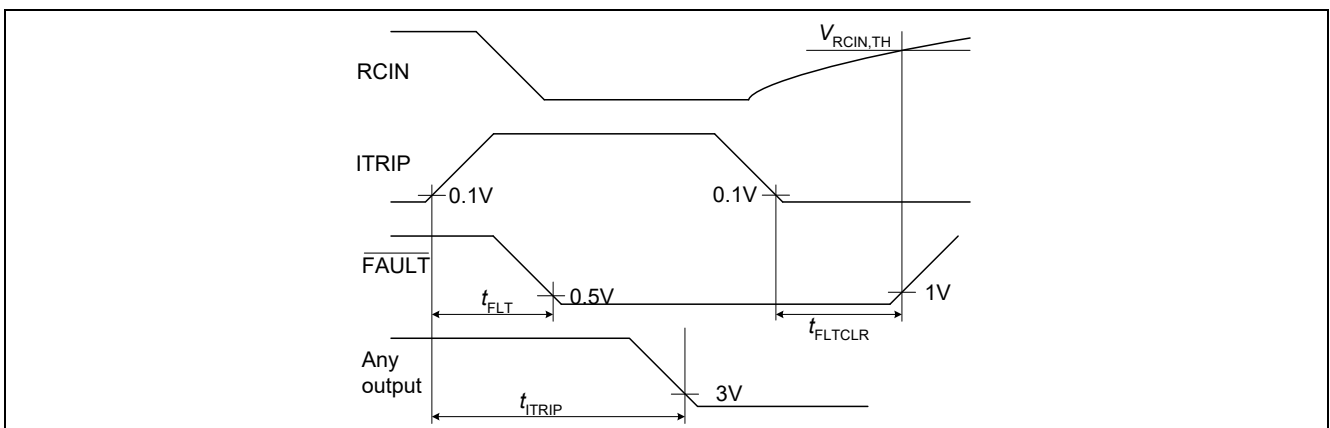

Figure 13 ITRIP-Timing

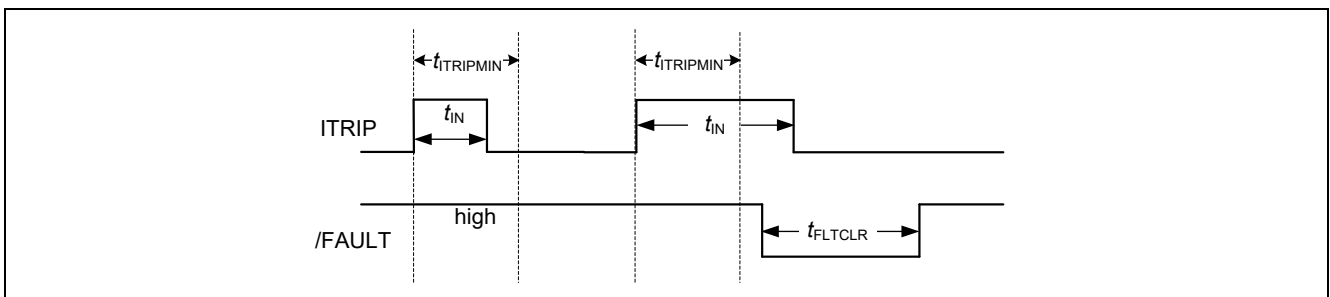

Figure 14 ITRIP input filter time

6 Package information

6.1 PG-DSO-28

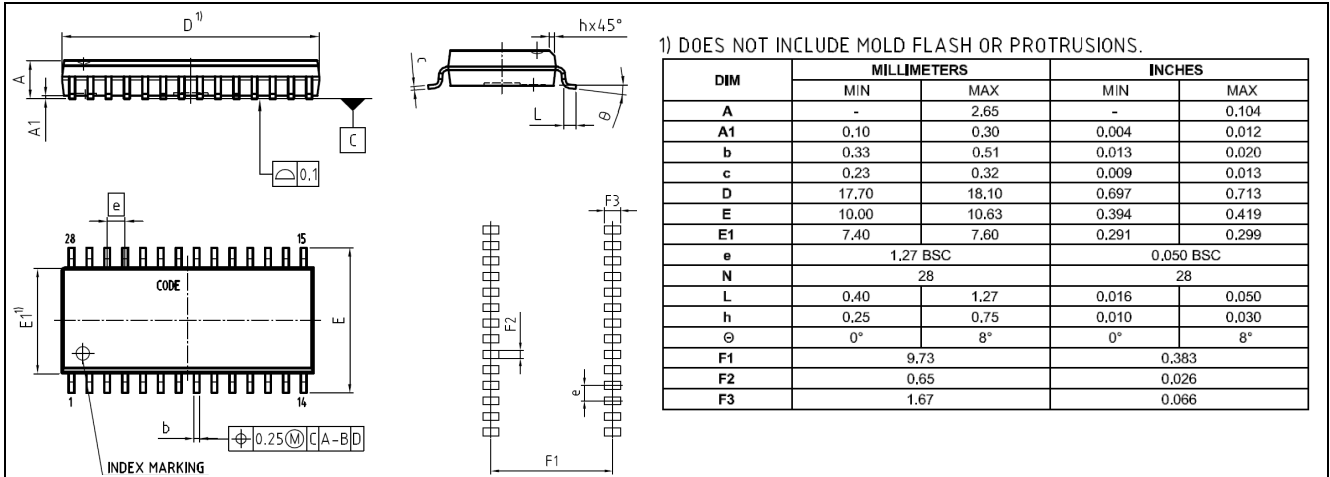

Figure 15 Package drawing

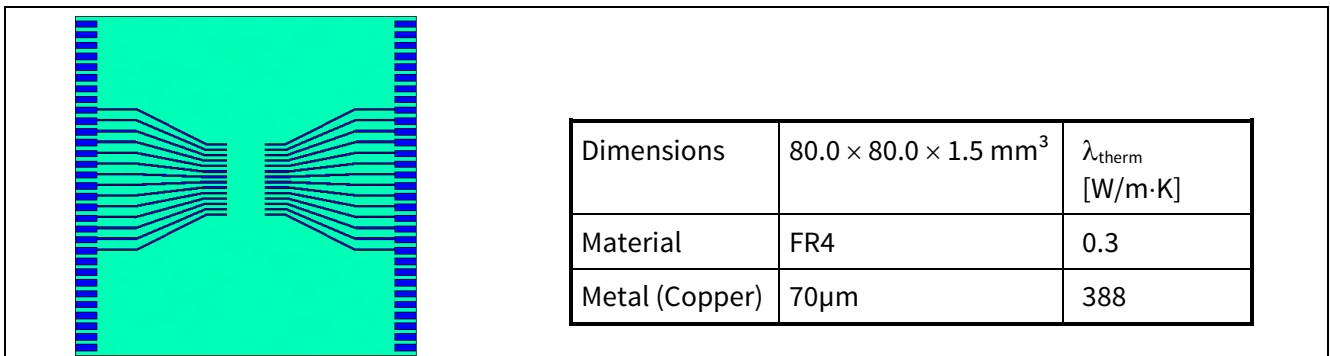

Figure 16 PCB reference layout

6.2 PG-TSSOP-28

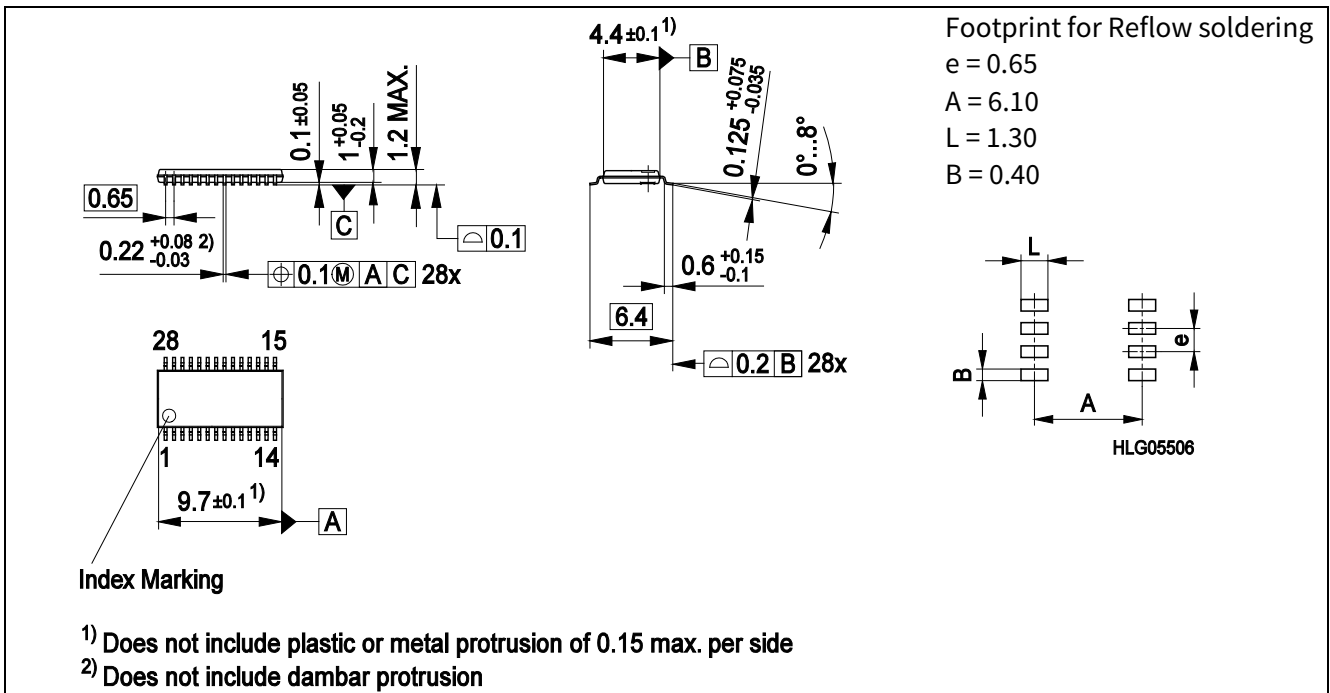

Figure 17 Package drawing

6.3 PG-TSSOP-28 (according to PCN 2018-165-A)

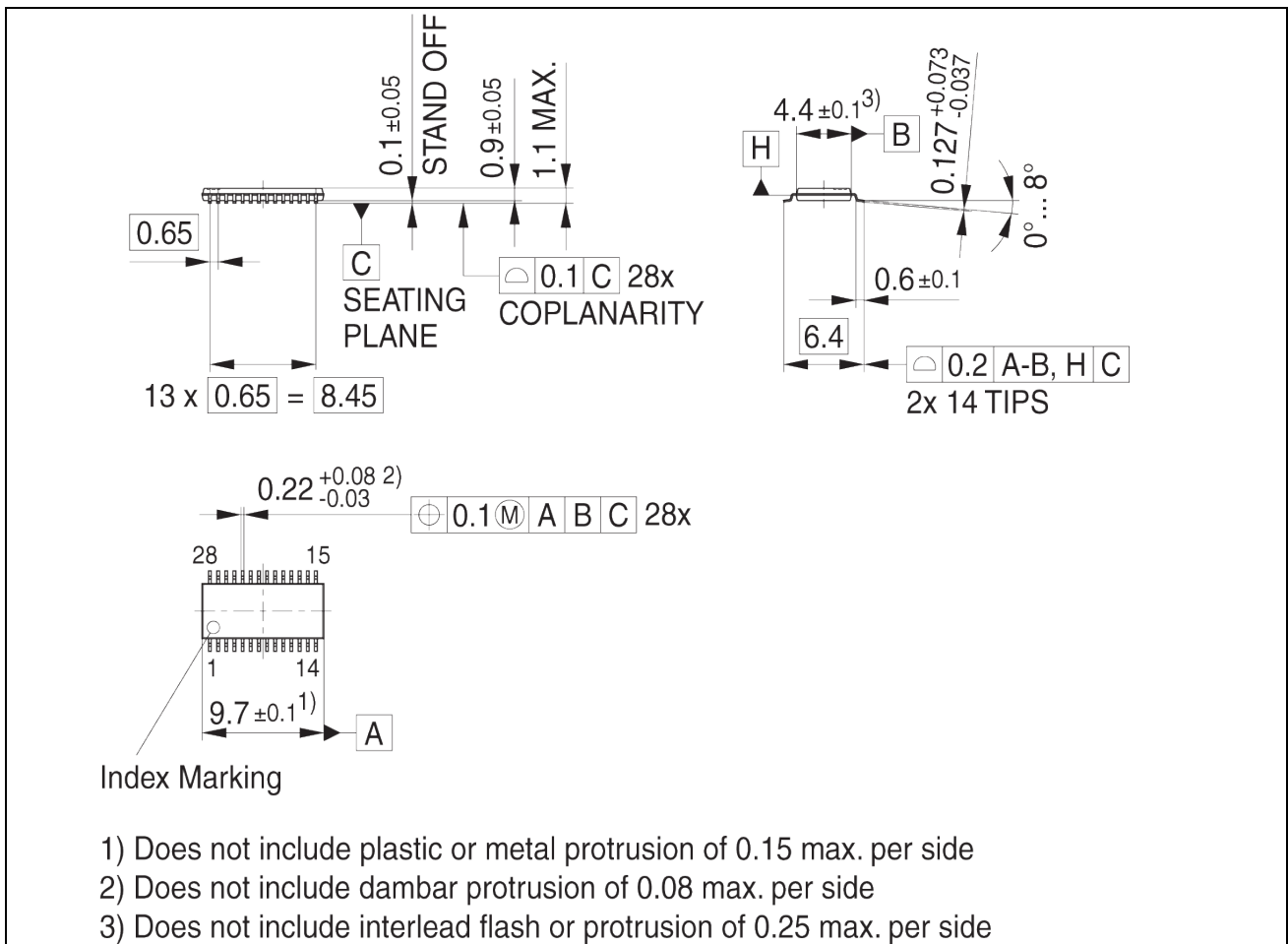

Figure 18 Package drawing

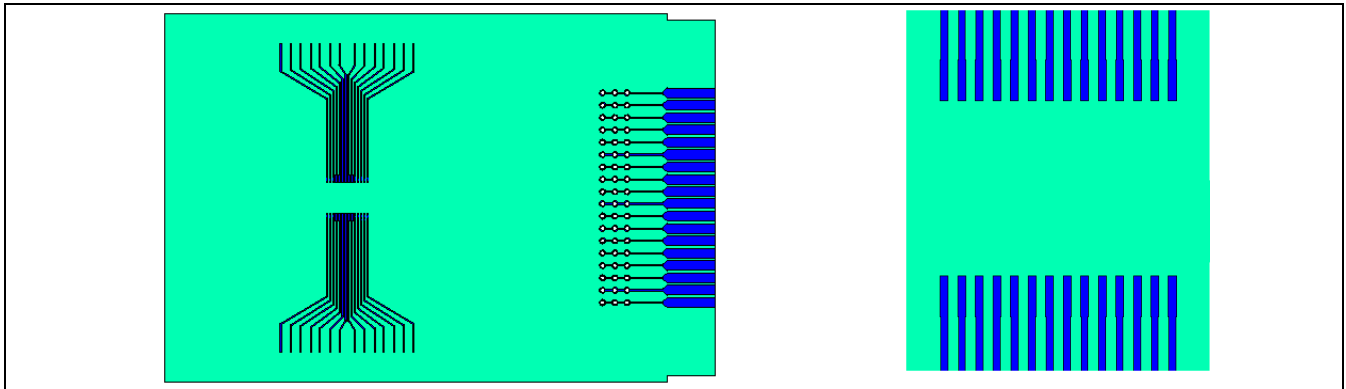

Figure 19 PCB reference layout (according to JEDEC 1s0P)
 left: Reference layout
 right: detail of footprint

Table 8 Data of reference layout

| Dimensions | Material | Metal (Copper) |
|------------------------------------|---|--|
| 76.2 × 114.3 × 1.5 mm ³ | FR4 ($\lambda_{\text{therm}} = 0.3 \text{ W/mK}$) | 70μm ($\lambda_{\text{therm}} = 388 \text{ W/mK}$) |

7 Qualification information¹

Table 9 Qualification information

| Qualification level | | Industrial ² | |
|----------------------------|----------------------|--|--|
| | | Note: This family of ICs has passed JEDEC's Industrial qualification. Consumer qualification level is granted by extension of the higher Industrial level. | |
| Moisture sensitivity level | | TSSOP-28/DSO-28 | MSL3 ³ , 260°C (per IPC/JEDEC J-STD-020) |
| ESD | Charged device model | Class C3 (> 1.0 kV) (per JESD22-C101) | |
| | Human body model | 6ED003L06-F2 | Class 2 (per JEDEC standard JESD22-A114) |
| | | 6ED003L02-F2 | Class 1C (per JEDEC standard JESD22-A114) |
| RoHS compliant | | Yes | |

8 Related products

Table 10

| Gate Driver ICs | |
|---|--|
| 6EDL04I06NT/ 6EDL04I06PT 6EDL04N06PT 6EDL04N02PR | 200 V & 600 V three-phase driver with OCP, Enable, Fault and integrated high speed, low $R_{DS(ON)}$ Bootstrap Diode, +0.165 A / -0.375 A source/sink current, for MOSFET or IGBT. Evaluation board available. |
| 2EDL05I06 / 2EDL05N06 | 600 V, half-bridge thin-film SOI level shift gate driver with integrated high speed, low $R_{DS(ON)}$ bootstrap diode, 0.36/0.7 A source/sink current driver, 8pins/14pins package, for MOSFET or IGBT. |
| 2EDL23I06 / 2EDL23N06 | 600 V, half-bridge thin-film SOI gate driver with integrated high speed, low $R_{DS(ON)}$ bootstrap diode, OCP, 2.3/2.8 A source/sink current driver, and one pin Enable/Fault function for MOSFET or IGBT. |
| Power Switches | |
| IKD04N60R / RF | 600 V TRENCHSTOP™ IGBT with integrated diode in PG-T0252-3 package |
| IKD06N65ET6 | 650 V TRENCHSTOP™ IGBT with integrated diode in DPAK |
| IPD65R950CFD | 650 V CoolMOS CFD2 with integrated fast body diode in DPAK |
| IPN50R950CE | 500 V CoolMOS CE Superjunction MOSFET in PG-SOT223 package |
| iMOTION™ Controllers | |
| IRMCK099 | iMOTION™ Motor control IC for variable speed drives utilizing sensor-less Field Oriented Control (FOC) for Permanent Magnet Synchronous Motors (PMSM). |
| IMC101T | High performance Motor Control IC for variable speed drives based on field oriented control (FOC) of permanent magnet synchronous motors (PMSM). |

Revision history

| Document version | Date of release | Description of changes |
|------------------|-----------------|--|
| 2.8 | 2016-08-05 | Increased the maximum operating ambient temperature to 105 °C |
| | | Updated disclaimer, Delete links to application note |
| | | Corrected parameter V_{HO} |
| 2.9 | 2019-01-11 | Updated ESD HBM information, and add package drawing PG-TSSOP-28 |

¹ Qualification standards can be found at Infineon's web site www.infineon.com

² Higher qualification ratings may be available should the user have such requirements. Please contact your Infineon sales representative for further information.

³ Higher MSL ratings may be available for the specific package types listed here. Please contact your Infineon sales representative for further information.

Trademarks

All referenced product or service names and trademarks are the property of their respective owners.

Edition 2019-03-21

Published by

Infineon Technologies AG

81726 Munich, Germany

© 2019 Infineon Technologies AG.

All Rights Reserved.

Do you have a question about this document?

Email: erratum@infineon.com

Document reference

IMPORTANT NOTICE

The information given in this document shall in no event be regarded as a guarantee of conditions or characteristics ("Beschaffenheitsgarantie").

With respect to any examples, hints or any typical values stated herein and/or any information regarding the application of the product, Infineon Technologies hereby disclaims any and all warranties and liabilities of any kind, including without limitation warranties of non-infringement of intellectual property rights of any third party.

In addition, any information given in this document is subject to customer's compliance with its obligations stated in this document and any applicable legal requirements, norms and standards concerning customer's products and any use of the product of Infineon Technologies in customer's applications.

The data contained in this document is exclusively intended for technically trained staff. It is the responsibility of customer's technical departments to evaluate the suitability of the product for the intended application and the completeness of the product information given in this document with respect to such application.

For further information on the product, technology delivery terms and conditions and prices please contact your nearest Infineon Technologies office (www.infineon.com).

Please note that this product is not qualified according to the AEC Q100 or AEC Q101 documents of the Automotive Electronics Council.

WARNINGS

Due to technical requirements products may contain dangerous substances. For information on the types in question please contact your nearest Infineon Technologies office.

Except as otherwise explicitly approved by Infineon Technologies in a written document signed by authorized representatives of Infineon Technologies, Infineon Technologies' products may not be used in any applications where a failure of the product or any consequences of the use thereof can reasonably be expected to result in personal injury.

单击下面可查看定价，库存，交付和生命周期等信息

[>>Infineon Technologies\(英飞凌\)](#)

[>>点击查看相关商品](#)