

TLE4921-5U

Dynamic Differential Hall Effect Sensor IC

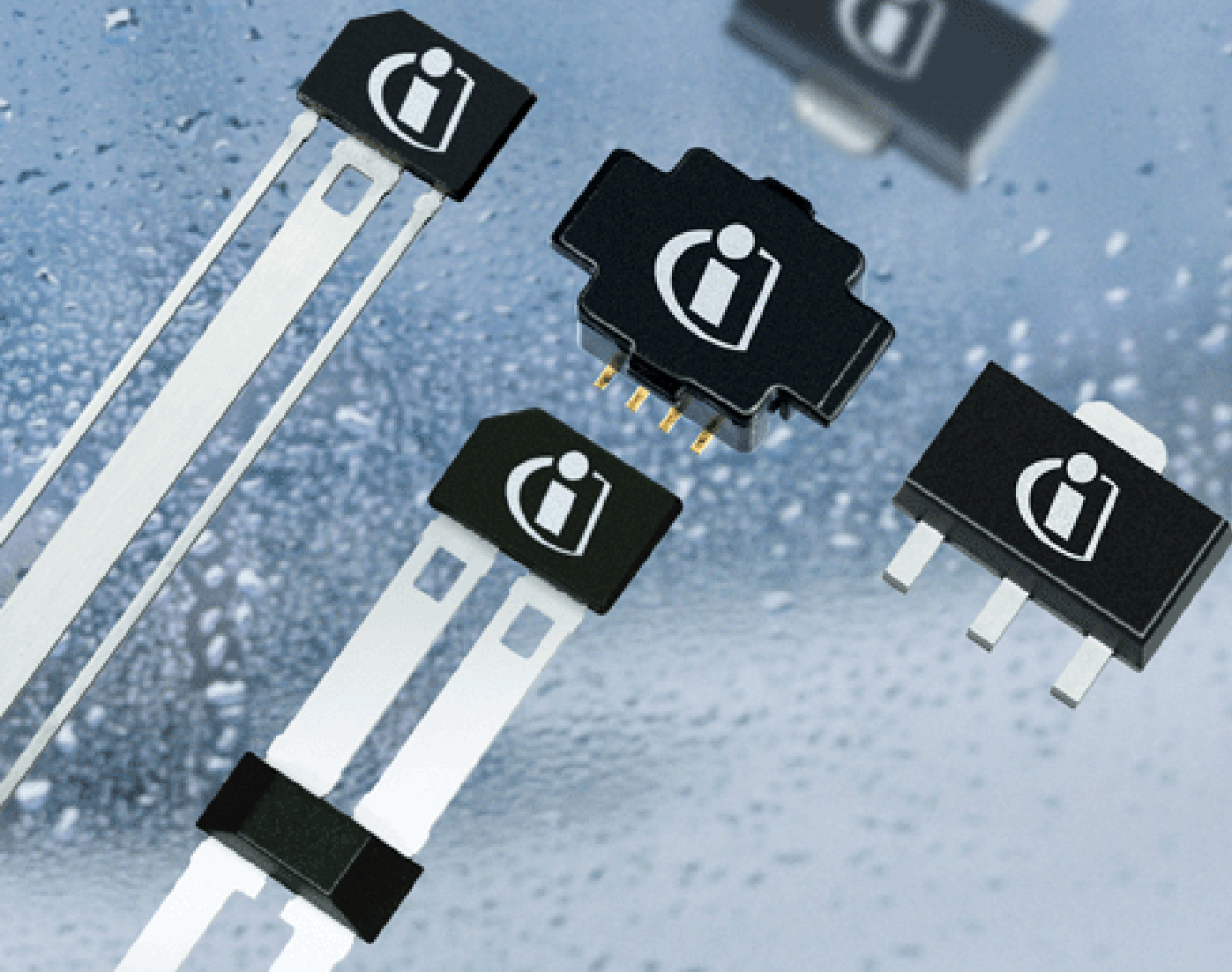

Sensors



Never stop thinking.

Edition 2008-01

**Published by Infineon Technologies AG,
St.-Martin-Strasse 53,
81669 München, Germany**

**© Infineon Technologies AG 2008.
All Rights Reserved.**

Attention please!

The information herein is given to describe certain components and shall not be considered as a guarantee of characteristics.

Terms of delivery and rights to technical change reserved.

We hereby disclaim any and all warranties, including but not limited to warranties of non-infringement, regarding circuits, descriptions and charts stated herein.

Information

For further information on technology, delivery terms and conditions and prices please contact your nearest Infineon Technologies Office (www.infineon.com).

Warnings

Due to technical requirements components may contain dangerous substances. For information on the types in question please contact your nearest Infineon Technologies Office.

Infineon Technologies Components may only be used in life-support devices or systems with the express written approval of Infineon Technologies, if a failure of such components can reasonably be expected to cause the failure of that life-support device or system, or to affect the safety or effectiveness of that device or system. Life support devices or systems are intended to be implanted in the human body, or to support and/or maintain and sustain and/or protect human life. If they fail, it is reasonable to assume that the health of the user or other persons may be endangered.

Revision History: 2008-01

V 1.1

Previous Version: V1.0

Page	Subjects (major changes since last revision)
5	Ordering Code changed
11	“Output leakage current” unit corrected
20	Figures “Delay Time between Switching Threshold” exchanged and corrected
21	Figure “Delay Time versus Differential Field” corrected

We Listen to Your Comments

Any information within this document that you feel is wrong, unclear or missing at all? Your feedback will help us to continuously improve the quality of this document. Please send your proposal (including a reference to this document) to:

sensors@infineon.com

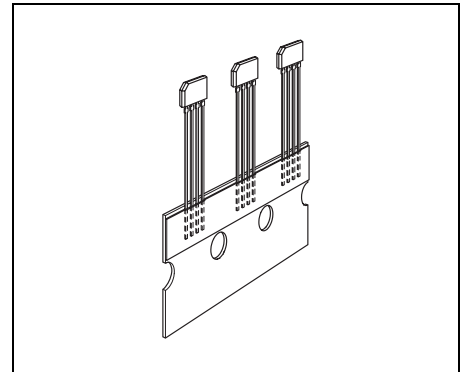

Table of Contents		Page
1	Overview	5
1.1	Features	5
1.2	Pin Configuration (view on branded side of component)	6
2	General	7
2.1	Block Diagram	7
2.2	Functional Description	8
2.3	Circuit Description (see Figure 2)	8
3	Maximum Ratings	9
4	Operating Range	10
5	Electrical and Magnetic Parameters	11
6	Application Configurations	14
7	Typical Performance Characteristics	18
8	Package Outlines	25

1 Overview

1.1 Features

- Advanced performance
- High sensitivity
- Symmetrical thresholds
- High piezo resistivity
- Reduced power consumption
- South and north pole pre-induction possible
- AC coupled
- Digital output signal
- Two-wire and three-wire configuration possible
- Large temperature range
- Large airgap
- Low cut-off frequency
- Protection against overvoltage
- Protection against reversed polarity
- Output protection against electrical disturbances



The differential Hall Effect sensor TLE4921-5U provides a high sensitivity and a superior stability over temperature and symmetrical thresholds in order to achieve a stable duty cycle. TLE4921-5U is particularly suitable for rotational speed detection and timing applications of ferromagnetic toothed wheels such as anti-lock braking systems, transmissions, crankshafts, etc. The integrated circuit (based on Hall effect) provides a digital signal output with frequency proportional to the speed of rotation. Unlike other rotational sensors differential Hall ICs are not influenced by radial vibration within the effective airgap of the sensor and require no external signal processing.

Type	Marking	Ordering Code	Package
TLE4921-5U	215U	SP000013593	PG-SSO-4-1

1.2 Pin Configuration (view on branded side of component)

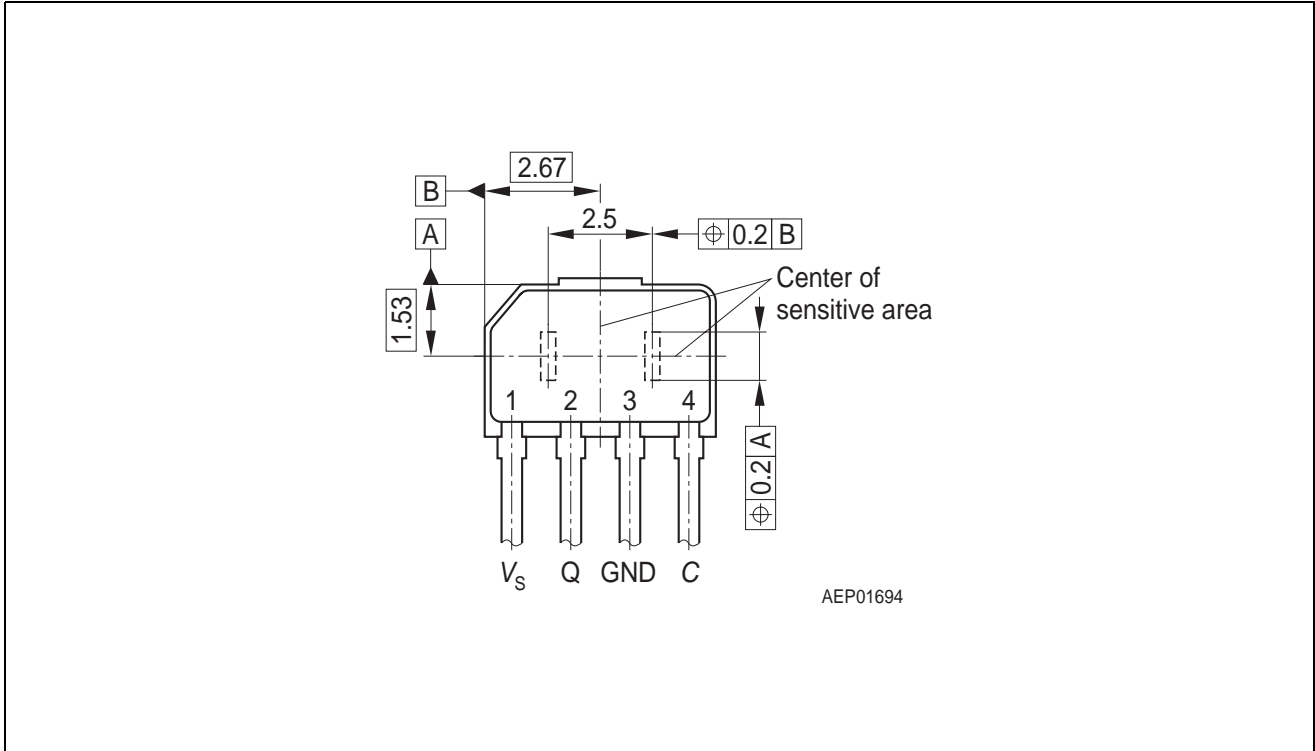

Figure 1

Table 1 Pin Definitions and Functions

Pin No.	Symbol	Function
1	V_S	Supply voltage
2	Q	Output
3	GND	Ground
4	C	Capacitor

2 General

2.1 Block Diagram

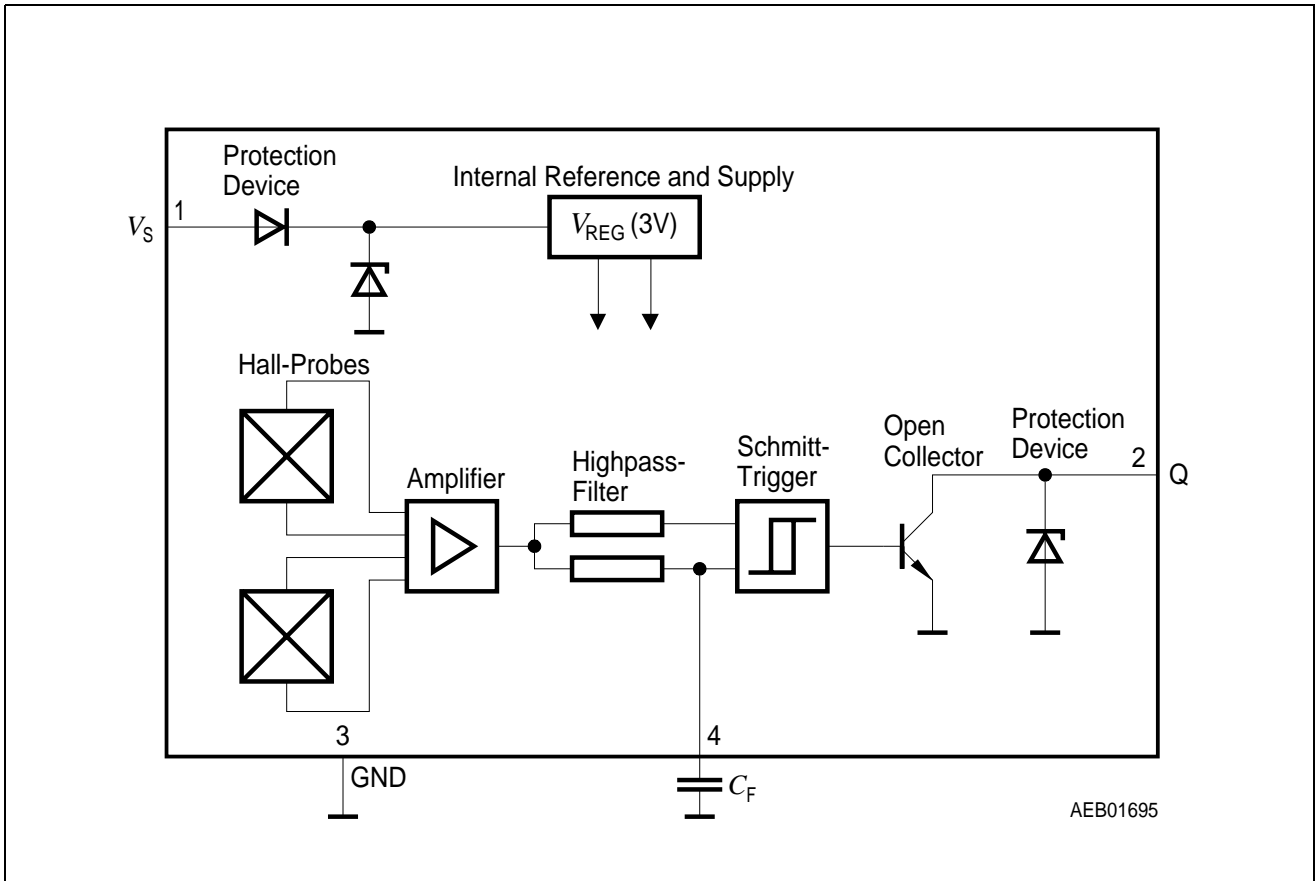

Figure 2 Block Diagram

2.2 Functional Description

The Differential Hall Sensor IC detects the motion and position of ferromagnetic and permanent magnet structures by measuring the differential flux density of the magnetic field. To detect ferromagnetic objects the magnetic field must be provided by a back biasing permanent magnet (**south or north** pole of the magnet attached to the rear unmarked side of the IC package).

Using an external capacitor the generated Hall voltage signal is slowly adjusted via an active high pass filter with a low cut-off frequency. This causes the output to switch into a biased mode after a time constant is elapsed. The time constant is determined by the external capacitor. Filtering avoids ageing and temperature influence from Schmitt-trigger input and eliminates device and magnetic offset.

The TLE4921-5U can be exploited to detect toothed wheel rotation in a rough environment. Jolts against the toothed wheel and ripple have no influence on the output signal.

Furthermore, the TLE4921-5U can be operated in a two-wire as well as in a three-wire-configuration.

The output is logic compatible by high/low levels regarding on and off.

2.3 Circuit Description (see [Figure 2](#))

The TLE4921-5U is comprised of a supply voltage reference, a pair of Hall probes spaced at 2.5 mm, differential amplifier, filter for offset compensation, Schmitt trigger, and an open collector output.

The TLE4921-5U was designed to have a wide range of application parameter variations. Differential fields up to ± 80 mT can be detected without influence to the switching performance. The pre-induction field can either come from a magnetic south or north pole, whereby the field strength up to 500 mT or more will not influence the switching points. The improved temperature compensation enables a superior sensitivity and accuracy over the temperature range. Finally the optimized piezo compensation and the integrated dynamic offset compensation enable easy manufacturing and elimination of magnet offsets.

Protection is provided at the input/supply (pin 1) for overvoltage and reverse polarity and against over-stress such as load dump, etc., in accordance with ISO-TR 7637 and DIN 40839. The output (pin 2) is protected against voltage peaks and electrical disturbances.

Maximum Ratings

3 Maximum Ratings

Table 2 Absolute Maximum Ratings
 $T_j = -40^{\circ}\text{C to } 150^{\circ}\text{C}$

Parameter	Symbol	Limit Values		Unit	Remarks
		min.	max.		
Supply voltage	V_S	-35 ¹⁾	30	V	
Output voltage	V_Q	-0.7	30	V	
Output current	I_Q	–	50	mA	
Output reverse current	$-I_Q$	–	50	mA	
Capacitor voltage	V_C	-0.3	3	V	
Junction temperature	T_j	–	150	°C	5000 h
		–	160		2500 h
		–	170		1000 h
		–	210		40 h
Storage temperature	T_S	-40	150	°C	
Thermal resistance PG-SSO-4-1	R_{thJA}	–	190	K/W	
Current through input-protection device	I_{SZ}	–	200	mA	$t < 2 \text{ ms}; v = 0.1$
Current through output-protection device	I_{QZ}	–	200	mA	$t < 2 \text{ ms}; v = 0.1$

1) Reverse current < 10 mA

4 Operating Range

Table 3 ESD Protection
Human Body Model (HBM) tests according to:
Standard EIA/JESD22-A114-B HBM

Parameter	Symbol	Limit Values		Unit	Remarks
		min.	max.		
ESD - protection	V_{ESD}	–	± 2	kV	

Table 4 Operating Range

Parameter	Symbol	Limit Values			Unit	Remarks
		min.	typ.	max.		
Supply voltage	V_S	4.5	–	24	V	
Junction temperature	T_j	-40	–	150	°C	5000 h
		–	–	160		2500 h
		–	–	170		1000 h
Pre-induction	B_0	-500	–	500	mT	at Hall probe; independent of magnet orientation
Differential induction	ΔB	-80	–	80	mT	

Note: In the operating range the functions given in the circuit description are fulfilled.

Electrical and Magnetic Parameters
5 Electrical and Magnetic Parameters
Table 5 Electrical Characteristics

Parameter	Symbol	Limit Values			Unit	Test Condition	Test Circuit
		min.	typ.	max.			
Supply current	I_S	3.8	5.3	8.0	mA	$V_Q = \text{high}$ $I_Q = 0 \text{ mA}$	1
		4.3	5.9	8.8	mA	$V_Q = \text{low}$ $I_Q = 40 \text{ mA}$	1
Output saturation voltage	V_{QSAT}	–	0.25	0.6	V	$I_Q = 40 \text{ mA}$	1
Output leakage current	I_{QL}	–	–	50	μA	$V_Q = 24 \text{ V}$	1
Center of switching points: ($\Delta B_{OP} + \Delta B_{RP}$) / 2	ΔB_m	-1	0	1	mT	$-20 \text{ mT} < \Delta B < 20 \text{ mT}^{1) 2)}$ $f = 200 \text{ Hz}$	2
Operate point	ΔB_{OP}	–	–	0	mT	$f = 200 \text{ Hz}$, $\Delta B = 20 \text{ mT}$	2
Release point	ΔB_{RP}	0	–	–	mT	$f = 200 \text{ Hz}$, $\Delta B = 20 \text{ mT}$	2
Hysteresis	ΔB_H	0.5	1.5	2.5	mT	$f = 200 \text{ Hz}$, $\Delta B = 20 \text{ mT}$	2
Overvoltage protection at supply voltage at output	V_{SZ}	27	–	35	V	$I_S = 16 \text{ mA}$	1
	V_{QZ}	27	–	35	V	$I_Q = 16 \text{ mA}$	1
Output rise time	t_r	–	–	0.5	μs	$I_Q = 40 \text{ mA}$ $C_L = 10 \text{ pF}$	1
Output fall time	t_f	–	–	0.5	μs	$I_Q = 40 \text{ mA}$ $C_L = 10 \text{ pF}$	1
Delay time	t_{dop}	–	–	25	μs	$f = 10 \text{ kHz}$ $\Delta B = 5 \text{ mT}$	2
	t_{drp}	–	–	10	μs		
	$t_{dop} - t_{drp}$	–	0	15	μs		
Filter input resistance	R_C	35	43	52	k Ω	$25^\circ\text{C} \pm 2^\circ\text{C}$	1

Electrical and Magnetic Parameters

Table 5 Electrical Characteristics (cont'd)

Parameter	Symbol	Limit Values			Unit	Test Condition	Test Circuit
		min.	typ.	max.			
Filter sensitivity to ΔB	S_C	–	-5	–	mV/mT	–	1
Filter bias voltage	V_C	1.6	2	2.4	V	$\Delta B = 0$	1
Frequency	f	³⁾	–	20000	Hz	$\Delta B = 5 \text{ mT}$	2
Resistivity against mechanical stress (piezo)	ΔB_m	-0.1	–	0.1	mT	F = 2 N	2 ⁴⁾
	ΔB_H	-0.1	–	0.1	mT		

- 1) The Current consumption characteristic will be different and the specified values can slightly change
- 2) Leakage currents at pin 4 should be avoided. The bias shift of B_m caused by a leakage current I_L can be

calculated by:
$$\Delta B_m = \frac{I_L \times R_C(T)}{S_C(T)}$$

- 3) For higher ΔB the values may exceed the limits like following $|\Delta B_m| < |0.05 \times \Delta B|$
- 4) Depends on filter capacitor C_F . The cut-off frequency is given by $f = \frac{1}{2\pi \times R_C \times C_F}$. The switching points are

guaranteed over the whole frequency range, but amplitude modification and phase shift due to the 1st order highpass filter have to be taken into account.

Note: The listed characteristics are ensured over the operating range of the integrated circuit. Typical characteristics specify mean values expected over the production spread. If not otherwise specified, typical characteristics apply at $T_j = 25^\circ\text{C}$ and the given supply voltage.

Electrical and Magnetic Parameters

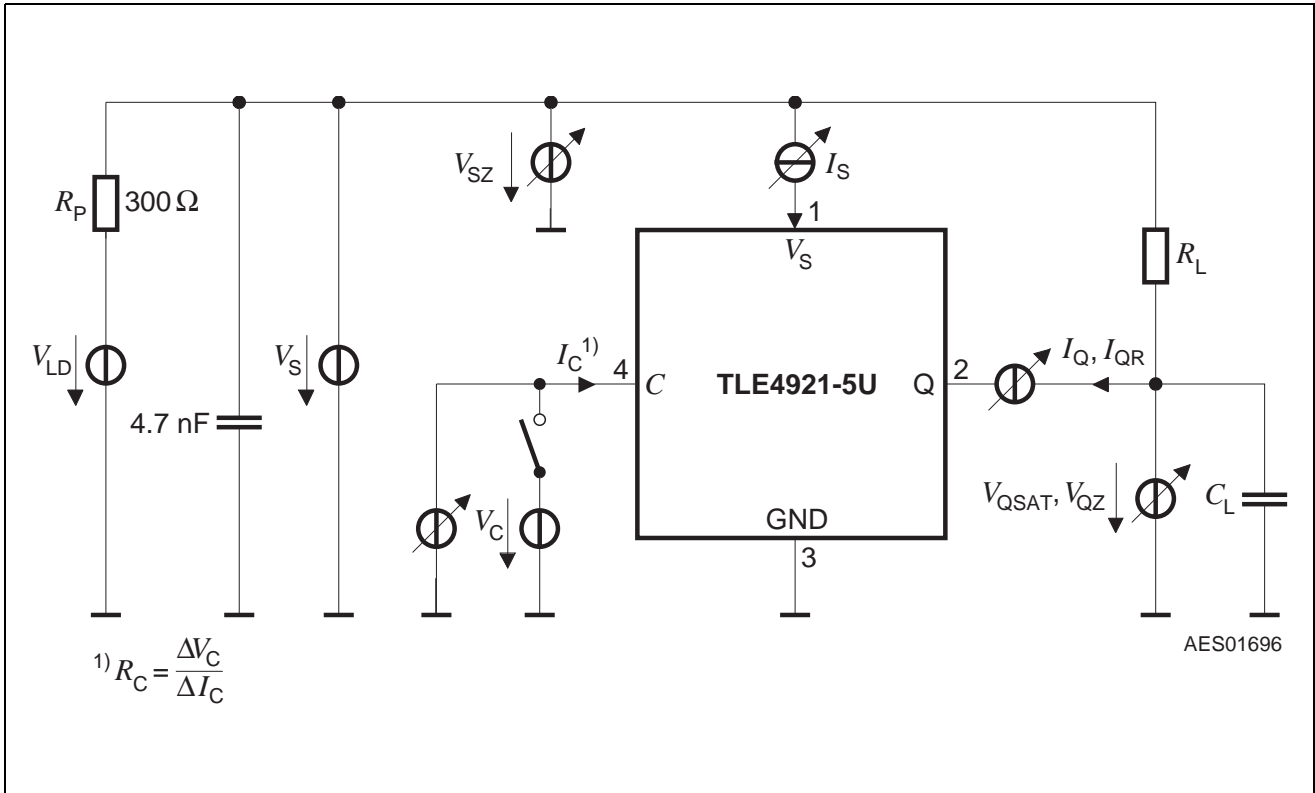

Figure 3 Test Circuit 1

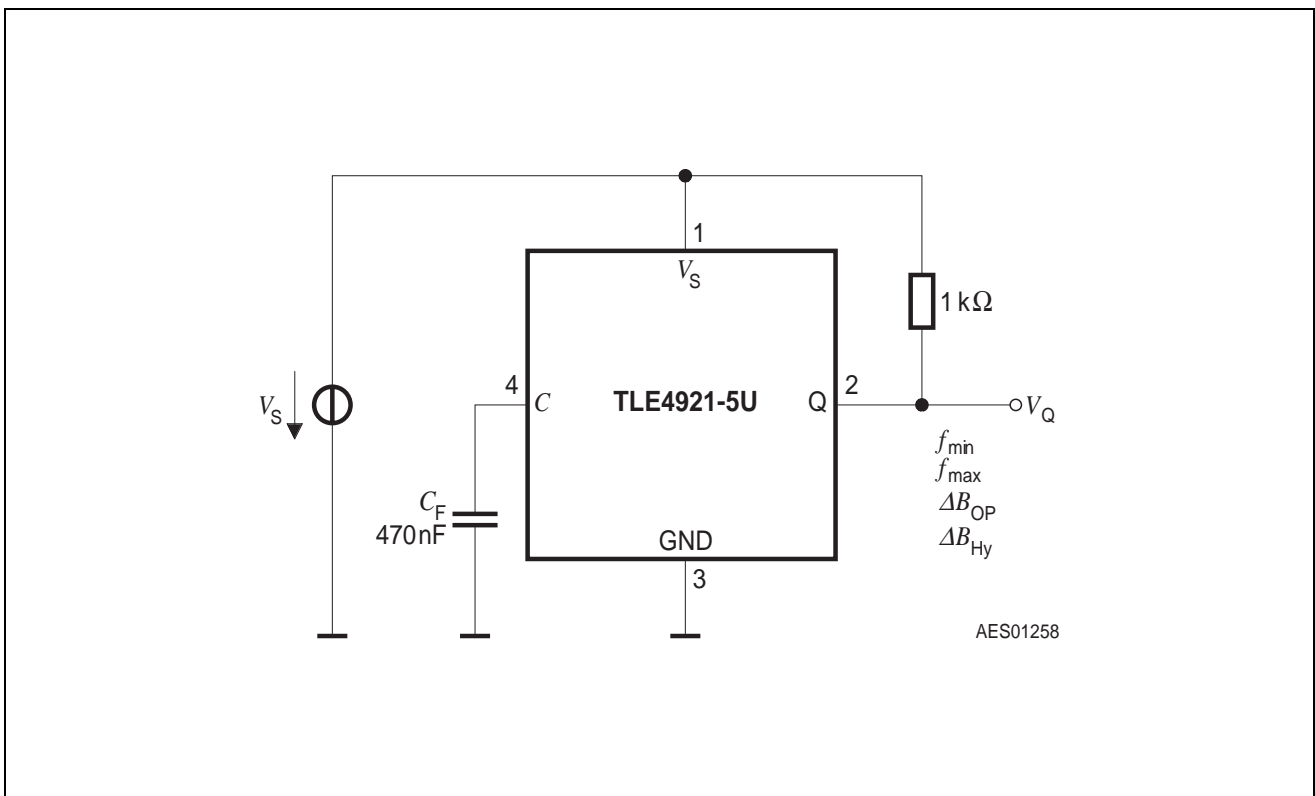

Figure 4 Test Circuit 2

6 Application Configurations

Two possible applications are shown in **Figure 7** and **Figure 8** (Toothed and Magnet Wheel). The difference between two-wire and three-wire application is shown in **Figure 9**.

Gear Tooth Sensing

In the case of ferromagnetic toothed wheel application the IC has to be biased by the south or north pole of a permanent magnet (e.g. SmCO₅ (Vacuumschmelze VX145)) with the dimensions 8 mm × 5 mm × 3 mm) which should cover both Hall probes.

The maximum air gap depends on:

- the magnetic field strength (magnet used; pre-induction) and
- the toothed wheel that is used (dimensions, material, etc.; resulting differential field)

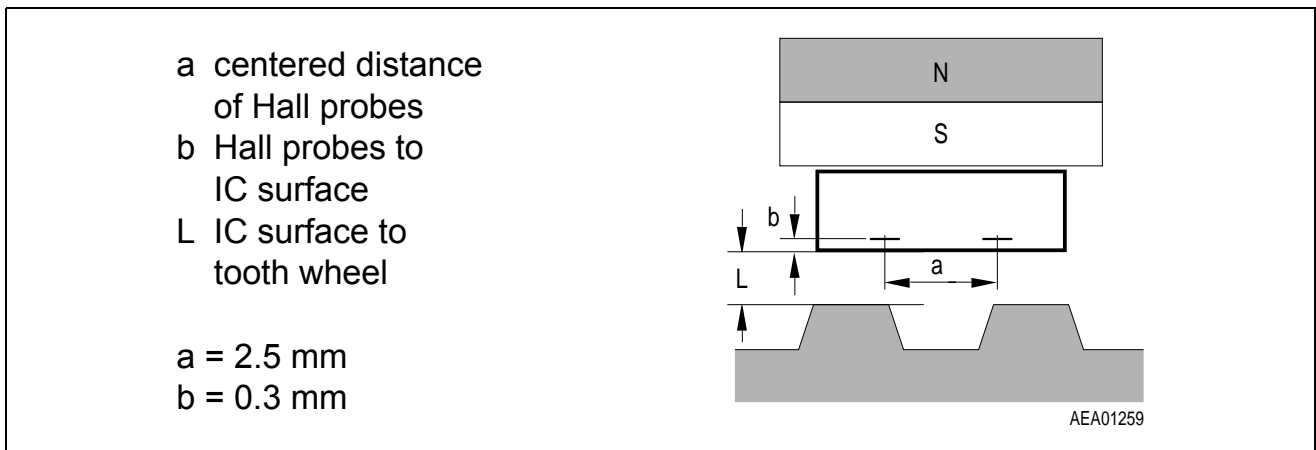

Figure 5 Sensor Spacing

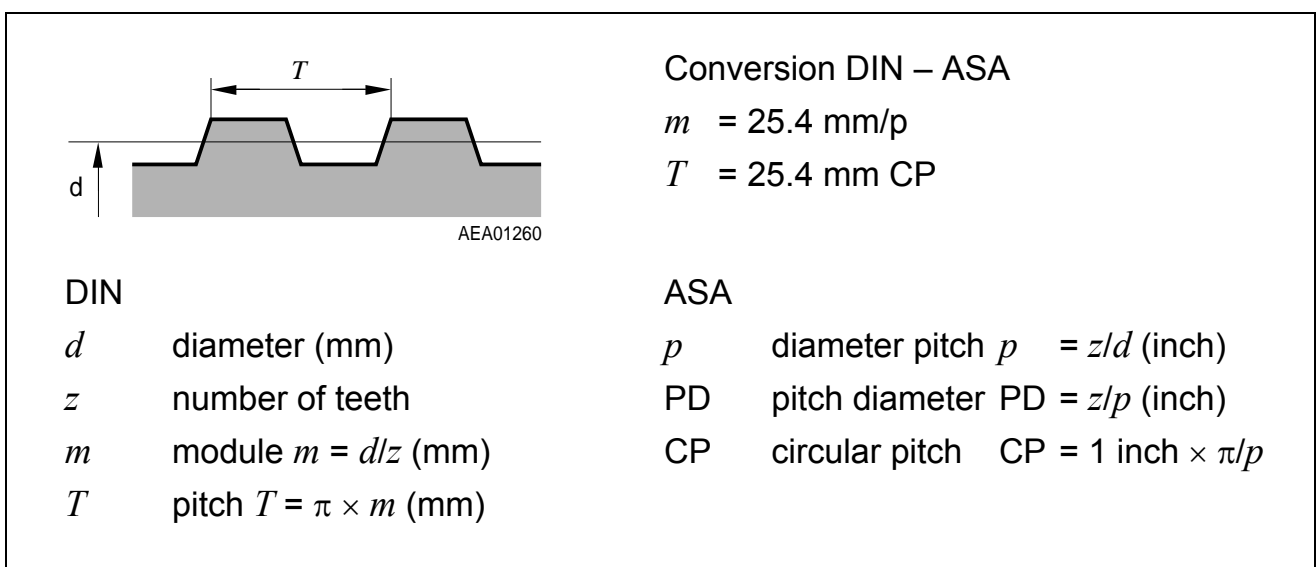

Figure 6 Tooth Wheel Dimensions

Application Configurations

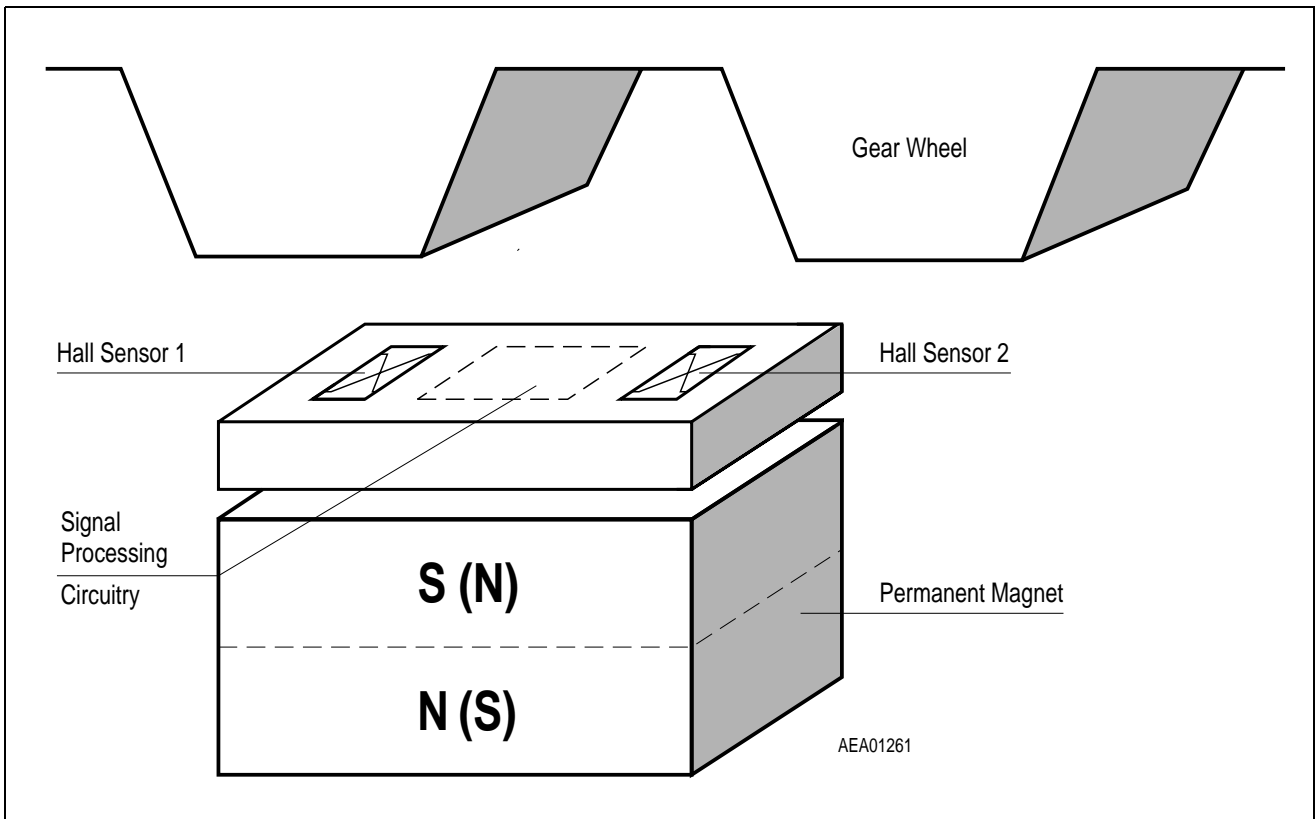

Figure 7 TLE4921-5U, with Ferromagnetic Toothed Wheel

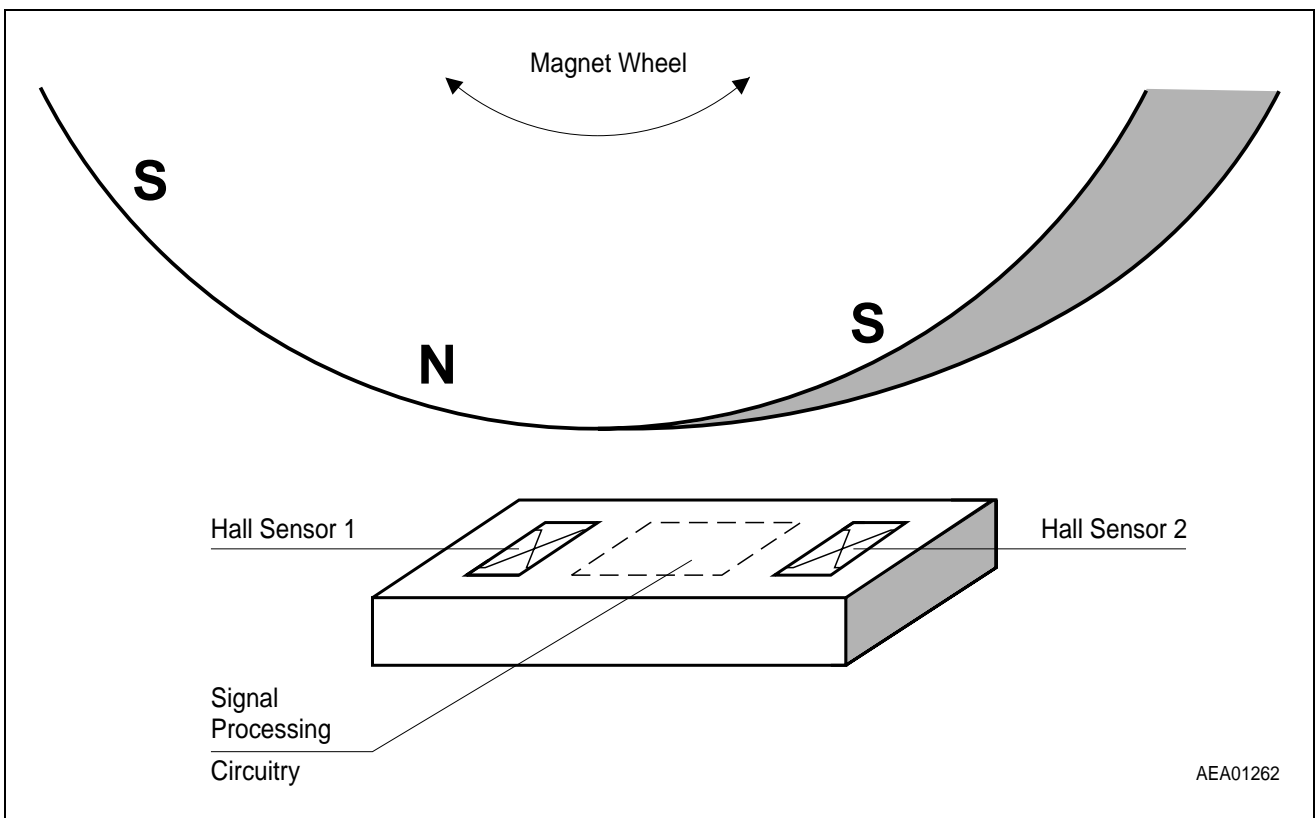
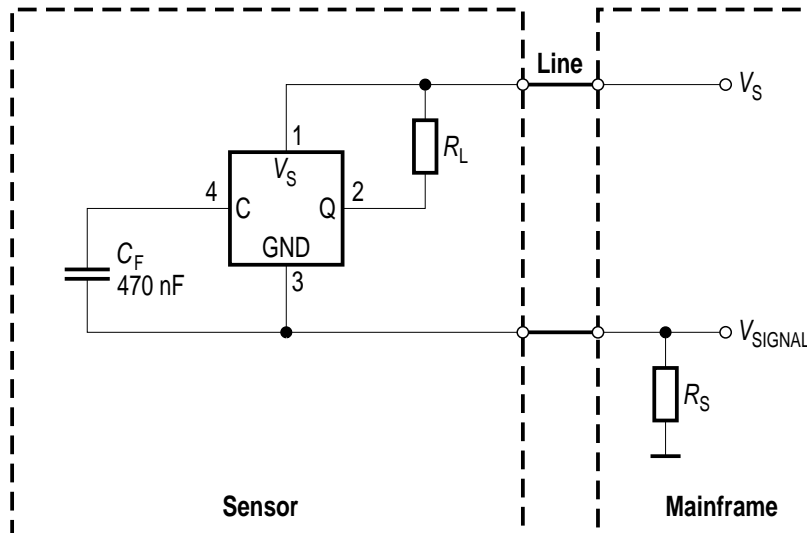

Figure 8 TLE4921-5U, with Magnet Wheel

Application Configurations

Two-wire-application



for example : $R_L = 330 \Omega$
 $R_S = 120 \Omega$

AES01263

Three-wire-application

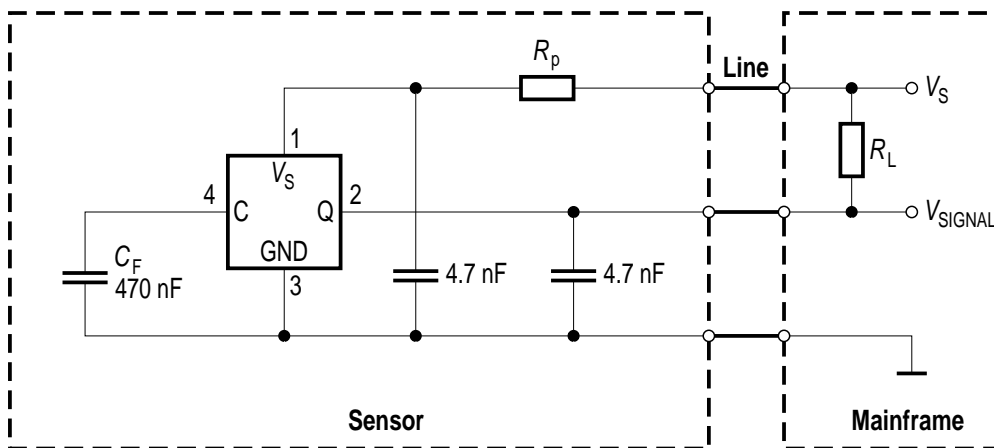

for example : $R_L = 330 \Omega$
 $R_P = 0 \dots 330 \Omega$

AES01264

Figure 9 Application Circuits

Application Configurations

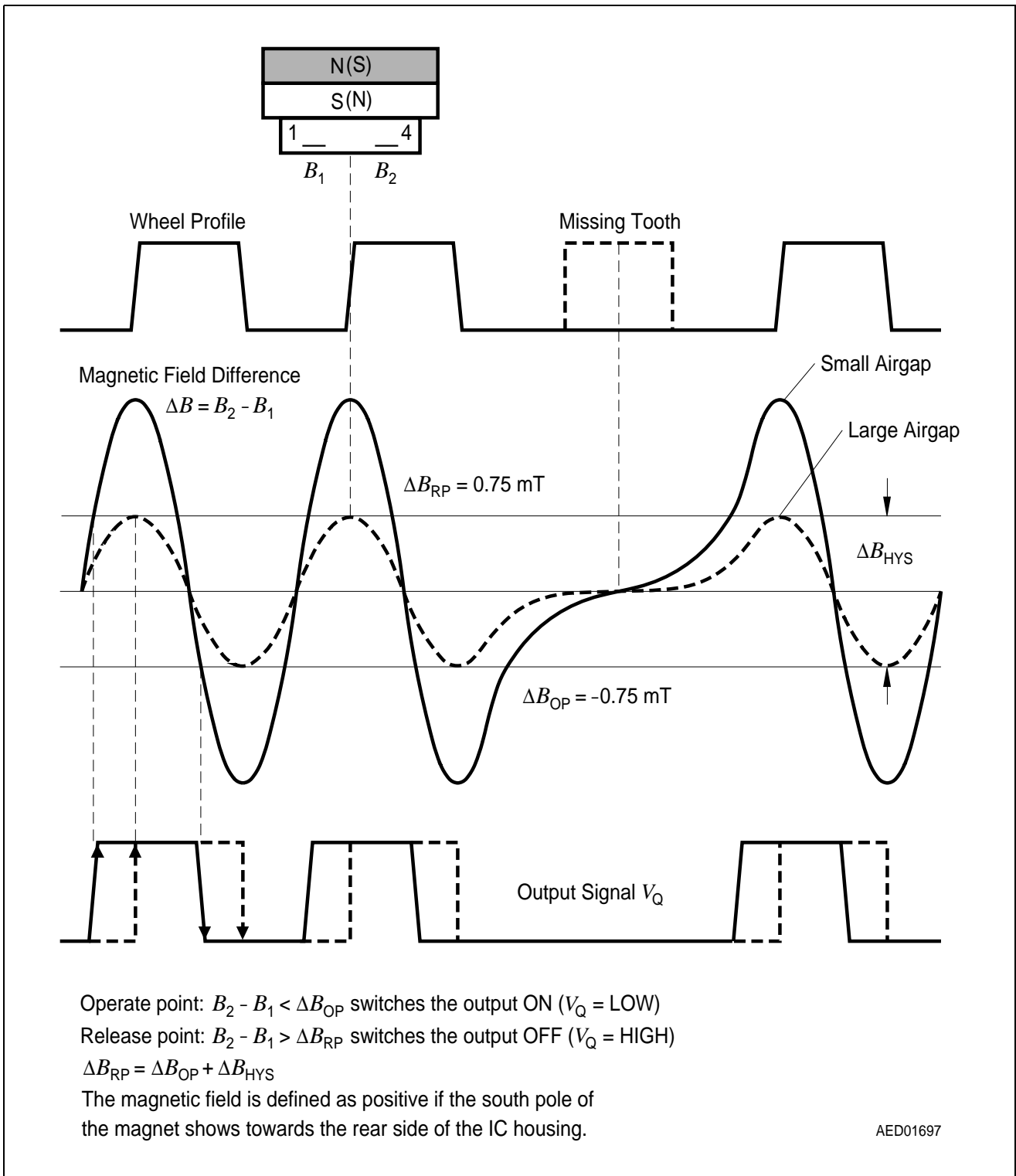
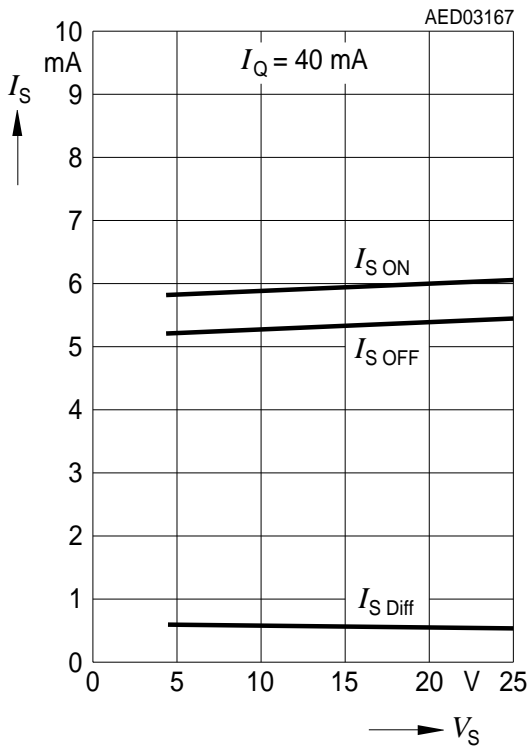

Figure 10 System Operation

Typical Performance Characteristics

7 Typical Performance Characteristics

Quiescent Current versus Supply Voltage



Quiescent Current versus Temperature

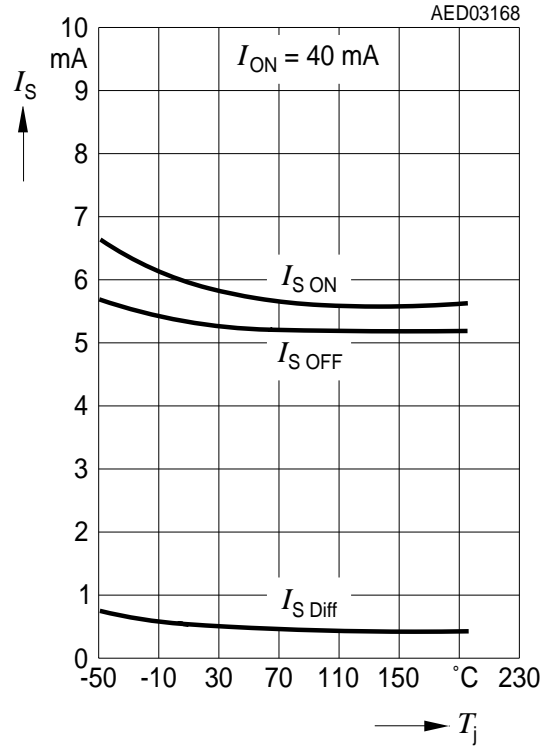

Quiescent Current versus Output Current

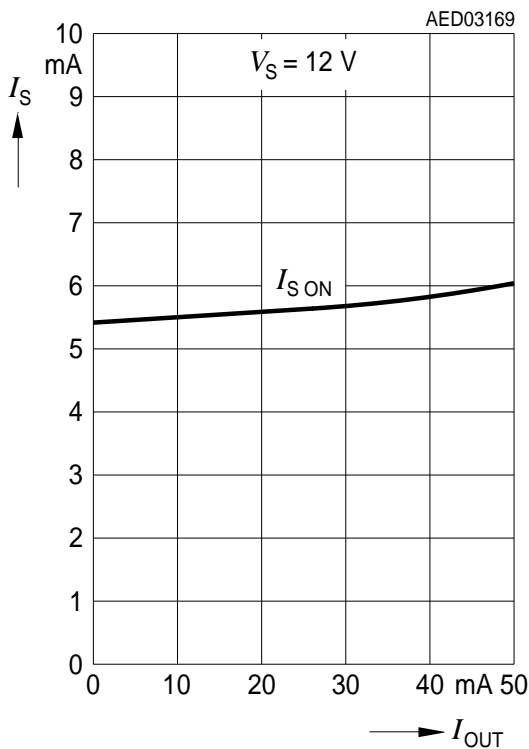

Saturation Voltage versus Temperature

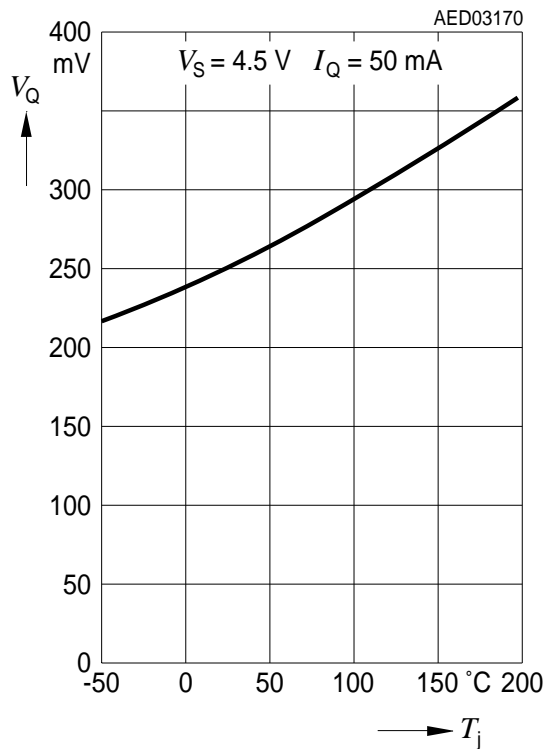

Typical Performance Characteristics

Output Saturation Voltage versus I_Q @ 25°C T_j

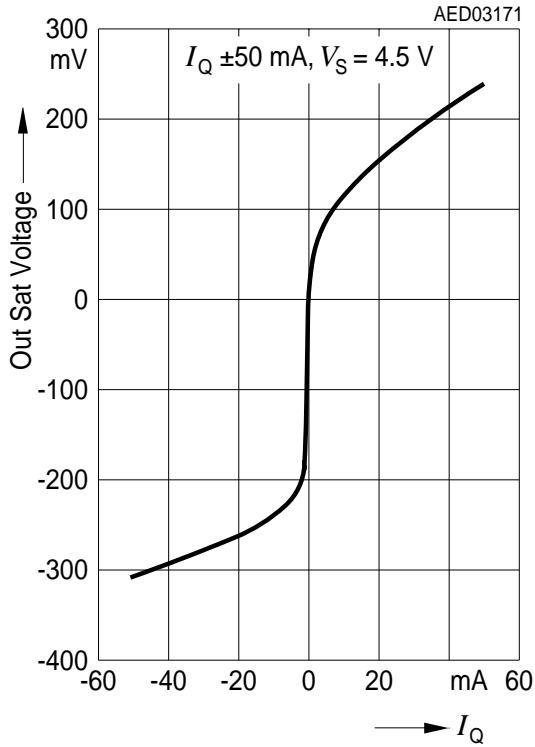

Saturation Voltage versus Supply Voltage

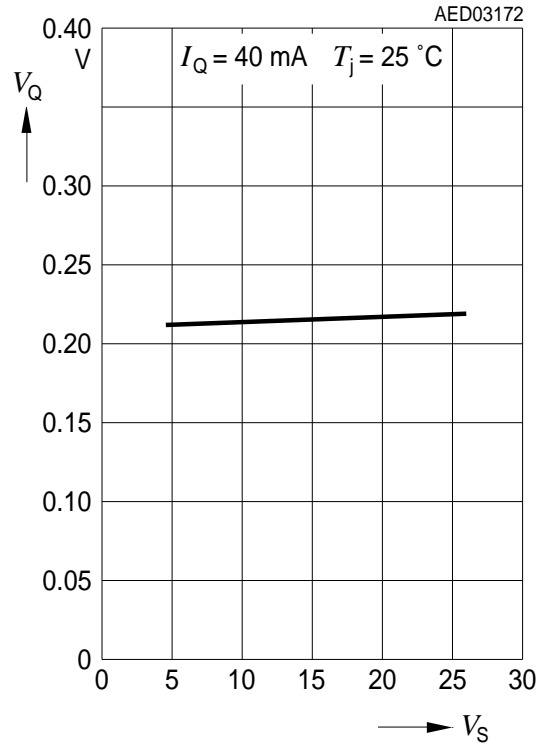

Center of Switching Points versus Temperature

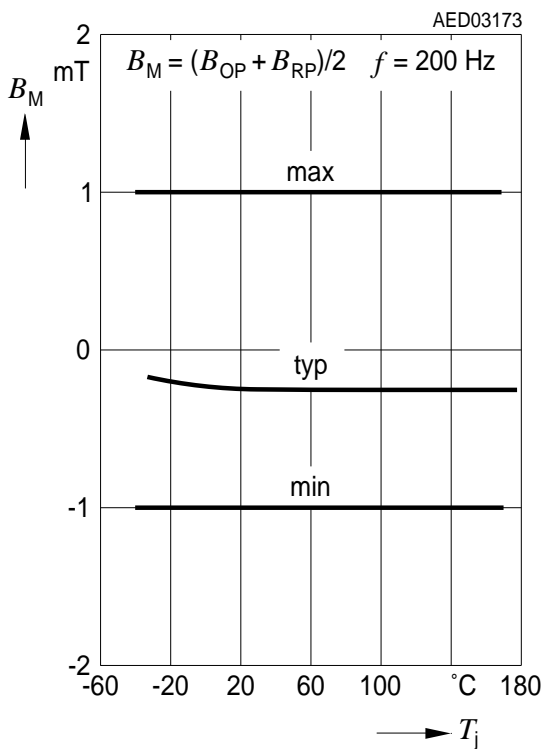

Hysteresis versus Temperature

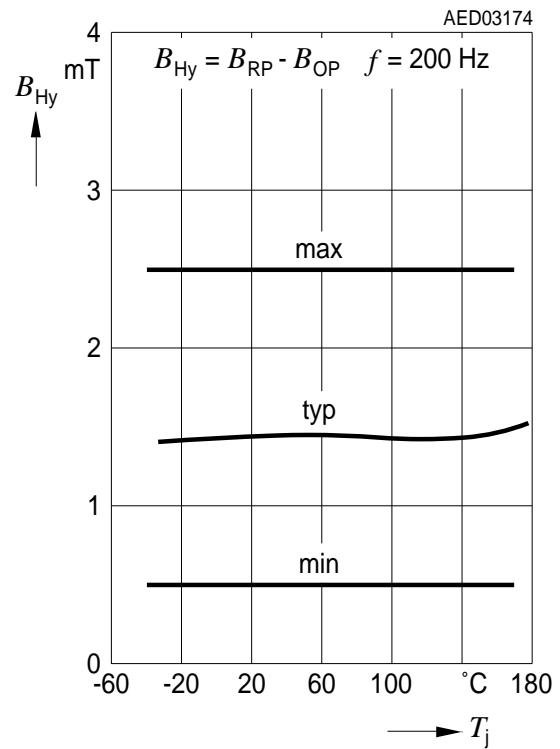

Typical Performance Characteristics

Minimum Switching Field versus Frequency

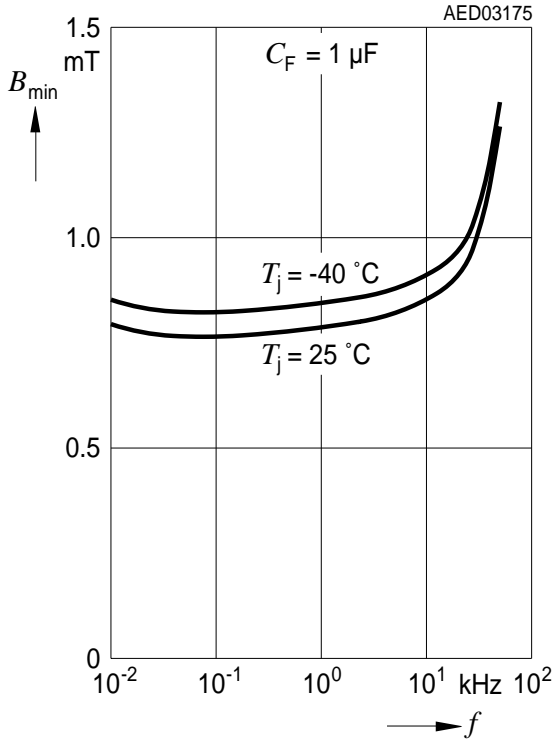

Minimum Switching Field versus Frequency

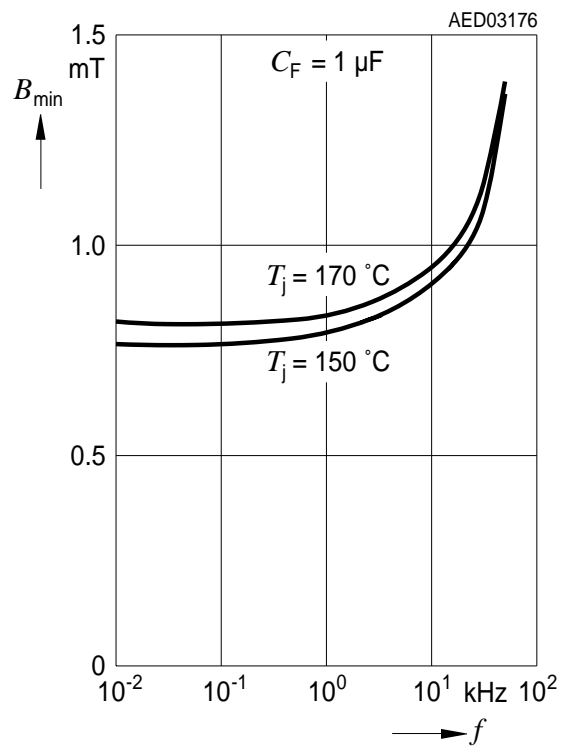

Delay Time between Switching Threshold ΔB and Falling Edge of V_{OUT} at $T_j = 25^\circ\text{C}$

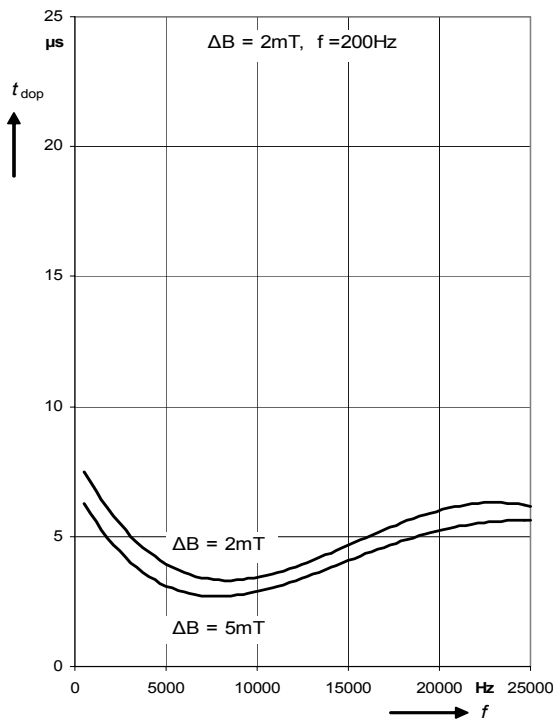

Delay Time between Switching Threshold ΔB and Rising Edge of V_{OUT} at $T_j = 25^\circ\text{C}$

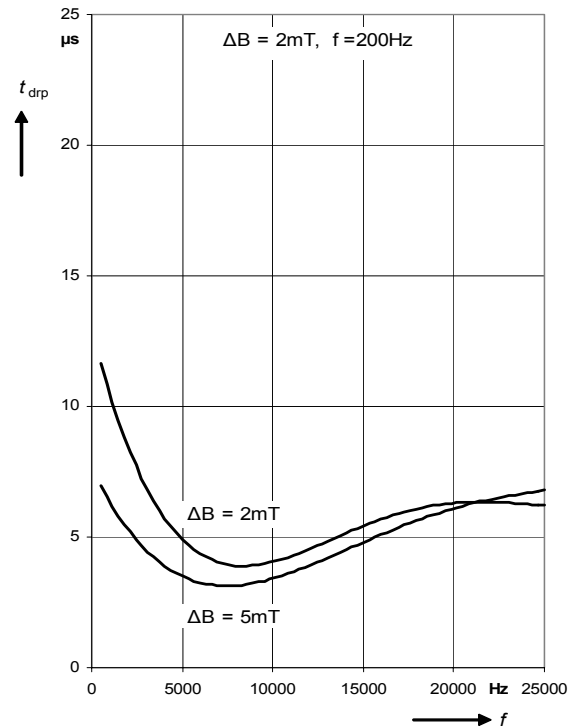

Typical Performance Characteristics

Delay Time versus Differential Field

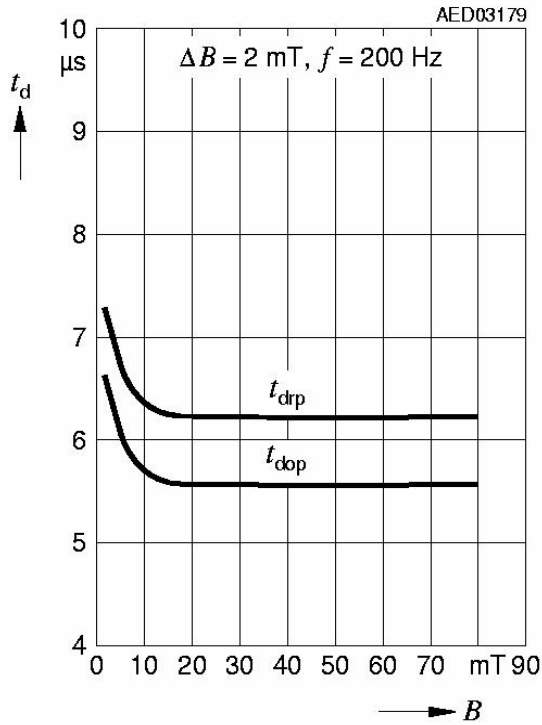

Delay Time versus Temperature

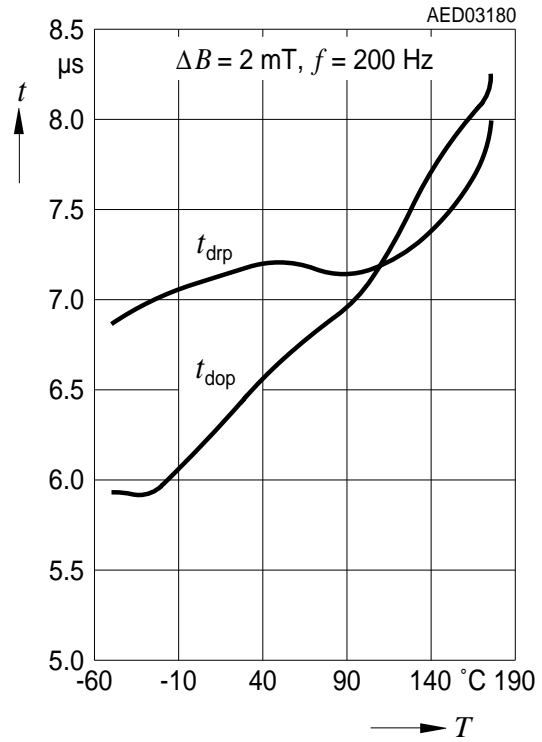

Rise and Fall Time versus Temperature

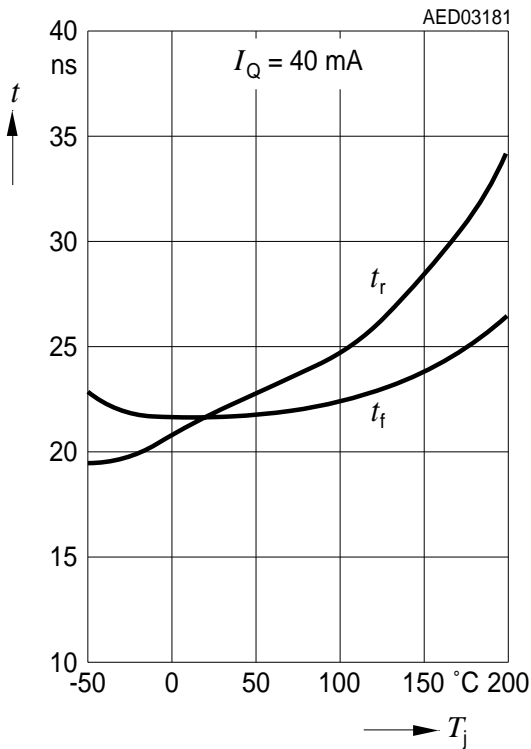

Rise and Fall Time versus Output Current

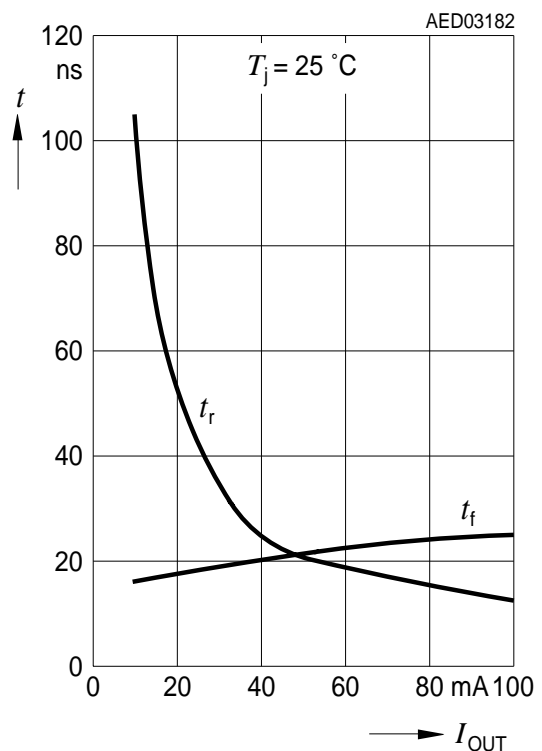

Typical Performance Characteristics

Capacitor Voltage versus Temperature

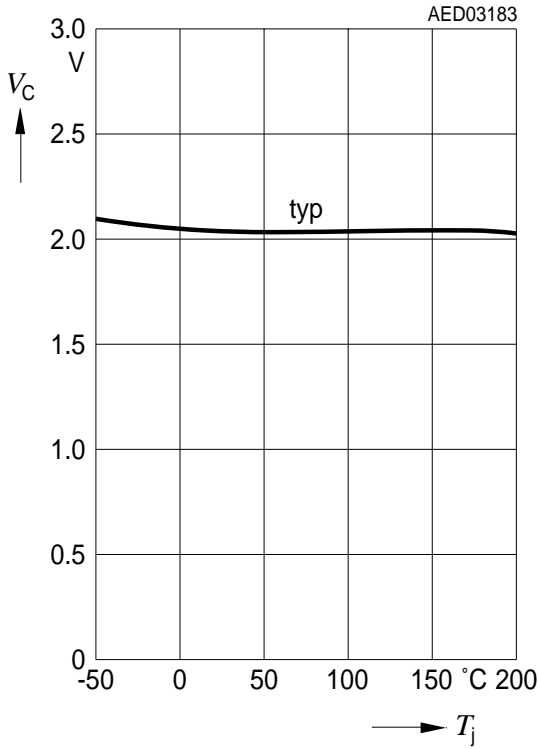

Switching Thresholds versus Mechanical Stress

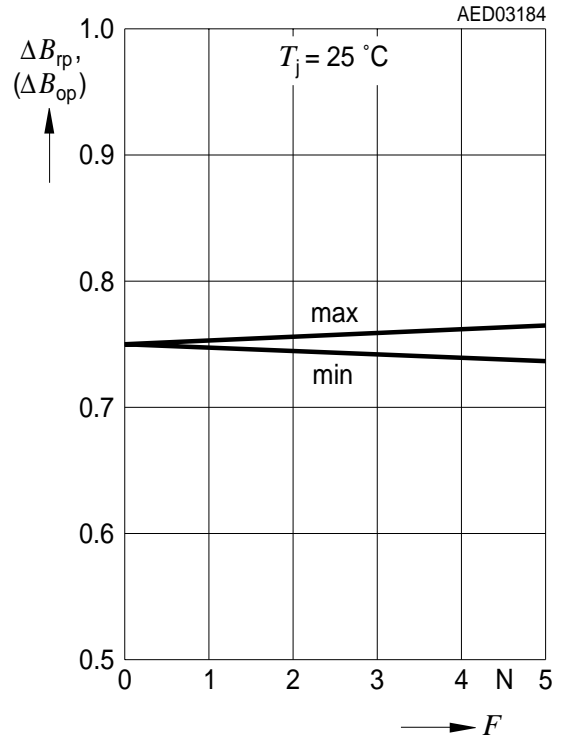

Filter Sensitivity versus Temperature

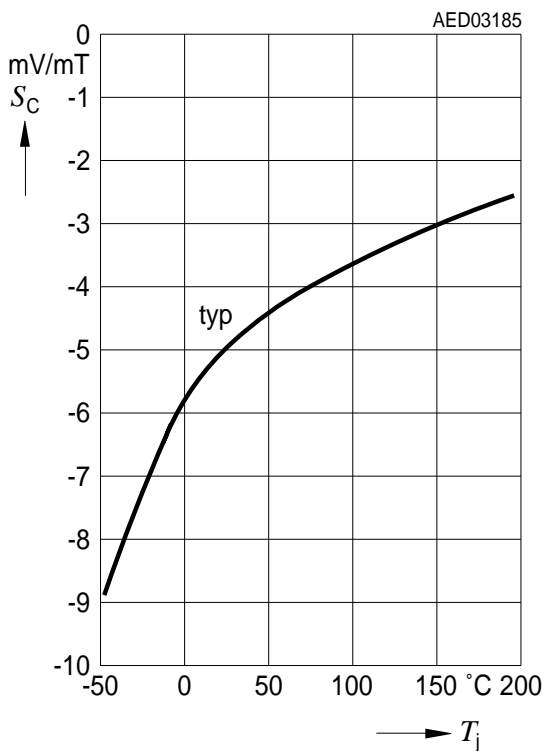

Filter Input Resistance versus Temperature

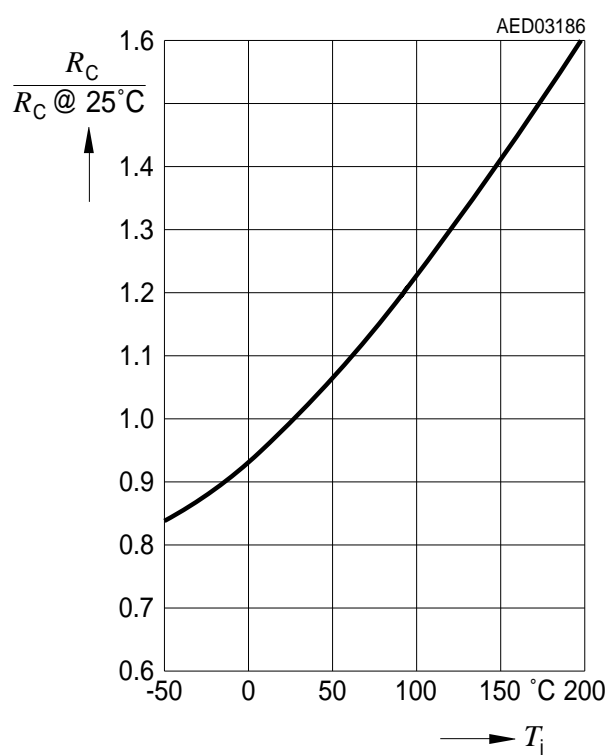

Typical Performance Characteristics

Delay Time for Power on (V_S Switching from 0 V to 4.5 V) t_{pon} versus Temp.

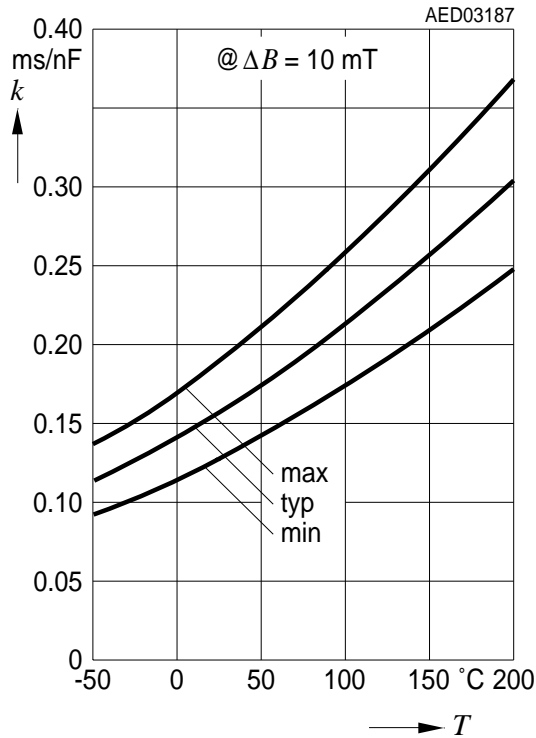

Periodjitter (1σ) versus Temperature

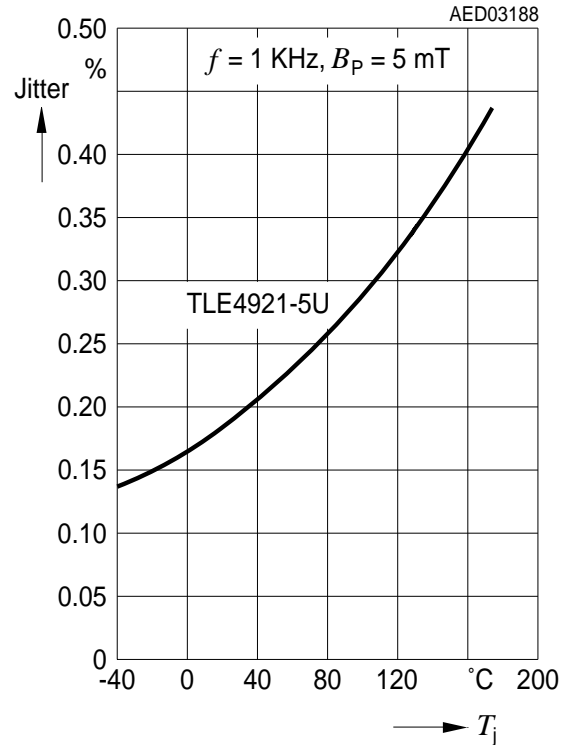

Table 6 Electro Magnetic Compatibility
ref. DIN 40839 part 1; test circuit 1

Parameter	Symbol	Level/Typ	Status
Testpulse 1	V_{LD}	IV / - 100 V	C
Testpulse 2		IV / 100 V	B
Testpulse 3a		IV / - 150 V	C
Testpulse 3b		IV / 100 V	C
Testpulse 4		IV / - 7 V	C
Testpulse 5		IV / 86.5 V	C

Note: Stresses above those listed here may cause permanent damage to the device. Exposure to absolute maximum rating conditions for extended periods may affect device reliability.

Typical Performance Characteristics

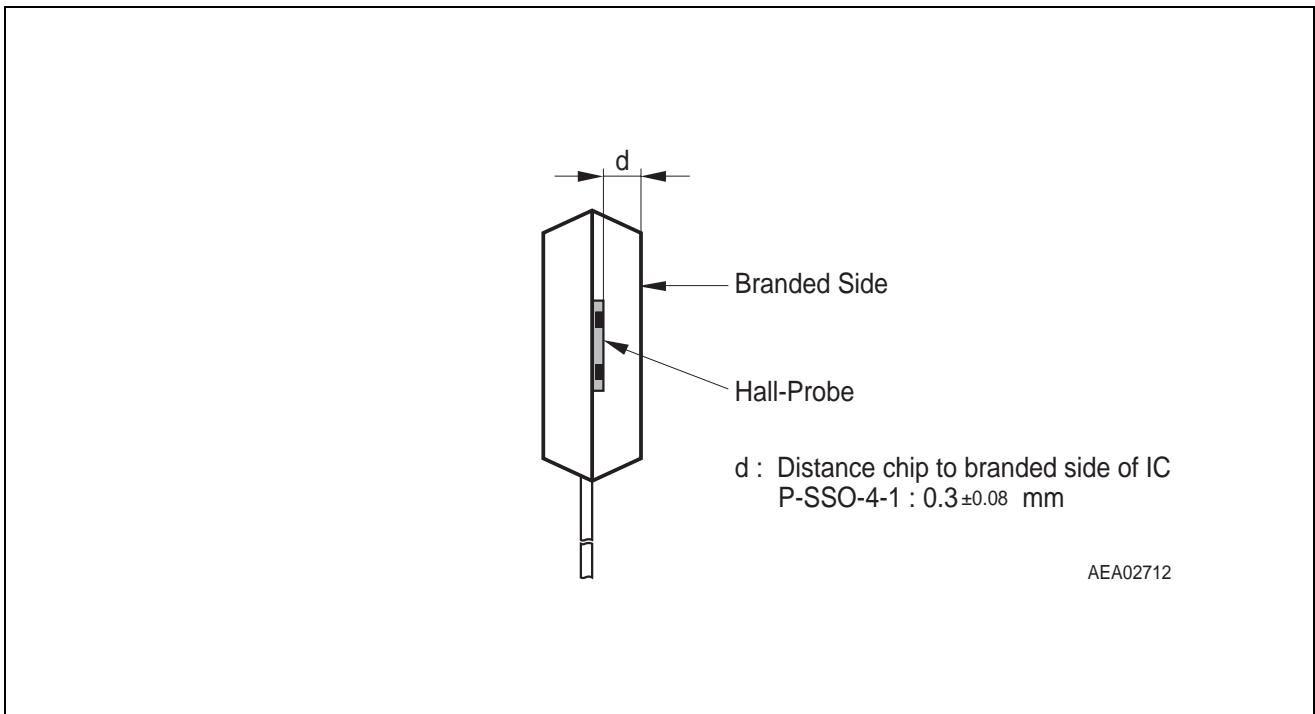

Figure 11 Distance Chip to Upper Side of IC

8 Package Outlines

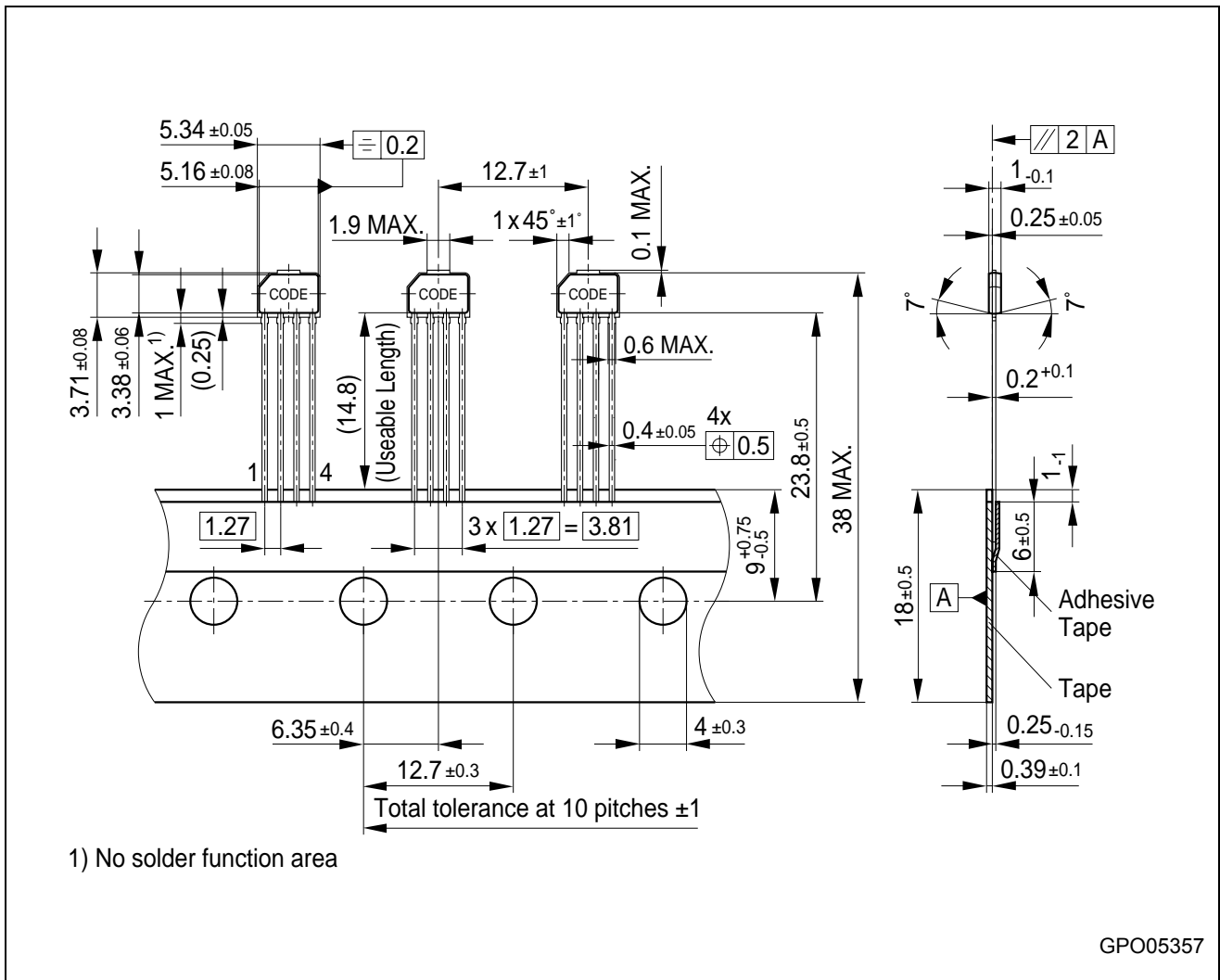

Figure 12 PG-SSO-4-1 (Plastic Single Small Outline Package)

You can find all of our packages, sorts of packing and others in our Infineon Internet Page "Products": <http://www.infineon.com/products>.

Dimensions in mm

www.infineon.com

Published by Infineon Technologies AG

Downloaded From [Oneyac.com](https://www.oneyac.com)

单击下面可查看定价，库存，交付和生命周期等信息

[>>Infineon Technologies\(英飞凌\)](#)

[>>点击查看相关商品](#)