



Pin Configuration and Functionality

Table of Contents

<b>1</b>	<b>Pin Configuration and Functionality .....</b>	<b>3</b>
<b>2</b>	<b>Representative Block Diagram .....</b>	<b>4</b>
<b>3</b>	<b>Functional Description .....</b>	<b>5</b>
3.1	Introduction.....	5
3.2	Power Management .....	6
3.3	Improved Current Mode.....	7
3.3.1	PWM-OP .....	8
3.3.2	PWM-Comparator.....	8
3.4	Startup Phase .....	9
3.5	PWM Section.....	11
3.5.1	Oscillator .....	11
3.5.2	PWM-Latch FF1.....	12
3.5.3	Gate Driver.....	12
3.6	Current Limiting .....	13
3.6.1	Leading Edge Blanking.....	13
3.6.2	Propagation Delay Compensation (patented).....	14
3.7	Control Unit .....	15
3.7.1	Basic and Extendable Blanking Mode .....	15
3.7.2	Active Burst Mode (patented) .....	16
3.7.2.1	Entering Active Burst Mode .....	16
3.7.2.2	Working in Active Burst Mode.....	16
3.7.2.3	Leaving Active Burst Mode.....	17
3.7.3	Protection Modes .....	17
3.7.3.1	Auto Restart mode with extended blanking time.....	18
3.7.3.2	Auto Restart mode without extended blanking time .....	19
<b>4</b>	<b>Electrical Characteristics .....</b>	<b>20</b>
4.1	Absolute Maximum Ratings .....	20
4.2	Absolute Maximum Ratings .....	21
4.3	Characteristics.....	21
4.3.1	Supply Section .....	21
4.3.2	Internal Voltage Reference .....	22
4.3.3	PWM Section.....	22
4.3.4	Soft Start time .....	22
4.3.5	Control Unit.....	23
4.3.6	Current Limiting .....	24
4.3.7	CoolMOS™ Section .....	24
<b>5</b>	<b>CoolMOS™ Performance Characteristics.....</b>	<b>25</b>
<b>6</b>	<b>Input Power Curve .....</b>	<b>27</b>
<b>7</b>	<b>Outline Dimension .....</b>	<b>28</b>
<b>8</b>	<b>Marking .....</b>	<b>29</b>
<b>9</b>	<b>Schematic for recommended PCB layout .....</b>	<b>30</b>
	<b>Revision History .....</b>	<b>31</b>

Pin Configuration and Functionality

# 1 Pin Configuration and Functionality

**Table 1 Pin definitions and functions**

Pin	Symbol	Function
1, 9, 10	N.C	<b>Not Connected</b>
2	BA	<b>BA (extended Blanking &amp; Auto-restart enable)</b> The BA pin combines the functions of extendable blanking time for over load protection and the external auto-restart enable. The extendable blanking time function is to extend the built-in 20 ms blanking time by adding an external capacitor at BA pin to ground. The external auto-restart enable function is an external access to stop the gate switching and force the IC enter auto-restart mode. It is triggered by pulling down the BA pin to less than 0.33 V.
3	FB	<b>FB (Feedback)</b> The information about the regulation is provided by the FB Pin to the internal Protection Unit and to the internal PWM-Comparator to control the duty cycle. The FB-Signal is the only control signal in case of light load at the Active Burst Mode.
4	CS	<b>CS (Current Sense)</b> The Current Sense pin senses the voltage developed on the series resistor inserted in the source of the integrated CoolMOS™. If voltage in CS pin reaches the internal threshold of the Current Limit Comparator, the Driver output is immediately switched off. Furthermore the current information is provided for the PWM-Comparator to realize the Current Mode.
5, 6, 7, 8	Drain	<b>Drain (Drain of 650 V<sup>1</sup> integrated CoolMOS™)</b> Drain pins are connected to the Drain of integrated CoolMOS™.
11	VCC	<b>VCC (Power supply)</b> VCC pin is the positive supply of the IC. The operating range is between V <sub>VCCoff</sub> and V <sub>VCCOVp</sub> .
12	GND	<b>GND (Ground)</b> This is the common ground of the controller.

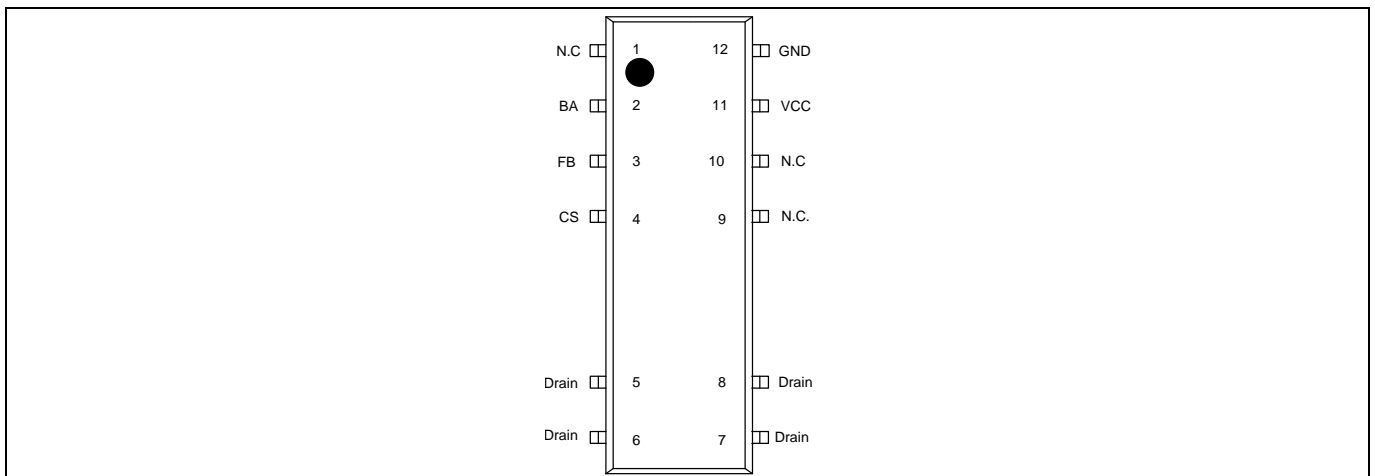
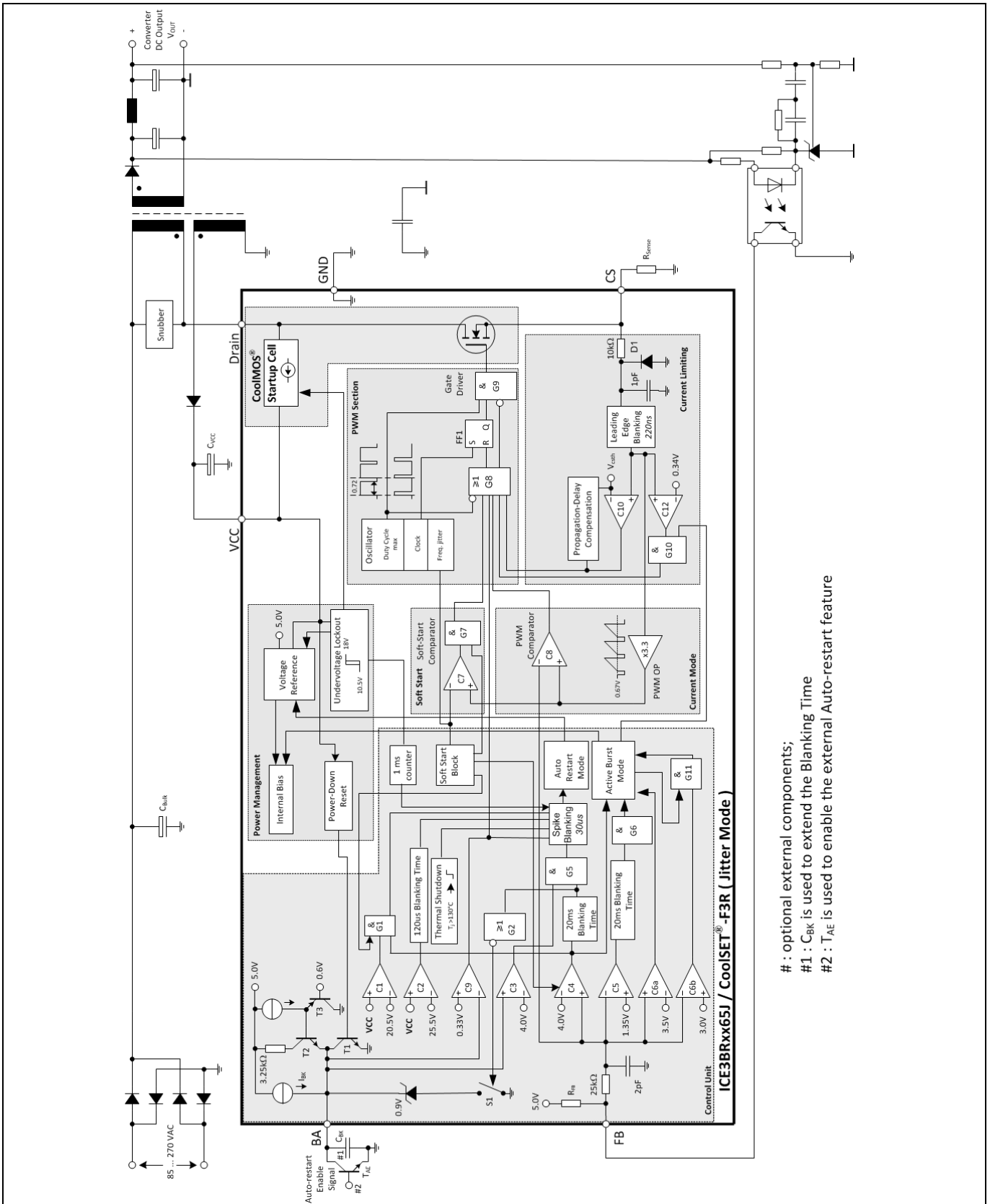

**Figure 2 Pin configuration PG-DSO-12(top view)**

<sup>1</sup>at T<sub>j</sub>=110°C

Representative Block Diagram

## 2 Representative Block Diagram



# : optional external components;  
 #1 : C<sub>BAK</sub> is used to extend the Blanking Time  
 #2 : T<sub>AE</sub> is used to enable the external Auto-restart feature

Figure 3 Representative Block Diagram

## Functional Description

### 3 Functional Description

All values which are used in the functional description are typical values. For calculating the worst cases the min/max values which can be found in section 4 Electrical Characteristics have to be considered.

#### 3.1 Introduction

ICE3RBR1765JG (ICE3RBRxx65JG series) is the new member of ICE3RBRxx65Jx in DSO-12 package. A high voltage Startup Cell is integrated into the IC which is switched off once the Undervoltage Lockout on-threshold of 18 V is exceeded. This Startup Cell is part of the integrated CoolMOS™. The external startup resistor is no longer necessary as this Startup Cell is connected to the Drain. Power losses are therefore reduced. This increases the efficiency under light load conditions drastically.

The particular features are the active burst mode, propagation delay compensation, modulated gate driving, auto-restart protection for Vcc overvoltage, over temperature, over load, open loop, built-in soft start, blanking window and frequency jitter. It provides the flexibility to increase the blanking window by simply addition of a capacitor in BA pin. In order to further increase the flexibility of the protection feature, an external auto-restart enable feature is added.

The intelligent Active Burst Mode can effectively obtain the lowest Standby Power at light load and no load conditions. After entering the burst mode, there is still a full control of the power conversion to the output through the optocoupler, that is used for the normal PWM control. The response on load jumps is optimized and the voltage ripple on Vout is minimized. The Vout is on well controlled in this mode.

The usually external connected RC-filter in the feedback line after the optocoupler is integrated in the IC to reduce the external part count.

Adopting the BiCMOS technology, it can increase the design flexibility as the Vcc voltage range is increased to 25 V.

It has a built-in 20 ms soft start function.

There are 2 modes of blanking time for high load jumps; the basic mode and the extendable mode. The blanking time for the basic mode is set at 20 ms while the extendable mode will increase the blanking time by adding an external capacitor at the BA pin in addition to the basic mode blanking time. During this blanking time window the system can give the maximum power to the loading.

In order to increase the robustness and safety of the system, the IC provides Auto Restart protection. The Auto Restart Mode reduces the average power conversion to a minimum level under unsafe operating conditions. This is necessary for a prolonged fault condition which could otherwise lead to a destruction of the SMPS over time. Once the malfunction is removed, normal operation is automatically retained after the next Start Up Phase. To make the protection more flexible, an external auto-restart enable pin is provided. When the pin is triggered, the switching pulse at gate will stop and the IC enters the auto-restart mode after the pre-defined spike blanking time.

The internal precise peak current control reduces the costs for the transformer and the secondary diode. The influence of the change in the input voltage on the maximum power limitation can be avoided together with the integrated Propagation Delay Compensation. Therefore the maximum power is nearly independent on the input voltage, which is required for wide range SMPS. Thus there is no need for the over-sizing of the SMPS, e.g. the transformer and the output diode.

Furthermore, it implements the frequency jitter mode to the switching clock such that the EMI noise will be effectively reduced.

Functional Description

3.2 Power Management

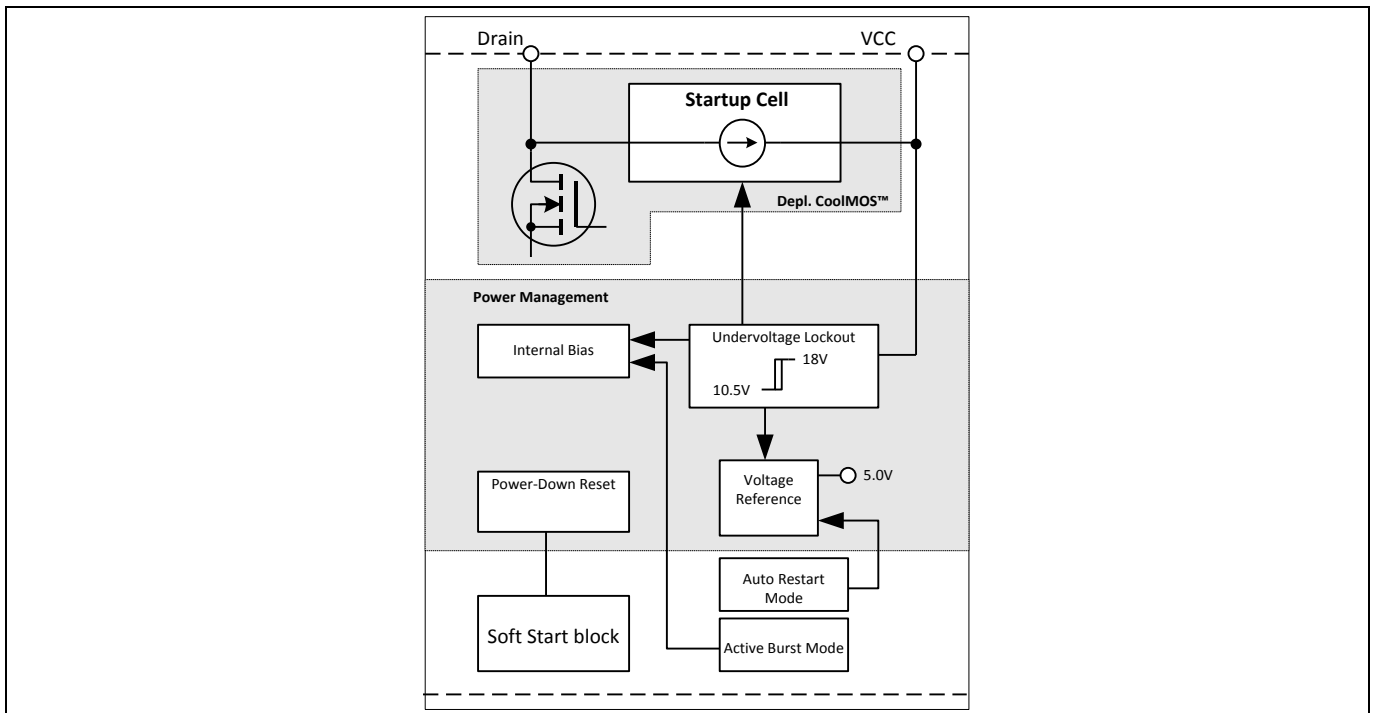

Figure 4 Power Management

The Undervoltage Lockout monitors the external supply voltage  $V_{VCC}$ . When the SMPS is plugged to the main line the internal Startup Cell is biased and starts to charge the external capacitor  $C_{VCC}$  which is connected to the VCC pin. This VCC charge current is controlled to 0.9 mA by the Startup Cell. When the  $V_{VCC}$  exceeds the on-threshold  $V_{VCCon}=18\text{ V}$  the bias circuit are switched on. Then the Startup Cell is switched off by the Undervoltage Lockout and therefore no power losses present due to the connection of the Startup Cell to the Drain voltage. To avoid uncontrolled ringing at switch-on, a hysteresis start up voltage is implemented. The switch-off of the controller can only take place when  $V_{VCC}$  falls below 10.5 V after normal operation was entered. The maximum current consumption before the controller is activated is about 150 mA.

When  $V_{VCC}$  falls below the off-threshold  $V_{VCCoff}=10.5\text{ V}$ , the bias circuit is switched off and the soft start counter is reset. Thus it is ensured that at every startup cycle the soft start starts at zero.

The internal bias circuit is switched off if Auto Restart Mode is entered. The current consumption is then reduced to 150mA.

Once the malfunction condition is removed, this block will then turn back on. The recovery from Auto Restart Mode does not require re-cycling the AC line.

When Active Burst Mode is entered, the internal Bias is switched off most of the time but the Voltage Reference is kept alive in order to reduce the current consumption below 450  $\mu\text{A}$ .

Functional Description

3.3 Improved Current Mode

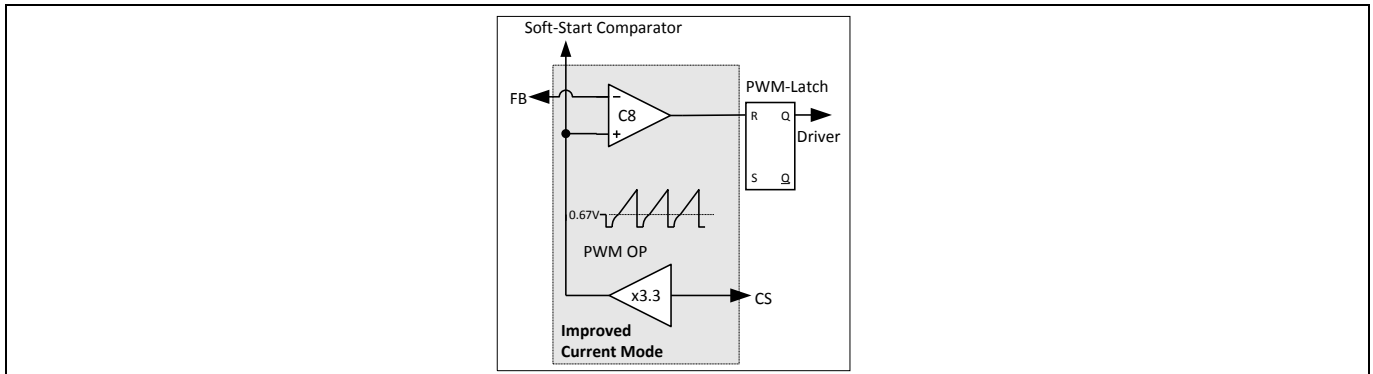

Figure 5 Current Mode

Current Mode means the duty cycle is controlled by the slope of the primary current. This is done by comparing the FB signal with the amplified current sense signal.

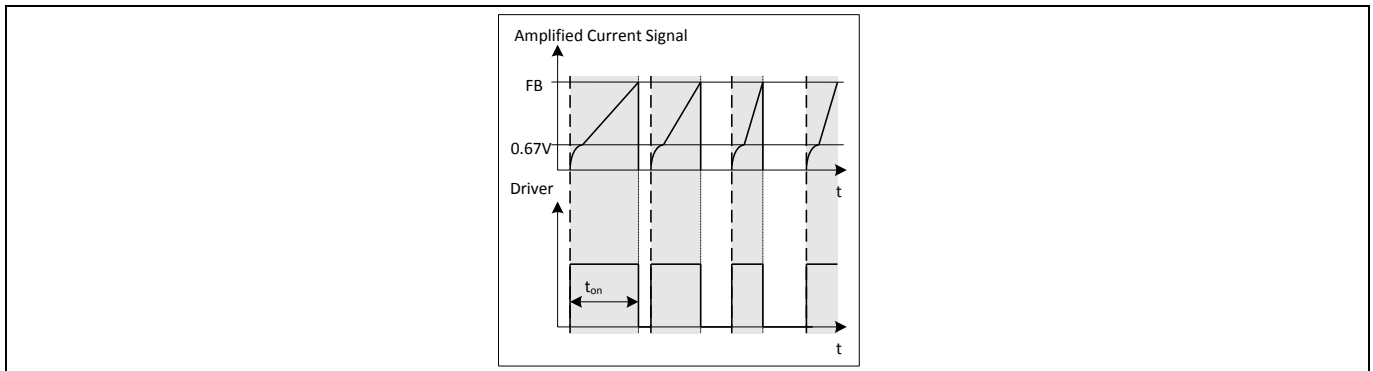

Figure 6 Pulse Width Modulation

In case the amplified current sense signal exceeds the FB signal the on-time  $T_{on}$  of the driver is finished by resetting the PWM-Latch (Figure 6).

The primary current is sensed by the external series resistor  $R_{Sense}$  inserted in the source of the integrated CoolMOS™. By means of Current Mode regulation, the secondary output voltage is insensitive to the line variations. The current waveform slope will change with the line variation, which controls the duty cycle.

The external  $R_{Sense}$  allows an individual adjustment of the maximum source current of the integrated CoolMOS™.

To improve the Current Mode during light load conditions the amplified current ramp of the PWM-OP is superimposed on a voltage ramp, which is built by the switch T2, the voltage source V1 and a resistor R1 (Figure 7). Every time the oscillator shuts down for maximum duty cycle limitation the switch T2 is closed by  $V_{Osc}$ . When the oscillator triggers the Gate Driver, T2 is opened so that the voltage ramp can start.

In case of light load the amplified current ramp is too small to ensure a stable regulation. In that case the Voltage Ramp is a well defined signal for the comparison with the FB-signal. The duty cycle is then controlled by the slope of the Voltage Ramp.

By means of the time delay circuit which is triggered by the inverted  $V_{Osc}$  signal, the Gate Driver is switched-off until it reaches approximately 156 ns delay time (Figure 8). It allows the duty cycle to be reduced continuously till 0% by decreasing  $V_{FB}$  below that threshold.

Functional Description

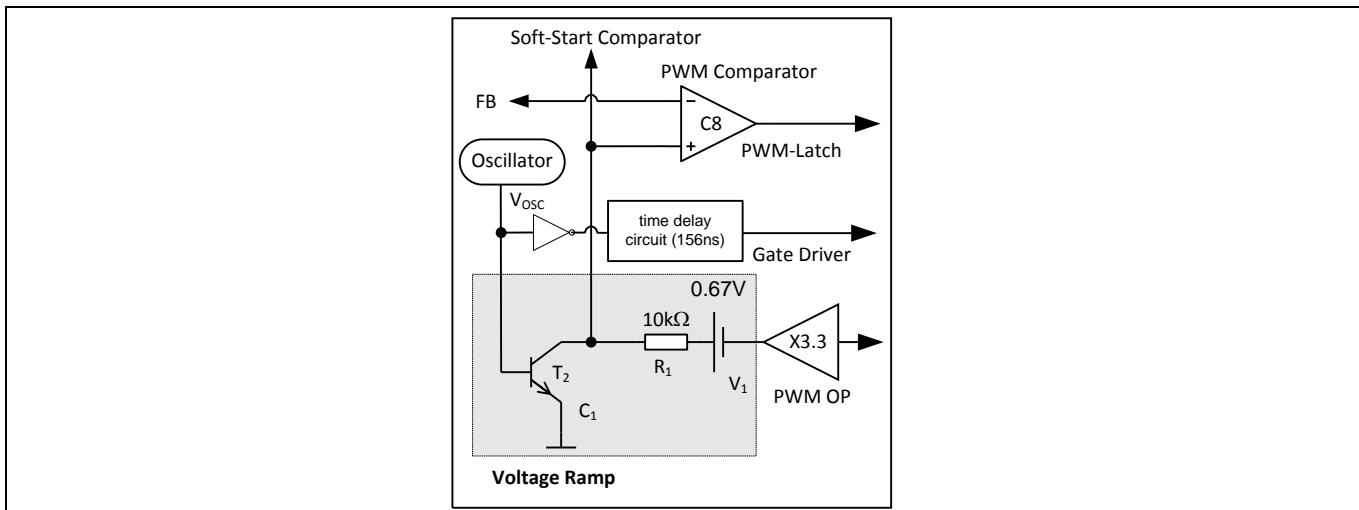

Figure 7 Improved Current Mode

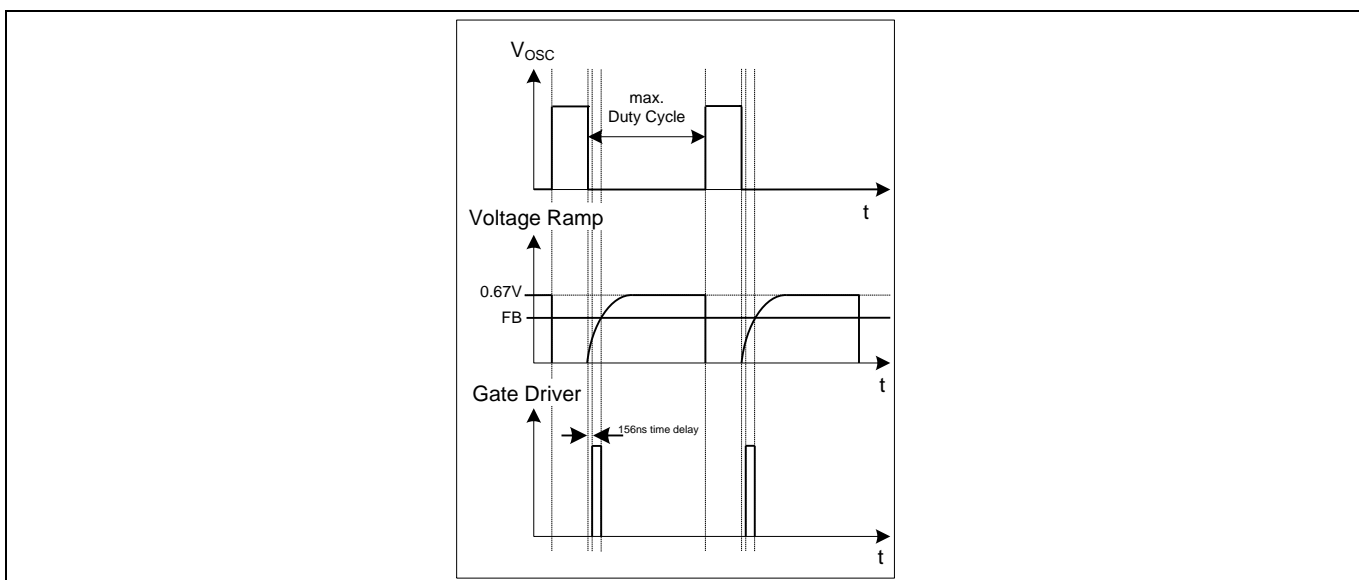

Figure 8 Light Load Conditions

### 3.3.1 PWM-OP

The input of the PWM-OP is applied over the internal leading edge blanking to the external sense resistor  $R_{Sense}$  connected to pin CS.  $R_{Sense}$  converts the source current into a sense voltage. The sense voltage is amplified with a gain of 3.3 by PWM OP. The output of the PWM-OP is connected to the voltage source  $V_1$ . The voltage ramp with the superimposed amplified current signal is fed into the positive inputs of the PWM-Comparator C8 and the Soft-Start-Comparator (Figure 7).

### 3.3.2 PWM-Comparator

The PWM-Comparator compares the sensed current signal of the integrated CoolMOS™ with the feedback signal  $V_{FB}$  (Figure 9).  $V_{FB}$  is created by an external optocoupler or external transistor in combination with the internal pull-up resistor  $R_{FB}$  and provides the load information of the feedback circuitry. When the amplified current signal of the integrated CoolMOS™ exceeds the signal  $V_{FB}$ , the PWM-Comparator switches off the Gate Driver.



Functional Description

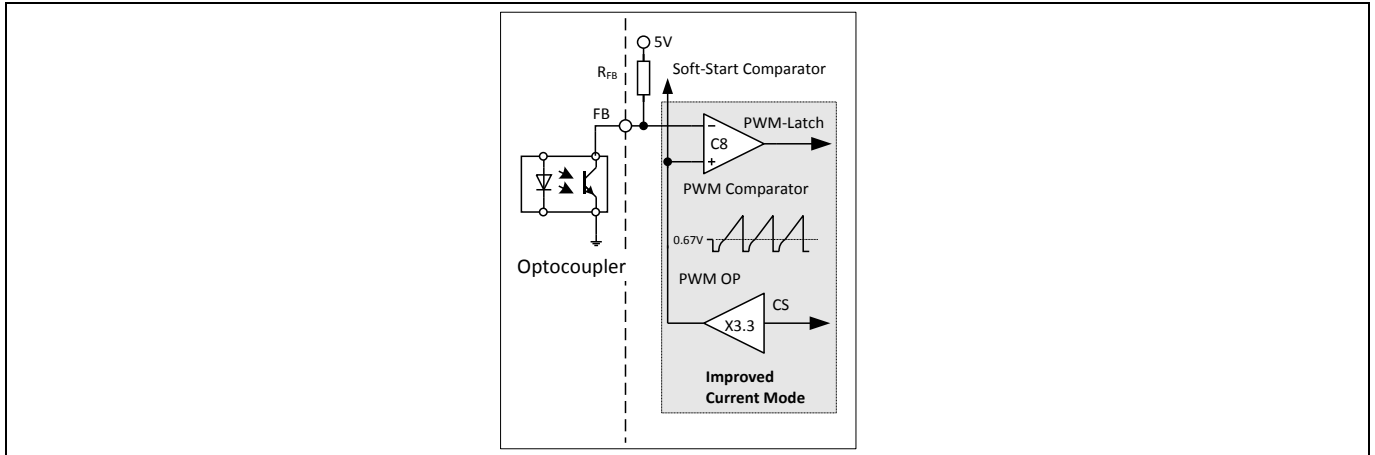

Figure 9 PWM Controlling

3.4 Startup Phase

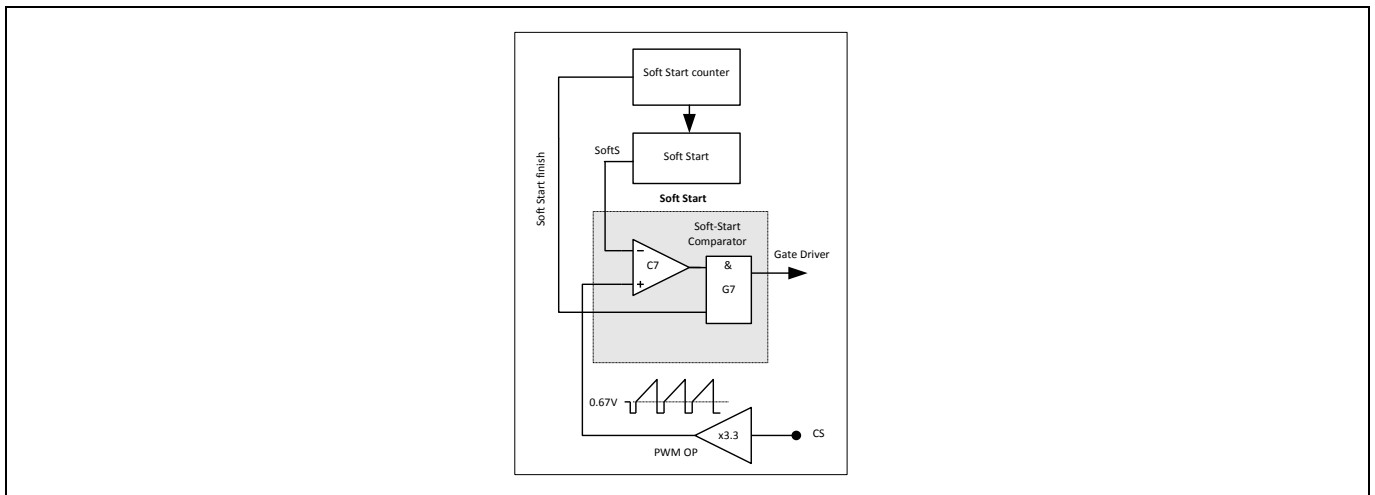

Figure 10 Soft Start

In the Startup Phase, the IC provides a Soft Start period to control the primary current by means of a duty cycle limitation. The Soft Start function is a built-in function and it is controlled by an internal counter.

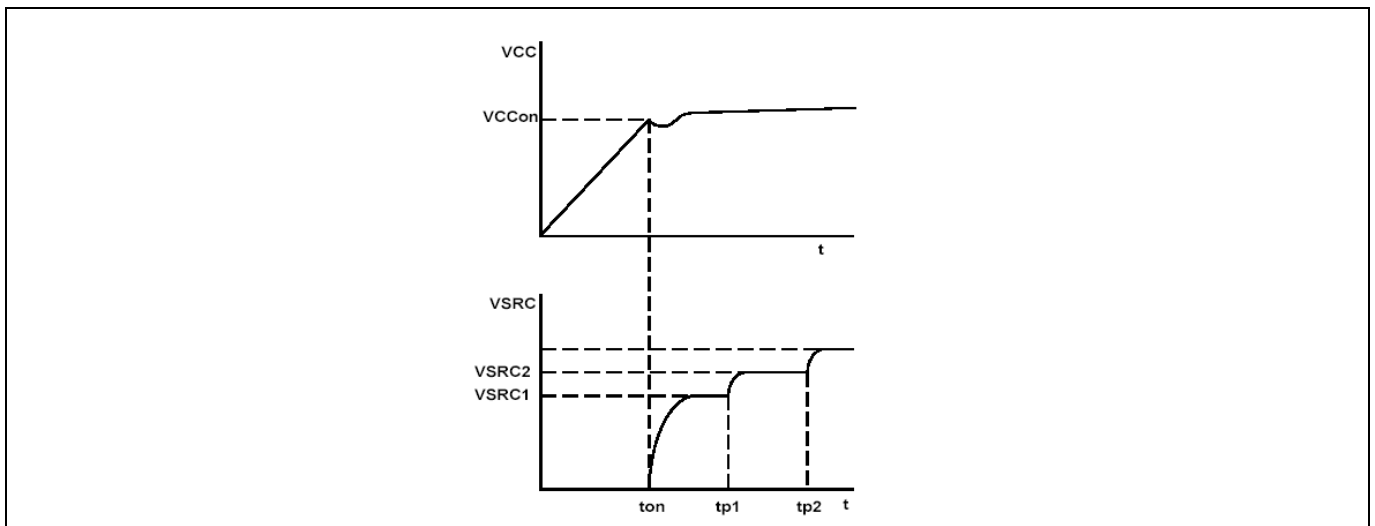
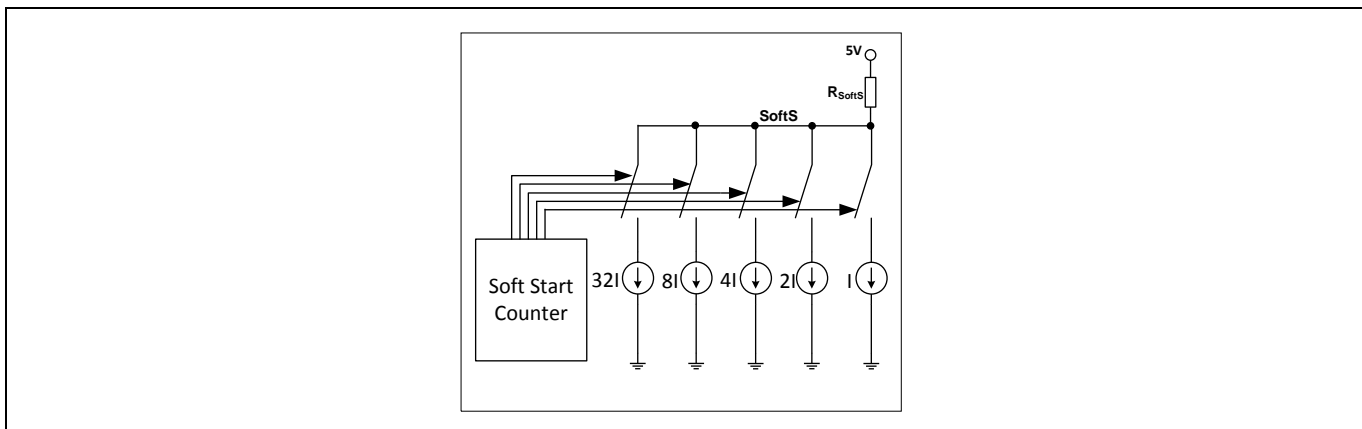

Figure 11 Soft Start Phase

**Functional Description**

When the  $V_{VCC}$  exceeds the on-threshold voltage, the IC starts the Soft Start mode (Figure 11).

The function is realized by an internal Soft Start resistor, a current sink and a counter. And the amplitude of the current sink is controlled by the counter (Figure 12).



**Figure 12 Soft Start Circuit**

After the IC is switched on, the  $V_{SOFTS}$  voltage is controlled such that the voltage is increased step-wisely (32 steps) with the increase of the counts. The Soft Start counter would send a signal to the current sink control in every  $600 \mu s$  such that the current sink decrease gradually and the duty ratio of the gate drive increases gradually. The Soft Start will be finished in 20 ms ( $T_{Soft-Start}$ ) after the IC is switched on. At the end of the Soft Start period, the current sink is switched off.

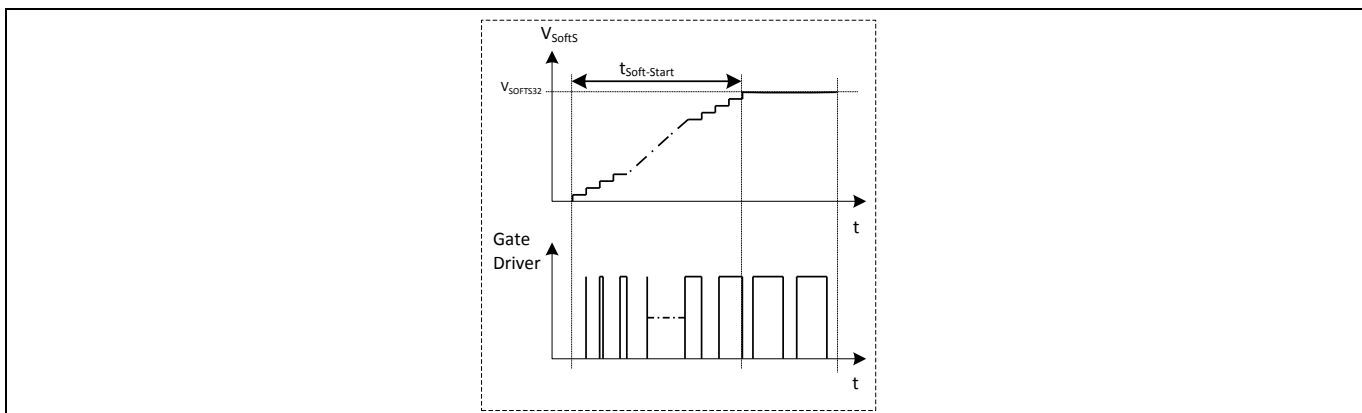

**Figure 13 Gate drive signal under Soft-Start Phase**

Within the soft start period, the duty cycle is increasing from zero to maximum gradually (Figure 13).

In addition to Start-Up, Soft-Start is also activated at each restart attempt during Auto Restart

Functional Description

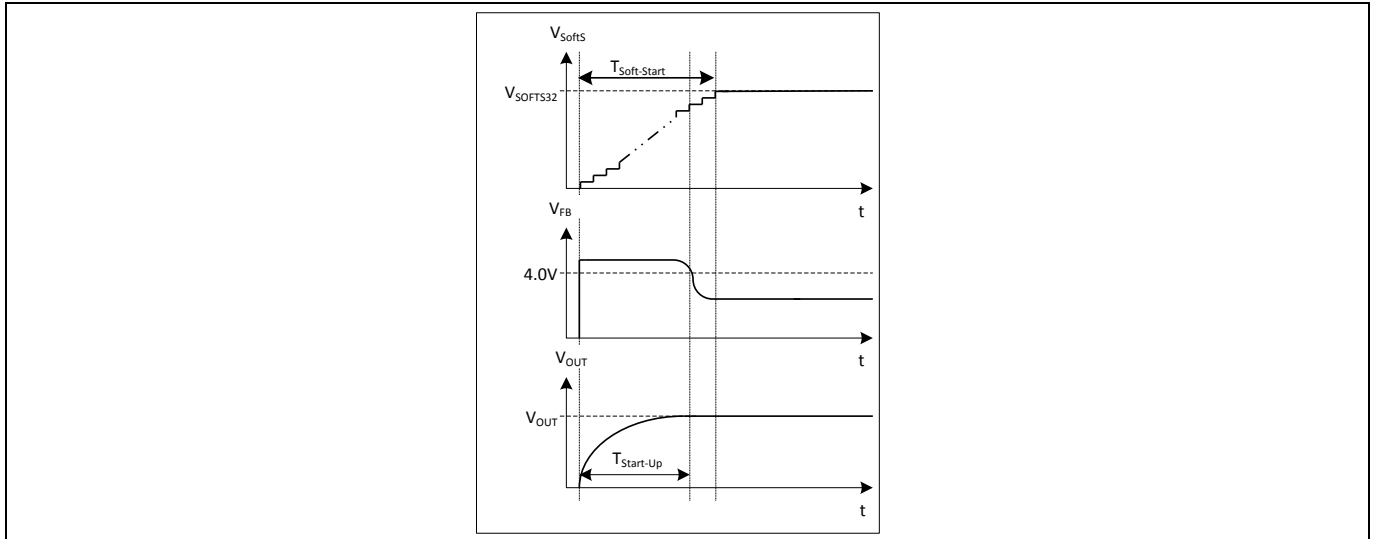

Figure 14 Start Up Phase

The Start-Up time  $T_{Start-Up}$  before the converter output voltage  $V_{OUT}$  is settled, must be shorter than the Soft-Start Phase  $T_{Soft-Start}$  (Figure 14).

By means of Soft-Start there is an effective minimization of current and voltage stresses on the integrated CoolMOS™, the clamp circuit and the output overshoot and it helps to prevent saturation of the transformer during Start-Up.

### 3.5 PWM Section

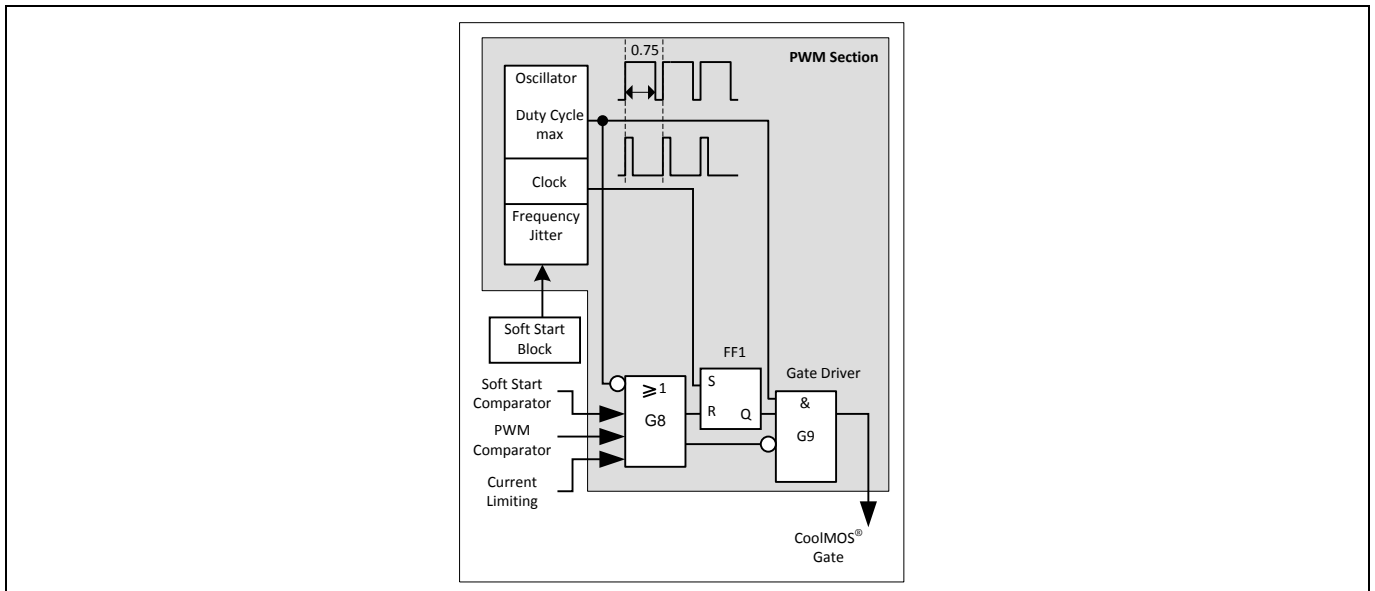

Figure 15 PWM Section Block

#### 3.5.1 Oscillator

The oscillator generates a fixed frequency of 65 kHz with frequency jittering of  $\pm 4\%$  (which is  $\pm 2.6$  kHz) at a jittering period of 4 ms.

A capacitor, a current source and current sink which determine the frequency are integrated. In order to achieve a very accurate switching frequency, the charging and discharging current of the implemented

**Functional Description**

oscillator capacitor are internally trimmed. The ratio of controlled charge to discharge current is adjusted to reach a maximum duty cycle limitation of  $D_{max}=0.75$ .

Once the Soft Start period is over and when the IC goes into normal operating mode, the switching frequency of the clock is varied by the control signal from the Soft Start block. Then the switching frequency is varied in range of  $65\text{ kHz} \pm 2.6\text{ kHz}$  at period of 4 ms.

**3.5.2 PWM-Latch FF1**

The output of the oscillator block provides continuous pulse to the PWM-Latch which turns on/off the integrated CoolMOS™. After the PWM-Latch is set, it is reset by the PWM comparator, the Soft Start comparator or the Current -Limit comparator. When it is in reset mode, the output of the driver is shut down immediately.

**3.5.3 Gate Driver**

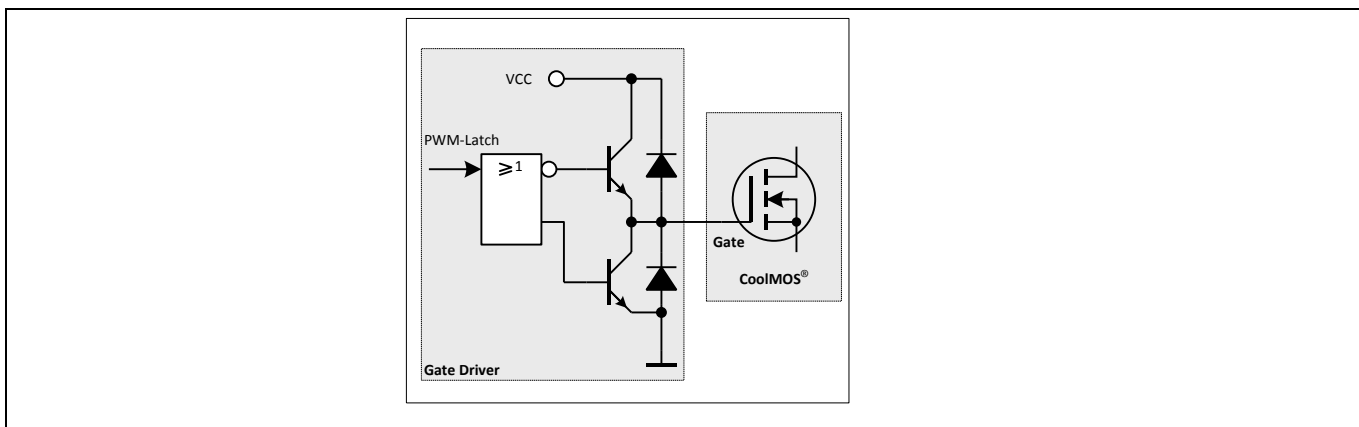

**Figure 16 Gate Driver**

The driver-stage is optimized to minimize EMI and to provide high circuit efficiency. The switch on speed is slowed down before it reaches the integrated CoolMOS™ turn on threshold. That is a slope control of the rising edge at the output of the driver (Figure 17).

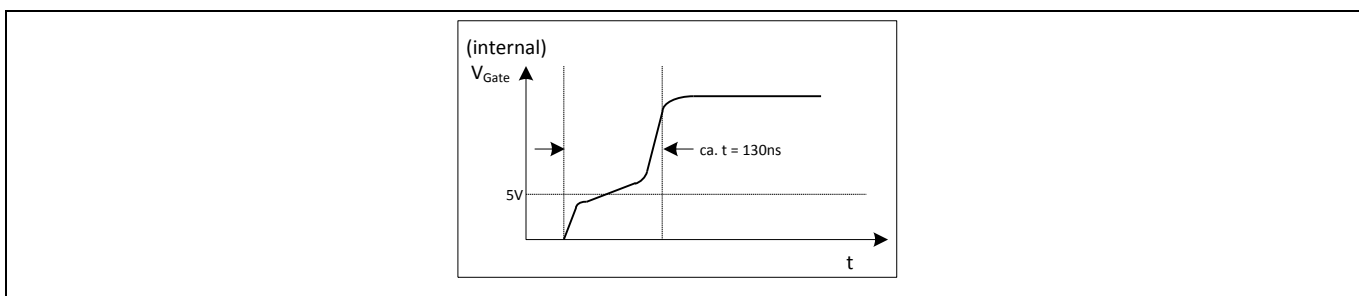

**Figure 17 Gate Rising Slope**

Functional Description

3.6 Current Limiting

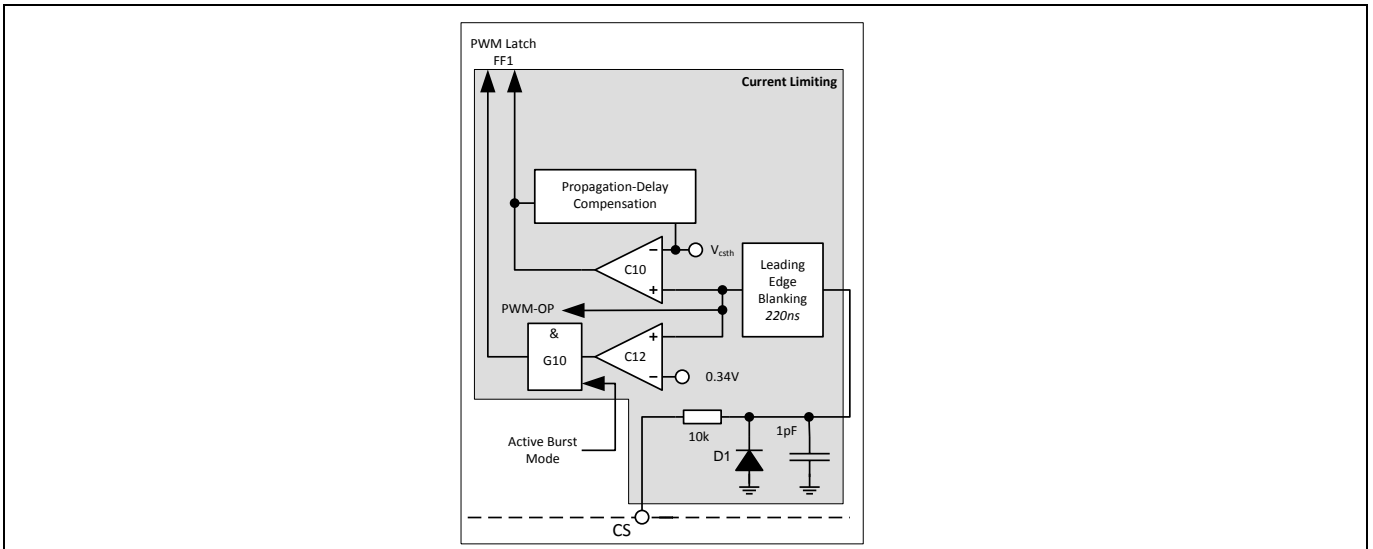

Figure 18 Current Limiting Block

There is a cycle by cycle peak current limiting operation realized by the Current-Limit comparator C10. The source current of the integrated CoolMOS™ is sensed via an external sense resistor  $R_{Sense}$ . By means of  $R_{Sense}$  the source current is transformed to a sense voltage  $V_{Sense}$  which is fed into the CS pin. If the voltage  $V_{Sense}$  exceeds the internal threshold voltage  $V_{csth}$ , the comparator C10 immediately turns off the gate drive by resetting the PWM Latch FF1.

A Propagation Delay Compensation is added to support the immediate shut down of the integrated CoolMOS™ with very short propagation delay. Thus the influence of the AC input voltage on the maximum output power can be reduced to minimal.

In order to prevent the current limit from distortions caused by leading edge spikes, a Leading Edge Blanking is integrated in the current sense path for the comparators C10, C12 and the PWM-OP.

The output of comparator C12 is activated by the Gate G10 if Active Burst Mode is entered. When it is activated, the current limiting is reduced to 0.34 V. This voltage level determines the maximum power level in Active Burst Mode.

3.6.1 Leading Edge Blanking

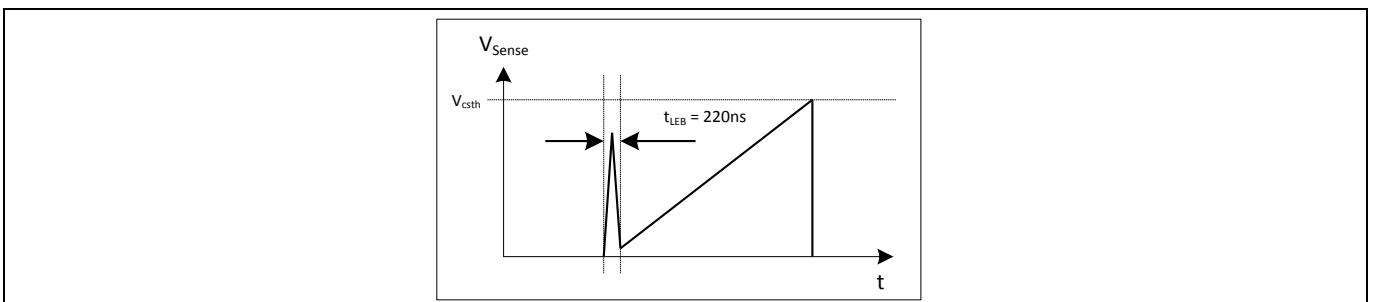

Figure 19 Leading Edge Blanking

Whenever the integrated CoolMOS™ is switched on, a leading edge spike is generated due to the primary-side capacitances and reverse recovery time of the secondary-side rectifier. This spike can cause the gate drive to switch off unintentionally. In order to avoid a premature termination of the switching pulse, this spike is blanked out with a time constant of  $t_{LEB} = 220$  ns.

Functional Description

3.6.2 Propagation Delay Compensation (patented)

In case of over-current detection, there is always propagation delay to switch off the integrated CoolMOS™. An overshoot of the peak current  $I_{peak}$  is induced to the delay, which depends on the ratio of  $dI/dt$  of the peak current (Figure 20).

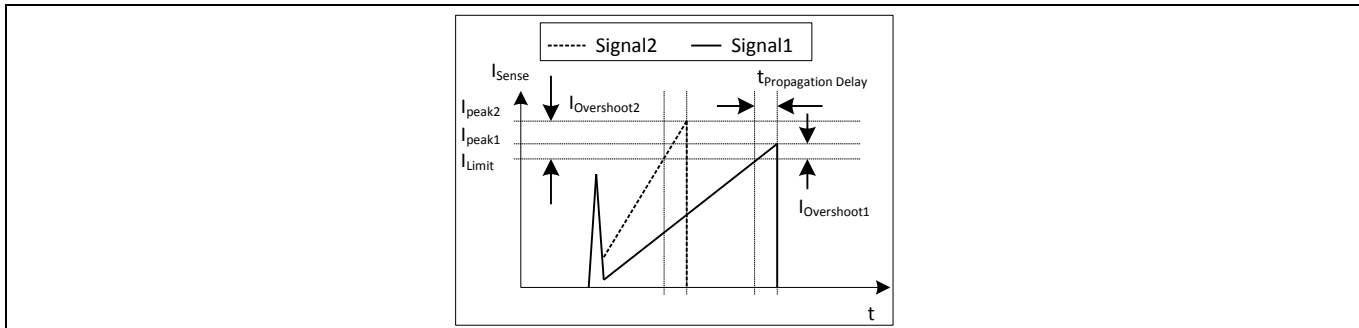

Figure 20 Current Limiting

The overshoot of Signal2 is larger than of Signal1 due to the steeper rising waveform. This change in the slope depends on the AC input voltage. Propagation Delay Compensation is integrated to reduce the overshoot due to  $dI/dt$  of the rising primary current. Thus the propagation delay time between exceeding the current sense threshold  $V_{csth}$  and the switching off of the integrated CoolMOS™ is compensated over temperature within a wide range. Current Limiting is then very accurate.

For example,  $I_{peak} = 0.5\text{ A}$  with  $R_{Sense} = 2$ . The current sense threshold is set to a static voltage level  $V_{csth} = 1\text{ V}$  without Propagation Delay Compensation. A current ramp of  $dI/dt = 0.4\text{ A}/\mu\text{s}$ , or  $dV_{Sense}/dt = 0.8\text{ V}/\mu\text{s}$ , and a propagation delay time of  $t_{Propagation\ Delay} = 180\text{ ns}$  leads to an  $I_{peak}$  overshoot of 14.4%. With the propagation delay compensation, the overshoot is only around 2% (Figure 21).

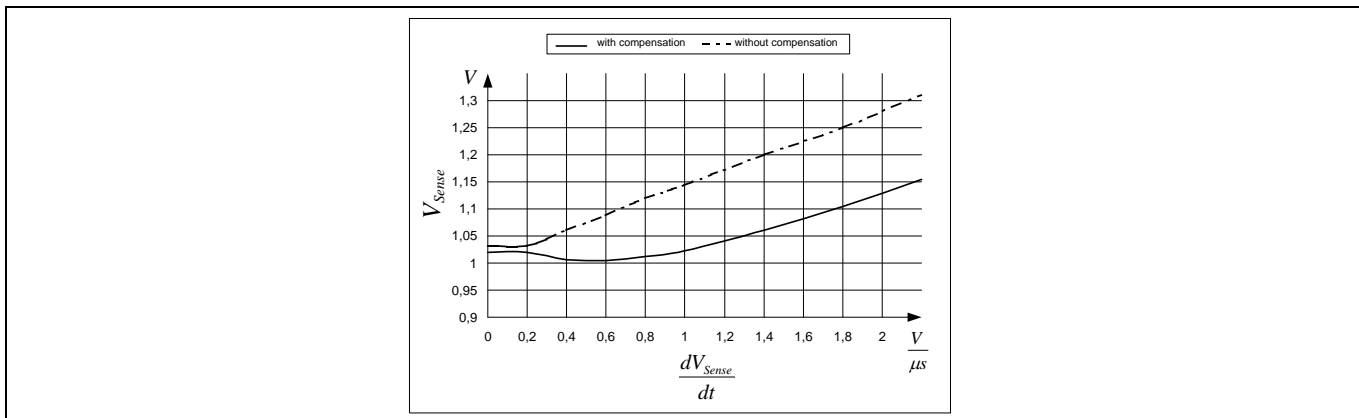

Figure 21 Overcurrent Shutdown

The Propagation Delay Compensation is realized by means of a dynamic threshold voltage  $V_{csth}$  (Figure 22). In case of a steeper slope the switch off of the driver is earlier to compensate the delay.

Functional Description

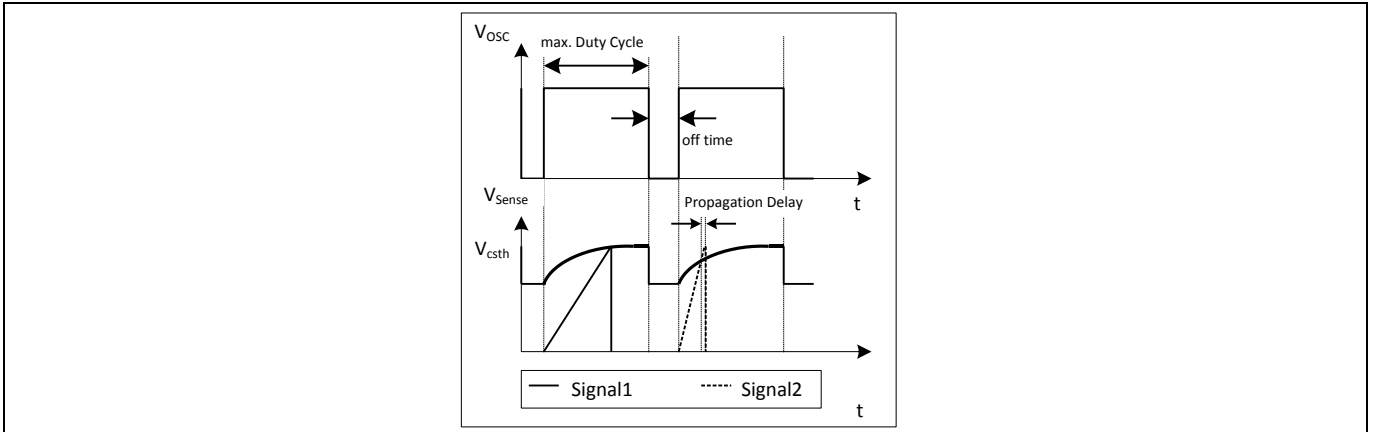

Figure 22 Dynamic Voltage Threshold  $V_{csth}$

### 3.7 Control Unit

The Control Unit contains the functions for Active Burst Mode and Auto Restart Mode. The Active Burst Mode and the Auto Restart Mode both have 20 ms internal Blanking Time. For the Auto Restart Mode, a further extendable Blanking Time is achieved by adding external capacitor at BA pin. By means of this Blanking Time, the IC avoids entering into these two modes accidentally. Furthermore that buffer time for the overload detection is very useful for the application that works in low current but requires a short duration of high current occasionally.

#### 3.7.1 Basic and Extendable Blanking Mode

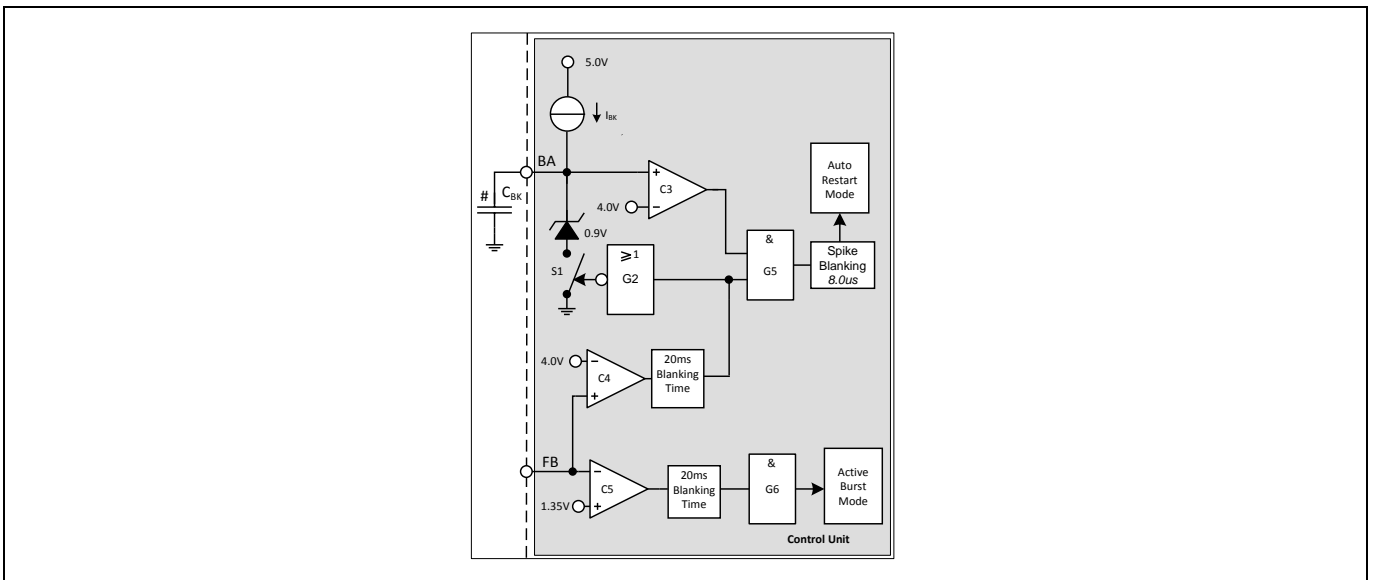

Figure 23 Basic and Extendable Blanking Mode

There are 2 kinds of Blanking mode; basic mode and the extendable mode. The basic mode is just an internal set 20 ms blanking time while the extendable mode has an extra blanking time by connecting an external capacitor to the BA pin in addition to the pre-set 20 ms blanking time. For the extendable mode, the gate G5 is blocked even though the 20 ms blanking time is reached if an external capacitor  $C_{BK}$  is added to BA pin. While the 20ms blanking time is passed, the switch S1 is opened by G2. Then the 0.9 V clamped voltage at BA pin is charged to 4.0 V through the internal  $I_{BK}$  constant current. G5 is enabled by comparator C3. After the 30  $\mu$ s spike blanking time, the Auto Restart Mode is activated.

For example, if  $C_{BK} = 0.22 \mu F$ ,  $I_{BK} = 13 \mu A$

**Functional Description**

$$\text{Blanking time} = 20 \text{ ms} + C_{BK} \times (4.0 - 0.9) / I_{BK} = 72 \text{ ms}$$

In order to make the startup properly, the maximum  $C_{BK}$  capacitor is restricted to less than 0.65  $\mu\text{F}$ .

The Active Burst Mode has basic blanking mode only while the Auto Restart Mode has both the basic and the extendable blanking mode.

**3.7.2 Active Burst Mode (patented)**

The IC enters Active Burst Mode under low load conditions. With the Active Burst Mode, the efficiency increases significantly at light load conditions while still maintaining a low ripple on  $V_{OUT}$  and a fast response on load jumps. During Active Burst Mode, the IC is controlled by the FB signal. Since the IC is always active, it can be a very fast response to the quick change at the FB signal. The Start up Cell is kept OFF in order to minimize the power loss. The Active Burst Mode is located in the Control Unit. Figure 24 shows the related components.

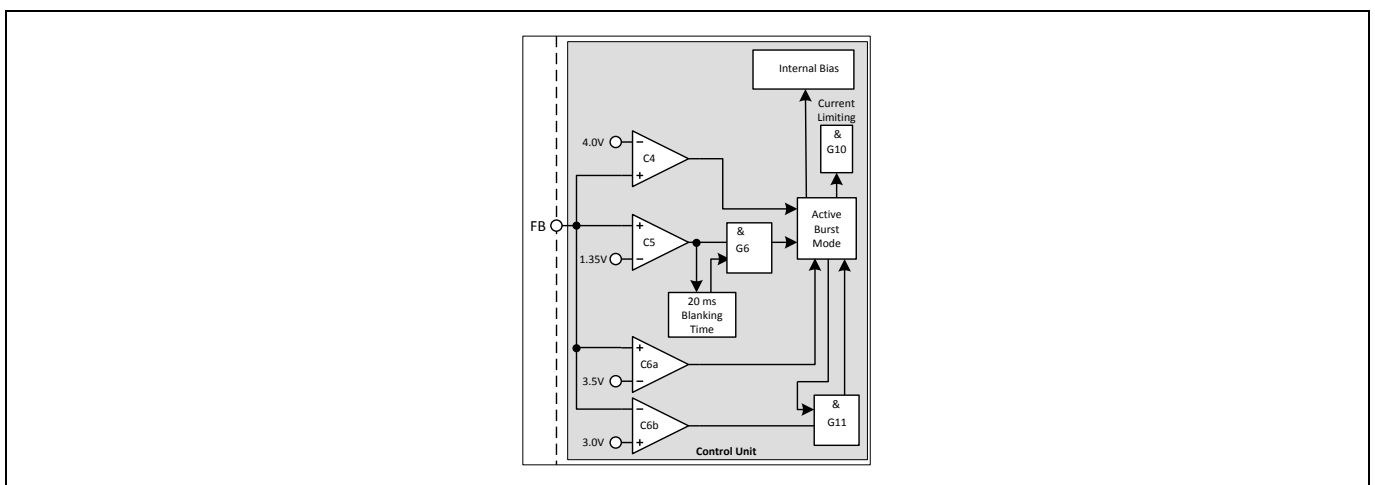

**Figure 24 Active Burst Mode**

**3.7.2.1 Entering Active Burst Mode**

The FB signal is kept monitoring by the comparator C5. During normal operation, the internal blanking time counter is reset to 0. Once the FB signal falls below 1.35 V, it starts to count. When the counter reach 20 ms and FB signal is still below 1.35 V, the system enters the Active Burst Mode. This time window prevents a sudden entering into the Active Burst Mode due to large load jumps.

After entering Active Burst Mode, a burst flag is set and the internal bias is switched off in order to reduce the current consumption of the IC to approximately 450  $\mu\text{A}$ .

It needs the application to enforce the VCC voltage above the Undervoltage Lockout level of 10.5 V such that the Startup Cell will not be switched on accidentally. Or otherwise the power loss will increase drastically. The minimum VCC level during Active Burst Mode depends on the load condition and the application. The lowest VCC level is reached at no load condition.

**3.7.2.2 Working in Active Burst Mode**

After entering the Active Burst Mode, the FB voltage rises as  $V_{OUT}$  starts to decrease, which is due to the inactive PWM section. The comparator C6a monitors the FB signal. If the voltage level is larger than 3.5 V, the internal circuit will be activated; the Internal Bias circuit resumes and starts to provide switching pulse. In Active Burst Mode the gate G10 is released and the current limit is reduced to 0.34 V, which can reduce the conduction loss and the audible noise. If the load at  $V_{OUT}$  is still kept unchanged, the FB signal will drop to 3.0 V. At this level the C6b deactivates the internal circuit again by switching off the internal Bias. The gate G11 is active again as the



**Functional Description**

burst flag is set after entering Active Burst Mode. In Active Burst Mode, the FB voltage is changing like a saw tooth between 3.0 V and 3.5 V (Figure 25).

**3.7.2.3 Leaving Active Burst Mode**

The FB voltage will increase immediately if there is a high load jump. This is observed by the comparator C4. Since the current limit is app. 34% during Active Burst Mode, it needs a certain load jump to rise the FB signal to exceed 4.0 V. At that time the comparator C4 resets the Active Burst Mode control which in turn blocks the comparator C12 by the gate G10. The maximum current can then be resumed to stabilize the  $V_{OUT}$ .

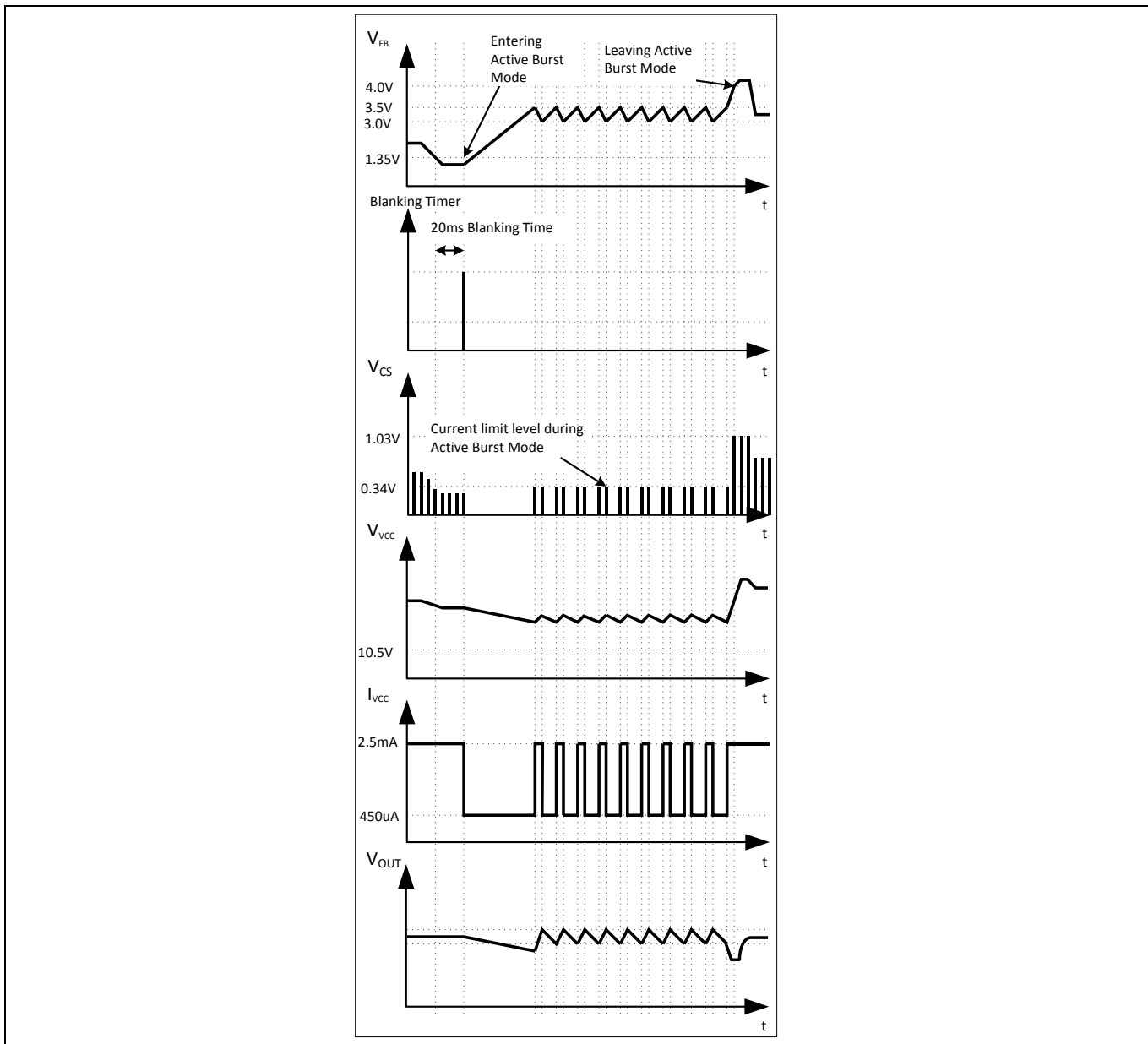

**Figure 25 Signals in Active Burst Mode**

**3.7.3 Protection Modes**

The IC provides Auto Restart Mode as the protection feature. Auto Restart mode can prevent the SMPS from destructive states. The following table shows the relationship between possible system failures and the corresponding protection modes.

**Functional Description**

Before entering the Auto Restart protection mode, some of the protections can have extended blanking time to delay the protection and some needs to fast react and will go straight to the protection. Overload and open loop protection are the one can have extended blanking time while VCC Overvoltage, Over temperature, VCC Undervoltage, short opto-coupler and external auto restart enable will go to protection right away.

**Table 2 Protection functions**

Protection function	Failure condition	Protection Mode
VCC Overvoltage	1. $V_{VCC} > 20.5\text{ V}$ & $FB > 4\text{ V}$ & during soft start period & last for $30\ \mu\text{s}$ 2. $V_{VCC} > 25.5\text{ V}$ & last for $(120+30)\ \mu\text{s}$ (inactivated during burst mode)	Auto Restart
Overtemperature (controller junction)	$T_j > 140\text{ }^\circ\text{C}$ & last of $30\ \mu\text{s}$	Auto Restart
Overload/Open Loop	$V_{FB} > 4\text{ V}$ & last for $20\text{ms}$ & $V_{BA} > 4.0\text{ V}$ & last for $30\ \mu\text{s}$ (extended blanking time counted from charging $V_{BA}$ from $0.9\text{ V}$ to $4.0\text{ V}$ )	Auto Restart
VCC Undervoltage/ Short Optocoupler	$V_{VCC} < 10.5\text{ V}$ & last for $10\text{ ms} + 30\ \mu\text{s}$	Auto Restart
Auto restart enable	$V_{BA} < 0.33\text{ V}$ & last for $30\ \mu\text{s}$	Auto Restart

After the system enters the Auto-restart mode, the IC will be off. Since there is no more switching, the VCC voltage will drop. When it hits the Vcc turn off threshold, the start up cell will turn on and the Vcc is charged by the startup cell current to VCC turn on threshold. The IC is on and the startup cell will turn off. At this stage, it will enter the startup phase (soft start) with switching cycles. After the Start Up Phase, the fault condition is checked. If the fault condition persists, the IC will go to auto restart mode again. If, otherwise, the fault is removed, normal operation is resumed.

**3.7.3.1 Auto Restart mode with extended blanking time**

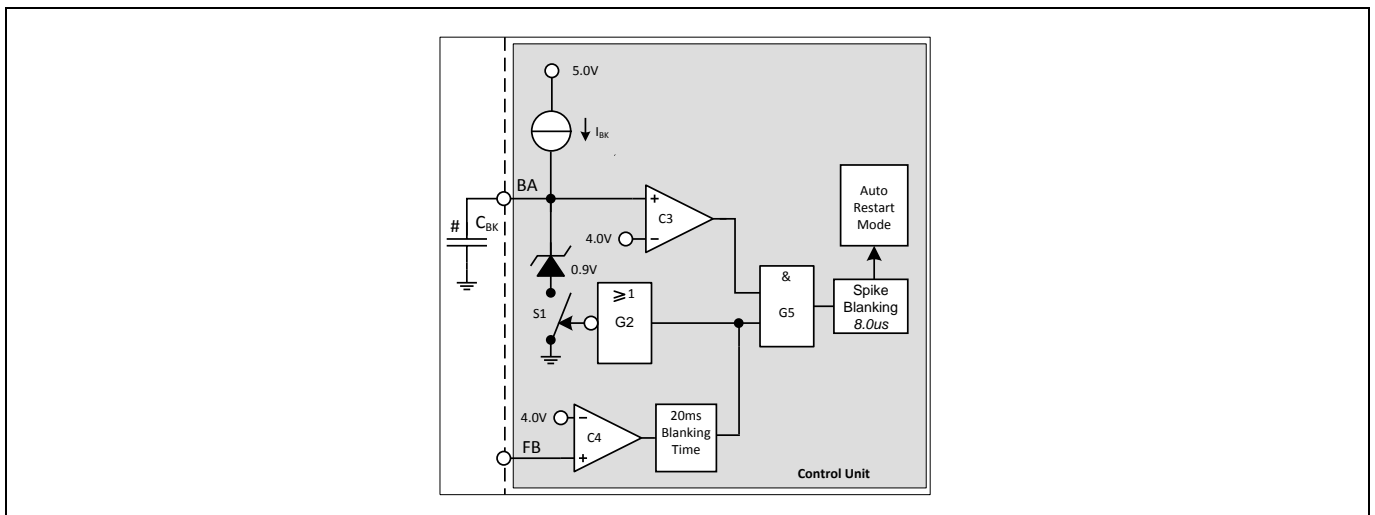

**Figure 26 Auto Restart Mode**

In case of Overload or Open Loop, the FB exceeds 4.0 V which will be observed by comparator C4. Then the internal blanking counter starts to count. When it reaches 20 ms, the switch S1 is released. Then the clamped voltage 0.9 V at  $V_{BA}$  can increase. When there is no external capacitor  $C_{BK}$  connected, the  $V_{BA}$  will reach 4.0 V immediately. When both the input signals at AND gate G5 is positive, the Auto Restart Mode will be activated after the extra spike blanking time of  $30\ \mu\text{s}$  is elapsed. However, when an extra blanking time is needed, it can be

**Functional Description**

achieved by adding an external capacitor,  $C_{BK}$ . A constant current source of  $I_{BK}$  will start to charge the capacitor  $C_{BK}$  from 0.9 V to 4.0 V after the switch S1 is released. The charging time from 0.9 V to 4.0 V are the extendable blanking time. If  $C_{BK}$  is 0.22  $\mu$ F and  $I_{BK}$  is 13  $\mu$ A, the extendable blanking time is around 52 ms and the total blanking time is 72 ms. In combining the FB and blanking time, there is a blanking window generated which prevents the system to enter Auto Restart Mode due to large load jumps.

**3.7.3.2 Auto Restart mode without extended blanking time**

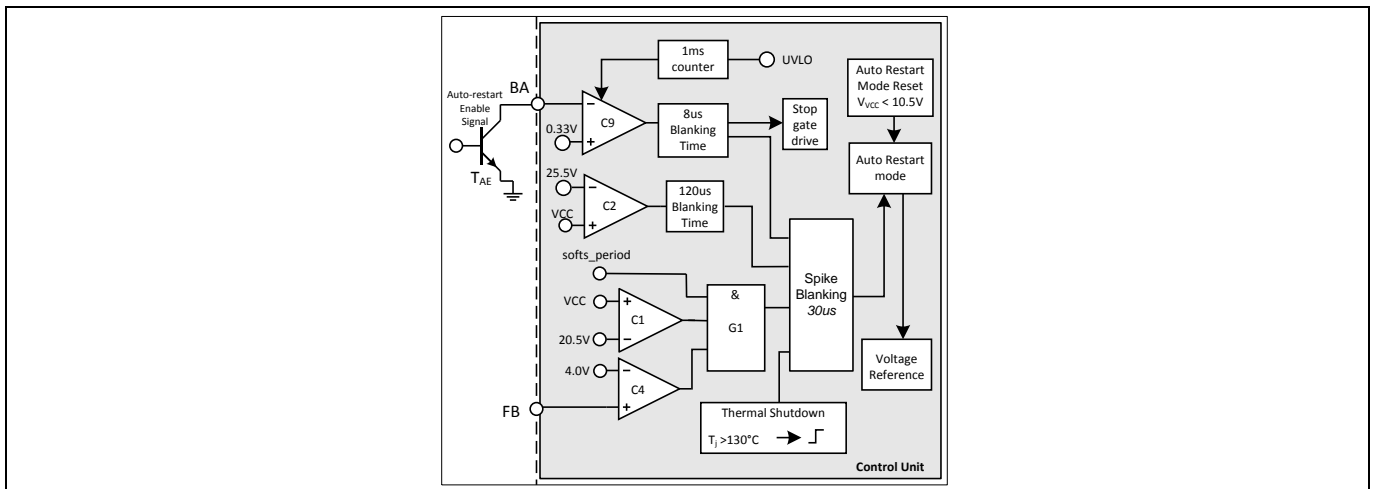

**Figure 27 Over load, open loop protection**

There are 2 modes of VCC overvoltage protection; one is during soft start and the other is at all conditions. The first one is  $V_{VCC}$  voltage is  $> 20.5$  V and FB is  $> 4.0$  V and during soft start period and the IC enters Auto Restart Mode. The VCC voltage is observed by comparator C1 and C4. The fault conditions are to detect the abnormal operating during start up such as open loop during light load start up, etc. The logic can eliminate the possible of entering Auto Restart mode if there is a small voltage overshoots of  $V_{VCC}$  during normal operating. The 2nd one is  $V_{VCC} > 25.5$  V and last for 120  $\mu$ s and the IC enters Auto Restart Mode. This 25.5 V  $V_{VCC OVP}$  protection is inactivated during burst mode.

The Thermal Shutdown block monitors the junction temperature of the IC. After detecting a junction temperature higher than 130 °C, the Auto Restart Mode is entered.

In case the pre-defined auto-restart features are not sufficient, there is a customer defined external Auto-restart Enable feature. This function can be triggered by pulling down the BA pin to  $< 0.33$  V. It can simply add a trigger signal to the base of the externally added transistor,  $T_{AE}$  at the BA pin. When the function is enabled, the gate drive switching will be stopped and then the IC will enter auto-restart mode if the signal persists. To ensure this auto-restart function will not be mis-triggered during start up, a 1 ms delay time is implemented to blank the unstable signal.

VCC undervoltage is the VCC voltage drop below  $V_{cc}$  turn off threshold. Then the IC will turn off and the start up cell will turn on automatically. And this leads to Auto Restart Mode.

Short Optocoupler also leads to VCC undervoltage as there is no self supply after activating the internal reference and bias.

Electrical Characteristics

## 4 Electrical Characteristics

Note: All voltages are measured with respect to ground (Pin 12). The voltage levels are valid if other ratings are not violated.

### 4.1 Absolute Maximum Ratings

Note: Absolute maximum ratings are defined as ratings, which when being exceeded may lead to destruction of the integrated circuit. For the same reason make sure, that any capacitor that will be connected to pin 11 (VCC) is discharged before assembling the application circuit.  $T_o=25^{\circ}\text{C}$  unless otherwise specified.

**Table 3 Absolute Maximum Ratings**

Parameter	Symbol	Limit Values		Unit	Remarks
		min.	max.		
Switching drain current, pulse width $t_p$ limited by $T_j=150^{\circ}\text{C}$	$I_s$	-	4.03	A	
Pulse drain current, pulse width $t_p$ limited by $T_j=150^{\circ}\text{C}$	$I_{D\_Plus}$	-	6.12	A	
Avalanche energy, repetitive $t_{AR}$ limited by max. $T_j=150^{\circ}\text{C}^1$	$E_{AR}$	-	0.15	mJ	
Avalanche current, repetitive $t_{AR}$ limited by max. $T_j=150^{\circ}\text{C}^1$	$I_{AR}$	-	1.5	A	
VCC Supply Voltage	$V_{VCC}$	-0.3	27	V	
FB Voltage	$V_{FB}$	-0.3	5.5	V	
BA Voltage	$V_{BA}$	-0.3	5.5	V	
CS Voltage	$V_{CS}$	-0.3	5.5	V	
Junction Temperature	$T_j$	-40	150	$^{\circ}\text{C}$	Controller & CoolMOS™
Storage Temperature	$T_s$	-55	150	$^{\circ}\text{C}$	
Thermal Resistance (Junction–Ambient)	$R_{thJA}$	-	110	K/W	
Soldering temperature, wavesoldering only allowed at leads	$T_{sold}$	-	260	$^{\circ}\text{C}$	1.6 mm (0.063 in.) from case for 10 s
ESD Capability (incl. Drain Pin)	$V_{ESD}$	-	2	kV	Human body model <sup>2</sup>

<sup>1</sup> Repetitive avalanche causes additional power losses that can be calculated as  $P_{AV}=E_{AR} \cdot f$

<sup>2</sup> According to EIA/JESD22-A114-B (discharging a 100 pF capacitor through a 1.5 kW series resistor)

Electrical Characteristics

4.2 Absolute Maximum Ratings

Note: Within the operating range the IC operates as described in the functional description.

Table 4 Absolute Maximum Ratings

Parameter	Symbol	Limit Values		Unit	Remarks
		min.	max.		
VCC Supply Voltage	$V_{VCC}$	$V_{VCCoff}$	25	V	Max value limited due to Vcc OVP
Junction Temperature of Controller	$T_{jCon}$	-40	130	°C	Max value limited due to thermal shut down of controller
Junction Temperature of CoolMOS™	$T_{jCoolMOS}$	-40	150	°C	

4.3 Characteristics

4.3.1 Supply Section

Note: The electrical characteristics involve the spread of values within the specified supply voltage and junction temperature range  $T_J$  from  $-40\text{ °C}$  to  $125\text{ °C}$ . Typical values represent the median values, which are related to  $25\text{ °C}$ . If not otherwise stated, a supply voltage of  $V_{VCC} = 18\text{ V}$  is assumed.

Table 5 Supply Section

Parameter	Symbol	Limit Values			Unit	Test Condition
		min.	typ.	max.		
Start Up Current	$I_{VCCstart}$	-	150	250	μA	$V_{VCC} = 17\text{ V}$
VCC Charge Current	$I_{VCCcharge1}$	-	-	5.0	mA	$V_{VCC} = 0\text{ V}$
	$I_{VCCcharge2}$	0.55	0.9	1.60	mA	$V_{VCC} = 1\text{ V}$
	$I_{VCCcharge3}$	-	0.7	-	mA	$V_{VCC} = 17\text{ V}$
Leakage Current of Start Up Cell and CoolMOS™	$I_{startLeak}$	-	0.2	50	μA	$V_{Drain} = 450\text{ V}$ at $T_j = 100\text{ °C}$
Supply Current with Inactive Gate	$I_{VCCsup1}$	-	1.5	2.5	mA	
Supply Current with Active Gate	$I_{VCCsup2}$	-	2.7	3.4	mA	$I_{FB} = 0\text{ A}$
Supply Current in Auto Restart Mode with Inactive Gate	$I_{VCCrestart}$	-	250	-	μA	$I_{FB} = 0\text{ A}$
Supply Current in Active Burst Mode with Inactive Gate	$I_{VCCburst1}$	-	450	950	μA	$V_{FB} = 2.5\text{ V}$
	$I_{VCCburst2}$	-	450	950	μA	$V_{VCC} = 11.5\text{ V}, V_{FB} = 2.5\text{ V}$
VCC Turn-On Threshold	$V_{VCCon}$	17.0	18.0	19.0	V	
VCC Turn-Off Threshold	$V_{VCCoff}$	9.8	10.5	11.2	V	
VCC Turn-On/Off Hysteresis	$V_{VCCchys}$	-	7.5	-	V	

Electrical Characteristics

4.3.2 Internal Voltage Reference

Table 6 Internal Voltage Reference

Parameter	Symbol	Limit Values			Unit	Test Condition
		min.	typ.	max.		
Trimmed Reference Voltage	$V_{REF}$	4.90	5.00	5.10	V	measured at pin FB $I_{FB} = 0$

4.3.3 PWM Section

Table 7 PWM Section

Parameter	Symbol	Limit Values			Unit	Test Condition
		min.	typ.	max.		
Fixed Oscillator Frequency	$f_{OSC1}$	54.5	65.0	73.5	kHz	
	$f_{OSC2}$	59.8	65.0	70.2		
Frequency Jittering Range	$f_{jitter}$	-	±2.6	-	kHz	$T_j = 25^\circ C$
Frequency Jittering period	$T_{jitter}$	-	4.0	-	ms	$T_j = 25^\circ C$
Max. Duty Cycle	$D_{max}$	0.70	0.75	0.80		
Min. Duty Cycle	$D_{min}$	0	-	-		$V_{FB} < 0.3 V$
PWM-OP Gain	$A_v$	3.1	3.3	3.5		
Voltage Ramp Offset	$V_{Offset-}$	-	0.67	-	V	
$V_{FB}$ Operating Range Min Level	$V_{FBmin}$	-	0.5	-	V	
$V_{FB}$ Operating Range Max level	$V_{FBmax}$	-	-	4.3	V	CS=1 V, limited by Comparator C4 <sup>1</sup>
FB Pull-Up Resistor	$R_{FB}$	9	15.4	23	kΩ	

4.3.4 Soft Start time

Table 8 Soft Start time

Parameter	Symbol	Limit Values			Unit	Test Condition
		min.	typ.	max.		
Soft Start time	$t_{SS}$	-	20	-	ms	

<sup>1</sup> The parameter is not subjected to production test - verified by design/characterization

Electrical Characteristics

4.3.5 Control Unit

Table 9 Control Unit

Parameter	Symbol	Limit Values			Unit	Test Condition
		min.	typ.	max.		
Clamped $V_{BA}$ voltage during Normal Operating Mode	$V_{BAclmp}$	0.85	0.9	0.95	V	$V_{FB} = 4\text{ V}$
Blanking time voltage limit for Comparator C3	$V_{BKc3}$	3.85	4.00	4.15	V	
Over Load & Open Loop Detection Limit for Comparator C4	$V_{FBC4}$	3.85	4.00	4.15	V	
Active Burst Mode Level for Comparator C5	$V_{FBC5}$	1.25	1.35	1.45	V	
Active Burst Mode Level for Comparator C6a	$V_{FBC6a}$	3.35	3.50	3.65	V	After Active Burst Mode is entered
Active Burst Mode Level for Comparator C6b	$V_{FBC6b}$	2.88	3.00	3.12	V	After Active Burst Mode is entered
Overvoltage Detection Limit for Comparator C1	$V_{VCCOVP1}$	19.5	20.5	21.5	V	$V_{FB} = 5\text{ V}$
Overvoltage Detection Limit for Comparator C2	$V_{VCCOVP2}$	25.0	25.5	26.5	V	
Auto-restart Enable level at BA pin	$V_{AE}$	0.25	0.33	0.4	V	>30 ms
Charging current at BA pin	$I_{BK}$	9.5	13.0	16.9	$\mu\text{A}$	Charge starts after the built-in 20 ms blanking
Thermal Shutdown <sup>1</sup>	$T_{jSD}$	130	140	150	$^{\circ}\text{C}$	Controller
Built-in Blanking Time for Overload Protection or enter Active Burst Mode	$t_{BK}$	-	20	-	ms	without external capacitor at BA pin
Inhibit Time for Auto-Restart enable	$t_{IHAE}$	-	1.0	-	ms	Count when $V_{VCC} > 18\text{ V}$
Spike Blanking Time before Auto-Restart Protection	$t_{Spike}$	-	30	-	$\mu\text{s}$	

Note: The trend of all voltage levels in the Control Units is the same regarding the deviation except  $V_{VCCOVP}$

<sup>1</sup> The parameter is not subjected to production test - verified by design/characterization. The thermal shutdown temperature refers to the junction temperature of the controller.

Electrical Characteristics

4.3.6 Current Limiting

Table 10 Current Limiting

Parameter	Symbol	Limit Values			Unit	Test Condition
		min.	typ.	max.		
Peak Current Limitation (incl. Propagation Delay)	$V_{CSth}$	0.95	1.03	1.10	V	$dV_{sense}/dt = 0.6 V/\mu s$ (Figure 21)
Peak Current Limitation during Active	$V_{CS2}$	0.29	0.34	0.38	V	
Leading Edge Blanking	$t_{LEB}$	-	220	-	ns	
CS Input Bias Current	$I_{CSbias}$	-1.6	-0.2	-	$\mu A$	$V_{CS} = 0 V$

4.3.7 CoolMOS™ Section

Table 11 CoolMOS™ Section

Parameter	Symbol	Limit Values			Unit	Test Condition
		min.	typ.	max.		
Drain Source Breakdown Voltage	$V_{(BR)DSS}$	650	-	-	V	$T_j = 110^\circ C$ , Refer to Figure 31 for other $V_{(BR)DSS}$ in different $T_j$
Drain Source On-Resistance	$R_{DSon}$	-	1.70 3.57	1.96 4.12	$\Omega$	$T_j = 25^\circ C$ $T_j = 125^\circ C^1$ at $I_D = 1.5 A$
Effective output capacitance, energy related	$C_{o(er)}$	-	11.63	-	pF	$V_{DS} = 0 V$ to $480 V^1$
Rise Time <sup>2</sup>	$t_{rise}$	-	30	-	ns	
Fall Time <sup>2</sup>	$t_{fall}$	-	30	-	ns	

<sup>1</sup> The parameter is not subjected to production test - verified by design/characterization

<sup>2</sup> Measured in a Typical Flyback Converter Application



CoolMOS™ Performance Characteristics

## 5 CoolMOS™ Performance Characteristics

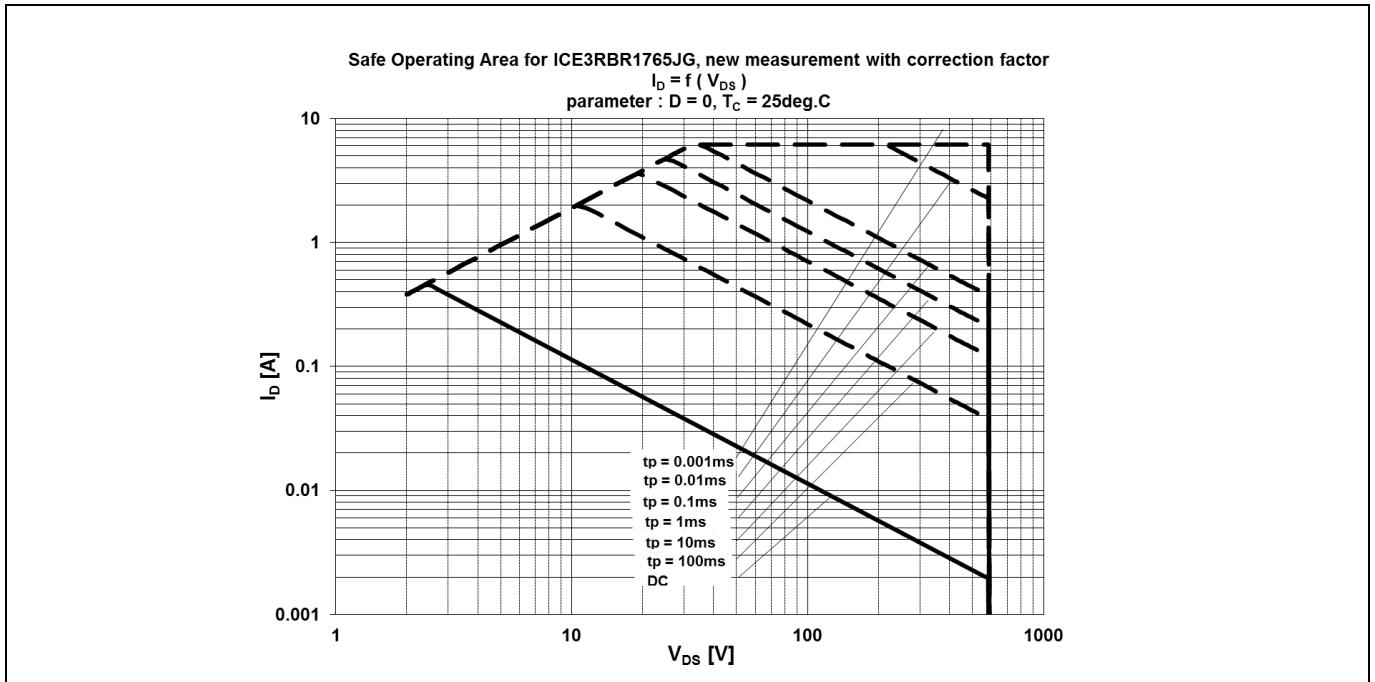

Figure 28 Safe Operating Area (SOA) curve for ICE3RBR1765JG

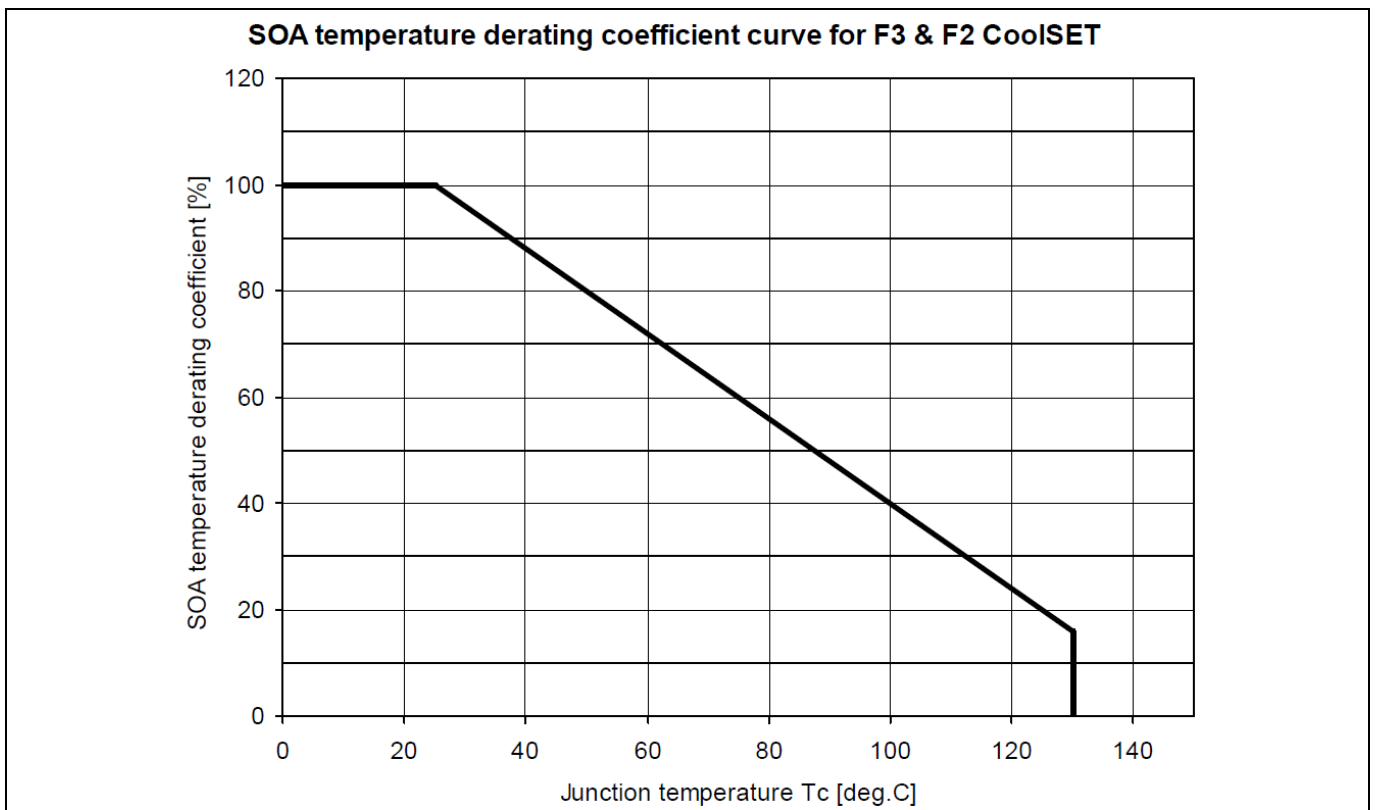

Figure 29 SOA temperature derating coefficient curve

CoolMOS™ Performance Characteristics

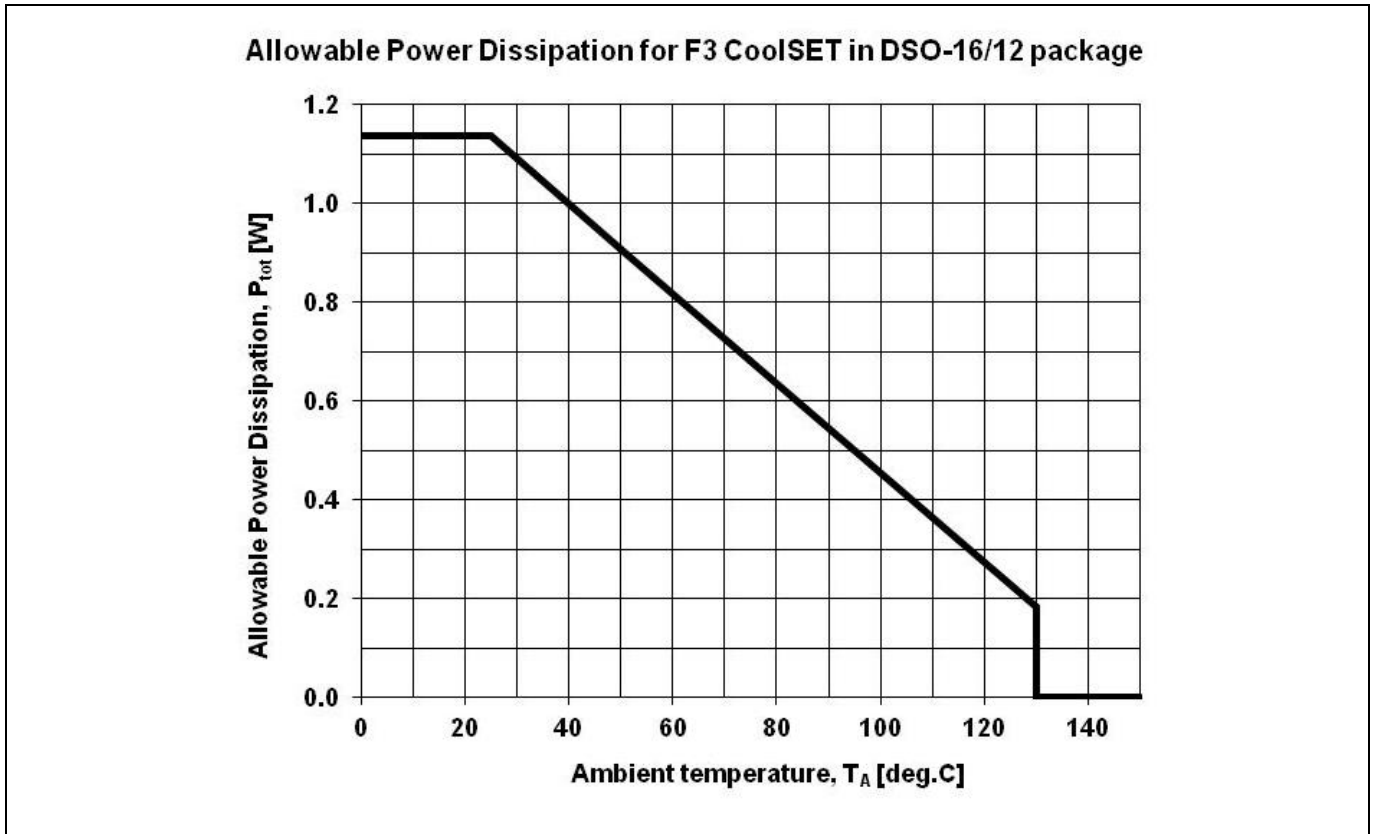

Figure 30 Power dissipation;  $P_{tot}=f(T_A)$

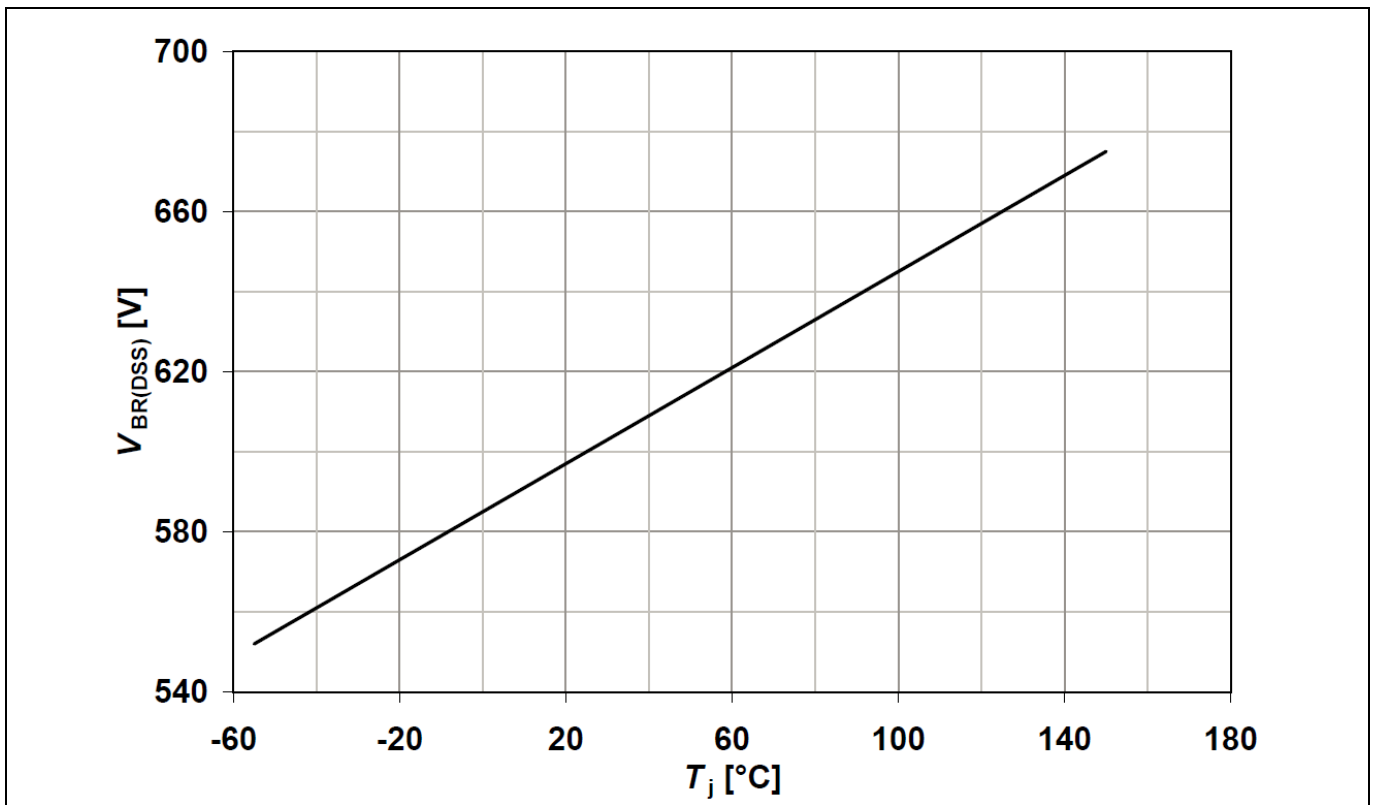

Figure 31 Drain-source breakdown voltage;  $V_{BR(DSS)}=f(T_j)$ ,  $I_D=0.25mA$

Input Power Curve

## 6 Input Power Curve

Two input power curves giving the typical input power versus ambient temperature are shown below;  $V_{IN}=85 V_{AC} \sim 265 V_{AC}$  (Figure 32) and  $V_{IN}=230 V_{AC} \pm 15\%$  (Figure 33). The curves are derived based on a typical discontinuous mode flyback model which considers either 50% maximum duty ratio or 100 V maximum secondary to primary reflected voltage (higher priority). The calculation is based on no copper area as heatsink for the device. The input power already includes the power loss at input common mode choke, bridge rectifier and the CoolMOS™. The device saturation current ( $I_{D\_Puls} @ T_j=125^\circ C$ ) is also considered.

To estimate the output power of the device, it is simply multiplying the input power at a particular operating ambient temperature with the estimated efficiency for the application. For example, a wide range input voltage (Figure 32), operating temperature is  $50^\circ C$ , estimated efficiency is 85%, then the estimated output power is 23 W ( $27.5 W \times 85\%$ ).

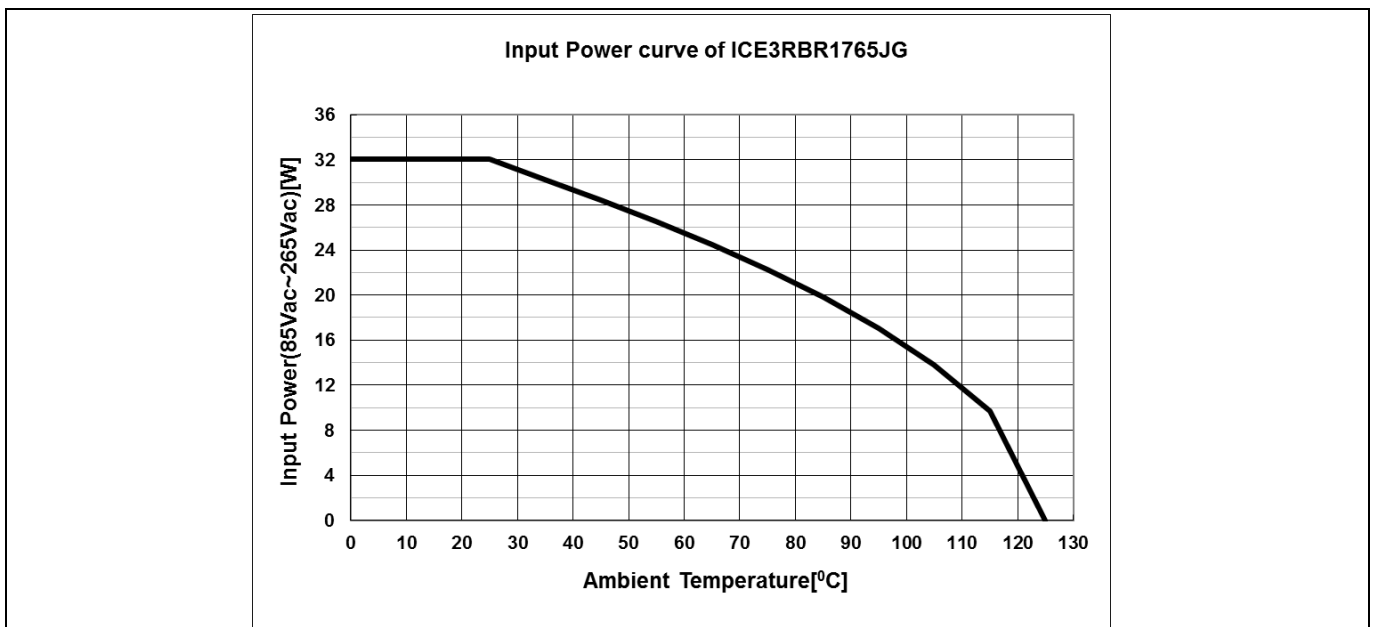

Figure 32 Input power curve  $V_{IN}=85 \sim 265 V_{AC}$ ;  $P_{in}=f(T_a)$

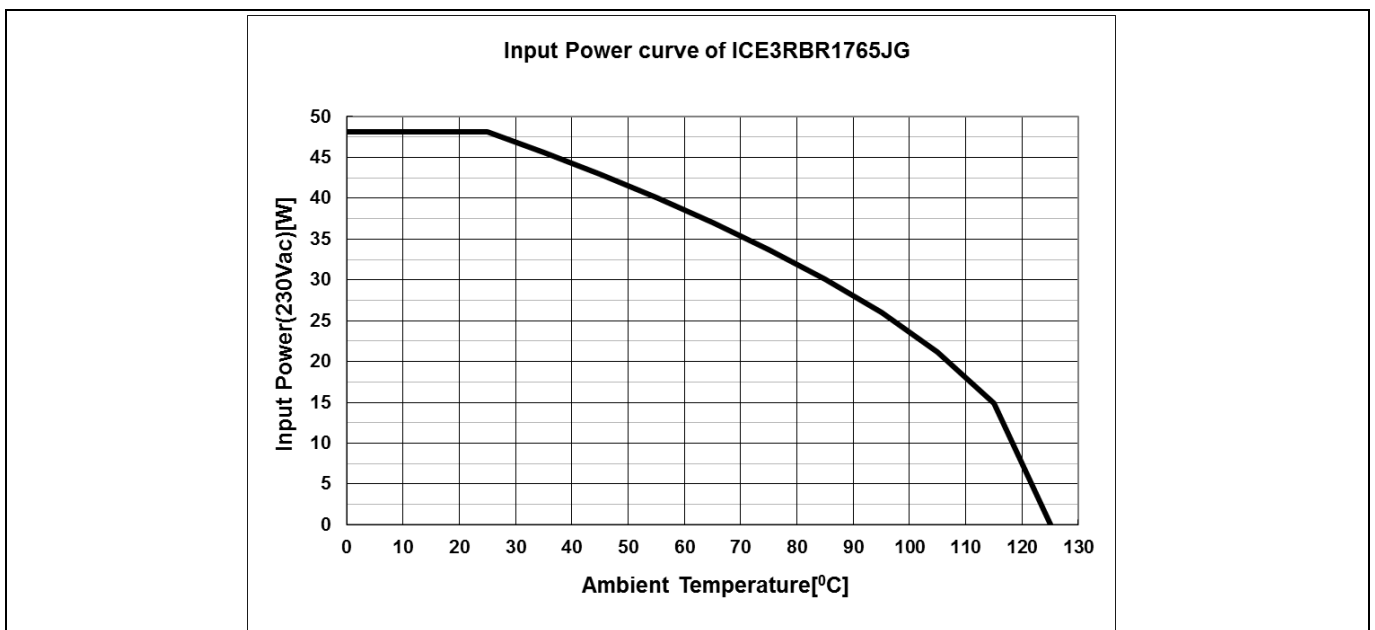

Figure 33 Input power curve  $V_{IN}=230 V_{AC}$ ;  $P_{in}=f(T_a)$

Outline Dimension

7 Outline Dimension

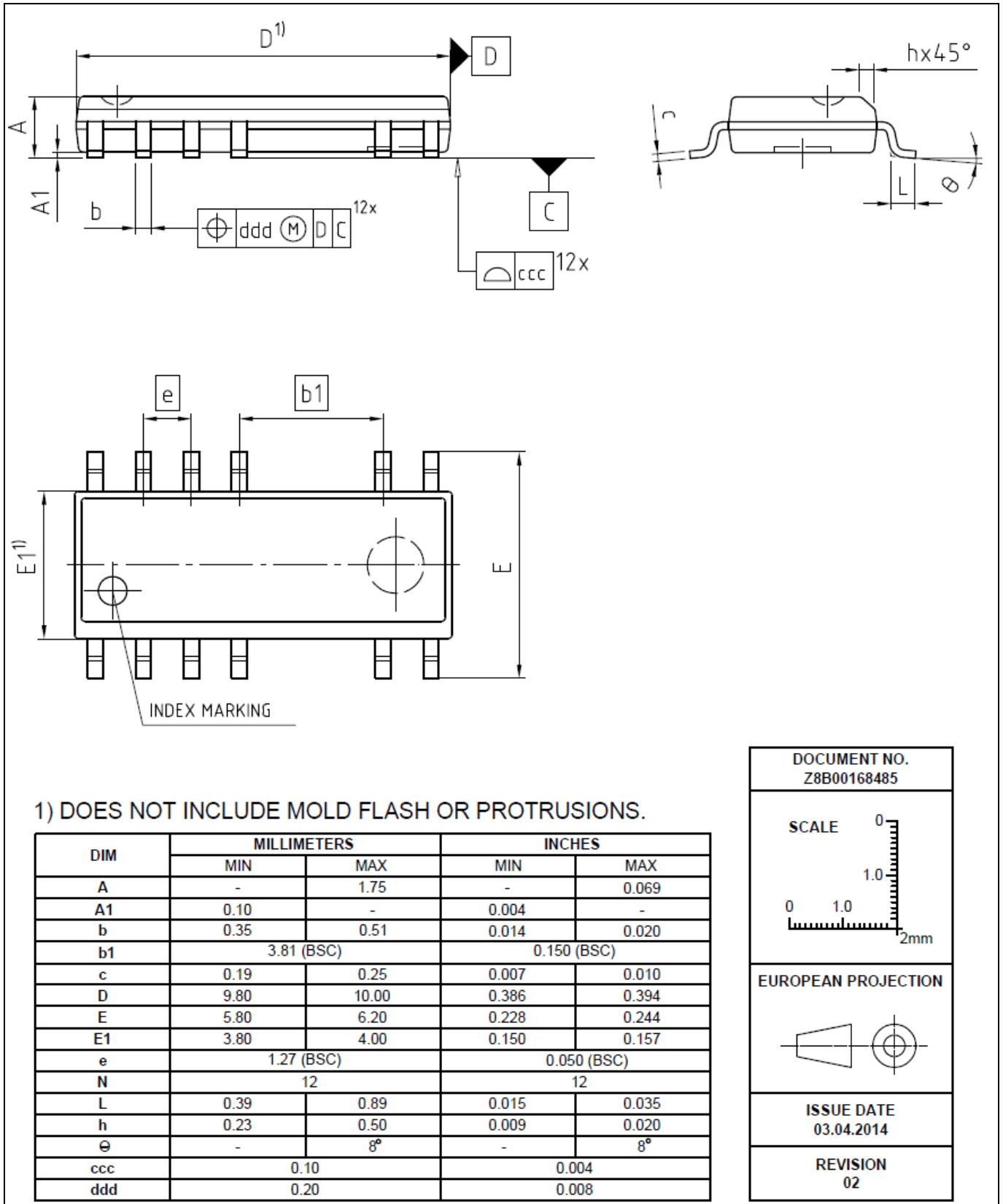

Figure 34 PG-DSO-12 (Pb-free lead plating Plastic Dual-in-Line Outline)

Marking

8 Marking

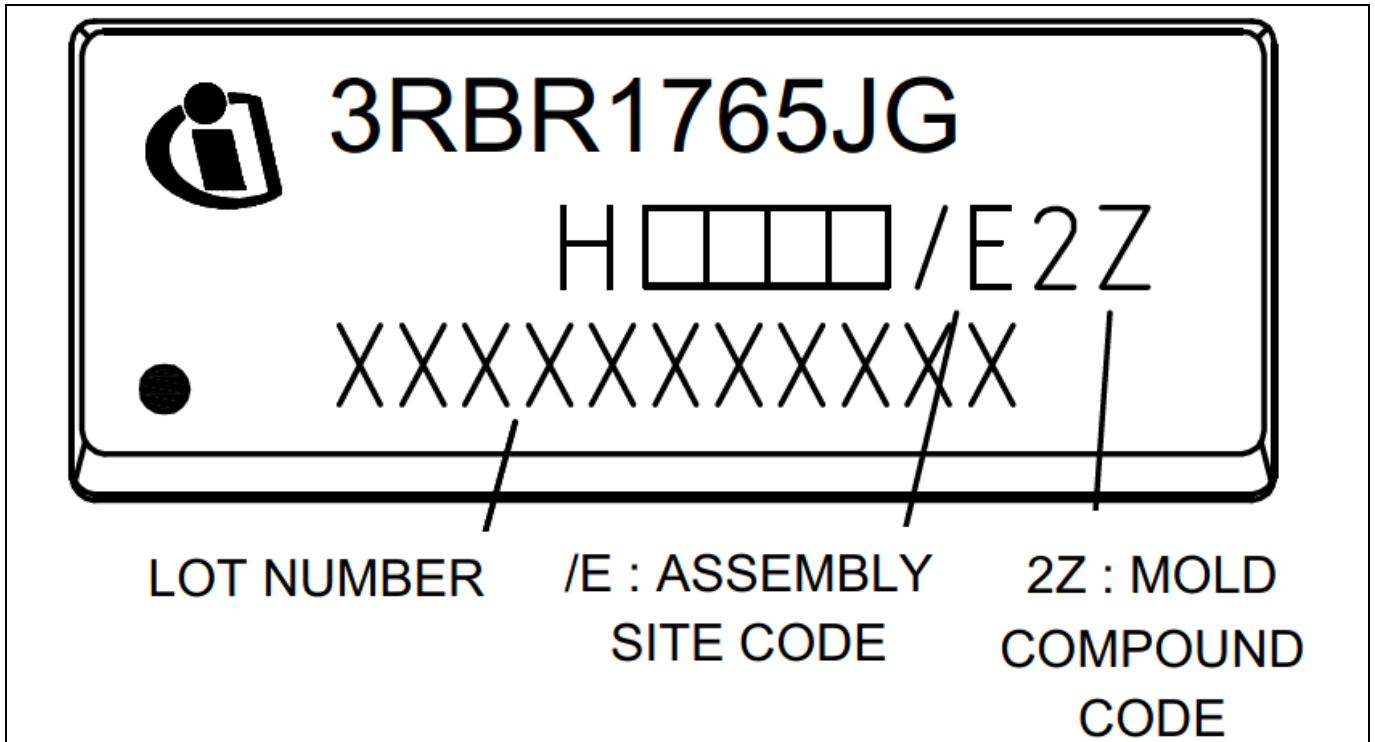

Figure 35 Marking for ICE3RBR1765JG



## Schematic for recommended PCB layout

- a. Spark Gap 3 and Spark Gap 4, input common mode choke, L1:  
Gap separation is around 1.5 mm (no safety concern)
  
  - b. Spark Gap 1 and Spark Gap 2, Live / Neutral to GROUND:  
These 2 Spark Gaps can be used when the lightning surge requirement is > 6 kV.  
230 V<sub>AC</sub> input voltage application, the gap separation is around 5.5mm  
115 V<sub>AC</sub> input voltage application, the gap separation is around 3mm
2. Add Y-capacitor (C2 and C3) in the Live and Neutral to ground even though it is a 2-pin input
  3. Add negative pulse clamping diode, D11 to the Current sense resistor, R12:  
The negative pulse clamping diode can reduce the negative pulse going into the CS pin of the CoolSET™ and reduce the abnormal behavior of the CoolSET™. The diode can be a fast speed diode such as 1N4148.  
The principle behind is to drain the high surge voltage from Live/Neutral to Ground without passing through the sensitive components such as the primary controller, IC11.

## Revision History

### Major changes since the last revision

Page or Reference	Description of change
1, 29	change marking

#### Trademarks of Infineon Technologies AG

AURIX™, C166™, CanPAK™, CIPOST™, CoolGaN™, CoolMOST™, CoolSET™, CoolSiC™, CORECONTROL™, CROSSAVE™, DAVE™, DI-POL™, DrBlade™, EasyPIM™, EconoBRIDGE™, EconoDUAL™, EconoPACK™, EconoPIM™, EiceDRIVER™, eupec™, FCOS™, HITFET™, HybridPACK™, Infineon™, ISOFACE™, IsoPACK™, i-Wafer™, MIPAQ™, ModSTACK™, my-d™, NovalithIC™, OmniTune™, OPTIGA™, OptiMOS™, ORIGA™, POWERCODE™, PRIMARION™, PrimePACK™, PrimeSTACK™, PROFET™, PRO-SIL™, RASIC™, REAL3™, ReverSave™, SatRIC™, SIEGET™, SIPMOS™, SmartLEWIS™, SOLID FLASH™, SPOC™, TEMPFET™, thinQ!™, TRENCHSTOP™, TriCore™.

Trademarks updated August 2015

#### Other Trademarks

All referenced product or service names and trademarks are the property of their respective owners.

**Edition 2017-06-13**

**Published by**

**Infineon Technologies AG**

**81726 München, Germany**

**© 2017 Infineon Technologies AG.**

**All Rights Reserved.**

**Do you have a question about this document?**

**Email: [erratum@infineon.com](mailto:erratum@infineon.com)**

**Document reference**

#### IMPORTANT NOTICE

The information given in this document shall in no event be regarded as a guarantee of conditions or characteristics ("Beschaffenheitsgarantie").

With respect to any examples, hints or any typical values stated herein and/or any information regarding the application of the product, Infineon Technologies hereby disclaims any and all warranties and liabilities of any kind, including without limitation warranties of non-infringement of intellectual property rights of any third party.

In addition, any information given in this document is subject to customer's compliance with its obligations stated in this document and any applicable legal requirements, norms and standards concerning customer's products and any use of the product of Infineon Technologies in customer's applications.

The data contained in this document is exclusively intended for technically trained staff. It is the responsibility of customer's technical departments to evaluate the suitability of the product for the intended application and the completeness of the product information given in this document with respect to such application.

For further information on the product, technology, delivery terms and conditions and prices please contact your nearest Infineon Technologies office ([www.infineon.com](http://www.infineon.com)).

#### WARNINGS

Due to technical requirements products may contain dangerous substances. For information on the types in question please contact your nearest Infineon Technologies office.

Except as otherwise explicitly approved by Infineon Technologies in a written document signed by authorized representatives of Infineon Technologies, Infineon Technologies' products may not be used in any applications where a failure of the product or any consequences of the use thereof can reasonably be expected to result in personal injury.



单击下面可查看定价，库存，交付和生命周期等信息

[>>Infineon Technologies\(英飞凌\)](#)