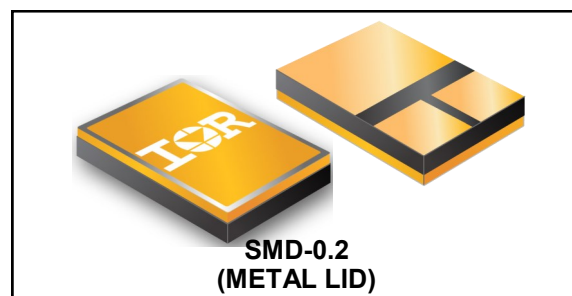


**RADIATION HARDENED  
 LOGIC LEVEL POWER MOSFET  
 SURFACE MOUNT (SMD-0.2)**
**250V, N-CHANNEL**  
 **TECHNOLOGY**
**Product Summary**

Part Number	Radiation Level	RDS(on)	I <sub>D</sub>
IRHLNM7S7214	100 kRads(Si)	1.1Ω	3.2A
IRHLNM7S3214	300 kRads(Si)	1.1Ω	3.2A

Refer to Page 9 for 2 Additional Part Numbers -  
 IRHLNMC7S7214 and IRHLNMC7S3214 (CERAMIC LID)


**Description**

IR HiRel R7 S-line Logic Level Power MOSFETs provide simple solution to interfacing CMOS and TTL control circuits to power devices in space and other radiation environments. The threshold voltage remains within acceptable operating limits over the full operating temperature and post radiation. This is achieved while maintaining single event gate rupture and single event burnout immunity.

The device is ideal when used to interface directly with most logic gates, linear IC's, micro-controllers, and other device types that operate from a 3.3-5V source. It may also be used to increase the output current of a PWM, voltage comparator or an operational amplifier where the logic level drive signal is available.

**Features**

- 5V CMOS and TTL Compatible
- Fast Switching
- Single Event Effect (SEE) Hardened
- Low Total Gate Charge
- Simple Drive Requirements
- Hermetically Sealed
- Ceramic Package
- Surface Mount
- Light Weight
- ESD Rating: Class 1B per MIL-STD-750, Method 1020

**Absolute Maximum Ratings**
**Pre-Irradiation**

Symbol	Parameter	Value	Units
I <sub>D1</sub> @ V <sub>GS</sub> = 4.5V, T <sub>C</sub> = 25°C	Continuous Drain Current	3.2	A
I <sub>D2</sub> @ V <sub>GS</sub> = 4.5V, T <sub>C</sub> = 100°C	Continuous Drain Current	2.0	
I <sub>DM</sub> @ T <sub>C</sub> = 25°C	Pulsed Drain Current ①	12.8	
P <sub>D</sub> @ T <sub>C</sub> = 25°C	Maximum Power Dissipation	23.2	W
	Linear Derating Factor	0.18	W/°C
V <sub>GS</sub>	Gate-to-Source Voltage	± 10	V
E <sub>AS</sub>	Single Pulse Avalanche Energy ②	17.6	mJ
I <sub>AR</sub>	Avalanche Current ①	3.2	A
E <sub>AR</sub>	Repetitive Avalanche Energy ①	2.32	mJ
dv/dt	Peak Diode Recovery dv/dt ③	11	V/ns
T <sub>J</sub> T <sub>STG</sub>	Operating Junction and Storage Temperature Range	-55 to + 150	°C
	Lead Temperature	300 (for 5s)	
	Weight	0.25 (Typical)	

For Footnotes, refer to the page 2.

### Electrical Characteristics @ T<sub>J</sub> = 25°C (Unless Otherwise Specified)

Symbol	Parameter	Min.	Typ.	Max.	Units	Test Conditions
BV <sub>DSS</sub>	Drain-to-Source Breakdown Voltage	250	—	—	V	V <sub>GS</sub> = 0V, I <sub>D</sub> = 250μA
ΔBV <sub>DSS</sub> /ΔT <sub>J</sub>	Breakdown Voltage Temp. Coefficient	—	0.25	—	V/°C	Reference to 25°C, I <sub>D</sub> = 1.0mA
R <sub>DS(on)</sub>	Static Drain-to-Source On-Resistance	—	—	1.1	Ω	V <sub>GS</sub> = 4.5V, I <sub>D2</sub> = 2.0A ④
V <sub>GS(th)</sub>	Gate Threshold Voltage	1.0	—	2.0	V	V <sub>DS</sub> = V <sub>GS</sub> , I <sub>D</sub> = 250μA
ΔV <sub>GS(th)</sub> /ΔT <sub>J</sub>	Gate Threshold Voltage Coefficient	—	-5.8	—	mV/°C	
G <sub>fs</sub>	Forward Transconductance	3.2	—	—	S	V <sub>DS</sub> = 10V, I <sub>D2</sub> = 2.0A ④
I <sub>DSS</sub>	Zero Gate Voltage Drain Current	—	—	1.0	μA	V <sub>DS</sub> = 200V, V <sub>GS</sub> = 0V
		—	—	10		V <sub>DS</sub> = 200V, V <sub>GS</sub> = 0V, T <sub>J</sub> = 125°C
I <sub>GSS</sub>	Gate-to-Source Leakage Forward	—	—	100	nA	V <sub>GS</sub> = 10V
	Gate-to-Source Leakage Reverse	—	—	-100		V <sub>GS</sub> = -10V
Q <sub>G</sub>	Total Gate Charge	—	—	13	nC	I <sub>D1</sub> = 3.2A
Q <sub>GS</sub>	Gate-to-Source Charge	—	—	5.8		V <sub>DS</sub> = 125V
Q <sub>GD</sub>	Gate-to-Drain ('Miller') Charge	—	—	4.3		V <sub>GS</sub> = 4.5V
t <sub>d(on)</sub>	Turn-On Delay Time	—	—	17	ns	V <sub>DD</sub> = 125V
T <sub>r</sub>	Rise Time	—	—	35		I <sub>D1</sub> = 3.2A
t <sub>d(off)</sub>	Turn-Off Delay Time	—	—	45		R <sub>G</sub> = 7.5Ω
t <sub>f</sub>	Fall Time	—	—	22		V <sub>GS</sub> = 5.0V
L <sub>S</sub> + L <sub>D</sub>	Total Inductance	—	6.8	—	nH	Measured from center of Drain pad to center of source pad
C <sub>iss</sub>	Input Capacitance	—	629	—	pF	V <sub>GS</sub> = 0V
C <sub>oss</sub>	Output Capacitance	—	68	—		V <sub>DS</sub> = 25V
C <sub>rss</sub>	Reverse Transfer Capacitance	—	2.6	—		f = 1.0MHz
R <sub>G</sub>	Gate Resistance	—	8.0	—	Ω	f = 1.0MHz, open drain

### Source-Drain Diode Ratings and Characteristics

Symbol	Parameter	Min.	Typ.	Max.	Units	Test Conditions
I <sub>S</sub>	Continuous Source Current (Body Diode)	—	—	3.2	A	
I <sub>SM</sub>	Pulsed Source Current (Body Diode) ①	—	—	12.8		
V <sub>SD</sub>	Diode Forward Voltage	—	—	1.2	V	T <sub>J</sub> = 25°C, I <sub>S</sub> = 3.2A, V <sub>GS</sub> = 0V ④
t <sub>rr</sub>	Reverse Recovery Time	—	—	250	ns	T <sub>J</sub> = 25°C, I <sub>F</sub> = 3.2A, V <sub>DD</sub> ≤ 25V
Q <sub>rr</sub>	Reverse Recovery Charge	—	—	1.24	μC	di/dt = 100A/μs ④
t <sub>on</sub>	Forward Turn-On Time	Intrinsic turn-on time is negligible (turn-on is dominated by L <sub>S</sub> +L <sub>D</sub> )				

### Thermal Resistance

Symbol	Parameter	Min.	Typ.	Max.	Units
R <sub>θJC</sub>	Junction-to-Case	—	—	5.4	°C/W

#### Footnotes:

- ① Repetitive Rating; Pulse width limited by maximum junction temperature.
- ② V<sub>DD</sub> = 50V, starting T<sub>J</sub> = 25°C, L = 3.45mH, Peak I<sub>L</sub> = 3.2A, V<sub>GS</sub> = 10V
- ③ I<sub>SD</sub> ≤ 3.2A, di/dt ≤ 1535A/μs, V<sub>DD</sub> ≤ 250V, T<sub>J</sub> ≤ 150°C
- ④ Pulse width ≤ 300 μs; Duty Cycle ≤ 2%
- ⑤ Total Dose Irradiation with V<sub>GS</sub> Bias. 10 volt V<sub>GS</sub> applied and V<sub>DS</sub> = 0 during irradiation per MIL-STD-750, Method 1019, condition A.
- ⑥ Total Dose Irradiation with V<sub>DS</sub> Bias. 200 volt V<sub>DS</sub> applied and V<sub>GS</sub> = 0 during irradiation per MIL-STD-750, Method 1019, condition A.

**Radiation Characteristics**



IR HiRel Radiation Hardened MOSFETs are tested to verify their radiation hardness capability. The hardness assurance program at IR HiRel is comprised of two radiation environments. Every manufacturing lot is tested for total ionizing dose (per notes 5 and 6) using the TO-3 package. Both pre- and post-irradiation performance are tested and specified using the same drive circuitry and test conditions in order to provide a direct comparison.

**Table1. Electrical Characteristics @ Tj = 25°C, Post Total Dose Irradiation ⑤⑥**

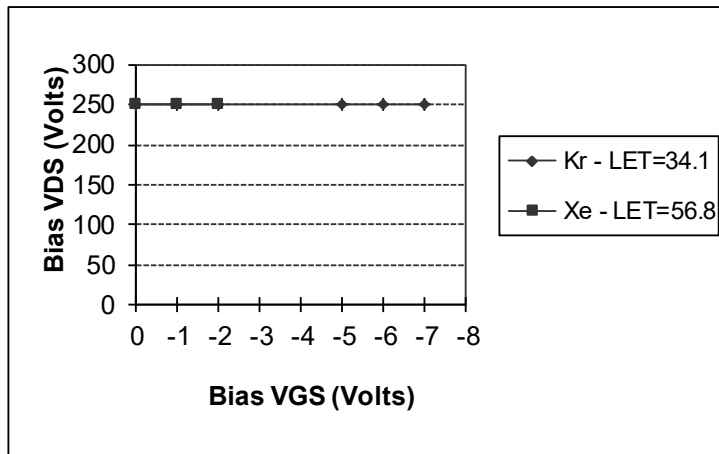
Symbol	Parameter	Up to 300 kRads (Si) <sup>1</sup>		Units	Test Conditions
		Min.	Max.		
BV <sub>DSS</sub>	Drain-to-Source Breakdown Voltage	250	—	V	V <sub>GS</sub> = 0V, I <sub>D</sub> = 250μA
V <sub>GS(th)</sub>	Gate Threshold Voltage	1.0	2.0	V	V <sub>DS</sub> = V <sub>GS</sub> , I <sub>D</sub> = 250μA
I <sub>GSS</sub>	Gate-to-Source Leakage Forward	—	100	nA	V <sub>GS</sub> = 10V
I <sub>GSS</sub>	Gate-to-Source Leakage Reverse	—	-100	nA	V <sub>GS</sub> = -10V
I <sub>DSS</sub>	Zero Gate Voltage Drain Current	—	1.0	μA	V <sub>DS</sub> = 200V, V <sub>GS</sub> = 0V
R <sub>DS(on)</sub>	Static Drain-to-Source <sup>④</sup> On-State Resistance (TO-3)	—	1.2	Ω	V <sub>GS</sub> = 4.5V, I <sub>D2</sub> = 2.0A
R <sub>DS(on)</sub>	Static Drain-to-Source <sup>④</sup> On-State Resistance (SMD-0.2)	—	1.1	Ω	V <sub>GS</sub> = 4.5V, I <sub>D2</sub> = 2.0A
V <sub>SD</sub>	Diode Forward Voltage	—	1.2	V	V <sub>GS</sub> = 0V, I <sub>S</sub> = 3.2A

1. Part numbers IRHLNM7S7214 and IRHLNM7S3214. Additional part numbers IRHLNMC7S7214, IRHLNMC7S3214 are listed on page 9

IR HiRel radiation hardened MOSFETs have been characterized in heavy ion environment for Single Event Effects (SEE). Single Event Effects characterization is illustrated in Fig. a and Table 2.

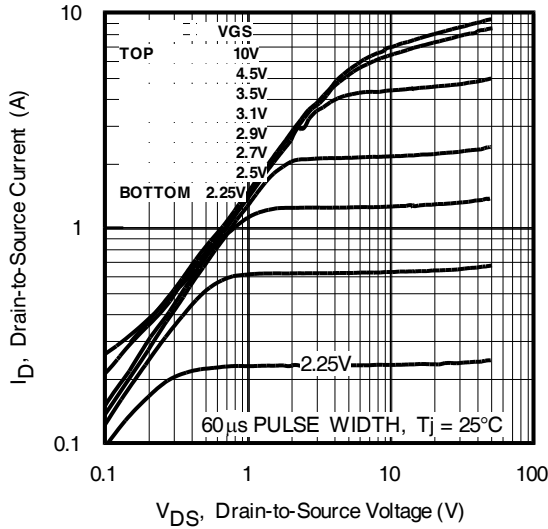
**Table 2. Typical Single Event Effect Safe Operating Area**

ION	LET (MeV/(mg/cm <sup>2</sup> ))	Energy (MeV)	Range (μm)	VDS (V)					
				@ VGS = 0V	@ VGS = -1V	@ VGS = -2V	@ VGS = -5V	@ VGS = -6V	@ VGS = -7V
Kr	34.1	573	69.6	250	250	250	250	250	250
Xe	56.8	1010	79.7	250	250	250	—	—	—

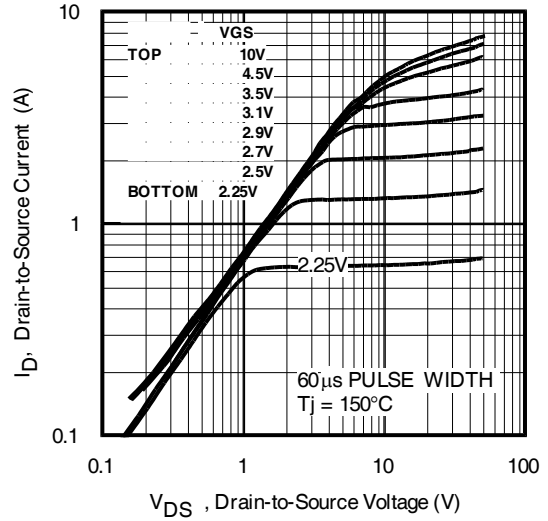


**Fig a. Typical Single Event Effect, Safe Operating Area**

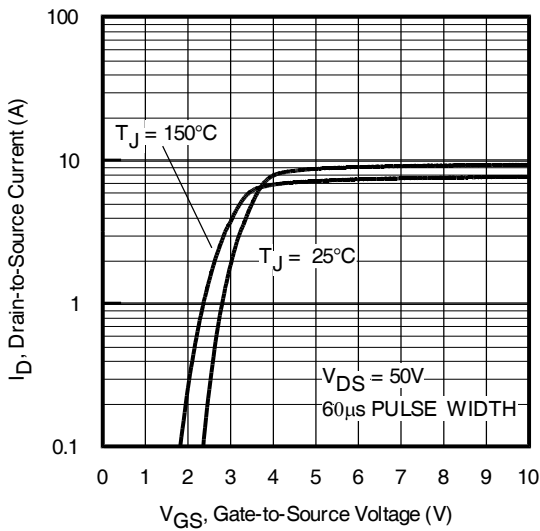
For Footnotes, refer to the page 2.



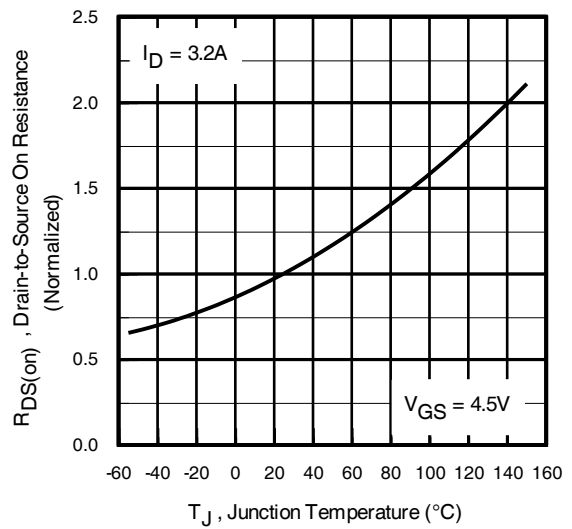
**Fig 1. Typical Output Characteristics**



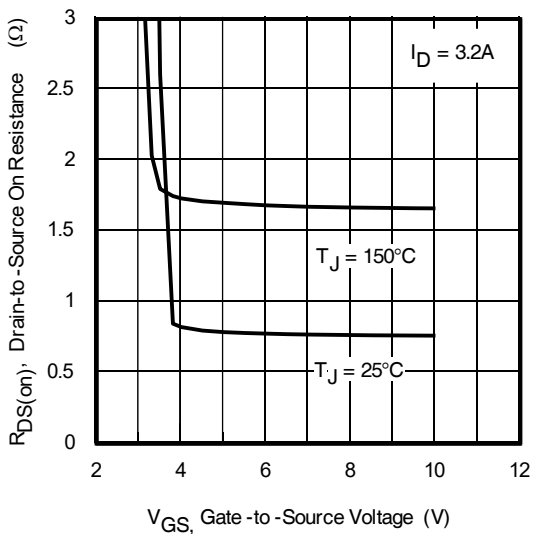
**Fig 2. Typical Output Characteristics**



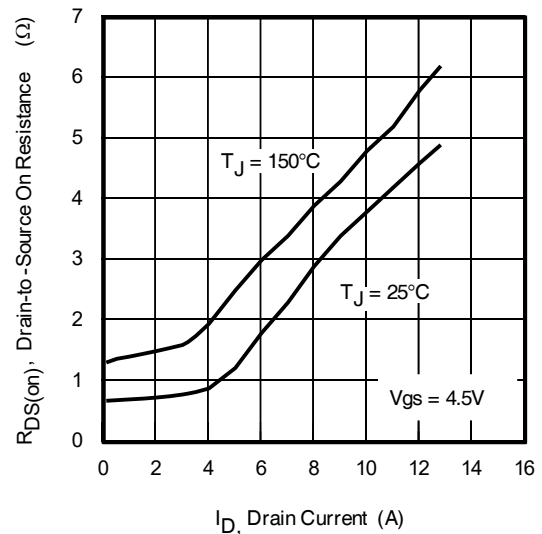
**Fig 3. Typical Transfer Characteristics**



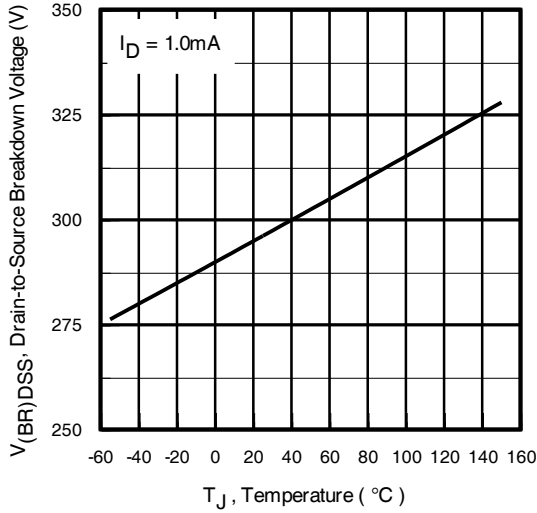
**Fig 4. Normalized On-Resistance Vs. Temperature**



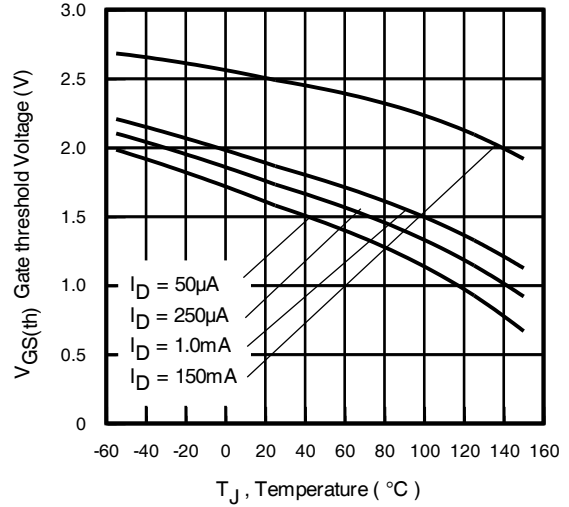
**Fig 5. Typical On-Resistance Vs Gate Voltage**



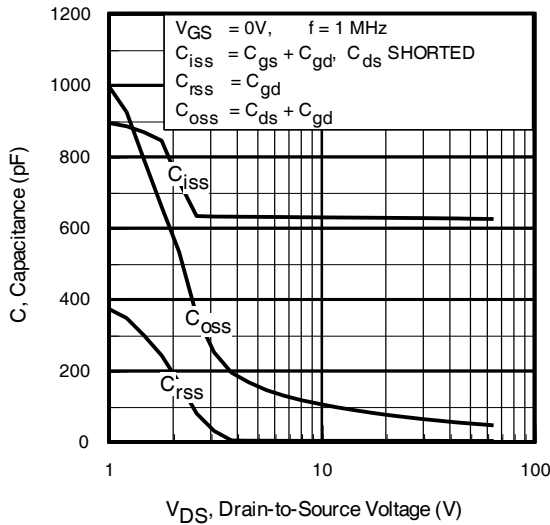
**Fig 6. Typical On-Resistance Vs Drain Current**



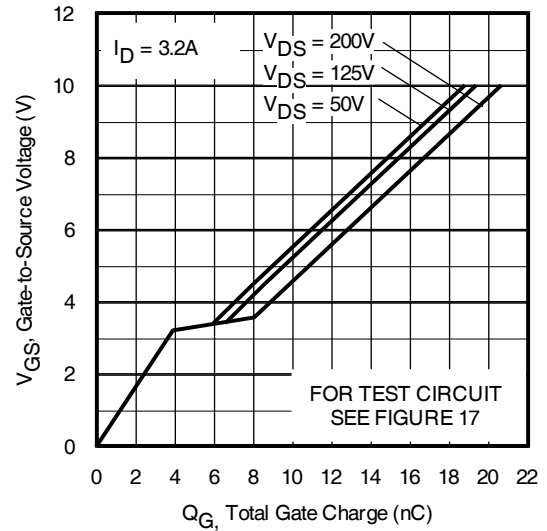
**Fig 7. Typical Drain-to-Source Breakdown Voltage Vs Temperature**



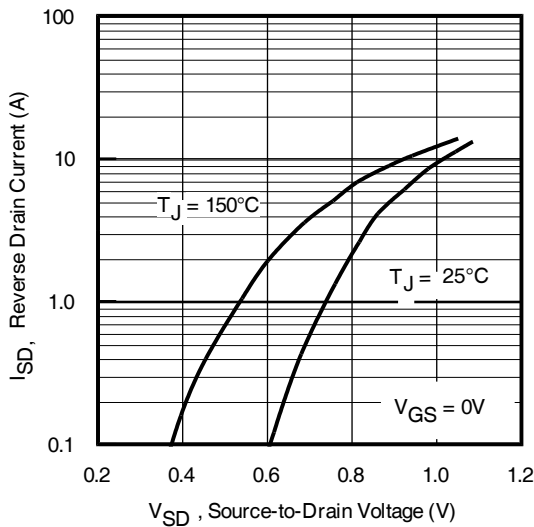
**Fig 8. Typical Threshold Voltage Vs Temperature**



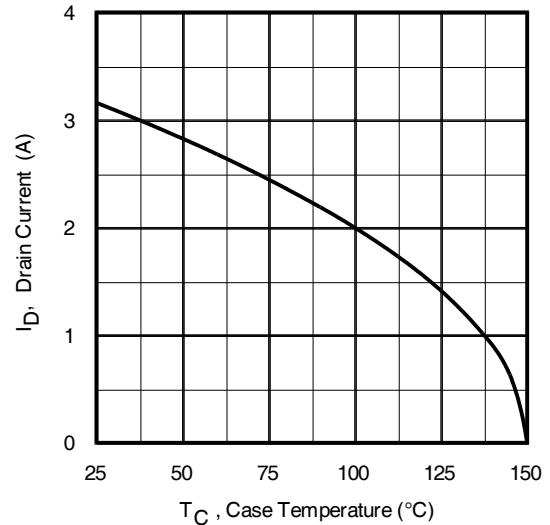
**Fig 9. Typical Capacitance Vs. Drain-to-Source Voltage**



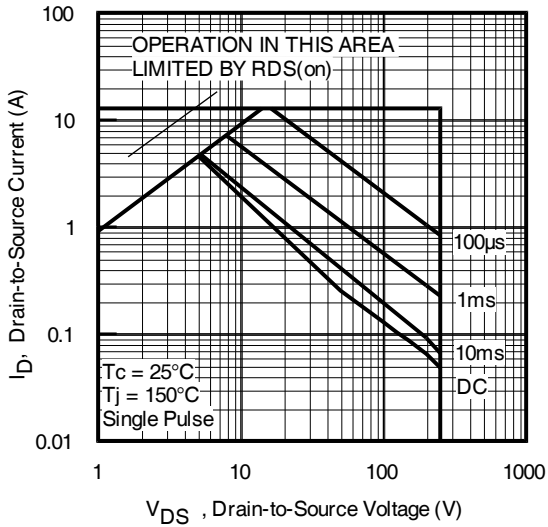
**Fig 10. Typical Gate Charge Vs. Gate-to-Source Voltage**



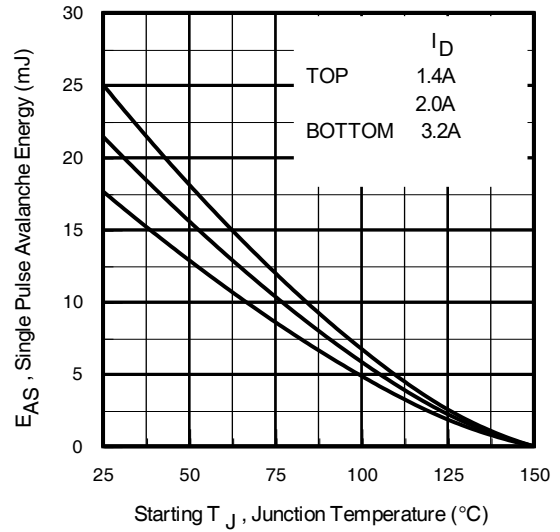
**Fig 11. Typical Source-Drain Diode Forward Voltage**



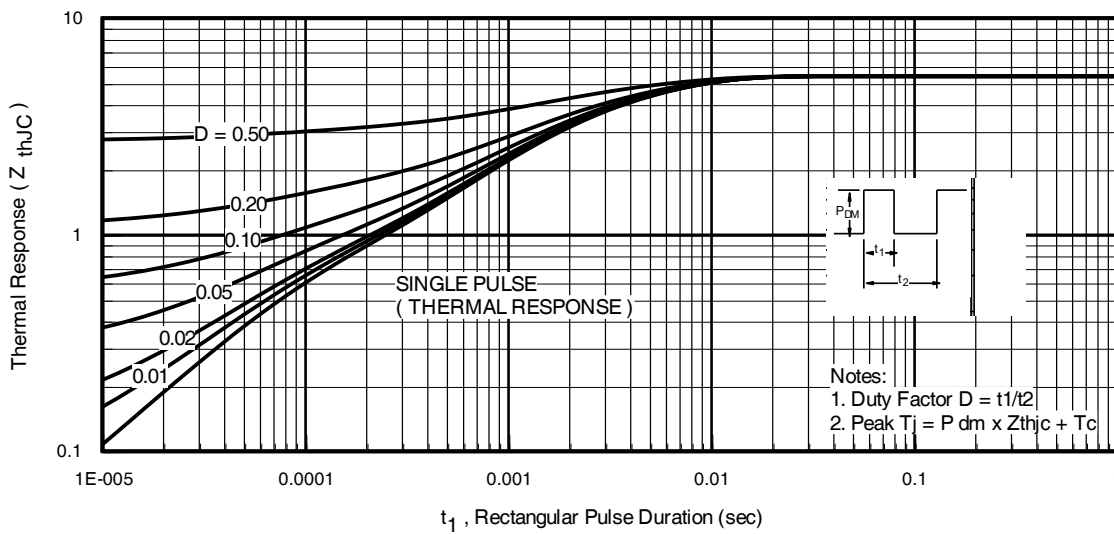
**Fig 12. Maximum Drain Current Vs. Case Temperature**



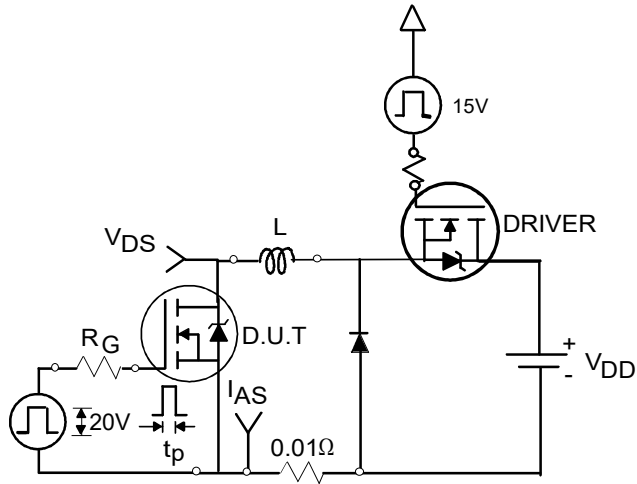
**Fig 13.** Maximum Safe Operating Area



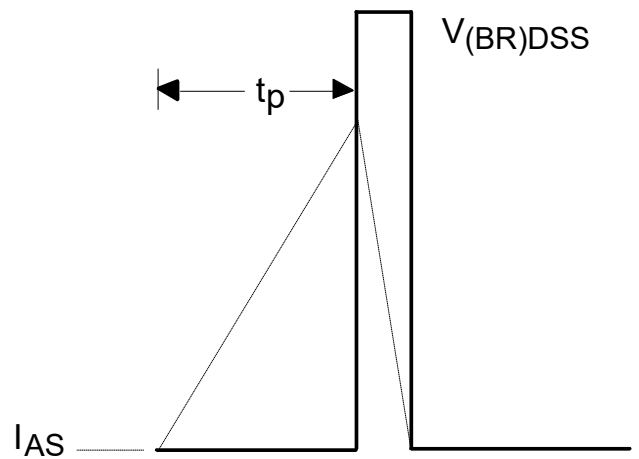
**Fig 14.** Maximum Avalanche Energy Vs. Drain Current



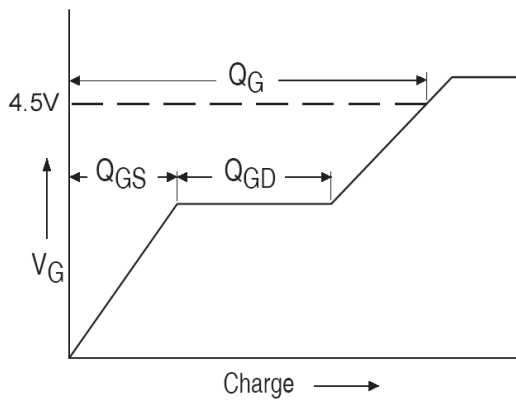
**Fig 15.** Maximum Effective Transient Thermal Impedance, Junction-to-Case



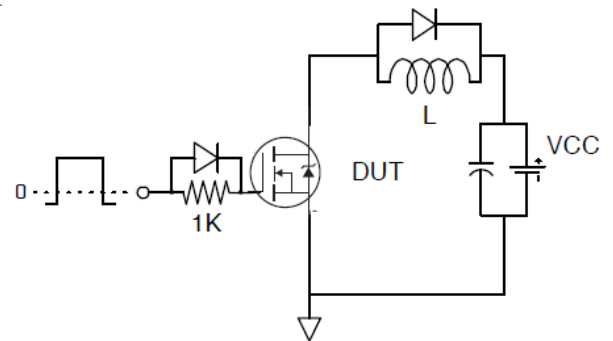
**Fig 16a.** Unclamped Inductive Test Circuit



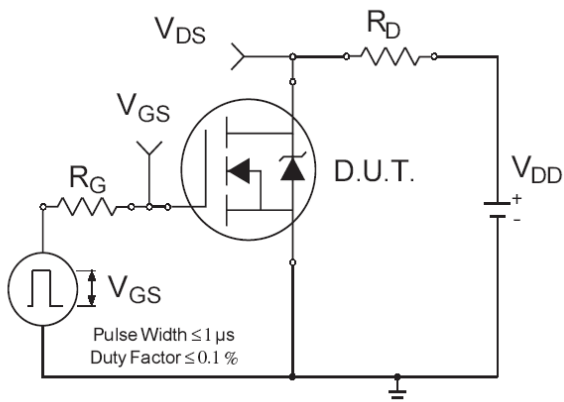
**Fig 16b.** Unclamped Inductive Wave-



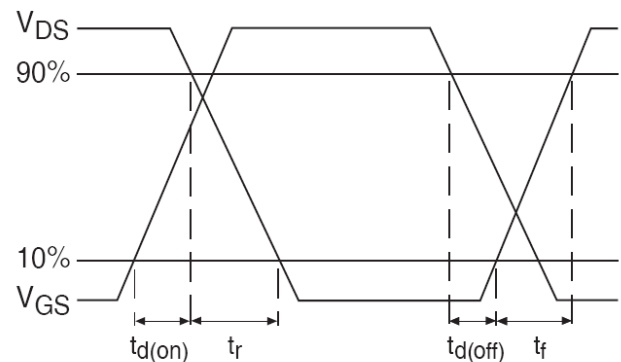
**Fig 17a.** Gate Charge Waveform



**Fig 17b.** Gate Charge Test Circuit

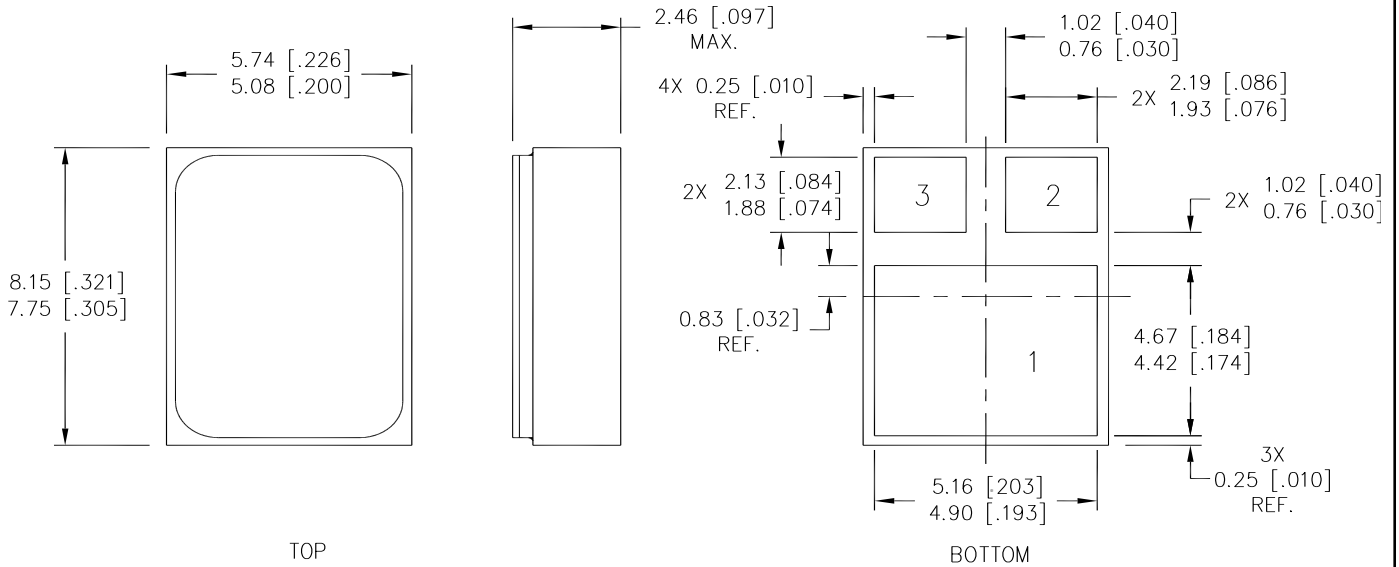


**Fig 18a.** Switching Time Test Circuit



**Fig 18b.** Switching Time Waveforms

**Case Outline and Dimensions - SMD-0.2 (Metal Lid)**



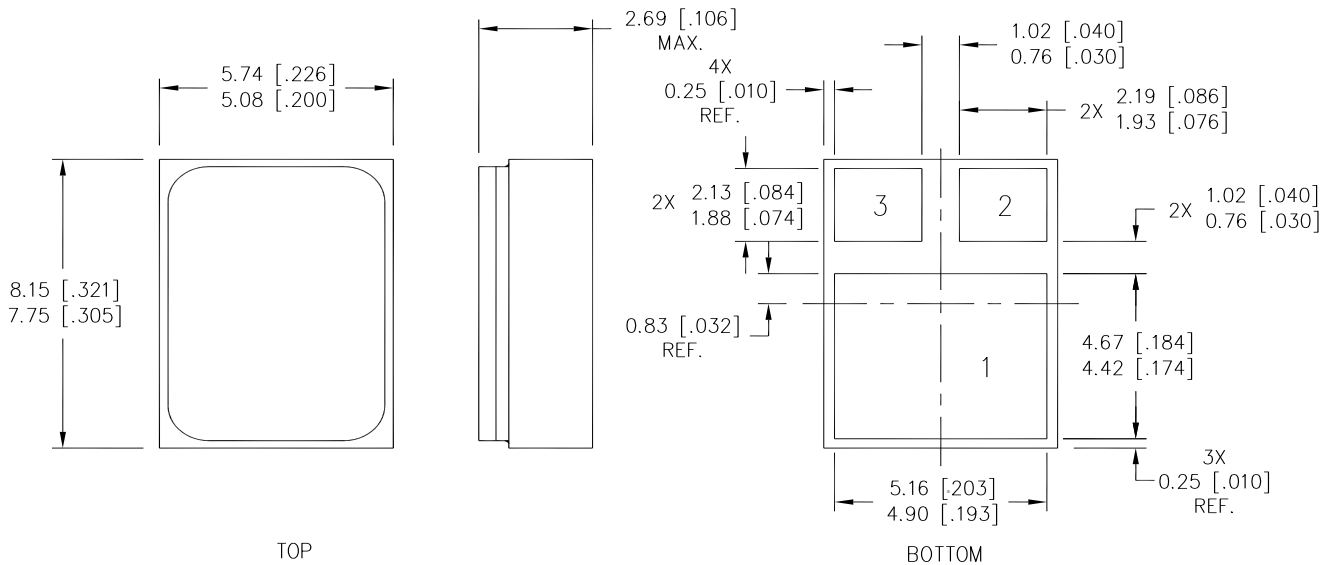
**NOTES:**

1. DIMENSIONING & TOLERANCING PER ASME Y14.5M-1994.
2. CONTROLLING DIMENSION: INCH.
3. DIMENSIONS ARE SHOWN IN MILLIMETERS [INCHES].

**PAD ASSIGNMENTS**

- 1 = DRAIN
- 2 = GATE
- 3 = SOURCE

**Case Outline and Dimensions - SMD-0.2 (Ceramic Lid)**



**NOTES:**

1. DIMENSIONING & TOLERANCING PER ASME Y14.5M-1994.
2. CONTROLLING DIMENSION: INCH.
3. DIMENSIONS ARE SHOWN IN MILLIMETERS [INCHES].

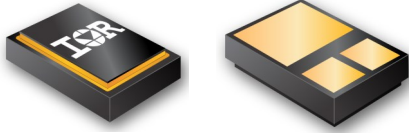
**PAD ASSIGNMENTS**

- 1 = DRAIN
- 2 = GATE
- 3 = SOURCE



**Additional Product Summary (continued from pages 1 and 3)**

**Product Summary**

Part Number	Radiation Level	RDS(on)	I <sub>D</sub>	 <p><b>SMD-0.2 (CERAMIC LID)</b></p>
IRHLNMC7S7214	100 kRads(Si)	1.1Ω	3.2A	
IRHLNMC7S3214	300 kRads(Si)	1.1Ω	3.2A	

### **IMPORTANT NOTICE**

The information given in this document shall be in no event regarded as guarantee of conditions or characteristic. The data contained herein is a characterization of the component based on internal standards and is intended to demonstrate and provide guidance for typical part performance. It will require further evaluation, qualification and analysis to determine suitability in the application environment to confirm compliance to your system requirements.

With respect to any example hints or any typical values stated herein and/or any information regarding the application of the product, Infineon Technologies hereby disclaims any and all warranties and liabilities of any kind including without limitation warranties on non- infringement of intellectual property rights and any third party.

In addition, any information given in this document is subject to customer's compliance with its obligations stated in this document and any applicable legal requirements, norms and standards concerning customer's product and any use of the product of Infineon Technologies in customer's applications.

The data contained in this document is exclusively intended for technically trained staff. It is the responsibility of any customer's technical departments to evaluate the suitability of the product for the intended applications and the completeness of the product information given in this document with respect to applications.

For further information on the product, technology, delivery terms and conditions and prices, please contact your local sales representative or go to ([www.infineon.com/hirel](http://www.infineon.com/hirel)).

### **WARNING**

Due to technical requirements products may contain dangerous substances. For information on the types in question, please contact your nearest Infineon Technologies office.

单击下面可查看定价，库存，交付和生命周期等信息

[>>Infineon Technologies\(英飞凌\)](#)