

## HIGH TEMPERATURE HYBRID DC-DC CONVERTER

**215°C, 5W, 28V Input, Single Output**

### Description

The VHB28 Series is a single output 5W hybrid, hermetically sealed DC-DC converter designed to operate in extremely high temperature environments with shock and vibration such as those encountered in oil exploration applications. Features include small size, low weight and high tolerance to environmental stresses such as temperature extremes, severe shock and vibration. Documentation including electrical stress and thermal analysis are available.

The converter incorporates a forward active clamp topology and internal EMI filter. All models include an external inhibit port and have an adjustable output voltage. They are delivered as a rugged 1.0" (25.4mm) W x 0.40" (10.2mm) H x 3.75" (95.3mm) L (plus flange) hybrid assemblies packaged in cold rolled steel (CRS) hermetic cans weighing less than 95 grams

Full environmental screening includes temperature cycling, hermeticity, constant acceleration, PIND and burn-in. Please refer to Device Screening table. Variations in electrical specifications and screening to meet custom requirements can be accommodated.

### Circuit Description

The VHB28 Series converter utilizes a forward active clamp topology. The nominal switching frequency is 440 kHz. Electrical isolation and tight output regulation are achieved through the use of a magnetically coupled feedback. The topology provides high line rejection

Output current is limited under any load fault condition to approximately 125% of rated. An overload condition causes the converter output to limit current and/or enter a shutdown/restart mode. The converter will remain in shutdown/restart mode until the load current is reduced below the overcurrent limit, at which time it will resume normal operation. This protects the converter from both overload and short circuit conditions.

### Features

- 17 to 34V DC Input Range
- Up to 5W Output Power
- Output Voltage Options: 3.3V, 5V, 12V, 15V
- Internal EMI Filter
- Minimum Efficiency 75% @ 25°C
- -35°C to +215°C Operating Temperature
- Life > 500 hours @ 215°C
- Low Sleep Current (< 5mA)
- 100MΩ @ 500V DC Isolation @ 25°C
- Under-Voltage Lockout Protection
- Short Circuit and Overload Protection
- Output Adjust (+/-5% of nominal)
- External Inhibit
- Compact Assembly: (plus flange)  
1.0" (25.4mm) W x 0.40" (10.2mm) H x 3.75" (95.3mm) L
- Low Weight < 95g

### Applications

- Down Hole Exploration Tools

## Specifications

Absolute Maximum Ratings		Recommended Operating Conditions	
Input Voltage range	-0.5V <sub>DC</sub> to +40V <sub>DC</sub>	Input Voltage range	17V <sub>DC</sub> to 34V <sub>DC</sub>
Output power	Internally limited	Output power	0 to Max. Rated
Lead Temperature	+300°C for 10 seconds	Operating temperature	-35°C to +215°C
Operating Case temperature	-35°C to +215°C		
Storage temperature	-45°C to +125°C		

## Electrical Performance Characteristics

Parameter	Conditions -35°C ≤ T <sub>C</sub> ≤ +215°C V <sub>IN</sub> = 28V DC ± 5%, C <sub>L</sub> = 0 Unless otherwise specified Note 2	Subgroup Note 1	VHB2803R3S TARGET		VHB2805S		VHB2812S PRELIMINARY		VHB2815S PRELIMINARY		Unit
			Min	Max	Min	Max	Min	Max	Min	Max	
Input voltage	Guaranteed to turn on	1,2,3	17	34	17	34	17	34	17	34	V
Output voltage (V <sub>OUT</sub> )	I <sub>OUT</sub> = 100% of rated load	1,3	3.26	3.40	4.95	5.15	11.88	12.36	14.85	15.45	V
		2	3.13	3.40	4.75	5.15	11.14	12.36	14.25	15.45	V
Output power (P <sub>OUT</sub> )	V <sub>IN</sub> = 17V, 28V, 34V, Note 4	1,2,3	0	5	0	5	0	5	0	5	W
Output current (I <sub>OUT</sub> )	V <sub>IN</sub> = 17V, 28V, 34V, Note 4	1,2,3	0	1.0	0	1.0	0	1.0	0	1.0	A
Line regulation (V <sub>RLINE</sub> )	V <sub>IN</sub> = 17V, 28V, 34V I <sub>OUT</sub> = no load, 50%, 100% of rated load	1,2,3	-1.0	1.0	-1.0	1.0	-1.0	1.0	-1.0	1.0	%
Load regulation (V <sub>RLOAD</sub> )	V <sub>IN</sub> = 17V, 28V, 34V I <sub>OUT</sub> = 10%, 50%, 100% of rated load	1	-1.0	1.0	-1.0	1.0	-1.0	1.0	-1.0	1.0	%
		2,3	-2.0	2.0							
Input current (no load) (I <sub>IN</sub> )	I <sub>OUT</sub> = 0 (Enable wire open)	1,2,3		50		50		50		50	mA
Input ripple current	I <sub>OUT</sub> = 100% of rated load BW = 10MHz With internal EMI filter	1,2,3		25		25		25		25	mA <sub>p-p</sub>
Input current (inhibited)	Enable wire shorted to Input Return wire	1,2,3		5		5		5		5	mA
Input under-voltage lockout	Turn-on (input increasing)	1,2,3		16.0		16.5		16.0		16.0	V
	Turn-off (input decreasing)	1,2,3	12.0		12.0		12.0		12.0		
	Hysteresis	1,2	0.7		0.7		0.7		0.7		
		3	0.4		0.4		0.4		0.4		
Output ripple voltage (V <sub>RIP</sub> )	V <sub>IN</sub> = 17V, 28V, 34V, I <sub>OUT</sub> = 100% of rated load with internal filter only Notes 3 & 5	1,2,3		50		50		50		50	mV <sub>p-p</sub>
Efficiency (E <sub>FF</sub> )	I <sub>OUT</sub> = 100% of rated load, Note 3	1	77		78		76		78		%
		2	74		75		75		75		
		3	71		72		70		72		

For Notes to Electrical Performance Characteristics Table, refer to page 4

**Electrical Performance Characteristics (continued)**

Parameter	Conditions -35°C ≤ T <sub>C</sub> ≤ +215°C V <sub>IN</sub> = 28V DC ± 5%, C <sub>L</sub> = 0 Unless otherwise specified Note 2	Subgroup Note 1	VHB2803R3S TARGET		VHB2805S		VHB2812S PRELIMINARY		VHB2815S PRELIMINARY		Unit	
			Min	Max	Min	Max	Min	Max	Min	Max		
Switching frequency (F <sub>s</sub> )	Pin Sync. In open	1,2,3	400	500	400	500	400	500	400	500	kHz	
<b>Synchronization input</b>												
Frequency range	Note 3	1,3	400	500	400	500	400	500	400	500	kHz	
		2	350	550	350	550	350	550	350	550	kHz	
Pulse amplitude (high)		1,2,3	3	5.1	3	5.1	3	5.1	3	5.1	V	
Pulse amplitude (low)		1,2,3	0	0.5	0	0.5	0	0.5	0	0.5	V	
Pulse rise time		1,2,3		50		50		50		50	ns	
Pulse duty cycle		1,2,3	25	50	25	50	25	50	25	50	%	
<b>Enable input (inhibit)</b>												
Open circuit voltage	Note 3	1,2,3	5.0	5.3	5.0	5.3	5.0	5.3	5.0	5.3	V	
Drive current (sink)			30	100	30	100	30	100	30	100	μA	
Voltage range			1.2	1.6	1.2	1.6	1.2	1.6	1.2	1.6	V	
Current limit point	V <sub>OUT</sub> = 90% of nominal	1,2,3	105	150	105	150	105	150	105	150	%	
Power dissipation (PD)	Short Circuit, Overload (load fault)	1,2,3		3		3		3		3	W	
<b>Load transient response</b>												
Amplitude	Load steps, 50% to/from 100%. Notes 7, 8	4,5,6	-330	330	-500	500	-500	500	-500	500	mV	
Recovery				200		200		200		200	μs	
Amplitude	Load steps, 10% to/from 50%. Notes 7, 8	4,5,6	-330	330	-500	500	-500	500	-500	500	mV	
Recovery			4,5		200		200		200		200	μs
			6		300		300		300		300	
<b>Line transient response</b>												
Amplitude	Input voltage step 17V to/from 34V I <sub>OUT</sub> = 100% of rated load. Notes 6, 8, 9	4,5,6	-5.0	+5.0	-5.0	+5.0	-5.0	+5.0	-5.0	+5.0	%	
Recovery				200		200		200		200	ms	

For Notes to Electrical Performance Characteristics Table, refer to page 4

**Electrical Performance Characteristics (continued)**

Parameter	Conditions -35°C ≤ T <sub>C</sub> ≤ +215°C V <sub>IN</sub> = 28V DC ± 5%, C <sub>L</sub> = 0 Unless otherwise specified Note 2	Subgroup Note 1	VHB2803R3S TARGET		VHB2805S		VHB2812S PRELIMINARY		VHB2815S PRELIMINARY		Unit
			Min	Max	Min	Max	Min	Max	Min	Max	
<b>Turn-on response</b>											
Overshoot (V <sub>OS</sub> )	I <sub>OUT</sub> = no load 100% of rated load, Note 10	4,5,6		600		600		720		750	mV
Turn-on delay (T <sub>DLY</sub> )	I <sub>OUT</sub> = no load 100% of rated load, Note 10	4,5,6	3	75	2	55	2	55	2	55	ms

Parameter	Conditions -35°C ≤ T <sub>C</sub> ≤ +215°C V <sub>IN</sub> = 28V DC ± 5%, C <sub>L</sub> = 0 Unless otherwise specified Note 2	Subgroup Note 1	VHB2803R3S TARGET		VHB2805S		VHB2812S PRELIMINARY		VHB2815S PRELIMINARY		Unit
			Min	Max	Min	Max	Min	Max	Min	Max	
Capacitive load (C <sub>L</sub> )	I <sub>OUT</sub> = 100% of rated load No effect on DC performance Note 6	1		1000		1000		1000		1000	μF
Line rejection	30Hz to 50kHz, Note 3	1	40	60	40	60	40	60	40	60	dB
Isolation	Input to output or any pin to case except case pin, test at 25°C and 500V <sub>DC</sub>	1	100		100		100		100		MΩ
Device mass		1	85	95	85	95	85	95	85	95	g

**Notes for Electrical Performance Characteristics Table**

- Subgroup 1, 4 is +25°C, Subgroup 2, 5 is +215 °C and subgroup 3, 6 is -35 °C. Subgroup 1, 2 and 3 are static tests. Subgroup 4, 5 and 6 are dynamic tests.
- Output unadjusted.
- Rated load is 5W at 1A unless otherwise specified.
- Parameter is verified during line and load regulation tests.
- Tested using a 20 kHz to 20 MHz bandwidth limit.
- Capacitive load may be any value from 0 to the maximum limit without compromising DC performance.
- Load transient rate of change, Transition time > 10μs.
- Recovery time is measured from the initiation of the transient to where V<sub>OUT</sub> has returned to within ±1% of its steady state value.
- Rise time and Fall time of Line transient should not be less than 100μs.
- Turn-on delay time from either a step application of input power or a logical low to high transition on the Enable to V<sub>OUT</sub> = 90% nominal.

**Technical Notes:**

**1. Brief Circuit Explanation with Block Diagram:**

**Figure 1. Block Diagram showing Topology of VHB Converters**

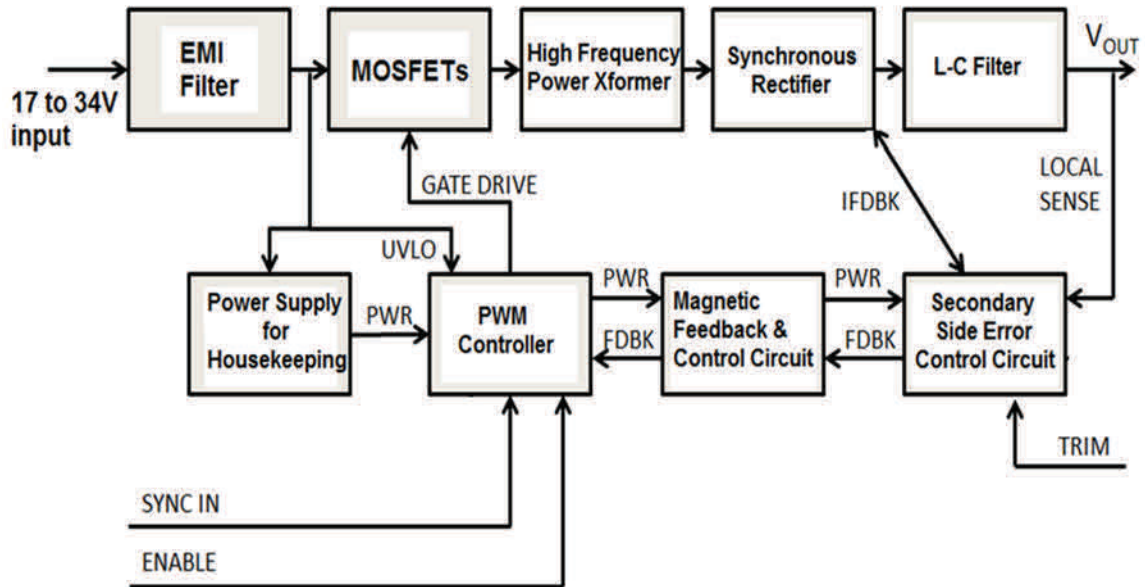

In the Block Diagram Figure 1, blocks on the top represent flow of power and the blocks on the bottom represent control circuitry. There are two substrates used in building this. Primary substrate, which houses all circuits that are connected to the input bus of 28V<sub>DC</sub> nominal, and, secondary substrate, which houses circuitry that are connected to the output. Facilities such as Synch In, Enable, Output Adjust are provided for user convenience. Figure 2 shows basic circuit elements with their functions

**Figure 2.- Functional Block Diagram of VHB Converter**

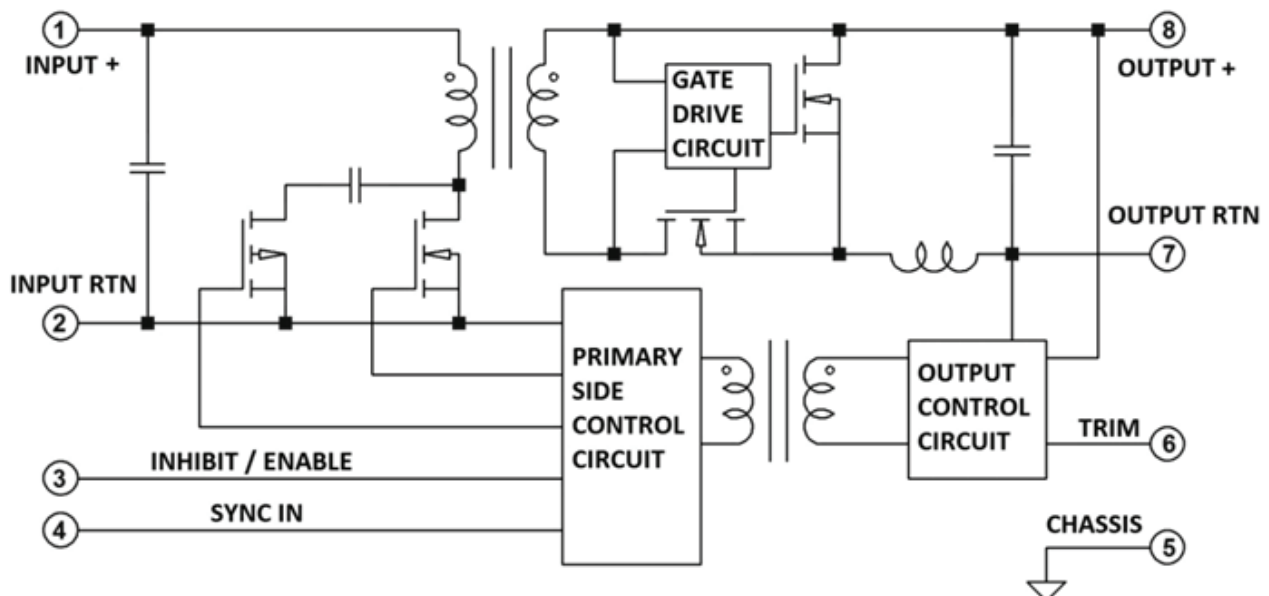

## 2. Inhibiting Converter Output:

As an alternative to application and removal of the DC voltage to the input, the user can control the VHB converter output by providing TTL compatible, positive logic signal to Inhibit pin and Input Return. Inhibit signal is internally pulled “high” so that when not used, an open connection on the Inhibit pin permits normal converter operation. When its use is desired, a logical “low” on this port will shut the converter down.

## 3. Synchronization of Multiple Converters:

When operating multiple converters, system requirements often may demand operation of the converters at a common frequency. To accommodate this requirement, the VHB series of converters provide a synchronization input. The Sync Input port permits synchronization of a VHB converter to any compatible external frequency source operating between 400 kHz and 500 kHz. This input signal should be referenced to the Input Return and has a 10% to 90% duty cycle. Compatibility requires transition times less than 100ns, maximum low level of +0.8V and a minimum high level of +2.0V. When external synchronization is not required, the Sync In pin should be left unconnected thereby permitting the converter to operate at its own internally set frequency.

## 4. Measuring Output ripple of VHB:

VHB converter’s output ripple should be measured per prescribed procedure to get reliable values. Figure 3 defines noise and ripple of any power supply or DC to DC Converter. Figure 4 shows how an oscilloscope and associated external R-C components should be connected to get true value of output ripple at full load.

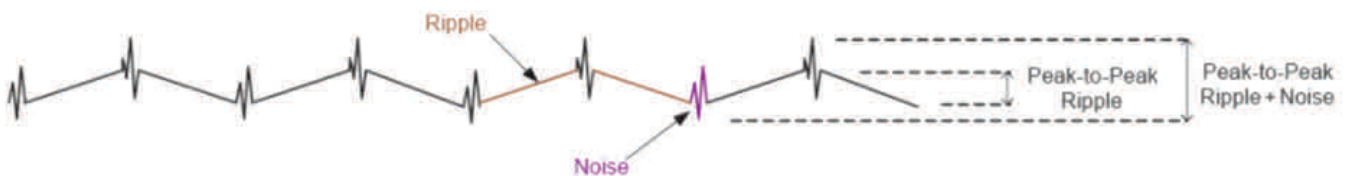

**Figure 3. Pictorial Definition of O/P noise and ripple of any Converter**

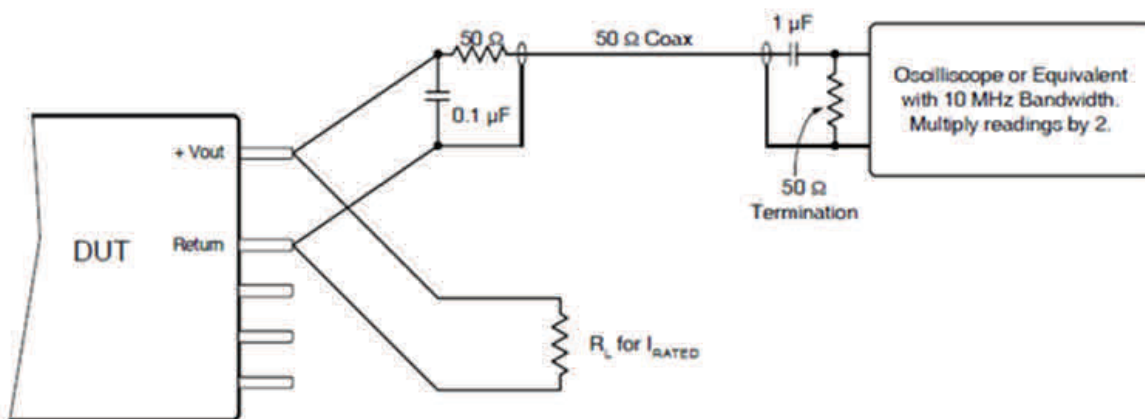

All wires of VHB28XXS can be terminated in an open box with pins so that all measurements are easily done

Because of the high frequency content of this ripple, special measurement techniques must be employed so that correct measurements are obtained. On a 200 MHz or 500 MHz oscilloscope, one should limit the bandwidth of measurement to 10 MHz.

The actual ripple voltage measurement must be carefully made in order not to induce error voltages in the test equipment. Therefore, the conventional ground clip on an oscilloscope probes (see Figure 5) should never be used in this type of measurement. This clip, when placed in a field of radiated high frequency energy, acts as an antenna or inductive pickup loop, creating an extraneous voltage that is not part of the output noise of the converter.

**Figure 5. Oscilloscope probe**

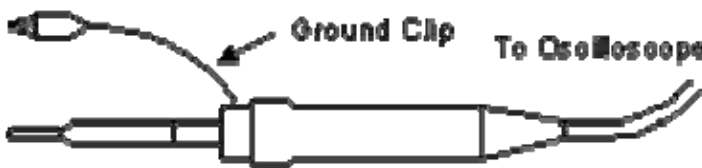

**Figure 6. correct method to use the oscilloscope probe.**

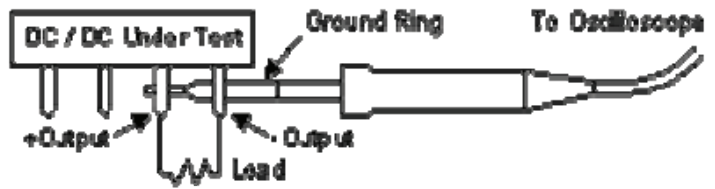

**5. Efficiency of VHB:**

Figure 7 shows efficiency vs. output power of VHB converter for different input voltages measured at operating case temperature of 215°C.

**Figure 7. VHB2805S- % Efficiency vs. output power in watts at 215°C**

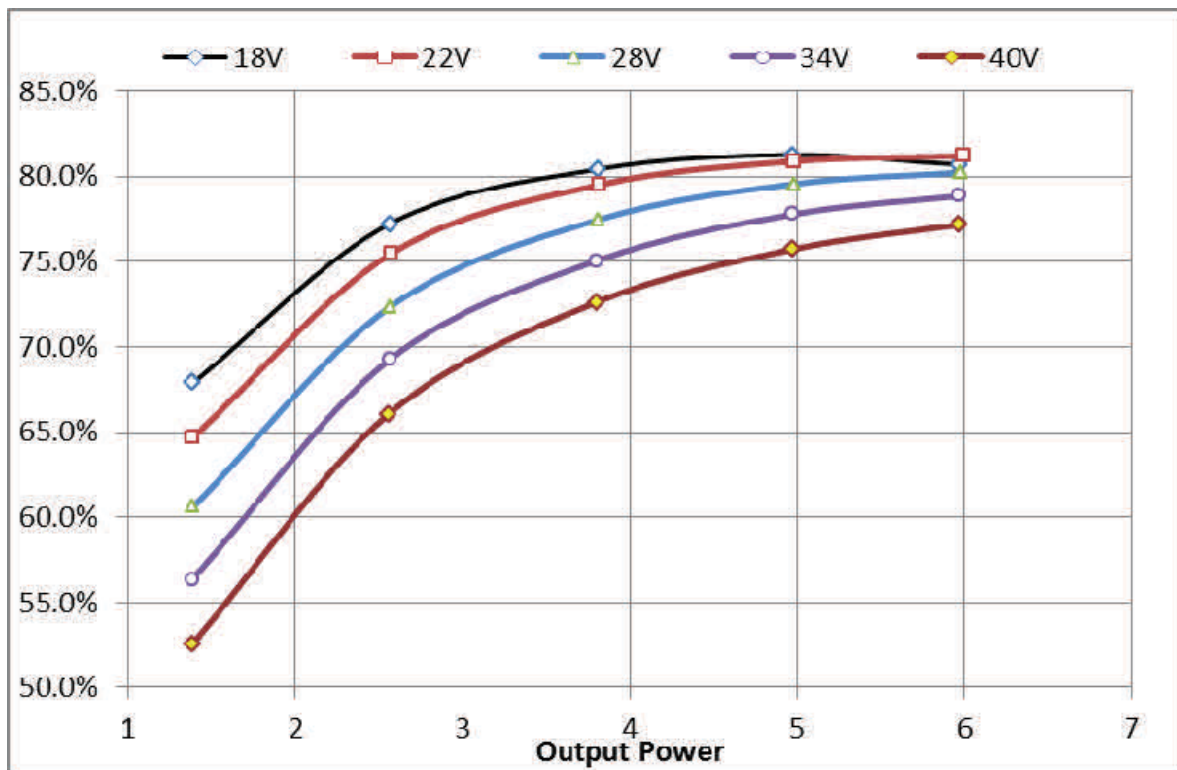

### 6. Output Voltage Adjust:

It is possible to adjust output voltage and also trim it. The resistor required for a given output voltage is provided in the table below and the connections for R1 and R2 are shown in Figure 8.

R1 (ohm)	Open	806	909	1050	1240	1500	1910	2550	3920	8060	Short
R2 (ohm)	Short	12700	4320	2610	1910	1500	1240	1050	931	825	Open
$V_o$	4.77	4.80	4.85	4.90	4.95	5.00	5.05	5.10	5.15	5.20	5.25

**Figure 8. Output Adjust Resistor Connections.**

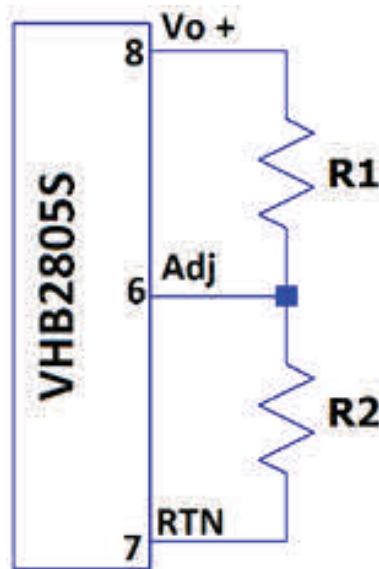



**Mechanical Outline**

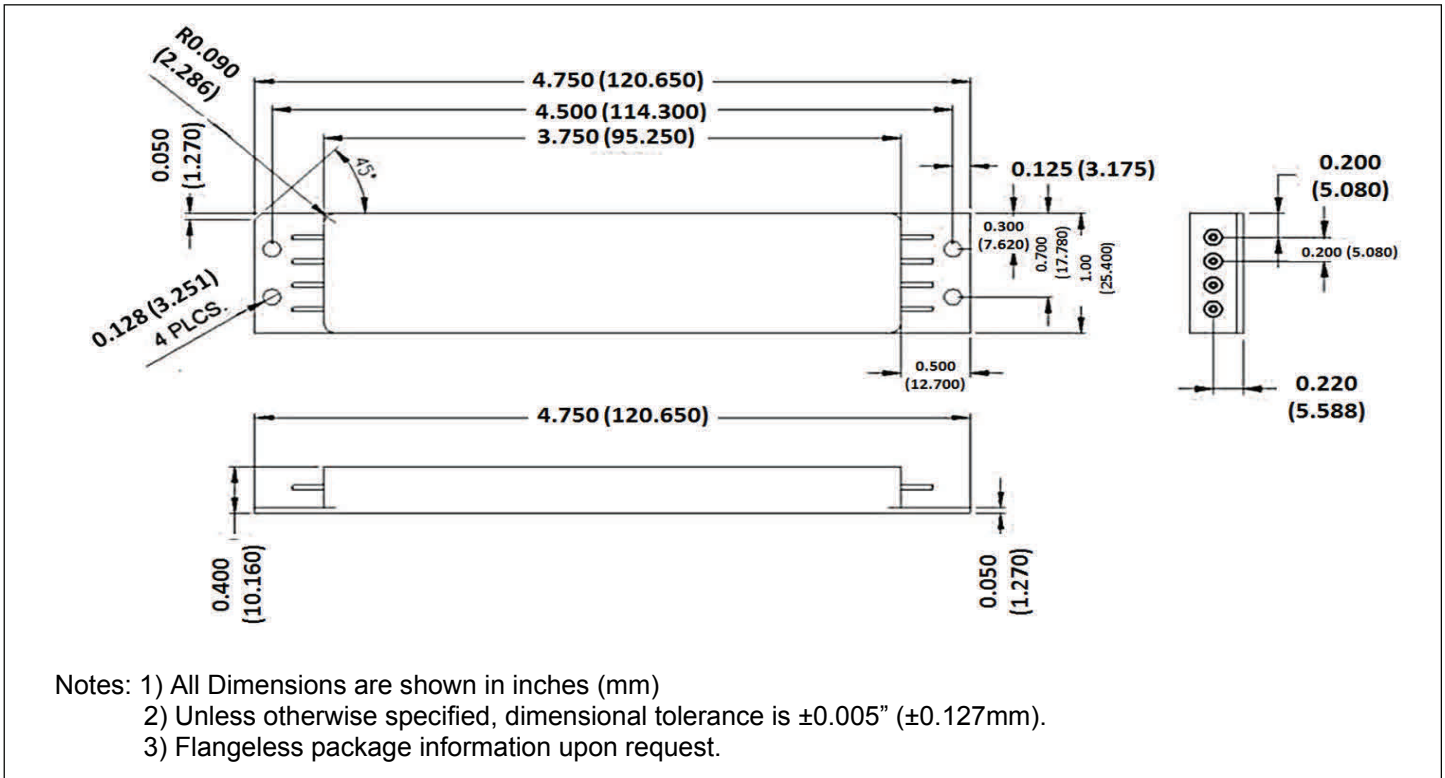

**Pinout:**



**Pin Designation Table**

Pin #	Description
1	INPUT +
2	INPUT RTN
3	INHIBIT / ENABLE
4	SYNC. IN
5	CHASSIS
6	TRIM
7	OUTPUT RTN
8	OUTPUT +

**Device Screening**

Requirement	MIL-STD-883 Method	Condition
Internal Visual	2017	Pre-seal Inspection
Seal (Parallel Seam) including Fine and Gross Leak Test	1014	
Temperature Cycling	1010	215°C to -35°C, 10 cycles
Constant Acceleration	2001	500g, 1 minute
PIND	2020	Test condition "A" , 20G Peak @ 40Hz
Burn-in	1015	215°C for 48 hours
External Visual	2009	

**Part Numbering**

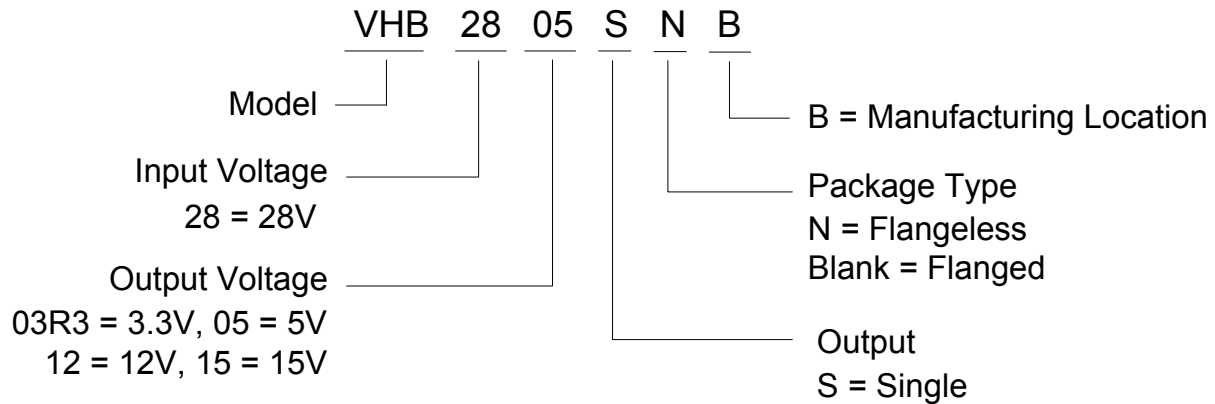

### **IMPORTANT NOTICE**

The information given in this document shall be in no event regarded as guarantee of conditions or characteristic. The data contained herein is a characterization of the component based on internal standards and is intended to demonstrate and provide guidance for typical part performance. It will require further evaluation, qualification and analysis to determine suitability in the application environment to confirm compliance to your system requirements.

With respect to any example hints or any typical values stated herein and/or any information regarding the application of the product, Infineon Technologies hereby disclaims any and all warranties and liabilities of any kind including without limitation warranties on non- infringement of intellectual property rights and any third party.

In addition, any information given in this document is subject to customer's compliance with its obligations stated in this document and any applicable legal requirements, norms and standards concerning customer's product and any use of the product of Infineon Technologies in customer's applications.

The data contained in this document is exclusively intended for technically trained staff. It is the responsibility of any customer's technical departments to evaluate the suitability of the product for the intended applications and the completeness of the product information given in this document with respect to applications.

For further information on the product, technology, delivery terms and conditions and prices, please contact your local sales representative or go to ([www.infineon.com/hirel](http://www.infineon.com/hirel)).

### **WARNING**

Due to technical requirements products may contain dangerous substances. For information on the types in question, please contact your nearest Infineon Technologies office.

单击下面可查看定价，库存，交付和生命周期等信息

[>>Infineon Technologies\(英飞凌\)](#)