

HIGH RELIABILITY DC-DC CONVERTER

165°C, 270V Input, 55W, 22V, Single Output

Description

The HTH27022S is a single output 55W DC-DC converter designed to operate in extremely high temperature environments such as those encountered in oil exploration. Features include small size, low weight and high tolerance to environmental stresses such as wide wide temperature extremes, severe shock and vibration. All internal components and assembly processes have been selected and developed to ensure reliable performance in the intended operating environments.

The converter incorporates a fixed frequency forward topology with magnetic feedback and internal EMI filter. It also includes an external inhibit port and have an adjustable output voltage. It is enclosed in a hermetic 4.0" x 2.15" x 0.40" (3.5"x1.5"x0.40"H excluding mounting tabs and I/O pins) AlSi package and weighs less than 70 grams. The package utilizes rugged ceramic feed-thru, copper-cored pins and is sealed using laser welding.

Full environmental screening includes temperature cycling, constant acceleration, fine and gross leak, and burn-in. Please refer to Device Screening table. Variations in electrical specifications and screening to meet custom requirements can be accommodated

Circuit Description

The HTH27022S converter utilizes an enhanced forward topology with two power switches and resonant reset. The nominal switching frequency is 520 kHz. Electrical isolation and tight output regulation are achieved through the use of a magnetically coupled feedback. Voltage feed-forward with duty factor limiting provides high line rejection and protection against output over voltage due to certain component failures in the internal control loop. This mechanism limits the maximum output voltage to approximately 20% over the nominal regardless of the line voltage with an output load that is $\geq 25\%$ of the full rated output power.

Output current is limited under load fault conditions to approximately 125% of the rating. An overload condition causes the converter output to behave like a constant current source with the output voltage dropping below nominal. The converter will resume normal operation when the load current is reduced below the current limit point. This protects the converter from both overload and short circuit conditions.

The current limit point exhibits a slightly negative temperature coefficient to reduce the possibility of thermal runaway.



Features

- 190 to 400V DC Input Range
- Up to 55W Output Power
- 22V, 2.5A Rated Output Voltage and Current
- Internal EMI Filter
- Magnetically Coupled Feedback
- 80% Minimum Efficiency
- 20°C to +165°C continuous with transient up to +175°C
- 100M Ω @ 500V DC Isolation
- Under-Voltage Lockout
- Short Circuit and Overload Protection
- Output Over Voltage Limiter
- Adjustable Output Voltage within 10% of nominal
- Synchronization Input and Output
- External Inhibit
- Low Weight, < 70grams

Applications

- Down Hole Exploration Tools

An external inhibit port (Pin 4) is provided to control converter operation. The converter's operation is inhibited when this pin is pulled low. It is designed to be driven by an open collector logic device. The pin may be left open for normal operation and has a nominal open circuit voltage of 4V with respect to the input return (Pin 2).

The output voltage of all models can be adjusted using a single external resistor within $\pm 10\%$ of nominal output voltage.

Specifications

Absolute Maximum Ratings		Recommended Operating Conditions	
Input Voltage range	-0.5V _{DC} to +400V _{DC}	Input Voltage range	190V _{DC} to 400V _{DC}
Output power	Internally limited	Output power	0 to Max. Rated
Lead Temperature	+300°C for 10 seconds	Operating temperature	-20°C to +165°C
Operating Case temperature	-20°C to +175°C	Storage temperature	-20°C to +165°C
Storage temperature	-55°C to +175°C		

Electrical Performance Characteristics

Parameter	Group A Subgroup	Conditions -20°C ≤ T _C ≤ +165°C V _{IN} = 270V DC ± 5%, C _L = 0 unless otherwise specified	Limits			Unit
			Min	Nom	Max	
Input Voltage	1,2,3	Guaranteed to turn on	190	270	400	V
Output Voltage (V _{OUT})	1,2,3	I _{OUT} = 100% rated load Note 1	21.34		22.66	V
Output Power (P _{OUT})	1,2,3	V _{IN} = 190, 270, 400 Volts, Note 2	0		55	W
Output Current (I _{OUT})	1,2,3	V _{IN} = 190, 270, 400 Volts, Note 2	0		2.5	A
Line Regulation (VR _{LINE})	1,2,3	V _{IN} = 190, 270, 400 Volts, Notes 1, 4 I _{OUT} = 10, 50, 100% Rated Load	-120		120	mV
Load Regulation (VR _{LOAD})	1,2,3	V _{IN} = 190, 270, 400 Volts, Notes 1, 4 I _{OUT} = 10, 50, 100% Rated Load	-220		220	mV
Input Current, No Load (I _{IN})	1,2,3	I _{OUT} = 0. Pin 4 open			15	mA
Input Ripple Current	1,2,3	I _{OUT} = 100% Rated Load, BW=10MHz			100	mAp-p
Input Current Inhibited	1,2,3	Pin 4 shorted to pin 2			5.0	mA
Input Under Voltage Lockout Turn-on (Input Voltage Rising)	1,3 2	Min Load, Note 1	160		180	V
Turn-off (Input Voltage Decreasing)	1,2,3		135		160	
Output Ripple (V _{RIP})	1,2,3	V _{IN} = 190, 270, 400 Volts, Notes 1, 3 I _{OUT} = 10%, 100% Rated Load			120	mVp-p
Efficiency (E _{FF})	1,2,3	I _{OUT} = 100% Rated Load , Note 1	80	84		%
Switching frequency (F _S)	1,2,3	Sync. Input (Pin 6) open	470		580	kHz
Synchronization Input Frequency Range	1,2,3	Notes 1, 12	500		600	kHz
Pulse Amplitude, High	1,2,3		4.0		10	V
Pulse Amplitude, Low	1,2,3		-0.5		0.8	V
Pulse Rise Time	1,2,3				100	ns
Pulse Duty Cycle	1,2,3			20		80

For Notes to Electrical Performance Characteristics Table, refer to page 4

Electrical Performance Characteristics (continued)

Parameter	Group A Subgroup	Conditions -20°C ≤ T _C ≤ +165°C V _{IN} = 270V DC ± 5%, C _L = 0 unless otherwise specified	Limits			Unit
			Min	Nom	Max	
Enable Input (Inhibit Function) Open Circuit Voltage Drive Current (Sink) Voltage Range	1,2,3	Note 1, 12	3.0 -0.5		5.0 100 50	V μA V
Current Limit Point Expressed as a percentage of Full Rated Output Power	1,2,3	V _{OUT} = 90% of Nominal	105		150	%
Power Dissipation, Load Fault (P _D)	1,2,3	Short Circuit, Overload Note 7			30	W
Load Transient Response Amplitude Recovery	4,5,6	Load Step, 50% to/from 100% Notes 1, 8	-1200		+1200 400	mV μs
Amplitude Recovery	4,5,6	Load Step, 10% to/from 50% Notes 1, 8	-1200		+1200 400	mV μs
Line Transient Response Amplitude Recovery	4,5,6	Input Voltage Step, 190V to/from 400V I _{OUT} = 100% rated load Notes 1, 9, 10	-500		+500 400	mV μs
Turn-on Response Overshoot (V _{OS}) Turn-on Delay (T _{DLY})	4,5,6	V _{in} = 190V, 270V, 400V I _{OUT} = 50% rated load Notes 1, 11	5.0		500 60	mV ms
Capacitive Load (C _L)	1	I _{OUT} = 100% rated load No effect on DC performance Notes 1, 5, 6, 12	1000			μF
Line Rejection	1	MIL-STD-461, CS101 30Hz to 50kHz, Note 1, 12	40	60		dB
Isolation	1	Input to Output or Any Pin to Case except pin 3, test @ 500V _{DC}	100			MΩ
Device Weight					70	g

For Notes to Electrical Performance Characteristics Table, refer to page 4

Notes for Electrical Performance Characteristics Table

1. Unless otherwise specified, "Rated" load is 55 watts, 2.5 Amps.
2. Parameter verified during line and load regulation tests.
3. Guaranteed for a D.C. to 20 MHz bandwidth. Tested using a 10 kHz to 10 MHz bandwidth.
4. Load is varied for output under test. Regulation relative to output voltage at 50% rated load.
5. Capacitive load may be any value from 0 to the maximum limit without compromising dc performance.
6. A capacitive load in excess of the maximum limit may interfere with the proper operation of the converter's overload protection, causing erratic behavior during turn-on.
7. Overload power dissipation is defined as the device power dissipation with the load set such that $V_{OUT} = 90\%$ of nominal.
8. Load step transition time $\geq 10\mu s$.
9. Recovery time is measured from initiation of the transient to where V_{OUT} has returned to within $\pm 1\%$ of steady state value.
10. Line step transition time $\geq 100\mu s$.
11. Turn-on delay time from either a step application of input power or a logic low to a logic high transition on the inhibit pin to the point where $V_{OUT} = 90\%$ of nominal.
12. Parameter is tested as part of design characterization or after design changes. Thereafter, parameter shall be guaranteed to the limits specified.

Fig 1. Circuit for Measuring Output Ripple Voltage

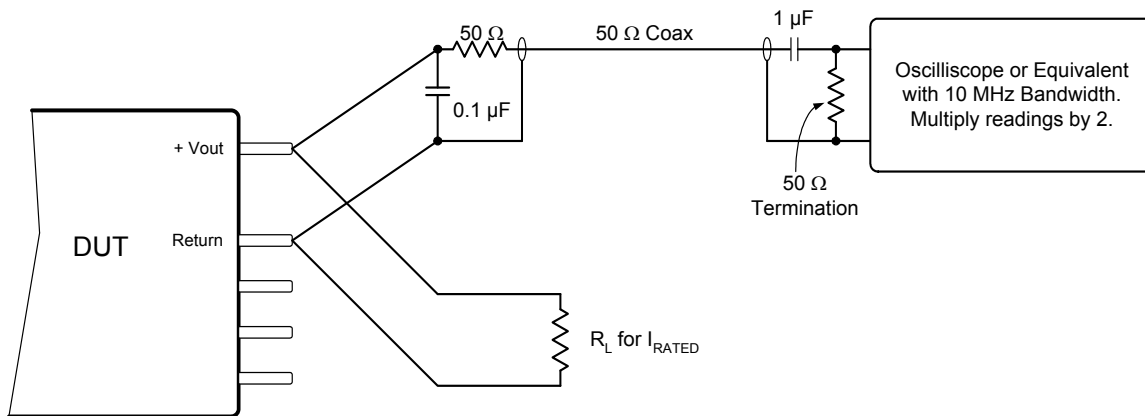

Typical Efficiency Curves

Fig 2: Efficiency vs Output Current at 25°C with Vin = 190V, 270V and 400V

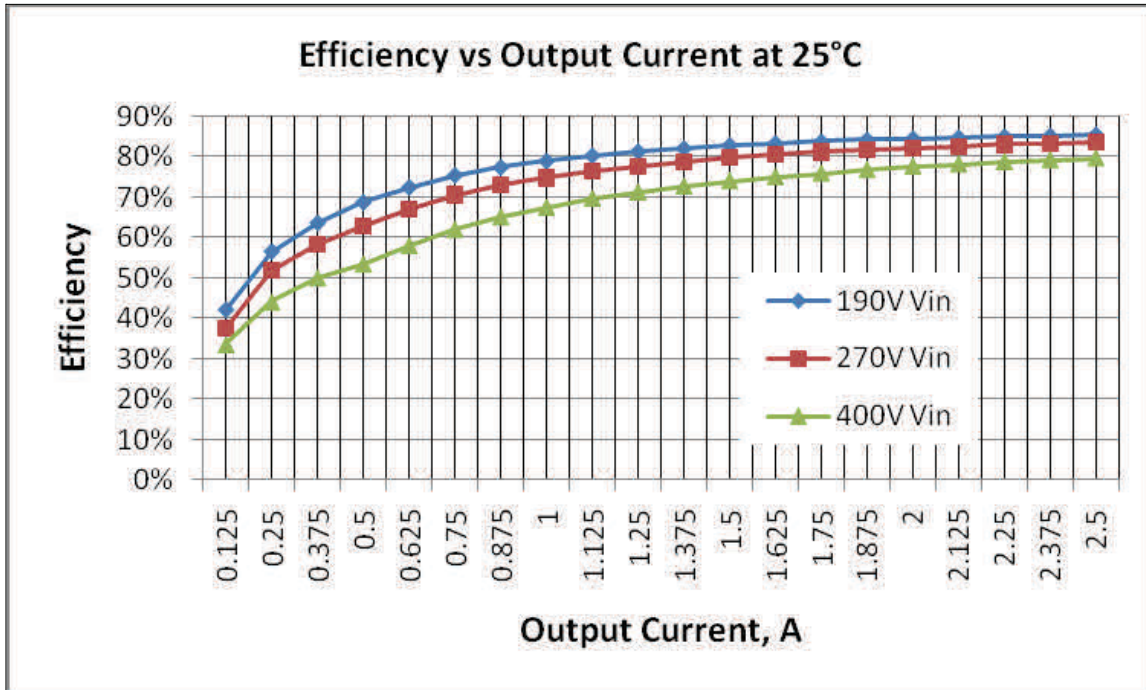

Fig 3: Efficiency vs Output Current at 165°C with Vin = 190V, 270V and 400V

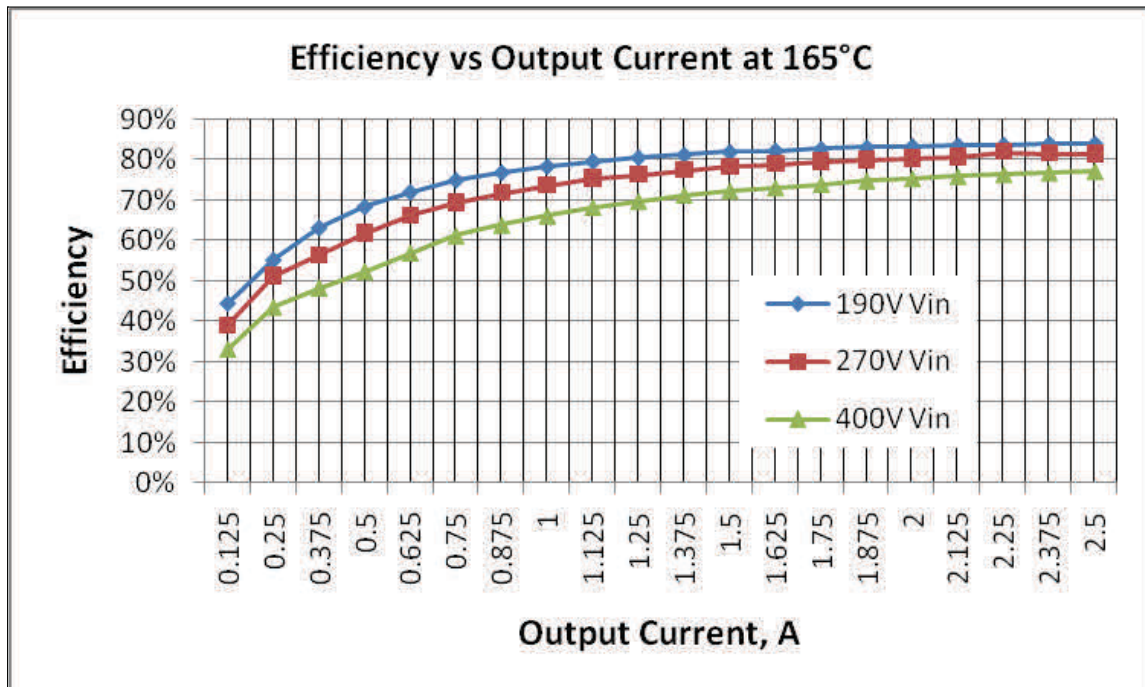
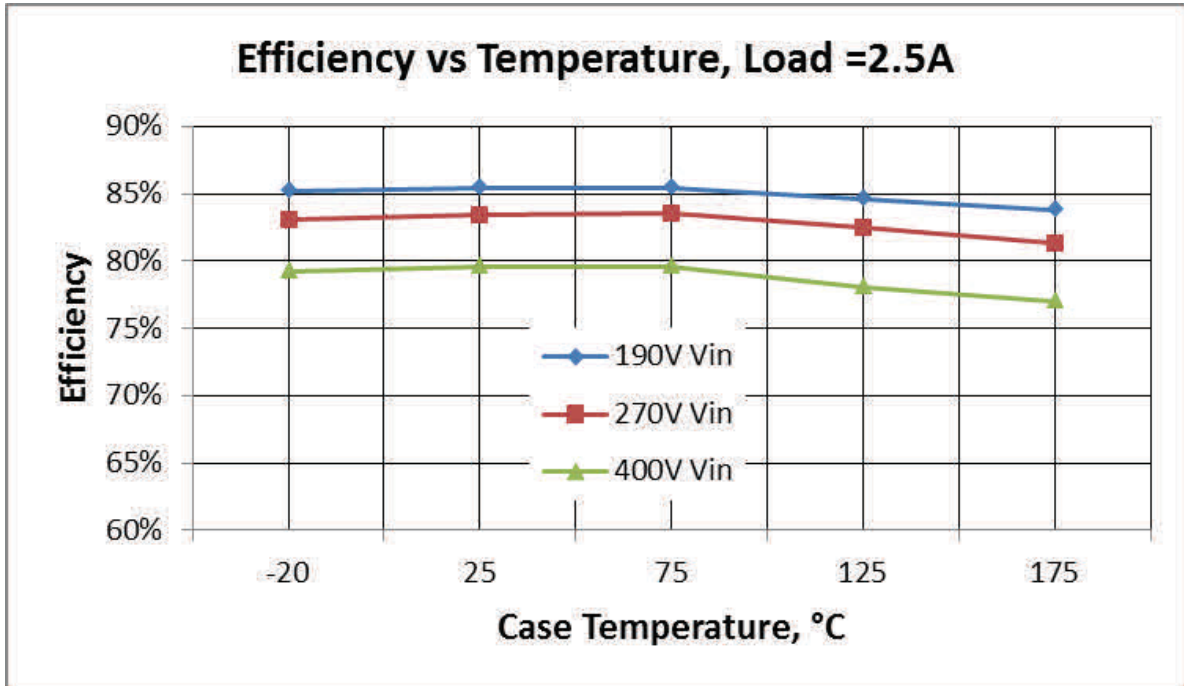

Fig 4: Efficiency vs Temperature, Load = 2.5A with Vin = 190V, 270V and 400V



Load Transient Waveforms

Fig 5: Load Transient at 25°C, Vin = 270V, Load = 0.25A to 1.25A, Ch2 = Vout

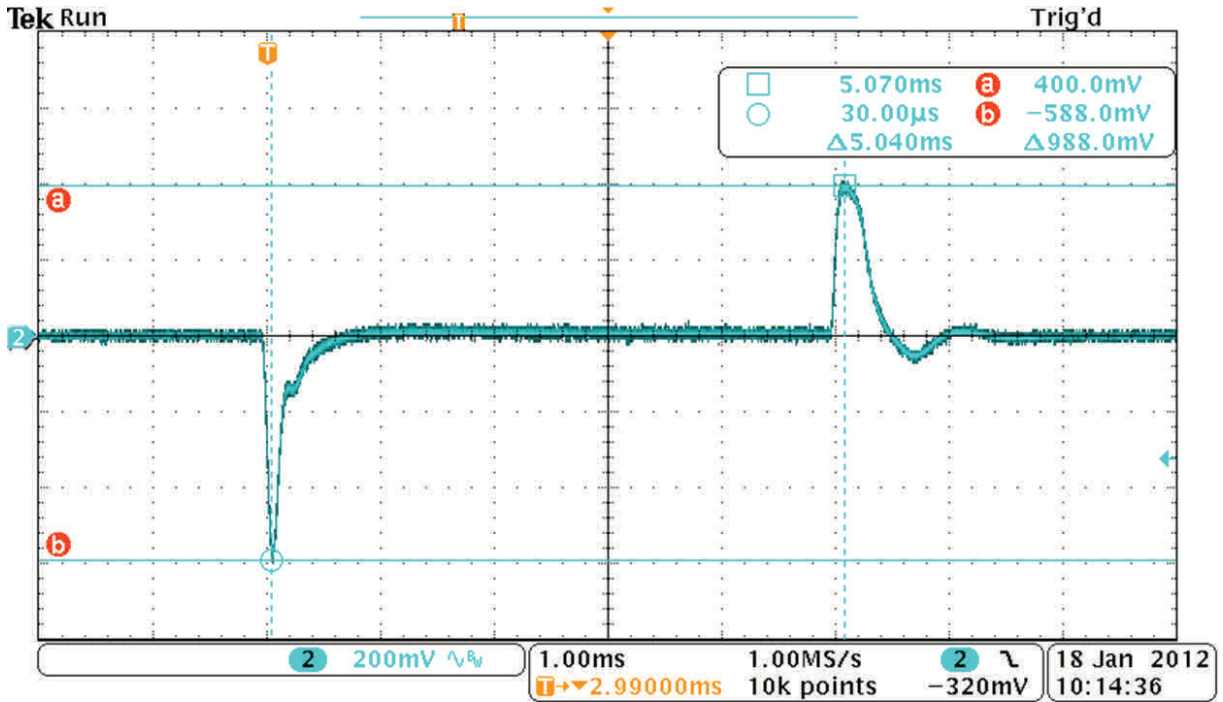

Fig 6 : Load Transient at 165°C, Vin = 270V, Load = 0.25A to 1.25A, Ch2 = Vout

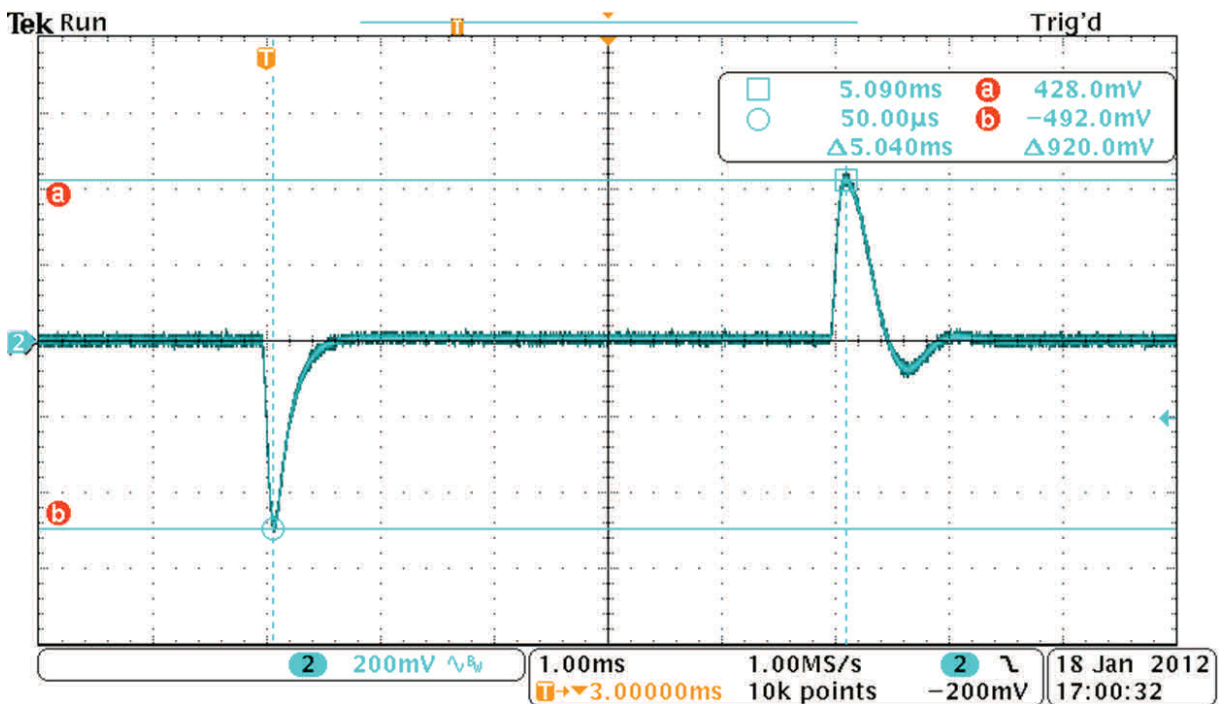

Fig 7: Load Transient at 25°C, Vin = 270V, Load = 1.25A to 2.5A, Ch2 = Vout

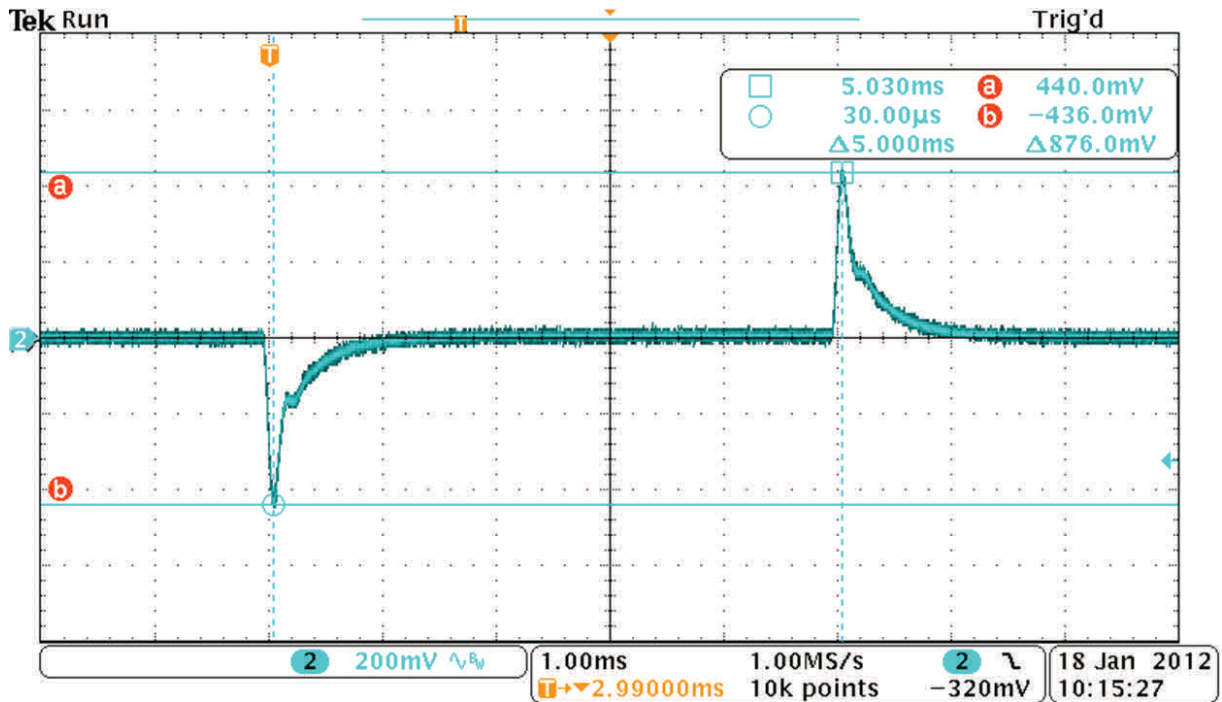
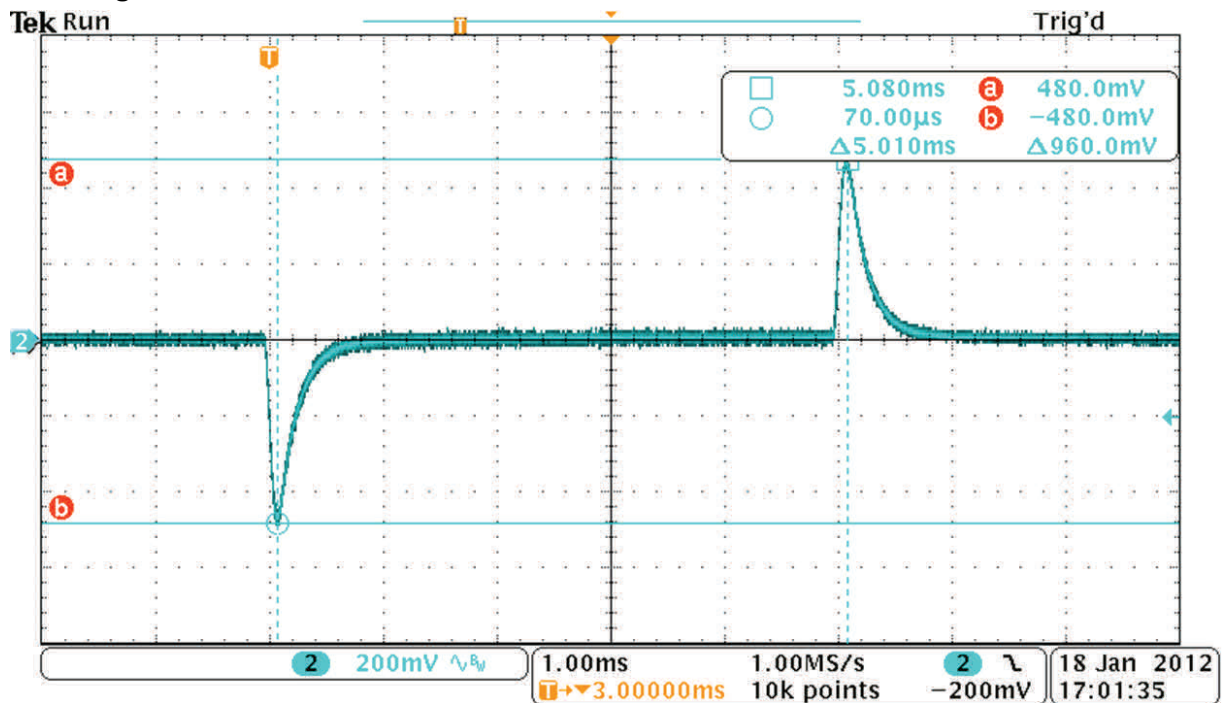

Fig 8 : Load Transient at 165°C, Vin = 270V, Load = 1.25A to 2.5A, Ch2 = Vout



Technical Notes

Remote Sensing

Connection of the + Sense and - Sense leads at a remotely located load permits compensation for resistive voltage drop between the converter output and the load when they are physically separated by a significant distance. This connection allows regulation at the point of application. To minimize noise pickup that could interfere normal operation of the converter, a twisted pair for remote sensing is highly recommended. When the remote sensing features is not used, the sense leads should be connected to their respective output terminals at the converter.

Notes:

- (1) If the +Sense connection is unintentionally broken, the converter has a fail-safe output voltage of $V_{out} + 25\text{mV}$, where the 25mV is independent of the nominal output voltage.
- (2) In the event of both the +Sense and -Sense connections being broken, the output will be limited to $V_{out} + 440\text{mV}$. This 440mV is also essentially constant independent of the nominal output voltage. While operation in this condition is not damaging to the device, not all performance parameters will be met.
- (3) The +Sense Pin shall be kept from being shorted to the -Sense Pin or the Output Return Pin through a resistance path $< 1\text{k}\Omega$, or permanent damages will occur inside the converter.

Inhibiting Converter Output

As an alternative to application and removal of the DC voltage to the input, the user can control the converter output by providing TTL compatible negative logic (LOW active) signal to Inhibit Pin (Pin 4) with respect to the Input Return Pin (Pin 2). The Inhibit Pin is internally pulled "high" so that when not used, an open connection on the Inhibit Pin permits normal converter operation. When its use is desired, a logical "low" on this port will shut the converter down.

Synchronization of Multiple Converters

When operating multiple converters, system requirements often may require operation of the converters at a common frequency. To accommodate this requirement, the converters provide both a synchronization input and output

The Sync Input port permits synchronization of a HT converter to any compatible external frequency source operating between 500 kHz and 600 kHz. This input signal should be referenced to the Input Return and has a 10% to 90% duty cycle. Compatibility requires transition times less than 100ns, maximum low level of +0.8V and a minimum high level of +2.0V. The Sync Output of a converter which has been designated as the master oscillator provides a convenient frequency source for this mode of operation. When external synchronization is not required, the Sync In Pin should be left unconnected thereby permitting the converter to operate at its own internally set frequency.

The sync output signal is a continuous pulse train factory-set at 520 ± 50 kHz, with a duty cycle of $15 \pm 5.0\%$. This signal is referenced to the Input Return and has been tailored to be compatible with the Sync Input port. Transition times are less than 100ns and the low level output impedance is less than 50Ω . This signal is active when the DC input voltage is within the specified operating range and the converter is not inhibited. This output has adequate drive capability to synchronize at least five additional converters.

Output Voltage Adjust - For Higher or Lower Output Voltage

In addition to permitting close voltage regulation of remotely located loads, the converter has a Vadj Pin allowing the users to trim its output voltage up or down for their applications. The adjustment range is limited to +10% , -20% maximum. The adjustments are intended as a means to “trim” the output to a voltage setting for certain design application, but are not intended to create a variable output converter. The output voltage is done by connecting a resistor with an appropriate value between the Vadj Pin and either +Sense and or -Sense Pins while as shown in Fig. 9 below. The resistance value for a desired output voltage can be determined by formulae described below.

Fig 9: Connection for VOUT Adjustment

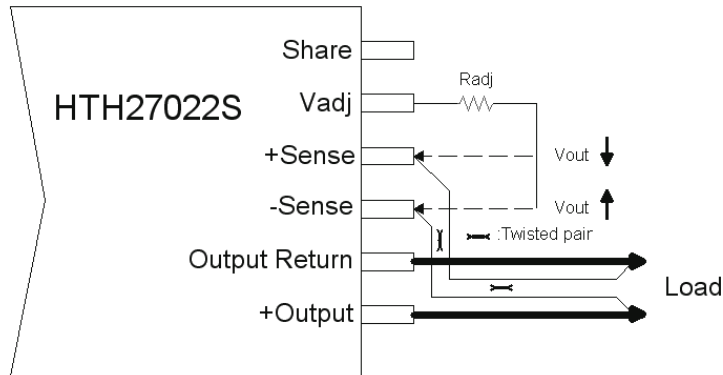

Voltage Trimming Procedure:

- (1) Nominal Output Voltage with **Vadj** Pin (Pin 11) Open: 22V
- (2) **Trimming Up** Output Voltage by installing a trimming resistor **Radj** (1/4W, 1%) between the **Vadj** Pin (Pin 11) and **-SENSE** Pin (Pin 9):

$$\mathbf{Radj} = [1950 / [10 * (Vout - 2.5) - 195]] - 50; \mathbf{Radj} \text{ in } k\Omega, \mathbf{Vout} \text{ in Volts}$$

Example: To trim Vout up to **24V**

$$\mathbf{Radj} = [1950 / [10 * (24 - 2.5) - 195]] - 50 = [1950 / 20] - 50 = 47.5 (k\Omega)$$

Thus, Vout can be trimmed up to **24V** by installing a 1/4W, 1%, 47.5kΩ resistor between the **Vadj** Pin (Pin 11) and the **-SENSE** Pin (Pin 9).

- (3) **Trimming Down** Output Voltage by installing a trimming resistor **Radj** (1/4W, 1%) between the **Vadj** Pin (Pin 11) and **+SENSE** Pin (Pin 10)

$$\mathbf{Radj} = [780 * (Vout - 2.5)] / [195 - 10 * (Vout - 2.5)]; \mathbf{Radj} \text{ in } k\Omega, \mathbf{Vout} \text{ in Volts}$$

Example: To trim Vout down to **20V**

$$\mathbf{Radj} = [780 * (20 - 2.5)] / [195 - 10 * (20 - 2.5)] = 13650 / 20 = 682.5 (k\Omega)$$

Thus, Vout can be trimmed down to **20V** by installing a 1/4W, 1% 682.5kΩ resistor between the **Vadj** Pin (Pin 11) and the **+SENSE** Pin (Pin 10)

Share Function - Paralleling Converters for Higher Output Current or Reliability Redundancy

The converter has a built-in OR-ing diode, rated 300V/10A and connected to the Share Pin as indicated in Fig 10. Multiple converters can be paralleled and configured as shown in Fig 10 for the following purposes:

- (1) Paralleling for higher output current: Several converters can be paralleled for sharing higher output current demand at the expense of some degradation in the load regulation.
- (2) N+1 Redundancy for fault tolerance and extra system reliability: When one of the paralleled converters fails with a lower output voltage or short, it will be isolated from the rest of the converters in parallel. The system can continue to function normally.

Note: Direct connection of the +Sense Pin to a remote load is not recommended due to potential control loop contention that could interfere the overall sharing stability or loss of fault isolation. Consult factory for additional application specific options.

Fig 10: Connection for Share Pin

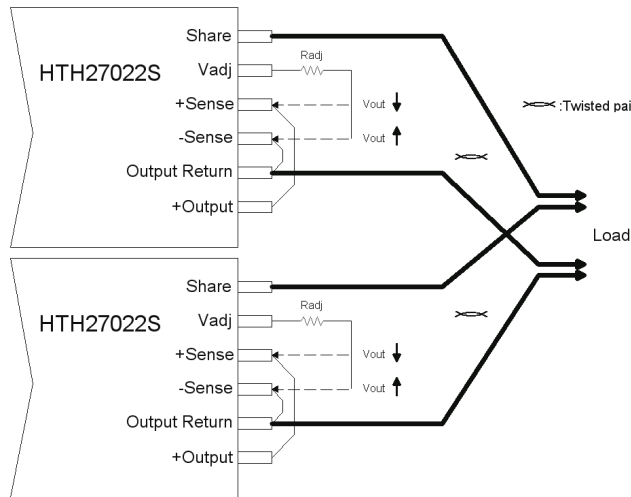

Mounting Procedure

DC-DC converters are constructed with aluminum-silicon (ALSi) controlled expansion alloy benefit from low mass, high thermal conductivity, and CTE match to substrates mounted in them. The one disadvantage over traditional cold rolled steel packages (CRS) however is that the ALSi material is more brittle than the CRS. For this reason, it is important to avoid using a thermal pad or gasket.

The DC-DC converter requires 6-32 size screws and #6 flat washers.

The minimum recommended mounting surface flatness is 0.002" per inch.

The Procedure for mounting the converter is as follows:

- 1. Check all surfaces for foreign material, burrs, or anything that may interfere with the different parts.
- 2. Place the converter on the mounting surface and line up with mounting holes.
- 3. Install screws using appropriate washers and tighten by hand (~ 4 in.oz) in the sequence shown below in the diagram
- 1. Tighten the screws with appropriate torque driver using a controlled torque of up to 20-24 in.lb in the sequence as shown in the diagram below.

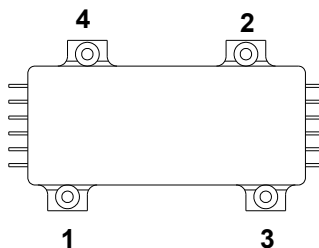
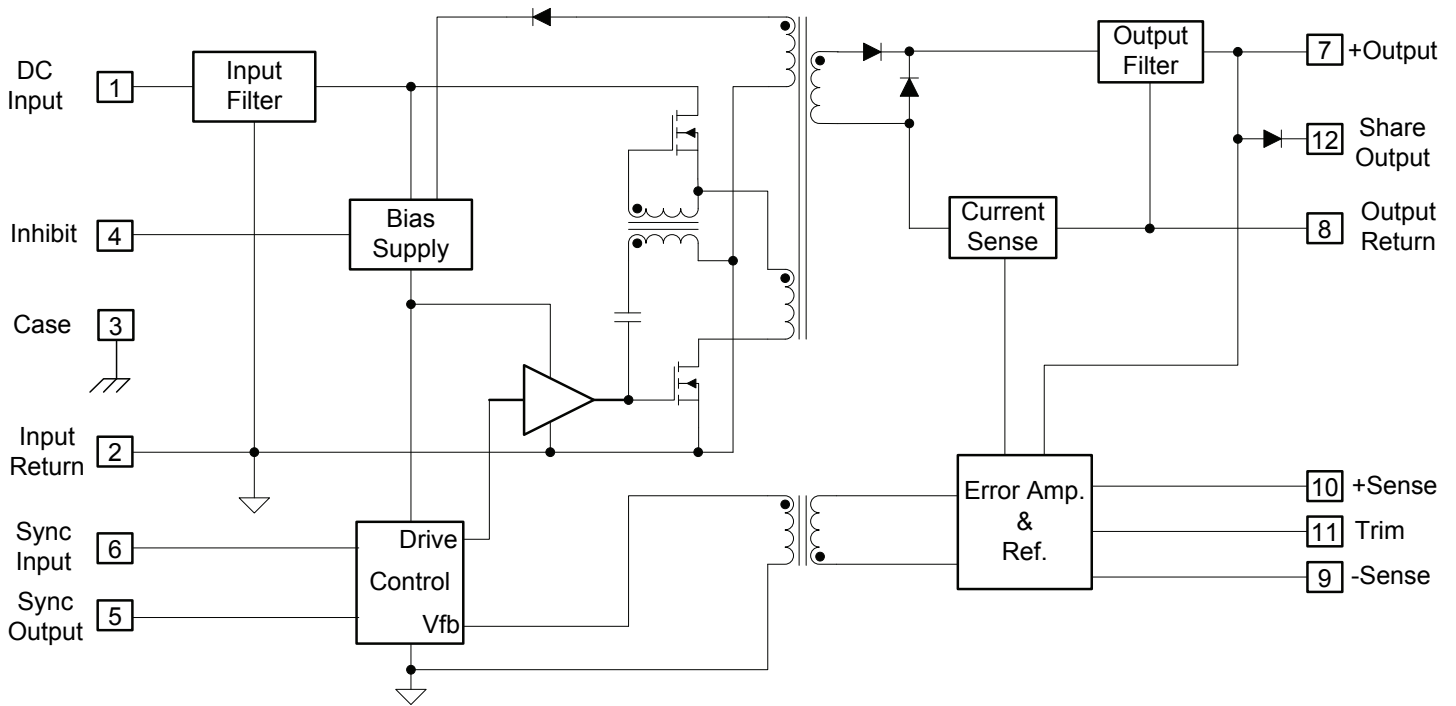

Fig 11 . Block Diagram



Pin Designation Table

Pin #	Description	Pin #	Description
1	DC Input	7	+ Output
2	Input Return	8	Output Return
3	Case	9	- Sense
4	Inhibit	10	+ Sense
5	Sync. Output	11	Trim
6	Sync. Input	12	Share Output

Mechanical Diagram

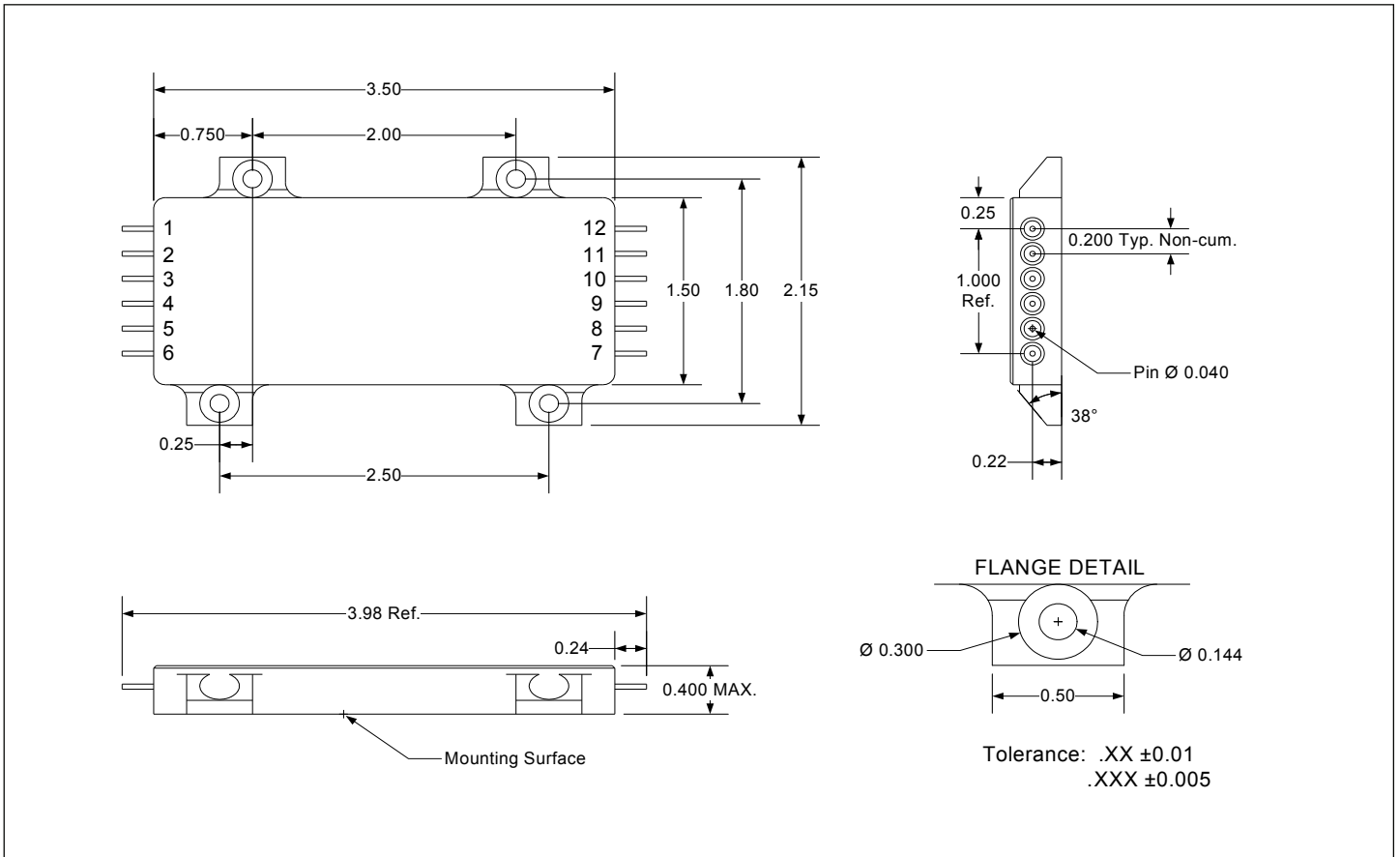

Device Screening

Requirement	MIL-STD-883 Method	Condition	No Suffix (Production Quality)	/EM suffix ① (For Engineering Evaluation)
Internal Visual	2017	-	X	X
Seal (Laser Weld)	1014	-	X	X
Fine Leak Test (Unpressurized)	-	-	X	X (For info only)
Gross Leak Test (Unpressurized)	-	-	X	X
Temperature Cycling	1010	-35°C, +165°C, 10 cycles	X	Not required
Electrical	In accordance with device specification	-	X	Not required
Constant Acceleration	2001	3000G for 1 minute	X	Not required
Burn-in	1015	48 hrs @ 165°C	X	8 hours @ 165°C
Final Electrical (Group A)	In accordance with device specification	-	X	X
Fine Leak Test	1014	A2	X	Not required
Gross Leak Test	1014	C1	X	X
External Visual	2009	-	X	X

Notes:

① Any Engineering Model (EM) build with the “EM” Suffix shall only be form, fit and functional equivalent to its Flight Model (FM) counterpart, and it may not meet the radiation performance. The EM Model shall not be expected comply with MIL-PRF-38534 flight quality/workmanship standards, and configuration control. An EM build may use electrical equivalent commercial grade components. IR HiRel will provide a list of non-compliance items upon request.

Part Numbering

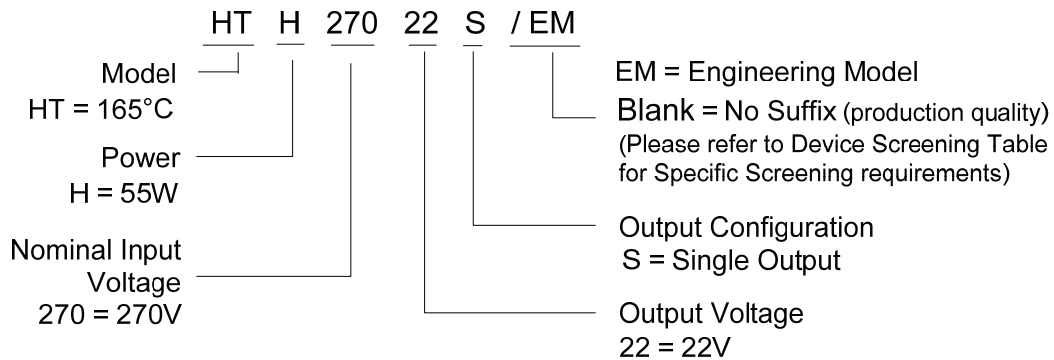

IMPORTANT NOTICE

The information given in this document shall be in no event regarded as guarantee of conditions or characteristic. The data contained herein is a characterization of the component based on internal standards and is intended to demonstrate and provide guidance for typical part performance. It will require further evaluation, qualification and analysis to determine suitability in the application environment to confirm compliance to your system requirements.

With respect to any example hints or any typical values stated herein and/or any information regarding the application of the product, Infineon Technologies hereby disclaims any and all warranties and liabilities of any kind including without limitation warranties on non- infringement of intellectual property rights and any third party.

In addition, any information given in this document is subject to customer's compliance with its obligations stated in this document and any applicable legal requirements, norms and standards concerning customer's product and any use of the product of Infineon Technologies in customer's applications.

The data contained in this document is exclusively intended for technically trained staff. It is the responsibility of any customer's technical departments to evaluate the suitability of the product for the intended applications and the completeness of the product information given in this document with respect to applications.

For further information on the product, technology, delivery terms and conditions and prices, please contact your local sales representative or go to (www.infineon.com/hirel).

WARNING

Due to technical requirements products may contain dangerous substances. For information on the types in question, please contact your nearest Infineon Technologies office.

单击下面可查看定价，库存，交付和生命周期等信息

[>>Infineon Technologies\(英飞凌\)](#)