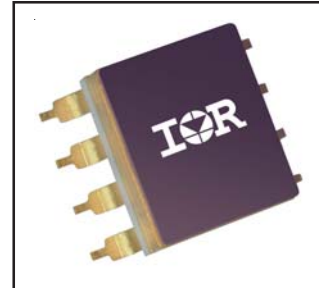


**Radiation Hardened, 100V,  
 Dual 1.0A, Solid State Relay**

**RDHA701CD10A2NX**

**Product Summary**

Part Number	Voltage	Current	Configuration	Rad Level
RDHA701CD10A2NX	100V	1.0A	Dual DC	100K



**Description**

The RDHA701CD10A2NX is a radiation hardened dual Solid State Relay in a hermetic package. It is configured as dual single pole single throw (SPST) normally open relay. This device is characterized for 100KRad (Si) total ionizing dose. The output MOSFET utilizes International Rectifier's R5 Technology.

**Features:**

- Total Dose Capability to 100KRad (Si)
- Optically Coupled
- 1000Vdc Input-to-Output, Channel-to-Channel, and Pin-to-Case Isolation
- Hermetically Sealed Ceramic Package

**Absolute Maximum Ratings @ T<sub>J</sub> = 25°C (unless otherwise specified)**

Parameter	Symbol	Value	Units
Output Withstand Voltage	V <sub>O(OFF)</sub>	100	V
Output Current ④	I <sub>O</sub>	1.0	A
Input Forward Current	I <sub>F</sub>	40	mA
Peak Input Forward Current (t ≤ 1.0ms)	I <sub>F(pk)</sub>	100	
Peak Input Reverse Voltage (t ≤ 1.0ms)	V <sub>R</sub>	5.0	V
Power Dissipation	P <sub>DISS</sub>	1.0	W
Operating Temperature Range	T <sub>J</sub>	-55 to +125	°C
Storage Temperature Range	T <sub>S</sub>	-65 to +150	
Lead Temperature (soldering ≤ 10sec)	TL	300	
Weight		0.8 (typ)	g

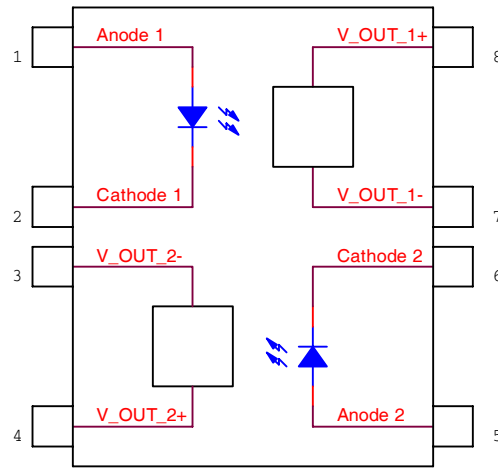
For notes, please refer to page 2

**Electrical Characteristics per Channel @  $-55^{\circ}\text{C} \leq T_C \leq +125^{\circ}\text{C}$  (Unless Otherwise Specified)**

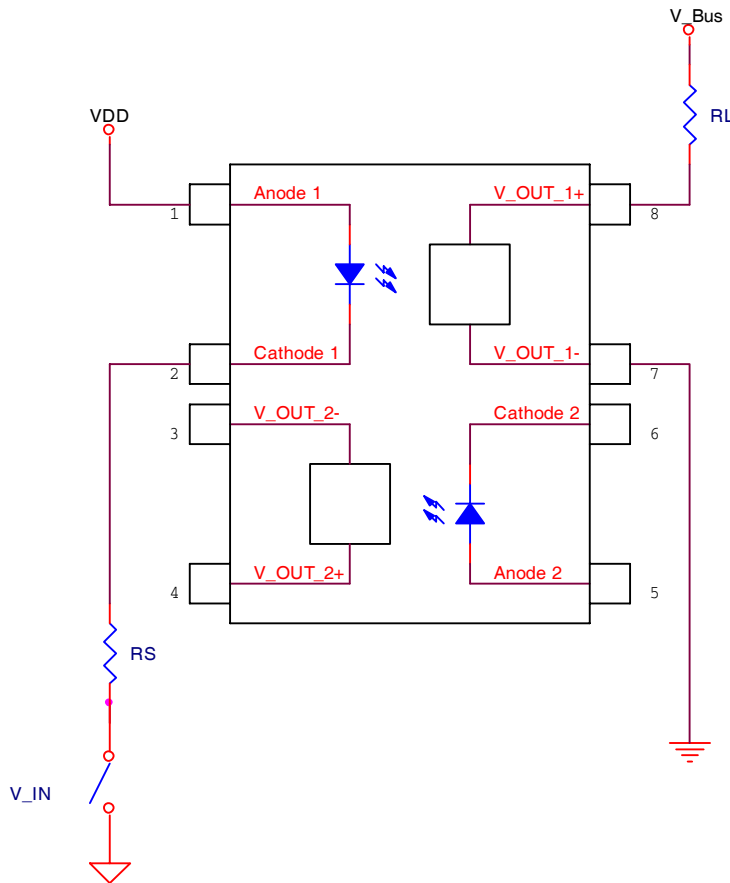
Parameter	Group A Subgroups	Test Conditions	Symbol	Min.	Typ.	Max.	Units
Output On-Resistance	1	$I_F = 10\text{mA}, I_O = 1.0\text{A}$	$R_{DS(ON)}$	--	0.25	0.40	$\Omega$
	2			--	0.39	0.80	
Output Leakage Current	1	$I_F = 0, V_{OUT} = 100\text{V}$	$I_O$	--	--	10	$\mu\text{A}$
	2			--	--	25	
Input Forward Voltage	1, 2, 3	$I_F = 10\text{mA}$	$V_F$	1.0	--	1.85	V
Input-to-Output Leakage Current	1	$V_{I-O} = 1000\text{Vdc}, \text{dwell} = 5\text{s}$	$I_{I-O}$	--	--	1.0	$\mu\text{A}$
Channel-to-Channel Leakage Current			$I_{CH-CH}$				
Pin-to-Case Leakage Current			$I_{CASE}$				
Turn-On Time ⑤⑥	9, 10, 11	$I_F = 0 \text{ to } 10\text{mA}, V_{BUS} = 28\text{V}, I_O = 1.0\text{A}, \text{Duty Cycle} \leq 1.0\%$	$t_{on}$	--	--	4.0	ms
Turn-Off Time ⑤⑥	9, 10, 11	$I_F = 10\text{mA to } 0, V_{BUS} = 28\text{V}, I_O = 1.0\text{A}, \text{Duty Cycle} \leq 1.0\%$	$t_{off}$	--	--	2.0	
Output Capacitance ①		$I_F = 0, V = +25\text{V}, f = 1\text{MHz}, T_C = 25^{\circ}\text{C}$	$C_{OSS}$	--	110	--	pF
Thermal Resistance ①		Per Channel	$R_{THJC}$	--	--	15	$^{\circ}\text{C/W}$
MTBF		MIL-HDBK-217F, SF@ $T_C = 25^{\circ}\text{C}$		22.7	--	--	MHrs

**Notes for Maximum Ratings and Electrical Characteristic Tables**

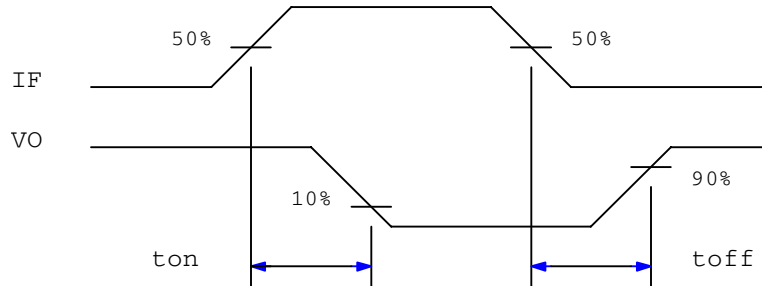
- ① Specification is guaranteed by design.
- ② Rise and fall times are controlled internally.
- ③ Optically coupled Solid State Relays (SSRs) have relatively slow turn-on and turn-off times. Care must be taken to insure that transient currents do not cause a violation of SOA. If transient conditions are present, IR recommends a complete simulation to be performed by the end user to ensure compliance with SOA requirements as specified in the IRHQ57110 data sheet.
- ④ While the SSR design meets the design requirements specified in MIL-PRF-38534, the end user is responsible for product derating, as applicable for the application.
- ⑤ Reference Fig. 2 for Switching Test Circuit and Fig. 3 for Switching Test Wave Form.
- ⑥ Turn-On Time ( $t_{on}$ ) includes the turn-on delay and rise time; Turn-Off Time ( $t_{off}$ ) includes the turn-off delay and fall time
- ⑦ International Rectifier does not currently have a DLA certified Radiation Hardness Assurance Plan.



**Fig 1: Block Diagram**

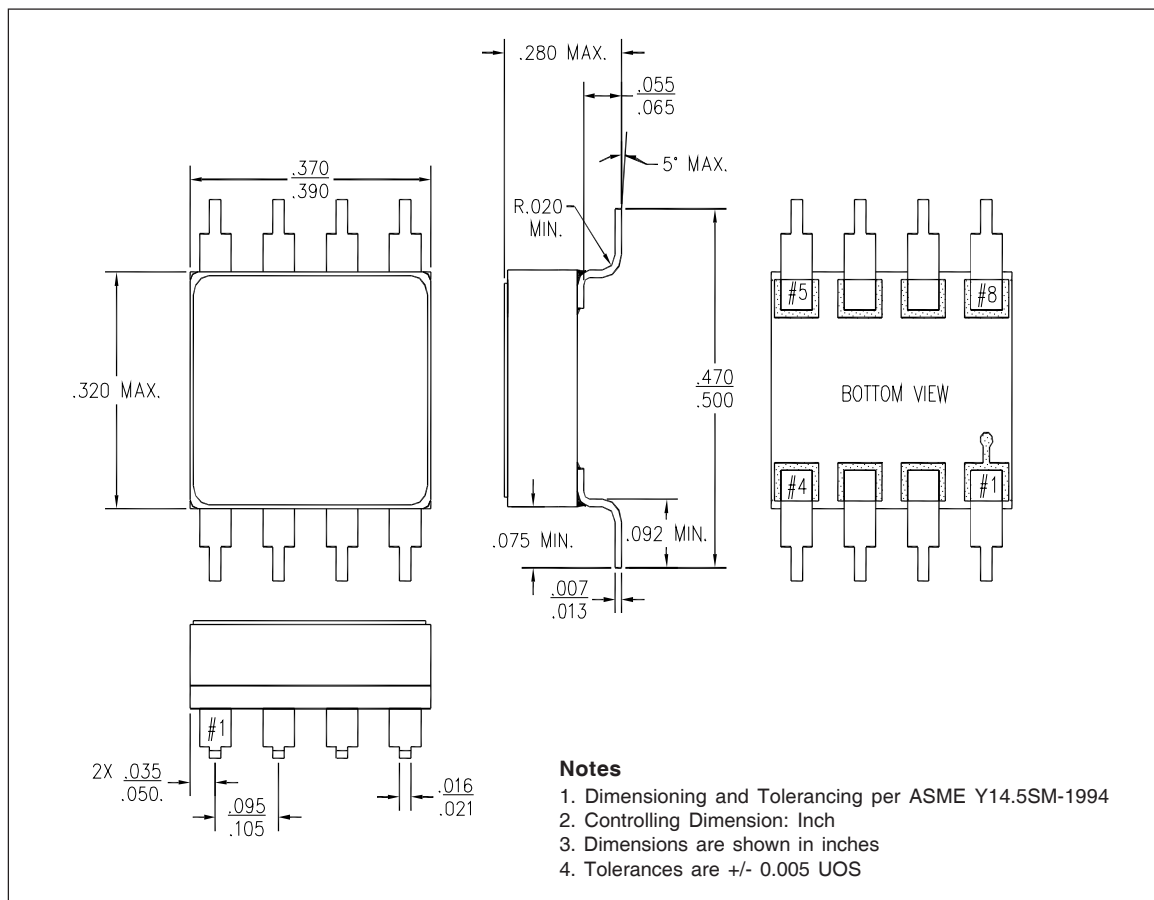


**Fig 2: Switching Test Circuit**

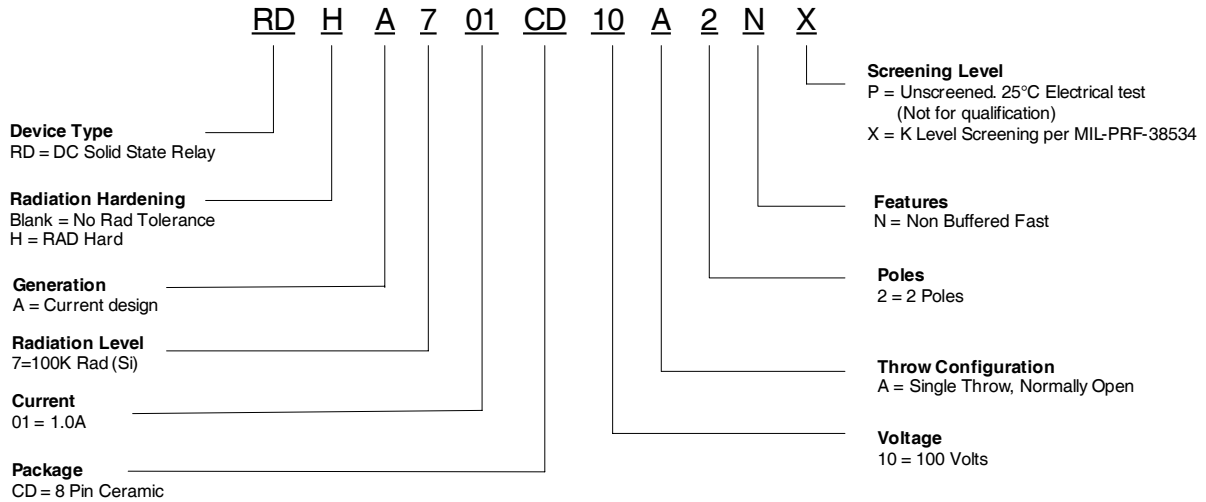


**Fig 3: Switching Test Waveform**

**Case Outline and Dimensions — Package (8 Pin Ceramic)**



**Part Numbering Nomenclature**



单击下面可查看定价，库存，交付和生命周期等信息

[>>Infineon Technologies\(英飞凌\)](#)