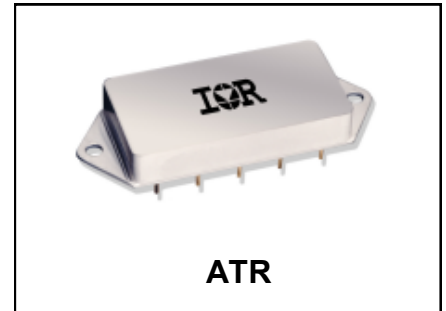

**HYBRID-HIGH RELIABILITY
DC-DC CONVERTER****28V Input, Triple Output****Description**

The ATR28XXT Series of DC-DC converters provide 30W of output power over the full military temperature range with no derating. These devices are pin compatible with the ATO series converters but offer twice the maximum output power in a lower profile package. A custom CMOS ASIC pulse width modulator operating at a nominal switching frequency of 550kHz combined with a unique magnetic feedback reduces circuit complexity for enhanced reliability. These converters provide 500V input to output isolation and operate in highly efficient single forward mode.

The advanced feedback design and high operating frequency provide an extremely wide bandwidth control loop with high gain and phase margin. This results in fast dynamic line and load response as well as superior audio rejection. The control loop is compensated to provide optimum performance over the full military temperature range and over the 16V to 40V input voltage range.

These converters are protected against both continuous output short circuits and output overload. Either load fault condition will result in operating in a low power dissipation fold back mode. The converters will shut down for approximately 15ms, then attempt to restart. This cycle will continue indefinitely unless the load fault is corrected. Recovery to normal operation is automatic upon removal of the load fault.

Manufactured in a facility fully qualified to MIL-PRF-38534, these converters are fabricated utilizing DLA Land and Maritime qualified processes. For available screening options, refer to device screening table in the data sheet. Variations in electrical, mechanical and screening specifications can be accommodated. Contact IR HiRel San Jose for special requirements.

Features

- 30W Output Power
- Flexible Output Loading
- -55°C to +125°C Operation
- Pin Compatible with ATO
- 0.410" Maximum Height
- 16V to 40VDC Input Range
- 500V Input to Output Isolation
- High Audio Rejection
- MIL-STD-704 Compatible
- Load Fault Protection - Short Circuit and Overload
- TTL level Compatible Synchronization
- Standard Microcircuit Drawings Available

Specifications

Absolute Maximum Ratings		
Input voltage range	-0.5V _{DC} to +50V _{DC}	
Power Output	Internally limited, 37.5W typical	
Lead temperature	300°C	
Soldering temperature	300°C for 10second	
Temperature Range ⁶	Operating case temperature	-55°C to +135°C
	Storage temperature	-65°C to +135°C

Static Characteristics T_{CASE} = -55°C to +125°C, V_{IN} = +28V ± 5 % unless otherwise specified.

Parameter	Symbol	Test Conditions -55°C ≤ T _C ≤ +125°C, V _{IN} = 28 V _{DC} ± 5%, C _L = 0, unless otherwise specified	ATR2812T		ATR2815T		Unit
			Min.	Max.	Min.	Max.	
Output voltage ¹	V _{OUT}	I _{OUT} = 0 (main) +25°C over temp. range I _{OUT} = 0 (dual) ¹ +25°C over temp. range	4.95 4.90 ±11.88 ±11.76	5.05 5.10 ±12.12 ±12.24	4.95 4.90 ±14.85 ±14.70	5.05 5.10 ±15.15 ±15.30	V _{DC}
Output current ^{1,2,3,4}	I _{OUT}	V _{IN} = 16, 28, and 40V _{DC} (main) V _{IN} = 16, 28, and 40V _{DC} (dual) ¹	100 0.0	4000 ±625	100 0.0	4000 ±500	mAdc
Output ripple voltage ^{1,5}	V _{RIP}	V _{IN} = 16, 28, and 40V _{DC} (dual) BW = 20Hz to 2MHz (main) V _{IN} = 16, 28, and 40 V _{DC} BW = 20Hz to 2MHz (dual)		60 40		60 40	mV _{p,p}
Line regulation ^{1,3}	VR _{LINE}	V _{IN} = 16, 28, and 40V _{DC} P _{OUT} = 0.5, 7.5, 15W (main) V _{IN} = 16, 28, and 40V _{DC} (dual) P _{OUT} = 1.2/1.5, 7.5 and 15W (dual)		±25 ±60		±25 ±75	mV
Load regulation ^{1,3}	VR _{LOAD}	V _{IN} = 16, 28, and 40V _{DC} P _{OUT} = 0.5, 7.5, 15W (main) V _{IN} = 16, 28, and 40 V _{DC} P _{OUT} = 1.2/1.5, 7.5, and 15W (dual)		±50 ±60		±50 ±75	mV
Input current	I _{IN}	I _{OUT} = 0, inhibit (pin 8) Tied to input return (pin 10) I _{OUT} = 0, inhibit (pin 8) = open		15 75		15 75	mA
Input ripple current ⁴	I _{RIP}	I _{OUT} = 3000mA (main) P _{OUT} = 15W (dual) BW = 20Hz to 2MHz		50		50	mA _{p,p}
Efficiency	E _{EFF}	I _{OUT} = 3000mA (main) +25°C P _{OUT} = 15W (dual) over temp. range	75 72		75 72		%
Isolation	I _{SO}	Input to output or any pin to case (except pin 8)	100		100		MΩ
Load fault power dissipation	P _D	Overload Short circuit		14 9.0		14 9.0	W
Switching frequency	F _S		500	600	500	600	kHz
SYNC frequency range	F _{SYNC}	50% load to/from 100% load no load to/from 50% load	500	700	500	700	kHz
Inhibit open circuit voltage	V _{OI}		9.0	13	9.0	13	V

For Notes to Specifications, refer to page 3

Static Characteristics (Continued) $T_{CASE} = -55^{\circ}\text{C}$ to $+125^{\circ}\text{C}$, $V_{IN} = +28\text{V} \pm 5\%$ unless otherwise specified.

Parameter	Symbol	Test Conditions $-55^{\circ}\text{C} \leq T_C \leq +125^{\circ}\text{C}$, $V_{IN} = 28 V_{DC} \pm 5\%$, $C_L=0$, unless otherwise specified	ATR2812T		ATR2815T		Unit
			Min.	Max.	Min.	Max.	
Output response to Step transient Load changes ⁷	$V_{O_{LOAD}}$	50% load to/from 100% load No load to/from 50% load	-500 -1000	+500 +1000	-500 -1000	+500 +1000	mVpk
Recovery time step Step transient Load changes ^{7,8}	$T_{T_{LOAD}}$	50% load to/from 100% load No load to 50% load 50% load to no load		200 5.0 10		200 5.0 10	μs ms ms
Output response to Transient step ⁹ Line changes ¹⁰	$V_{O_{LINE}}$	Input step 16 from/to $40V_{DC}$ $I_{OUT} = 3000\text{mA}$ (main) $P_{OUT} = 15\text{W}$ (dual)		± 1500		± 1500	mVpk
Recovery time ⁸ Transient step ⁹ Line changes ¹⁰	$T_{T_{LINE}}$	Input step 16 from/to $40V_{DC}$ $I_{OUT} = 3000\text{mA}$ (main) $P_{OUT} = 15\text{W}$ (dual)		10		10	ms
Turn on overshoot ¹	$V_{T_{onOS}}$	$I_{OUT} = 0$, and 3000mA (main) $P_{OUT} = 0$, 15W (dual)		1000		1000	mVpk
Turn on delay ^{1, 11}	T_{onD}	$I_{OUT} = 0$, and 3000mA (main) $P_{OUT} = 0$, 15W (dual)		25		25	ms
Load Fault Recovery ¹⁰	T_{RLF}			25		25	ms
Device weight				65		65	g

Notes to Specifications

1. Tested at each output.
2. Parameter guaranteed by line and load regulation tests.
3. Although operation with no load is permissible, light loading on the main (+5 volt) output may cause the output voltage of the auxiliary outputs (± 12 volt or ± 15 volt) to drop out of regulation. It is therefore recommended that at least 100mA or 20 percent of the output power, whichever is greater, be taken from the main (+5 volt) output and at least 50mA (or $1\pm 2V$: 1.2W, $\pm 15V$: 1.5W) of the output power is taken from the auxiliary ($\pm 12V$ or $\pm 15V$)
4. Total combined output power 30 watts.
5. Bandwidth guaranteed by design. Tested for 20kHz to 2MHz.
6. An overload is that condition with a load in excess of the rated load but less than that necessary to trigger the overload protection circuit and is the condition of maximum power dissipation.
7. Load step transition time between $2.0\mu\text{s}$ to $10\mu\text{s}$
8. Recovery time is measured from the initiation of the transient to where V_{OUT} has returned to within $\pm 1.0\%$ of V_{OUT} at 50% load.
9. Input step transition time between $2.0\mu\text{s}$ to $10\mu\text{s}$.
10. Parameter shall be tested as part of design characterization and after design or process changes. Thereafter parameters shall be guaranteed to the limits specified in the table.
11. Turn on delay time measurement is for either a step application of power at the input or the removal of a ground signal from the inhibit pin (pin 8) while power is applied to the input.

Block Diagram

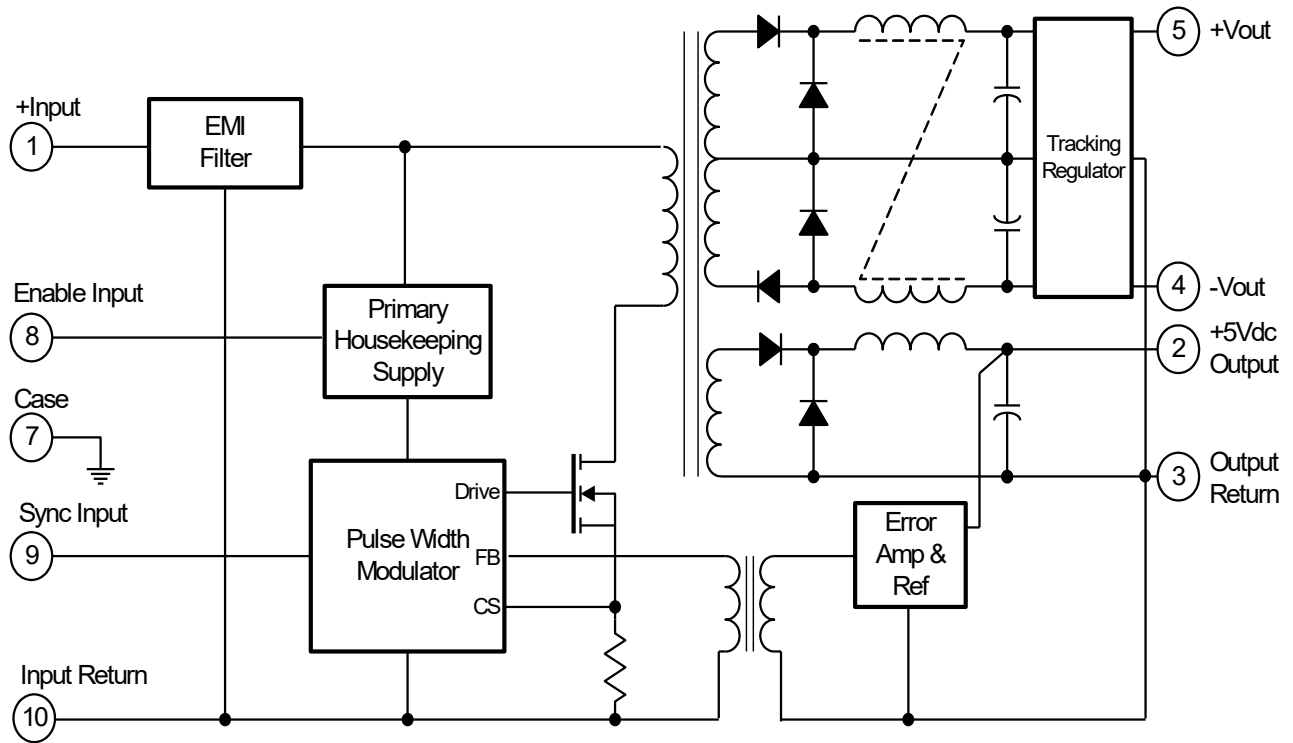

Standard Microcircuit Drawing Equivalence Table

Standard Microcircuit Drawing Number	Vendor Cage Code	IR HiRel Standard Part Number
5962-92159	52467	ATR2815T
5962-93158	52467	ATR2812T

Mechanical Outline

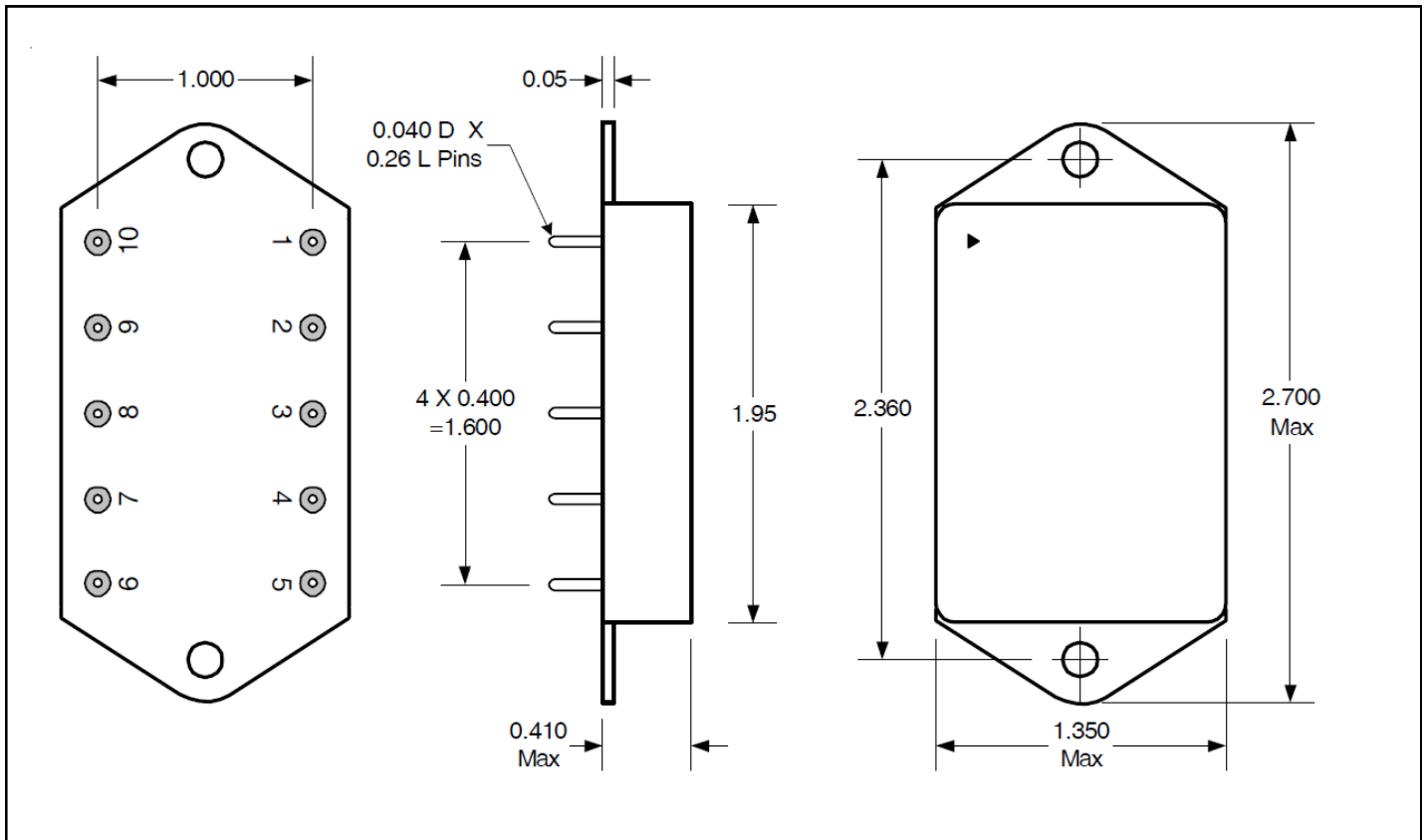

Pin Designation

Pin #	Designation
1	+ Input
2	+5V _{DC} Output
3	Output Return
4	- Dual Output
5	+ Dual Output
6	NC
7	Case Ground
8	Enable Input
9	Sync Input
10	Input Return

Device Screening

Requirement	MIL-STD-883 Method	No Suffix	ES ^②	HB	CH
Temperature Range	—	-55°C to +85°C	-55°C to +125°C ^③	-55°C to +125°C	-55°C to +125°C
Element Evaluation	MIL-PRF-38534	N/A	N/A	N/A	Class H
Non-Destructive Bond Pull	2023	N/A	N/A	N/A	N/A
Internal Visual	2017	①	Yes	Yes	Yes
Temperature Cycle	1010	N/A	Cond B	Cond C	Cond C
Constant Acceleration	2001, Y1 Axis	N/A	500 Gs	3000 Gs	3000 Gs
PIND	2020	N/A	N/A	N/A	N/A
Burn-In	1015	N/A	48 hrs @ hi temp	160 hrs @ 125°C	160 hrs @125°C
Final Electrical (Group A)	MIL-PRF-38534 & Specification	25°C	25°C ^②	-55°C, +25°C, +125°C	-55°C, +25°C, +125°C
PDA	MIL-PRF-38534	N/A	N/A	N/A	10%
Seal, Fine and Gross	1014	Cond A	Cond A, C	Cond A, C	Cond A, C
Radiographic	2012	N/A	N/A	N/A	N/A
External Visual	2009	①	Yes	Yes	Yes

Notes:

- ① Best commercial practice.
- ② Sample tests at low and high temperatures
- ③ -55°C to +105°C for AHE, ATO, ATW

Part Numbering

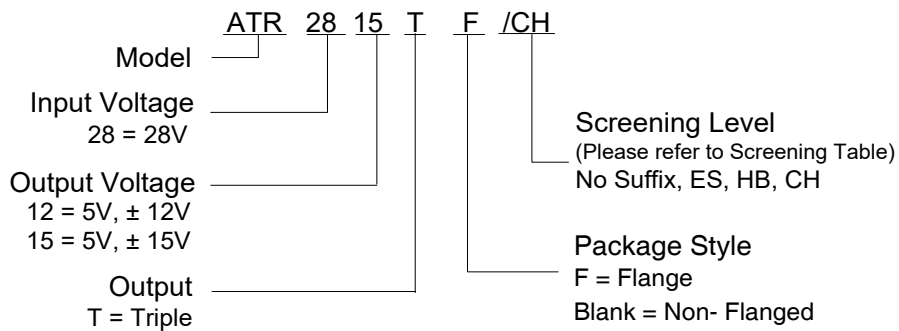

IMPORTANT NOTICE

The information given in this document shall be in no event regarded as guarantee of conditions or characteristic. The data contained herein is a characterization of the component based on internal standards and is intended to demonstrate and provide guidance for typical part performance. It will require further evaluation, qualification and analysis to determine suitability in the application environment to confirm compliance to your system requirements.

With respect to any example hints or any typical values stated herein and/or any information regarding the application of the product, Infineon Technologies hereby disclaims any and all warranties and liabilities of any kind including without limitation warranties on non- infringement of intellectual property rights and any third party.

In addition, any information given in this document is subject to customer's compliance with its obligations stated in this document and any applicable legal requirements, norms and standards concerning customer's product and any use of the product of Infineon Technologies in customer's applications.

The data contained in this document is exclusively intended for technically trained staff. It is the responsibility of any customer's technical departments to evaluate the suitability of the product for the intended applications and the completeness of the product information given in this document with respect to applications.

For further information on the product, technology, delivery terms and conditions and prices, please contact your local sales representative or go to (www.infineon.com/hirel).

WARNING

Due to technical requirements products may contain dangerous substances. For information on the types in question, please contact your nearest Infineon Technologies office.

单击下面可查看定价，库存，交付和生命周期等信息

[>>Infineon Technologies\(英飞凌\)](#)