

# Data Sheet

## iMOTION™ motor control IC for single motor drive

### Quality Requirement Category: Industry

#### Features

- Ready-to-use solution for high efficiency variable speed drives
- Pre-programmed motion control engine (MCE)
- Sensor less field oriented control (FOC) of permanent magnet synchronous motors (PMSM)
- Support for up to 31 sets of motor parameters
- Current measurement based on single or leg shunt
- Integrated oscillator, A/D converter, OP amps & comparators
- Integrated protection features
- Package: 5x5mm<sup>2</sup> QFN-32

#### Applications

- Pumps & fans
- Drones, multicopters
- Home appliances
- Any other PMSM drive

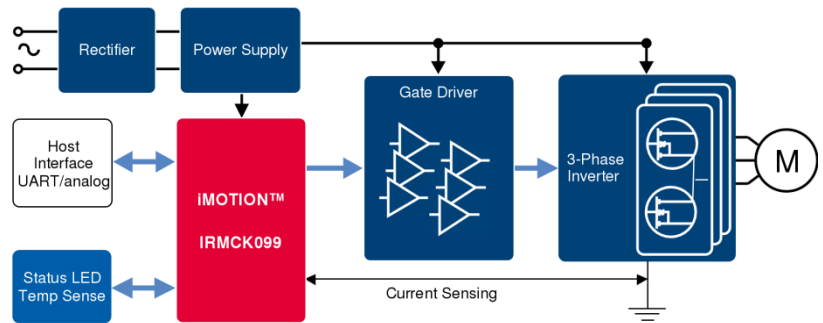

#### Description

The IRMCK099 combines the iMOTION™ motor control engine (MCE) with all peripherals required to realize a complete variable speed drive. The IRMCK099 does not require algorithm programming and can be used in combination with a  $\mu$ IPM™ or a discrete power stage.

The MCE implements sensor less field oriented control using single or leg shunt current feedback and uses space vector PWM with sinusoidal signals to provide highest energy efficiency.

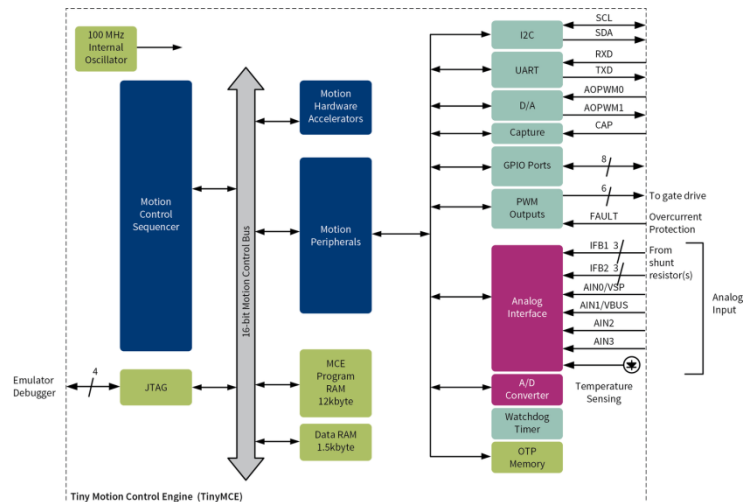



## High Performance Sensorless Motor Control IC

### Description

IRMCK099 is a low cost, high performance OTP memory based motion control ASIC designed primarily for appliance applications. IRMCK099 is designed to implement high performance control solutions for advanced inverterized appliance motor control. IRMCK099 contains the flexible Tiny Motion Control Engine (TinyMCE) for sensorless control of permanent magnet motors over the full speed range. The TinyMCE implements sensorless Field Oriented Control using single or leg shunt current feedback by a combination of hardware and IR-supplied firmware elements. Key components of the complex sensorless control algorithms, such as the Angle Estimator, are provided as complete pre-defined control blocks. The ASIC is designed to eliminate external components and reduce cost by including an A/D converter, analog amplifiers, an overcurrent comparator, watchdog timer and internal oscillator. Strong startup and configuration tools get the motor running quickly without any programming. A standby power mode can help to increase overall system efficiency. IRMCK099 comes in a 5mmx5mm, 32 pin QFN package.

### Features

- TinyMCE (Tiny Motion Control Engine) - Dedicated computation engine for high efficiency sinusoidal sensorless motor control
- Internal Oscillator – no clock required
- Built-in hardware peripheral for single or two shunt current feedback reconstruction and analog circuits
- Supports both interior and surface permanent magnet motor sensorless control
- Loss minimization Space Vector PWM
- Internal ITRIP comparator
- Two-channel analog output (Sigma Delta D/A)
- JTAG programming port for debugging
- UART and I2C serial interface
- Factory Calibrated Analog Inputs
- Capture input
- Watchdog timer with independent internal clock
- Standby low power mode
- Internal 16 Kbyte OTP memory
- CRC Memory Check
- 3.3V single supply

### Product Summary

Internal clock frequency (SYSCLK)	100MHz
MCE™ computation time	1 SYSCLK
MCE™ computation data range	16 bit signed
OTP Memory	16KB
MCE Data RAM	1.5KB
MCE Program RAM	12KB
FAULT latency (digital filtered)	2 µsec
PWM carrier frequency	1 – 20kHz
A/D input channels	6
A/D converter resolution	12 bits
A/D converter conversion speed	2 µsec
Analog output (PWM) resolution	8 bits
UART baud rate (typ)	57.6 Kbps
Number of digital I/O (max)	8
Package (lead free)	QFN 5x5 32L
Typical 3.3V operating current	< 30mA
Standby mode power consumption	3.5mW
Integrated Temperature Sensor(typ)	±5degC

Base Part Number	Package Type	Standard Pack		Orderable Part Number
		Form	Quantity	
IRMCK099M	QFN32	Tape and Reel	3000	IRMCK099MTR
		Tray	2450	IRMCK099M

## Table of Contents

<b>1</b>	<b>OVERVIEW</b> .....	<b>5</b>
<b>2</b>	<b>PINOUT</b> .....	<b>6</b>
<b>3</b>	<b>IRMCK099 BLOCK DIAGRAM AND MAIN FUNCTIONS</b> .....	<b>8</b>
<b>4</b>	<b>APPLICATION CONNECTION AND PIN FUNCTION</b> .....	<b>9</b>
4.1	MCE PERIPHERAL INTERFACE GROUP .....	9
4.2	MOTION PERIPHERAL INTERFACE GROUP .....	10
4.3	ANALOG INTERFACE GROUP .....	10
4.4	POWER INTERFACE GROUP .....	11
4.5	TEST INTERFACE GROUP .....	11
<b>5</b>	<b>DC CHARACTERISTICS</b> .....	<b>12</b>
5.1	ABSOLUTE MAXIMUM RATINGS .....	12
5.2	SYSTEM CLOCK FREQUENCY AND POWER CONSUMPTION .....	12
5.3	DIGITAL I/O DC CHARACTERISTICS .....	13
5.4	ANALOG I/O DC CHARACTERISTICS .....	14
5.5	A/D ACCURACY AND LINEARITY .....	14
5.6	UNDER VOLTAGE LOCKOUT DC CHARACTERISTICS .....	15
5.7	ITRIP COMPARATOR DC CHARACTERISTICS .....	15
5.8	WAKE-UP THRESHOLD DC CHARACTERISTICS .....	15
5.9	INTEGRATED TEMPERATURE SENSOR .....	15
<b>6</b>	<b>AC CHARACTERISTICS</b> .....	<b>16</b>
6.1	INTERNAL OSCILLATOR AC CHARACTERISTICS .....	16
6.2	ANALOG TO DIGITAL CONVERTER AC CHARACTERISTICS .....	16
6.3	OP AMP AC CHARACTERISTICS .....	17
6.4	SYNC TO SVPWM AND A/D CONVERSION AC TIMING .....	18
6.5	FAULT TO SVPWM AC TIMING .....	19
6.6	ITRIP AC TIMING .....	19
6.7	I <sup>2</sup> C AC TIMING .....	20
6.8	UART AC TIMING .....	21
6.9	CAPTURE INPUT AC TIMING .....	22
6.10	JTAG AC TIMING .....	23
<b>7</b>	<b>I/O STRUCTURE</b> .....	<b>24</b>
<b>8</b>	<b>PIN LIST</b> .....	<b>26</b>
<b>9</b>	<b>PACKAGE DIMENSIONS</b> .....	<b>27</b>
<b>10</b>	<b>PART MARKING INFORMATION</b> .....	<b>28</b>
<b>11</b>	<b>QUALIFICATION INFORMATION</b> .....	<b>28</b>

## List of Tables

TABLE 1 REMAP FUNCTIONS AVAILABLE ON GPIO.....	7
TABLE 2. ABSOLUTE MAXIMUM RATINGS.....	12
TABLE 3. SYSTEM CLOCK FREQUENCY AND POWER CONSUMPTION.....	12
TABLE 4. DIGITAL I/O DC CHARACTERISTICS .....	13
TABLE 5. ANALOG I/O DC CHARACTERISTICS.....	14
TABLE 6. UVCC 3.3V DC CHARACTERISTICS .....	15
TABLE 7. ITRIP DC CHARACTERISTICS .....	15
TABLE 8. WAKE-UP THRESHOLD DC CHARACTERISTICS .....	15
TABLE 9. INTERNAL OSCILLATOR AC CHARACTERISTICS .....	16
TABLE 10.A/D CONVERTER AC CHARACTERISTICS .....	16
TABLE 11 CURRENT SENSING OP AMP AC CHARACTERISTICS.....	17
TABLE 12. SYNC AC CHARACTERISTICS .....	18
TABLE 13. FAULT TO SVPWM AC TIMING.....	19
TABLE 14. ITRIP AC TIMING .....	19
TABLE 15. I <sup>2</sup> C AC TIMING .....	20
TABLE 16. UART AC TIMING.....	21
TABLE 17. CAPTURE AC TIMING .....	22
TABLE 18. JTAG AC TIMING .....	23
TABLE 19. PIN LIST .....	26

## List of Figures

FIGURE 1. TYPICAL APPLICATION BLOCK DIAGRAM USING IRMCK099 .....	5
FIGURE 2. PINOUT OF IRMCK099 .....	6
FIGURE 3. IRMCK099 BLOCK DIAGRAM.....	8
FIGURE 4. IRMCK099 LEG SHUNT CONNECTION DIAGRAM.....	9
FIGURE 5. VOLTAGE DROOP AND S/H HOLD TIME .....	16
FIGURE 6. OP AMP OUTPUT CAPACITOR .....	17
FIGURE 7. SYNC TIMING.....	18
FIGURE 8. FAULT TIMING.....	19
FIGURE 9. ITRIP TIMING .....	19
FIGURE 10. I <sup>2</sup> C TIMING .....	20
FIGURE 11. UART TIMING.....	21
FIGURE 12. CAPTURE TIMING .....	22
FIGURE 13. JTAG TIMING .....	23
FIGURE 14. DIGITAL I/O STRUCTURE .....	24
FIGURE 15. ANALOG I/O STRUCTURE .....	24
FIGURE 16. ANALOG ANALOG INPUT STRUCTURE FOR AIN0/STBY.....	24
FIGURE 17. VSS PIN I/O STRUCTURE.....	25
FIGURE 18. VDDCAP PIN I/O STRUCTURE.....	25
FIGURE 19. VDD1 PIN I/O STRUCTURE.....	25

## 1 Overview

IRMCK099 is a new generation International Rectifier integrated circuit device primarily designed as a one-chip solution for inverterized appliance motor control applications. Unlike a traditional microcontroller or DSP, the IRMCK099 provides a built-in closed loop sensorless control algorithm using the unique flexible Tiny Motion Control Engine (TinyMCE) for permanent magnet motors. The MCE™ consists of a collection of control elements, motion peripherals, a dedicated motion control sequencer and internal memory to map internal signal nodes. IRMCK099 also employs a unique single shunt current reconstruction circuit in addition to two leg shunt current sensing circuit to eliminate additional analog/digital circuitry. Integrated op-amps and A/D converter enable a direct shunt resistor interface to the IC. Four analog inputs and up to eight digital I/O provide resources for application specific functions. Figure 1 shows a typical application schematic using the IRMCK099.

IRMCK099 contains 16 Kbytes of OTP program memory and comes in a compact 5mm x 5mm 32-pin QFN package.

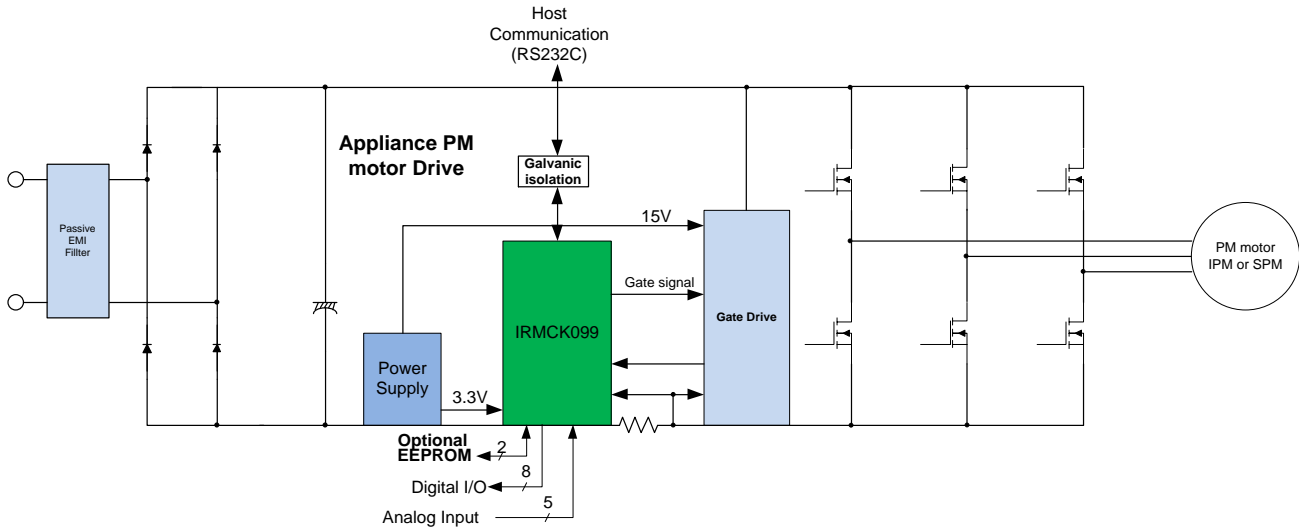

**Figure 1. Typical Application Block Diagram Using IRMCK099**

## 2 Pinout

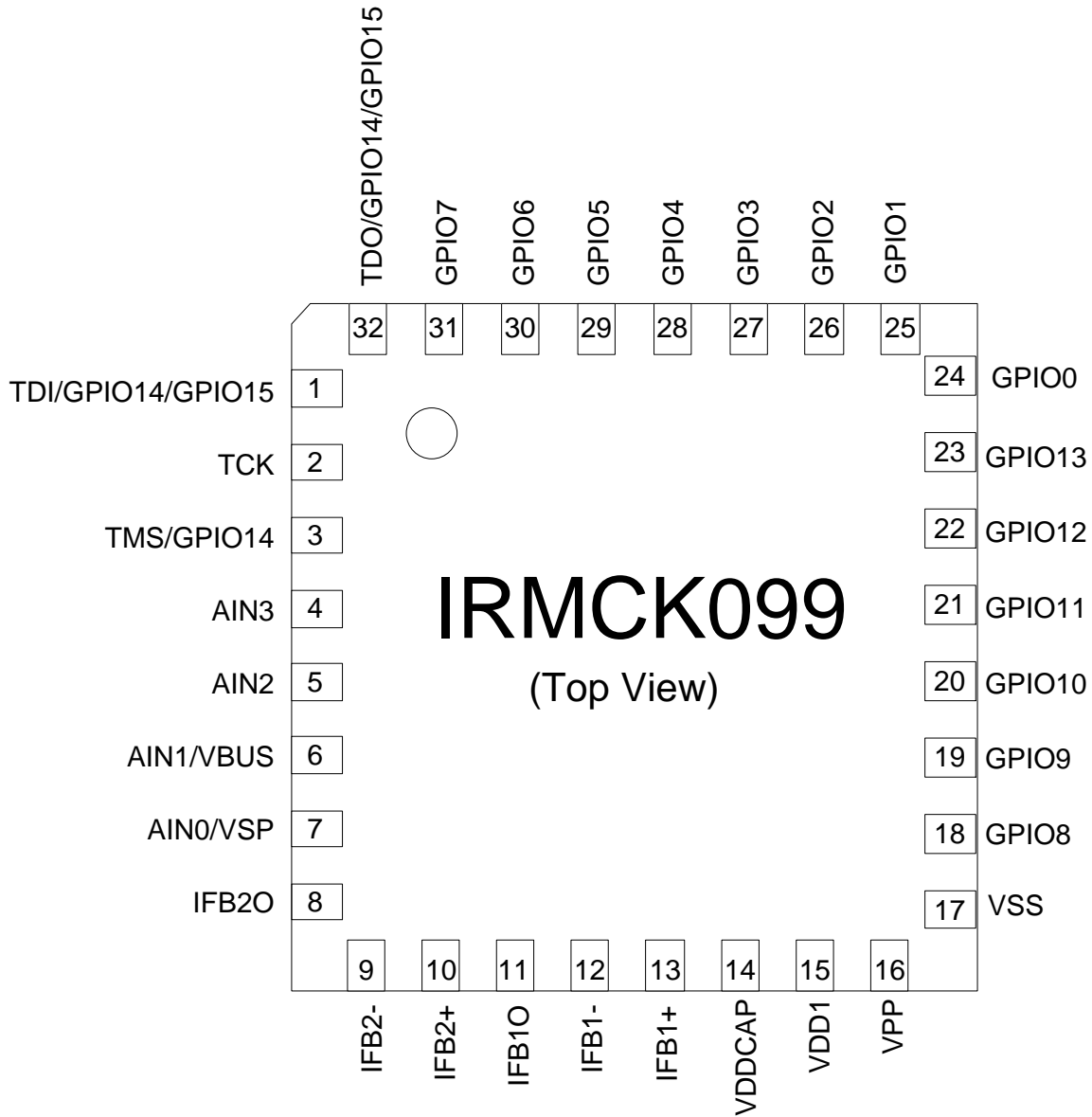

Figure 2. Pinout of IRMCK099

Pin Number	Pin Name	Main Function (After Reset) <sup>(1)</sup>	Remap <sup>(1) (2)</sup>	
1	TDI/GPIO14/GPIO15	TDI	GATEKILL PWMUL PWMUH PWMVL PWMVH PWMWL PWMWH AOPWM0 AOPWM1 RXD TXD SDA SCL CAPTURE	
3	TMS/GPIO14	TMS		
18	GPIO8	(1)		
19	GPIO9			
20	GPIO10			
21	GPIO11			
22	GPIO12			
23	GPIO13			
24	GPIO0			
25	GPIO1			
26	GPIO2			
27	GPIO3			
28	GPIO4			
29	GPIO5			
30	GPIO6			
31	GPIO7			
32	TDO/GPIO14/GPIO15			TDO

**Table 1 Remap functions available on GPIO**

Note (1)-Function availability depends on the provided firmware and for more information refer to the Application pin out section of the IRMCK099 application guide.

Note (2)-Only one pin can be remapped to one of the provided functions at the same time, for more information refer to the Application pin out section of the IRMCK099 application guide.



### 3 IRMCK099 Block Diagram and Main Functions

IRMCK099 block diagram for leg shunt mode is shown in Figure 3.

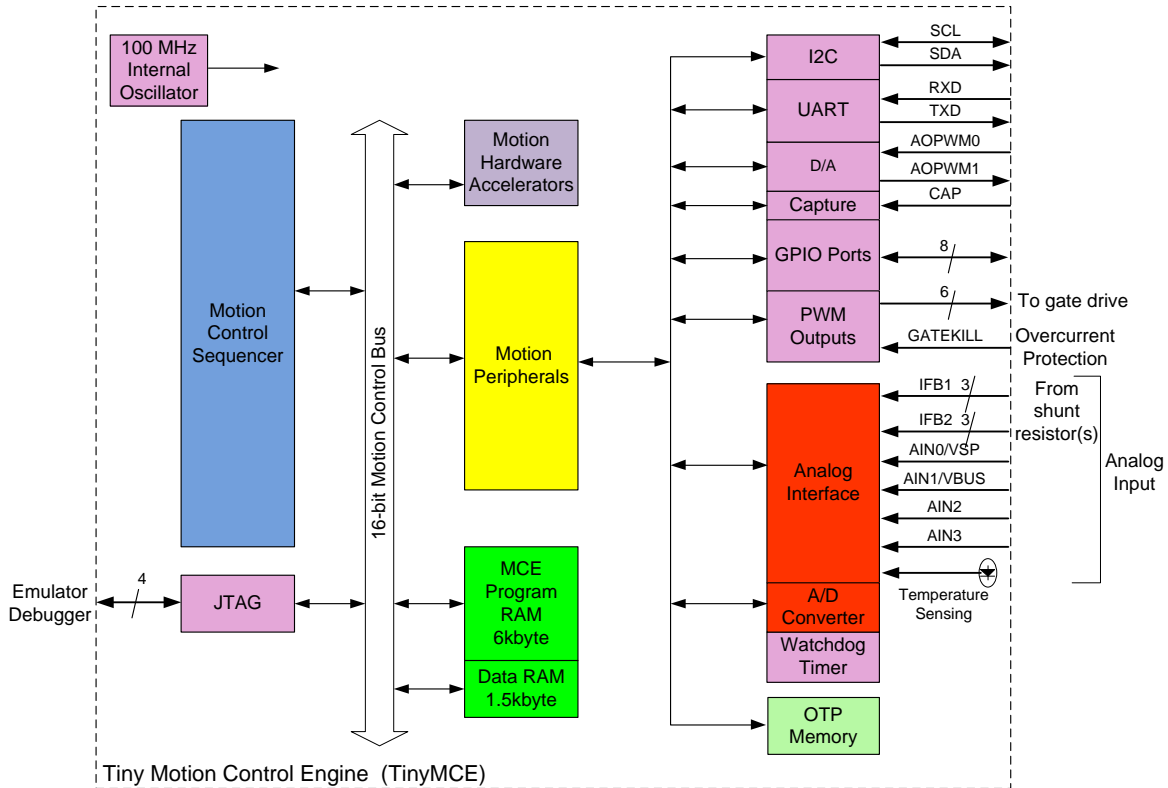

**Figure 3. IRMCK099 Block Diagram**

IRMCK099 contains the following functions for sensorless permanent magnet motor control applications:

#### Tiny Motion Control Engine (TinyMCE)

- Sensorless FOC (complete sensorless field oriented control)
  - PI Speed Regulator
  - 2-channel PI Current regulators (q & d quadratures)
  - Angle estimator (sensorless control)
  - Clark/Inverse Clark transformation
  - Vector rotator
  - No parking
  - Torque at low to zero speed
  - Multiply-divide (signed and unsigned)
  - Divide (signed and unsigned)
  - ATAN (arc tangent)
- Hardware PWM shutdown pin (GK)
- Up to 20kHz PWM Frequency
- One 16 bit watchdog timer
- One 16 bit capture timer
- Up to 8 discrete digital I/Os
- Six-channel 12 bit A/D
  - Buffered (current sensing) two channels (0 – 1.2V input)
  - Unbuffered four channels (0 – 1.2V input)
- JTAG port (4 pins)
- Two channels analog output (8 bit PWM)
- UART
- I<sup>2</sup>C port
- Standby Low Power Mode
- 1.5K byte data RAM
- 12K byte program RAM
- 16K byte OTP memory

## 4 Application connection and Pin function

Figure 4 shows the application connections in leg shunt mode.

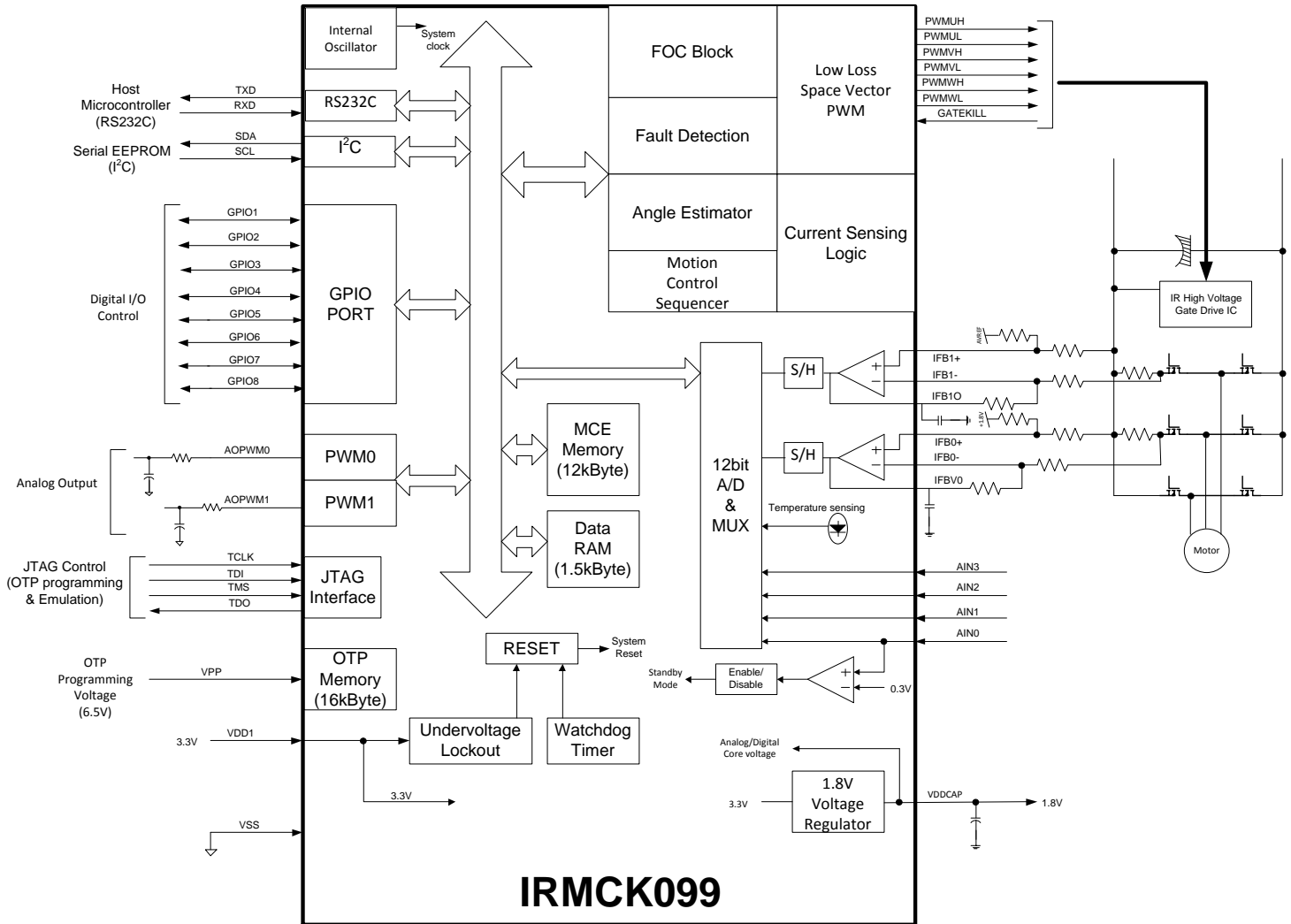

Figure 4. IRMCK099 Leg Shunt Connection Diagram

### 4.1 MCE Peripheral Interface Group

#### UART Interface

TXD Output, Transmit data from IRMCK099, can be configured to GPIO pins  
 RXD Input, Receive data to IRMCK099, can be configured to GPIO pins

#### Discrete I/O Interface

GPIO0 - GPIO15 Digital Input/Output Ports

**Analog Output Interface**

AOPWM1	Input/output, can be configured as 8-bit PWM output 1 with programmable carrier frequency
AOPWM2	Input/output, can be configured as 8-bit PWM output 2 with programmable carrier frequency

**I<sup>2</sup>C Interface**

SCL	Output, I <sup>2</sup> C clock output, can be configured to GPIO pins
SDA	Input/output, I <sup>2</sup> C Data line, can be configured to GPIO pins

**Capture Interface**

CAP	Capture Input, can be configured to GPIO pins
-----	---

**4.2 Motion Peripheral Interface Group**
**PWM**

PWMUH	Output, PWM phase U high side gate signal, tri-state at power up until configured by firmware
PWMUL	Output, PWM phase U low side gate signal, tri-state at power up until configured by firmware
PWMVH	Output, PWM phase V high side gate signal, tri-state at power up until configured by firmware
PWMVL	Output, PWM phase V low side gate signal, tri-state at power up until configured by firmware
PWMWH	Output, PWM phase W high side gate signal, tri-state at power up until configured by firmware
PWMWL	Output, PWM phase W low side gate signal, tri-state at power up until configured by firmware

**GATEKILL**

GK	Input, upon assertion this sets all six PWM signals to off state according to setting of active_pol register, pulled up by 49kOhm internal resistor
----	---

**4.3 Analog Interface Group**

IFB1+	Input, Operational amplifier positive input for single or leg shunt resistor current sensing
IFB1-	Input, Operational amplifier negative input for single or leg shunt resistor current sensing
IFB1O	Output, Operational amplifier output for single or leg shunt resistor current sensing
IFB2+	Input, Operational amplifier positive input for 2 <sup>nd</sup> leg shunt resistor current sensing
IFB2-	Input, Operational amplifier negative input for 2 <sup>nd</sup> leg shunt resistor current sensing
IFB2O	Output, Operational amplifier output for 2 <sup>nd</sup> leg shunt resistor current sensing
AIN0/VSP	Input, Analog input channel 0 (0 – 1.2 V), also used for Standby Mode wake-up
AIN1/VBUS	Input, Analog input channel 1 (0 – 1.2 V), typically configured for DC bus voltage input
AIN2	Input, Analog input channel 2 (0 – 1.2 V), needs to be pulled down to VSS if unused
AIN3	Input, Analog input channel 3 (0 – 1.2 V), needs to be pulled down to VSS if unused

#### 4.4 Power Interface Group

VDD1	Digital and analog power (3.3V)
VDDCAP	Internal 1.8V output, require capacitors connected to the pin. <b>Note:</b> The internal 1.8V supply is not designed to power any external circuits or devices. Only capacitors should be connected to this pin.
VSS	Digital and Analog common

#### 4.5 Test Interface Group

TMS	JTAG test mode input or input digital port
TDO	JTAG data output
TDI	JTAG data input, or input digital port
TCK	JTAG test clock

## 5 DC Characteristics

### 5.1 Absolute Maximum Ratings

Symbol	Parameter	Min	Typ	Max	Condition
$V_{DD1}$	Supply Voltage	-0.3 V	-	3.6 V	Respect to VSS
$V_{IA}$	Analog Input Voltage	-0.3 V	-	1.98 V	Respect to VSS
$V_{ID}$	Digital Input Voltage	-0.3 V	-	3.6 V	Respect to VSS
$T_A$	Ambient Temperature	-40 °C	-	125 °C	
$T_S$	Storage Temperature	-65 °C	-	150 °C	

**Table 2. Absolute Maximum Ratings**

**Caution:** Stresses beyond those listed in “Absolute Maximum Ratings” may cause permanent damage to the device. These are stress ratings only and function of the device at these or any other conditions beyond those indicated in the operational sections of the specifications are not implied.

### 5.2 System Clock Frequency and Power Consumption

$V_{DD1}=3.3V$ , Unless specified,  $T_a = 25^{\circ}C$ .

Symbol	Parameter	Min	Typ	Max	Unit
SYCLK	System Clock	-	100	-	MHz
$P_D$	Power Consumption		100 <sup>1)</sup>	-	mW
$P_{STBY}$	Standby Power Consumption		3.5		mW

**Table 3. System Clock Frequency and Power Consumption**

Note

1) The value is based on the condition of MCE clock=100MHz with an actual motor running by a typical TinyMCE application program.

### 5.3 Digital I/O DC Characteristics

Symbol	Parameter	Min	Typ	Max	Condition
$V_{DD1}$	Supply Voltage	3.0 V	3.3 V	3.6 V	Recommended
$V_{IL}$	Input Low Voltage	-	-	0.8 V	Recommended
$V_{IH}$	Input High Voltage	2.0 V		-	Recommended
$C_{IN}$	Input capacitance	-	1.6 pF	-	(1)
$I_L$	Input leakage current		$\pm 10$ nA	$\pm 1$ $\mu$ A	$V_O = 3.3$ V or 0 V
$I_{OL}$	Low level output current	14.1mA	22.9mA	31.8mA	$V_{OL} = 0.4$ V (1)
$I_{OH}$	High level output current	21.8mA	44.2mA	73.5mA	$V_{OH} = 2.4$ V (1)

**Table 4. Digital I/O DC Characteristics**

Note:

(1) Data guaranteed by design.

## 5.4 Analog I/O DC Characteristics

- OP amps for current sensing (IFB1+,IFB1-,IFB1O, IFB2+,IFB2-,IFB2O)

V<sub>DD1</sub>=3.3V, Unless specified, T<sub>a</sub> = 25°C.

Symbol	Parameter	Min	Typ	Max	Condition
V <sub>OFFSET</sub>	Input Offset Voltage	-20mV	3mV	20mV	V <sub>VDD1</sub> = 3.3 V
V <sub>I</sub>	Input Voltage Range	0 V		1.25 V	Recommended
V <sub>OUTSW</sub>	OP amp output operating range	50 mV <sup>(1)</sup>	-	1.7 V	V <sub>VDD1</sub> = 3.3 V
C <sub>IN</sub>	Input capacitance	-	3.6 pF	-	
R <sub>FDBK</sub>	OP amp feedback resistor	5 kΩ	-	20 kΩ	Requested between IFBO and IFB-
OP <sub>GAINCL</sub>	Operating Open loop Gain	-	80 db	-	<sup>(1)</sup>
CMRR	Common Mode Rejection Ratio	-	80 db	-	<sup>(1)</sup>
I <sub>SRC</sub>	Op amp output source current	-	1 mA	-	V <sub>OUT</sub> = 0.6 V
I <sub>SNK</sub>	Op amp output sink current	-	100 μA	-	V <sub>OUT</sub> = 0.6 V

**Table 5. Analog I/O DC Characteristics**

Note:

(1) Data guaranteed by design.

## 5.5 A/D Accuracy and Linearity

Unless specified, T<sub>a</sub> = 25°C.

A/D accuracy for current sensing (IFB1+,IFB1-,IFB1O, IFB2+,IFB2-,IFB2O), V<sub>dc</sub> (AIN1) sensing and analog input channels (AIN0,AIN2, AIN3)

Symbol	Parameter	Min	Typ	Max	Condition
ADC <sub>error</sub>	Error is the difference between ideal counts and compensated counts for any applied voltage in 0-1.2V range	0	±10Counts	±20counts	<sup>(1)</sup>
ADC <sub>INL</sub>	Integral Non Linearity			±4 counts	<sup>(1)</sup> <sup>(2)</sup> Full 12bit range
ADC <sub>DNL</sub>	Differential Non Linearity			±1.4 counts	<sup>(1)</sup> <sup>(2)</sup> Full 12bit range

**Table 5. A/D Accuracy**

Note:

(1) Characterization only

(2) The value is based on the condition of MCE clock=100MHz with an actual motor running by a typical TinyMCE application program.

## 5.6 Under Voltage Lockout DC characteristics

Unless specified,  $T_a = 25^\circ\text{C}$ .

Symbol	Parameter	Min	Typ	Max	Condition
$UV_{CC3.3+}$	UVcc positive going Threshold	2.55V	2.78V	3.00V	
$UV_{CC3.3-}$	UVcc negative going Threshold	2.40V	2.65V	2.85V	
$UV_{CC3.3H}$	UVcc Hysteresys	-	100mV	-	(1)

**Table 6. UVcc 3.3V DC Characteristics**

Note:

(1) Data guaranteed by design.

## 5.7 Itrip comparator DC characteristics

Unless specified,  $V_{DD1}=3.3\text{V}$ ,  $T_a = 25^\circ\text{C}$ .

Symbol	Parameter	Min	Typ	Max	Condition
$Itrip_+$	Itrip positive going Threshold	1.282V	1.342V	1.402V	$V_{DD1} = 3.3\text{ V}$ , $T_a=0-85\text{C}^{(2)}$
$Itrip_-$	Itrip negative going Threshold	1.05V	1.124V	1.25V	$V_{DD1} = 3.3\text{ V}$
$ItripH$	Itrip Hysteresys	0.05V	0.218V	0.3V	(1)

**Table 7. Itrip DC Characteristics**

Note:

(1) Data guaranteed by design.

(2) Characterization only.

## 5.8 Wake-up threshold DC characteristics

Unless specified,  $V_{DD1}=3.3\text{V}$ ,  $T_a = 25^\circ\text{C}$ .

Symbol	Parameter	Min	Typ	Max	Condition
$V_{WK}$	Exit from Standby Threshold	0.285V	0.315V	0.345V	$V_{DD1} = 3.3\text{ V}$

**Table 8. Wake-up threshold DC Characteristics**

## 5.9 Integrated Temperature Sensor

Unless specified,  $V_{DD1}=3.3\text{V}$

Symbol	Parameter	Min	Typ	Max	Condition
$T_{sense}$	Integrated $T_{sense}$ Error	-	$\pm 5^\circ\text{C}$	-	$V_{DD1} = 3.3\text{ V}$ $T_a = -40^\circ\text{C}, 25^\circ\text{C}, 125^\circ\text{C}$

**Table 8. Wake-up threshold DC Characteristics**



## 6 AC Characteristics

### 6.1 Internal Oscillator AC Characteristics

Unless specified,  $T_a = 25^\circ\text{C}$ .  $V_{DD1} = 3.3\text{V}$

Symbol	Parameter	Min	Typ	Max	Condition
F <sub>CLK</sub>	Clock Frequency	99MHz	100.0MHz	101MHz	T <sub>a</sub> =-40C – 125C
		95.8MHz <sup>(1)</sup>		104.4MHz <sup>(1)</sup>	

Note:

(1) Characterization only

**Table 9. Internal Oscillator AC Characteristics**

### 6.2 Analog to Digital Converter AC Characteristics

Unless specified,  $T_a = 25^\circ\text{C}$ .

Symbol	Parameter	Min	Typ	Max	Condition
T <sub>CONV</sub>	Conversion time	-	-	2.05 μsec	<sup>(1)</sup>
T <sub>HOLD</sub>	Sample/Hold maximum hold time	-	-	10 μsec	Voltage droop ≤ 15 LSB (see figure below)

**Table 10.A/D Converter AC Characteristics**

Note:

(1) Data guaranteed by design.

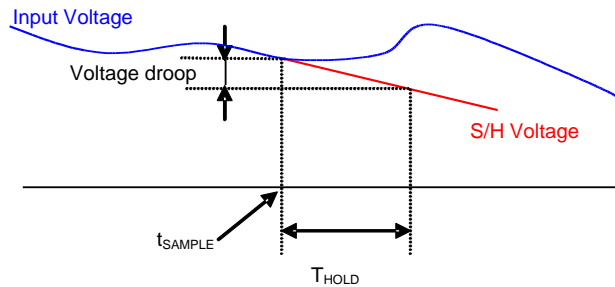

**Figure 5. Voltage droop and S/H hold time**

### 6.3 Op amp AC Characteristics

Unless specified, Ta = 25°C.

Symbol	Parameter	Min	Typ	Max	Condition
OP <sub>SR</sub>	OP amp slew rate	-	10 V/μsec	-	VDD1 = 3.3 V, CL = 33 pF <sup>(1)</sup>
OP <sub>IMP</sub>	OP input impedance	-	10 <sup>8</sup> Ω	-	<sup>(1)</sup> <sup>(2)</sup>
T <sub>SET</sub>	Settling time	-	400 ns	-	VDD1 = 3.3 V, CL = 33 pF <sup>(1)</sup>

**Table 11 Current Sensing OP Amp AC Characteristics**

Note:

- (1) Data guaranteed by design.
- (2) To guarantee stability of the operational amplifier, it is recommended to load the output pin by a capacitor of 100pF, see Figure 6. Here only the single shunt current amplifier is shown but all op amp outputs should be loaded with this capacitor value.

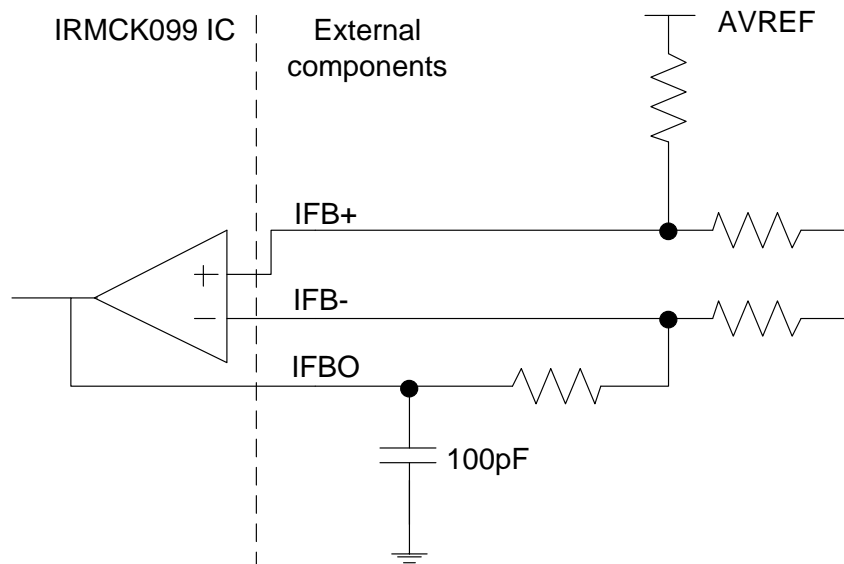

**Figure 6. Op amp output capacitor**

### 6.4 SYNC to SVPWM and A/D Conversion AC Timing

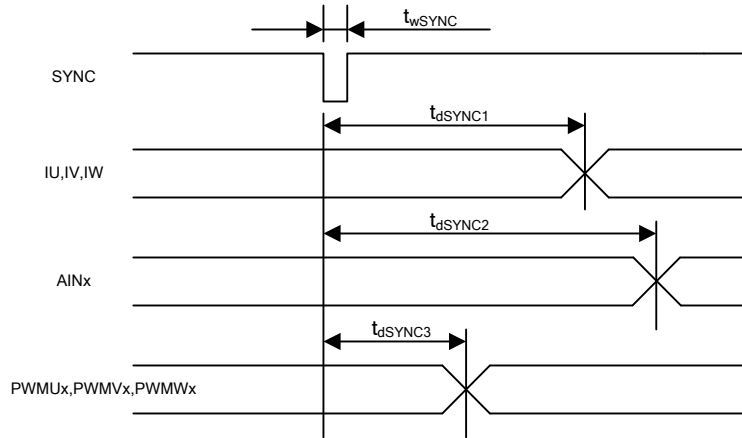

**Figure 7. SYNC timing**

Unless specified, Ta = 25°C.

Symbol	Parameter	Min	Typ	Max	Unit
$t_{wSYNC}$	SYNC pulse width	-	32	-	SYSCLK (1)
$t_{dSYNC1}$	SYNC to current feedback conversion time	-	-	100	
$t_{dSYNC2}$	SYNC to AIN0-3	-	-	200	
$t_{dSYNC3}$	SYNC to PWM output time	-	-	2	

**Table 12. SYNC AC Characteristics**

Note:

(1) Characterization only

### 6.5 FAULT to SVPWM AC Timing

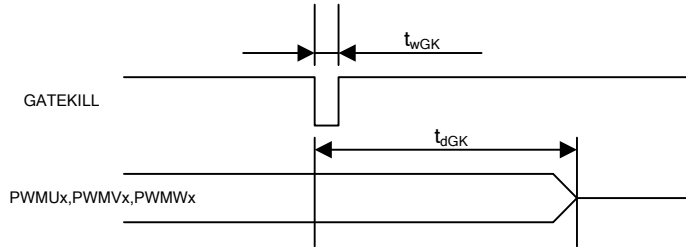

**Figure 8. Fault timing**

Unless specified, Ta = 25°C.

Symbol	Parameter	Min	Typ	Max	Unit
t <sub>wGK</sub>	FAULT pulse width	32	-	-	SYCLK
t <sub>dGK</sub>	FAULT to PWM output delay	-	-	100	SYCLK

**Table 13. FAULT to SVPWM AC Timing**

### 6.6 ITRIP AC Timing

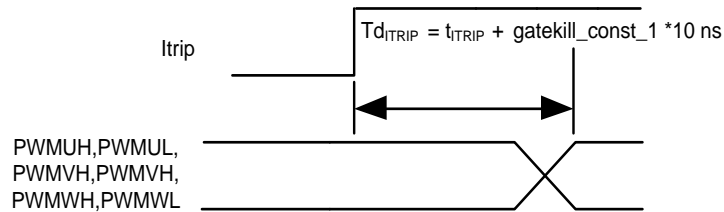

**Figure 9. ITRIP timing**

Unless specified, Ta = 25°C.

Symbol	Parameter	Min	Typ	Max	Unit
t <sub>ITRIP</sub>	Itrip propagation delay	-	470ns	-	ns <sup>(1)</sup>

**Table 14. Itrip AC Timing**

Note:

(1) Characterization only

### 6.7 I<sup>2</sup>C AC Timing

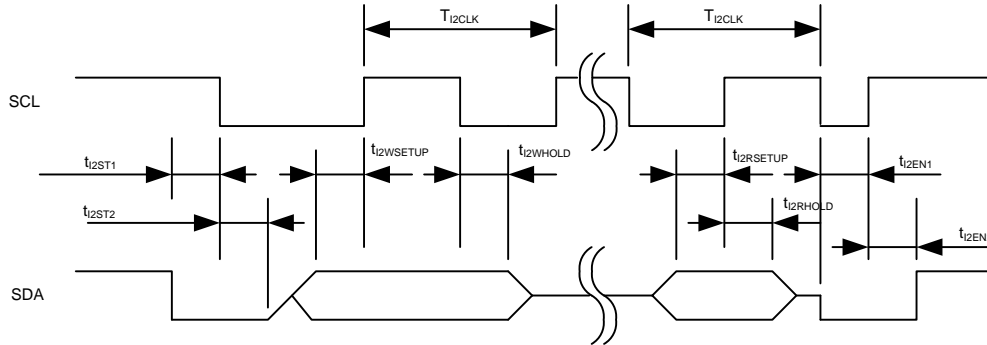

**Figure 10. I<sup>2</sup>C Timing**

Unless specified, Ta = 25°C.

Symbol	Parameter	Min	Typ	Max	Unit
$T_{12CLK}$	I <sup>2</sup> C clock period	10	-	-	SYCLK
$t_{12ST1}$	I <sup>2</sup> C SDA start time	0.25	-	-	$T_{12CLK}$
$t_{12ST2}$	I <sup>2</sup> C SCL start time	0.25	-	-	$T_{12CLK}$
$t_{12WSETUP}$	I <sup>2</sup> C write setup time	0.25	-	-	$T_{12CLK}$
$t_{12WHOLD}$	I <sup>2</sup> C write hold time	0.25	-	-	$T_{12CLK}$
$t_{12RSETUP}$	I <sup>2</sup> C read setup time	I <sup>2</sup> C filter time <sup>(1)</sup>	-	-	SYCLK
$t_{12RHOLD}$	I <sup>2</sup> C read hold time	1	-	-	SYCLK

**Table 15. I<sup>2</sup>C AC Timing**

Note:

(1) I<sup>2</sup>C read setup time is determined by the programmable filter time applied to I<sup>2</sup>C communication.

### 6.8 UART AC Timing

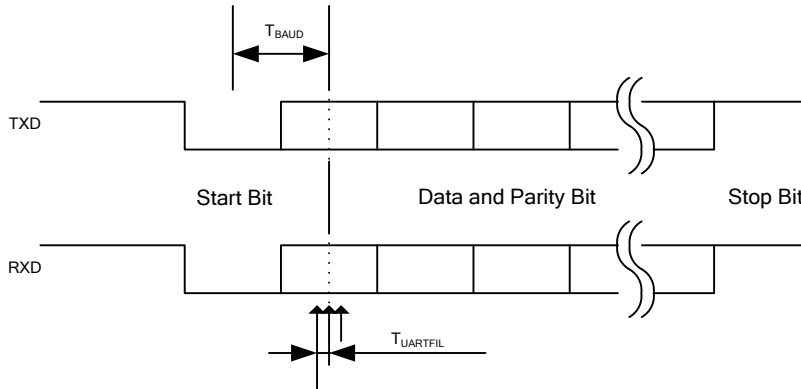

**Figure 11. UART timing**

Unless specified,  $T_a = 25^\circ\text{C}$ .

Symbol	Parameter	Min	Typ	Max	Unit
$T_{BAUD}$	Baud Rate Period	-	57600	-	bit/sec
$T_{UARTFIL}$	UART sampling filter period <sup>(1)</sup>	-	1/16	-	$T_{BAUD}$

**Table 16. UART AC Timing**

Note:

- (1) Each bit including start and stop bit is sampled three times at center of a bit at an interval of  $1/16 T_{BAUD}$ . If three sampled values do not agree, then UART noise error is generated.

### 6.9 CAPTURE Input AC Timing

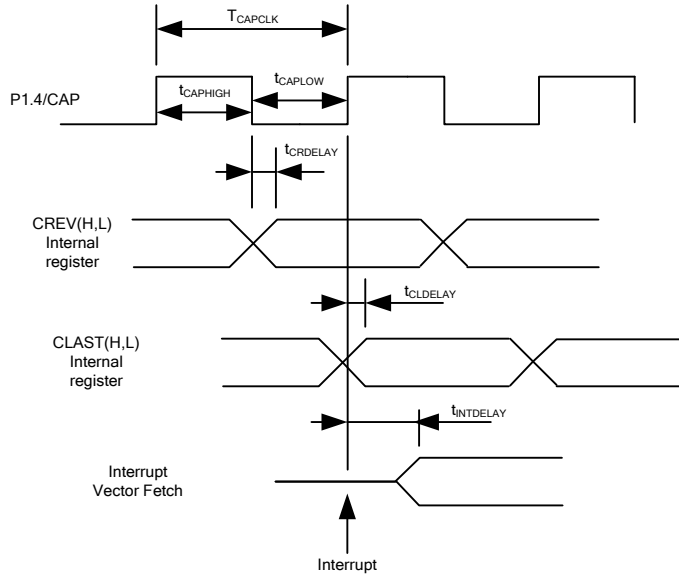

**Figure 12. CAPTURE timing**

Unless specified, Ta = 25°C.

Symbol	Parameter	Min	Typ	Max	Unit
T <sub>CAPCLK</sub>	CAPTURE input period	8	-	-	SYSCCLK
t <sub>CAPHIGH</sub>	CAPTURE input high time	4	-	-	SYSCCLK
t <sub>CAPLOW</sub>	CAPTURE input low time	4	-	-	SYSCCLK
t <sub>CRDELAY</sub>	CAPTURE falling edge to capture register latch time	-	-	4	SYSCCLK
t <sub>CLDELAY</sub>	CAPTURE rising edge to capture register latch time	-	-	4	SYSCCLK
t <sub>INTDELAY</sub>	CAPTURE input interrupt latency time	-	-	4	SYSCCLK

**Table 17. CAPTURE AC Timing**

### 6.10 JTAG AC Timing

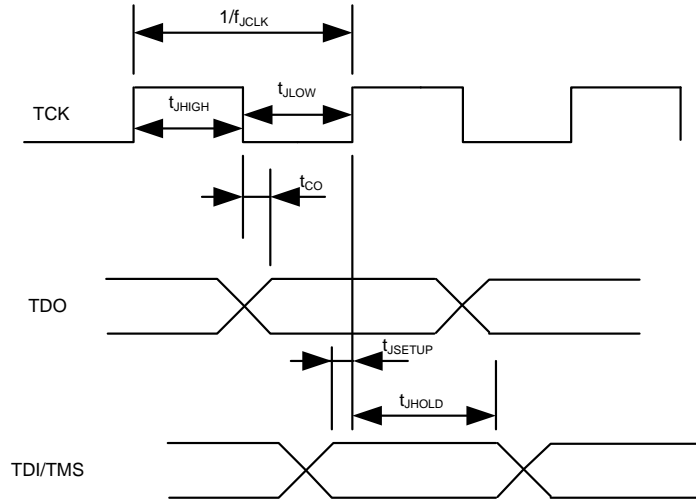

**Figure 13. JTAG timing**

Unless specified, Ta = 25°C.

Symbol	Parameter	Min	Typ	Max	Unit
f <sub>JCLK</sub>	TCK Frequency	-	-	10	MHz
t <sub>JHIGH</sub>	TCK High Period	10	-	-	nsec
t <sub>JLOW</sub>	TCK Low Period	10	-	-	nsec
t <sub>CO</sub>	TCK to TDO propagation delay time	0	-	5	nsec
t <sub>JSETUP</sub>	TDI/TMS setup time	4	-	-	nsec
t <sub>JHOLD</sub>	TDI/TMS hold time	0	-	-	nsec

**Table 18. JTAG AC Timing**



## 7 I/O Structure

The following figure shows the I/O structure for all digital pins. At power up, the programmable pull up transistor is off.

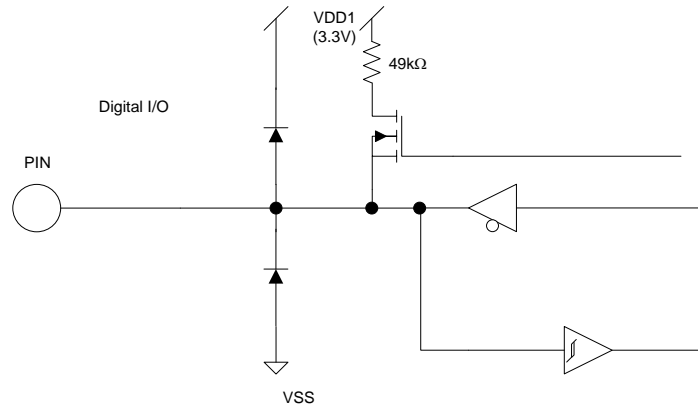

**Figure 14. Digital I/O Structure**

The following figure shows the analog input/output structure, except for AIN0/STBY.

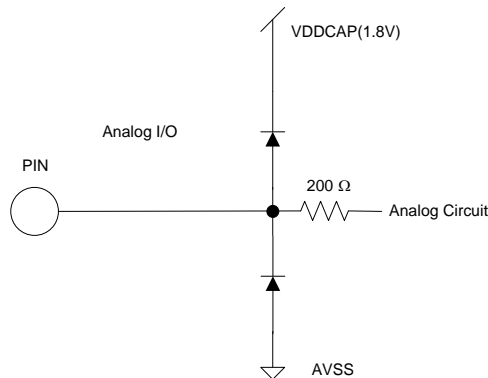

**Figure 15. Analog I/O Structure**

The following figure shows all the input structure for AIN0/STBY pin.

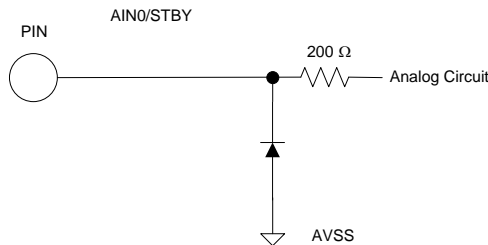

**Figure 16 Analog Analog Input Structure for AIN0/STBY**

The following figure shows the VSS pin I/O structure

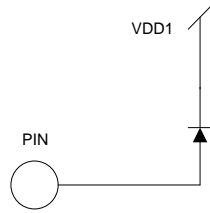

**Figure 17. VSS pin I/O structure**

The following figure shows the, VDDCAP pin I/O structure

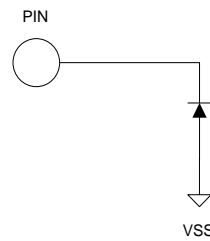

**Figure 18. VDDCAP pin I/O structure**

The following figure shows the, VDD1 pin I/O structure

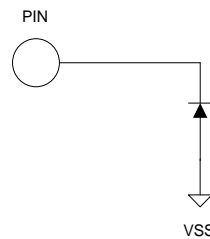

**Figure 19. VDD1 pin I/O structure**

## 8 Pin List

Pin Number	Pin Name	Internal Pull-up	Pin Type	Description
1	TDI/GPIO14/GPIO15	49 K $\Omega$ pull up <sup>(1)</sup>	I	JTAG test data input or Discrete programmable I/O
2	TCK	49 K $\Omega$ pull up <sup>(1)</sup>	I	JTAG test clock
3	TMS/GPIO14	49 K $\Omega$ pull up <sup>(1)</sup>	I/O	JTAG test mode input or Discrete programmable I/O
4	AIN3		I	Analog input channel 3, 0-1.2V range, needs to be pulled down to VSS if unused
5	AIN2		I	Analog input channel 2, 0-1.2V range, needs to be pulled down to VSS if unused
6	AIN1/VBUS		I	Analog input channel 1, 0-1.2V range, used for DC Bus Voltage Input
7	AIN0/STBY		I	Analog input channel 0, 0-1.2V range, exit standby if >300mV
8	IFB2O		O	Operational amplifier output for 2 <sup>nd</sup> leg shunt resistor current sensing
9	IFB2-		I	Operational amplifier negative input for 2 <sup>nd</sup> leg shunt resistor current sensing
10	IFB2+		I	Operational amplifier positive input for 2 <sup>nd</sup> leg shunt resistor current sensing
11	IFB1O		O	Operational amplifier output for single or leg shunt resistor current sensing
12	IFB1-		I	Operational amplifier negative input for single or leg shunt resistor current sensing
13	IFB1+		I	Operational amplifier positive input for single or leg shunt resistor current sensing
14	VDDCAP		P	Internal 1.8V output, Capacitor(s) to be connected
15	VDD1		P	3.3V digital and analog power
16	VPP		P	OTP Programming voltage (6.75V)
17	VSS		P	Digital common
18	GPIO8	49 K $\Omega$ pull up <sup>(1)</sup>	I/O	Discrete programmable I/O
19	GPIO9	49 K $\Omega$ pull up <sup>(1)</sup>	I/O	Discrete programmable I/O
20	GPIO10	49 K $\Omega$ pull up <sup>(1)</sup>	I/O	Discrete programmable I/O
21	GPIO11	49 K $\Omega$ pull up <sup>(1)</sup>	I/O	Discrete programmable I/O
22	GPIO12	49 K $\Omega$ pull up <sup>(1)</sup>	I/O	Discrete programmable I/O
23	GPIO13	49 K $\Omega$ pull up <sup>(1)</sup>	I/O	Discrete programmable I/O
24	GPIO0	49 K $\Omega$ pull up <sup>(1)</sup>	I/O	Discrete programmable I/O
25	GPIO1	49 K $\Omega$ pull up <sup>(1)</sup>	I/O	Discrete programmable I/O
26	GPIO2	49 K $\Omega$ pull up <sup>(1)</sup>	I/O	Discrete programmable I/O
27	GPIO3	49 K $\Omega$ pull up <sup>(1)</sup>	I/O	Discrete programmable I/O
28	GPIO4	49 K $\Omega$ pull up <sup>(1)</sup>	I/O	Discrete programmable I/O
29	GPIO5	49 K $\Omega$ pull up <sup>(1)</sup>	I/O	Discrete programmable I/O
30	GPIO6	49 K $\Omega$ pull up <sup>(1)</sup>	I/O	Discrete programmable I/O
31	GPIO7	49 K $\Omega$ pull up <sup>(1)</sup>	I/O	Discrete programmable I/O
32	TDO/GPIO14/GPIO15	49 K $\Omega$ pull up <sup>(1)</sup>	O	JTAG test data output or Discrete programmable I/O

**Table 19. Pin List**

<sup>(1)</sup> Programmable internal pull up

## 9 Package Dimensions

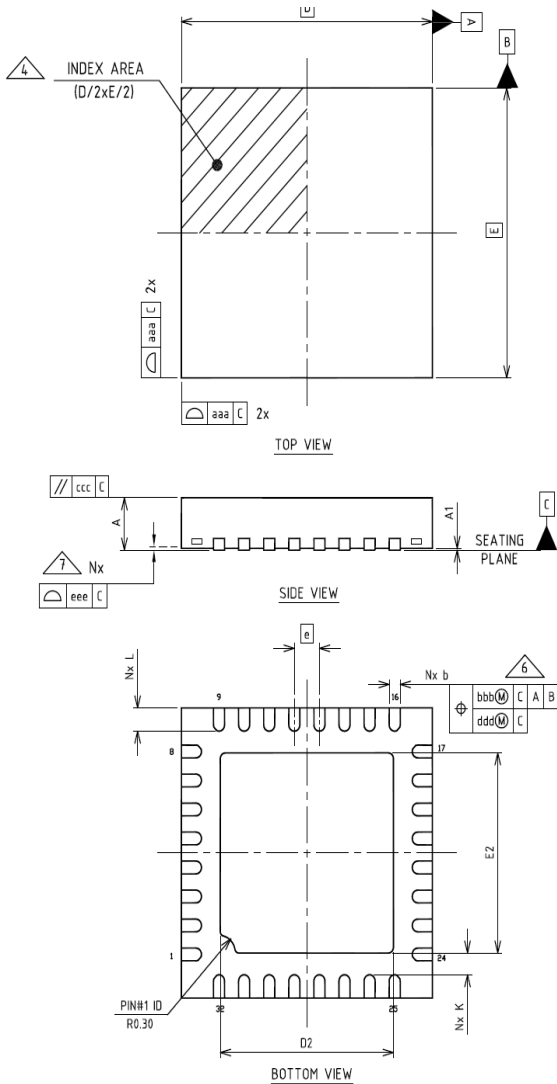

Dimension Table				
Thickness Symbol	W : Very Very Thin			NOTE
	MINIMUM	NOMINAL	MAXIMUM	
A	0.70	0.75	0.80	
A1	0.00	0.02	0.05	
b	0.18	0.25	0.30	6
D	5.00 BSC			
E	5.00 BSC			
e	0.50 BSC			
D2	3.30	3.45	3.55	
E2	3.30	3.45	3.55	
K	0.20	---	---	
L	0.30	0.40	0.50	
aaa	0.05			
bbb	0.10			
ccc	0.10			
ddd	0.05			
eee	0.08			
N	32			3
ND	8			5
NE	8			5
NOTES	1, 2			
LF PART NO.	437727			
LF DWG. NO.	CARSEM-06257			
REV.	A			

**NOTE:**

1. Dimensioning and tolerancing conform to ASME Y14.5-2009.
2. All dimensions are in millimeters.
3. N is the total number of terminals.
4. The location of the marked terminal #1 identifier is within the hatched area.
5. ND and NE refer to the number of terminals on D and E side respectively.
6. Dimension b applies to the metallized terminal and is measured between 0.15mm and 0.30mm from the terminal tip. If the terminal has a radius on the other end of it, dimension b should not be measured in that radius area.
7. Coplanarity applies to the terminals and all other bottom surface metallization.

## 10 Part Marking Information

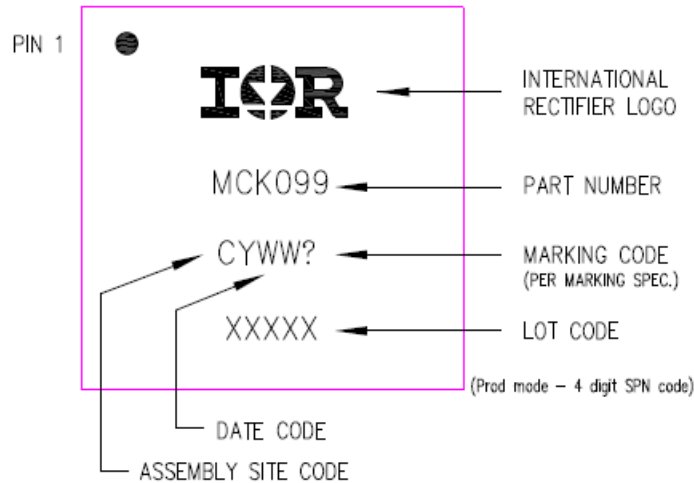

## 11 Qualification Information

<b>Qualification Level</b>		Industrial <sup>††</sup> (per JEDEC JESD47)
<b>Moisture Sensitivity Level</b>		MSL2 <sup>†††</sup> (per IPC/JEDEC J-STD-020)
<b>ESD</b>	<b>Machine Model</b>	Class B (per JEDEC standard JESD22-A115)
	<b>Human Body Model</b>	Class 2 (per ANSI/ESDA/JEDEC JS-001)
	<b>Charged Device Model</b>	Class C2 (per JEDEC standard JESD22-C101)
	<b>Latch-Up</b>	Class I, Level B (per JEDEC standard JESD78)
<b>RoHS Compliant</b>		Yes

† Qualification standards can be found at International Rectifier's web site <http://www.irf.com/>

†† Higher qualification ratings may be available should the user have such requirements. Please contact your International Rectifier sales representative for further information.

††† Higher MSL ratings may be available for the specific package types listed here. Please contact your International Rectifier sales representative for further information.

## Revision History

International  
 Rectifier

Data and Specifications are subject to change without notice  
**IR WORLD HEADQUARTERS:** 233 Kansas St., El Segundo, California 90245, USA Tel: (310) 252-7105  
TAC Fax: (310) 252-7903  
Visit us at [www.irf.com](http://www.irf.com) for sales contact information

## Trademarks of Infineon Technologies AG

$\mu$ HVIC™,  $\mu$ IPM™,  $\mu$ PFC™, AU-ConvertIR™, AURIX™, C166™, CanPAK™, CIPOST™, CIPURSE™, CoolDP™, CoolGaN™, COOLiR™, CoolMOS™, CoolSET™, CoolSiC™, DAVE™, DI-POL™, DirectFET™, DrBlade™, EasyPIM™, EconoBRIDGE™, EconoDUAL™, EconoPACK™, EconoPIM™, EiceDRIVER™, eupec™, FCOS™, GaNpowIR™, HEXFET™, HITFET™, HybridPACK™, iMOTION™, IRAM™, ISOFACE™, IsoPACK™, LEDriviR™, LITIX™, MIPAQ™, ModSTACK™, my-d™, NovalithIC™, OPTIGA™, OptiMOS™, ORIGA™, PowIRaudio™, PowIRStage™, PrimePACK™, PrimeSTACK™, PROFET™, PRO-SIL™, RASIC™, REAL3™, SmartLEWIS™, SOLID FLASH™, SPOC™, StrongIRFET™, SupIRBuck™, TEMPFET™, TRENCHSTOP™, TriCore™, UHVIC™, XHP™, XMC™

Trademarks updated November 2015

## Other Trademarks

All referenced product or service names and trademarks are the property of their respective owners.

### Edition 2014-12-18

#### Published by

Infineon Technologies AG

81726 München, Germany

© 2016 Infineon Technologies AG.

All Rights Reserved.

Do you have a question about this document?

Email: [erratum@infineon.com](mailto:erratum@infineon.com)

Document reference

ifx1

### IMPORTANT NOTICE

The information given in this document shall in no event be regarded as a guarantee of conditions or characteristics ("Beschaffensgarantie").

With respect to any examples, hints or any typical values stated herein and/or any information regarding the application of the product, Infineon Technologies hereby disclaims any and all warranties and liabilities of any kind, including without limitation warranties of non-infringement of intellectual property rights of any third party.

In addition, any information given in this document is subject to customer's compliance with its obligations stated in this document and any applicable legal requirements, norms and standards concerning customer's products and any use of the product of Infineon Technologies in customer's applications.

The data contained in this document is exclusively intended for technically trained staff. It is the responsibility of customer's technical departments to evaluate the suitability of the product for the intended application and the completeness of the product information given in this document with respect to suc

For further information on the product, technology, delivery terms and conditions and prices please contact your nearest Infineon Technologies office ([www.infineon.com](http://www.infineon.com)).

### WARNINGS

Due to technical requirements products may contain dangerous substances. For information on the types in question please contact your nearest Infineon Technologies office.

Except as otherwise explicitly approved by Infineon Technologies in a written document signed by authorized representatives of Infineon Technologies, Infineon Technologies' products may not be used in any applications where a failure of the product or any consequences of the use thereof can reasonably be expected to result in personal injury.

单击下面可查看定价，库存，交付和生命周期等信息

[>>Infineon Technologies\(英飞凌\)](#)