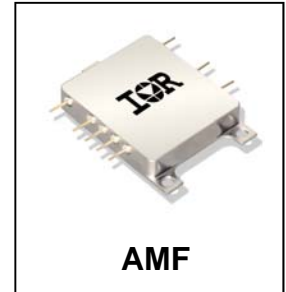

**HYBRID-HIGH RELIABILITY
RADIATION TOLERANT
DC-DC CONVERTER****28V Input, Dual Output****Description**

The AMF28XXD Series of DC-DC converter modules has been specifically designed for operation in moderate radiation environments supplementing the higher radiation performance available in the IR HiRel ART2815T converter series. Environments presented to space vehicles operating in low earth orbits, launch boosters, orbiting space stations and similar applications requiring a low power, high performance converter with moderate radiation hardness performance will be optimally served by the AMF28XXD Series.

The physical configuration of the AMF28XXD Series permits mounting directly to a heat conduction surface without the necessity of signal leads penetrating the heat sink surface. This package configuration permits greater independence in mounting and more mechanical security than traditional packages. IR HiRel rugged ceramic seal pins are used exclusively in the package thereby assuring long term hermeticity.

The AMF28XXD has been designed for high density using chip and wire hybrid technology that complies with the class H requirements of MIL-PRF-38534. Manufactured in a facility fully qualified to MIL-PRF-38534, these converters are fabricated utilizing DLA qualified processes. For available screening options, refer to device screening table in the data sheet. Applicable generic lot qualification test data including radiation performance can be made available on request. Variations to the standard screening can be accommodated. Consult IR HiRel San Jose for special requirements.

Features

- 12 Watts Output Power
- Available in ± 5 , ± 12 and ± 15 Volt Outputs
- 16- 40 V_{DC} Input Range (28 V_{DC} Nominal)
- Low Input/Output Noise
- Total Ionizing Dose > 25 kRads(Si)
- SEE Hardened to LET up to 60 MeV·cm²/mg
- -55°C to +125°C Operating Range
- Indefinite Short Circuit Protection
- Flexible Mounting
- High Power Density
- Fully Isolated - Input to Output and to Case
- Complimentary EMI Filter Available
- Externally Synchronizable
- Electrical Performance Similar to AHF28XXD Series
- Standard Microcircuit Drawings Available

Specifications

Absolute Maximum Ratings		Recommended Operating Conditions	
Input voltage range	-0.5V _{DC} to +50V _{DC}	Input voltage range	+16V _{DC} to +40V _{DC}
Soldering temperature	300°C for 10 seconds	Output power	Less than or equal to 12W
Storage case temperature	-65°C to +135°C	Operating temperature	-55°C to +125°C

Static Characteristics $-55^{\circ}\text{C} \leq T_{\text{CASE}} \leq +125^{\circ}\text{C}$, $V_{\text{IN}} = 28\text{V}_{\text{DC}} \pm 5\%$, $C_{\text{L}} = 0$, unless otherwise specified.

Parameter	Group A Subgroups	Test Conditions	Min	Nom	Max	Unit
Input Voltage			16	28	40	V
Output Voltage						
AMF2805D	1	$V_{\text{IN}} = 28$ Volts, 10% load on both outputs	±4.95	±5.00	±5.05	V
AMF2812D	1		±11.88	±12.00	±12.12	
AMF2815D	1		±14.85	±15.00	±15.15	
AMF2805D	2, 3		±4.90		±5.10	
AMF2812D	2, 3		±11.76		±12.24	
AMF2815D	2, 3		±14.70		±15.30	
Output Current ^{1,2}						
AMF2805D	1, 2, 3	$V_{\text{IN}} = 16, 28, 40$ Volts each output	240		2160	mA
AMF2812D	1, 2, 3		100		900	
AMF2815D	1, 2, 3		80		720	
Output Power ^{1,2}						
AMF2805D	1, 2, 3	$V_{\text{IN}} = 28$ Volts, 100% load			12	W
AMF2812D	1, 2, 3				12	
AMF2815D	1, 2, 3				12	
Output Ripple Voltage ^{1,3}						
AMF2805D	1, 2, 3	$V_{\text{IN}} = 16, 28, 40$ Volts 100% load BW = 20 Hz to 2 MHz		25	60	mV _{PP}
AMF2812D	1, 2, 3			25	60	
AMF2815D	1, 2, 3			25	60	
Output Voltage Regulation ³						
Line		$V_{\text{IN}} = 16, 28, 40$ Volts $I_{\text{OUT}} = 10, 50\%, 100\%$ load		±10	±25	mV
AMF2805D	1, 2, 3			±10	±50	
AMF2812D	1, 2, 3			±10	±50	
AMF2815D	1, 2, 3			±10	±50	
Load				±10	±50	
AMF2805D	1, 2, 3			±10	±50	
AMF2812D	1, 2, 3		±10	±50		
AMF2815D	1, 2, 3		±10	±50		

For Notes to Electrical Performance Characteristics, refer to page 4

Static Characteristics (Continued) $-55^{\circ}\text{C} \leq T_{\text{CASE}} \leq +125^{\circ}\text{C}$, $V_{\text{IN}} = 28V_{\text{DC}} \pm 5\%$, $C_{\text{L}} = 0$, unless otherwise specified.

Parameter	Group A Subgroups	Test Conditions	Min	Nom	Max	Unit
Cross Regulation ⁵						
AMF2805D	1, 2, 3	Minimum 1.0 watt on both outputs 20% - 90% load			10	%
AMF2812D	1, 2, 3				3.0	
AMF2815D	1, 2, 3				3.0	
Input Current						
No Load		$V_{\text{IN}} = 28$ Volts $I_{\text{OUT}} = 0$, Inhibit (pin 1) = open		35	60	mA
AMF2805D	1, 2, 3			35	60	
AMF2812D	1, 2, 3			35	60	
AMF2815D	1, 2, 3					
Inhibit		Inhibit (pin1) shorted to Input return (pin 7)		8.0	12	
AMF2805D	1, 2, 3			8.0	12	
AMF2812D	1, 2, 3			8.0	12	
AMF2815D	1, 2, 3					
Input Ripple Current ³						
AMF2805D	1, 2, 3	$V_{\text{IN}} = 16, 28, 40$ Volts, 100% load, BW = 20 Hz to 2 MHz		20	50	mA _{PP}
AMF2812D	1, 2, 3			20	50	
AMF2815D	1, 2, 3			20	50	
Efficiency ³						
AMF2805D	1, 3	100% load	76			%
AMF2812D	1, 3		77			
AMF2815D	1, 3		78			
AMF2805D	2		72			
AMF2812D	2		74			
AMF2815D	2		74			
Isolation	1	Input to output or any pin to case (except pin 6) at $500V_{\text{DC}}$	100			M Ω
Capacitive Load ^{5,6}						
AMF2805D	4	No effect on dc performance, total for both outputs			500	μF
AMF2812D	4				200	
AMF2815D	4				200	
Short Circuit Power Dissipation	1, 2, 3				6.0	W
MTBF		MIL-HDBK-217F, SF @ 35°C	750			kHrs
Weight					36	g

For Notes to Electrical Performance Characteristics, refer to page 4

Dynamic Characteristics $-55^{\circ}\text{C} \leq T_{\text{CASE}} \leq +125^{\circ}\text{C}$, $V_{\text{IN}} = 28V_{\text{DC}} \pm 5\%$, $C_{\text{L}} = 0$, unless otherwise specified.

Parameter	Group A Subgroups	Test Conditions	Min	Nom	Max	Unit
Short Circuit Recovery ⁶						
AMF2805D AMF2812D AMF2815D	4, 5, 6	0% load to 100% load			25 25 25	ms
Switching Frequency ³	4, 5, 6	100% load	500	550	600	kHz
Synchronization Input ³						
Frequency Range Pulse Amplitude, Hi ⁶ Pulse Amplitude, Lo ⁶ Pulse Rise Time ⁶ Pulse Duty Cycle ⁶	4, 5, 6		500 2.5 -0.5 20		700 10 0.8 80	kHz V V ns %
Output Response To Step Transient Load Changes ^{3,7}	4, 5, 6 4, 5, 6	Load step 50% \leftrightarrow 100% Load step 0% \leftrightarrow 50%	-200 -800		+200 +800	mVpk
Recovery Time, Step Transient Load Changes ^{3,7,8}	4, 5, 6 4, 5, 6	Load step 50% \leftrightarrow 100% Load step 0% \leftrightarrow 50%			70 2000	μs
Output Response Transient Step Line Changes ^{3,6,9}						
AMF2805D AMF2812D AMF2815D	4, 5, 6 4, 5, 6 4, 5, 6	Input step 16 \leftrightarrow 40V _{DC} , 100% load	-450 -750 -750		+450 +750 +750	mVpk
Recovery Time Transient Step Line Changes ^{3,6,9}	4, 5, 6	Input step 16 \leftrightarrow 40V _{DC} , 100% load			1200	μs
Turn On Overshoot ^{3,10}						
All	4, 5, 6	0% load			600	mVpk
AMF2805D	4, 5, 6	100% load			400	
AMF2812D	4, 5, 6				300	
AMF2815D	4, 5, 6				300	
Turn On Delay ^{3,10}	4, 5, 6	0% load to 100% load			25	ms

Notes to Specifications

1. Applicable to positive and negative outputs..
2. Maximum combined output is 12 watts. 10.8 watts (max.) is available from either output (90%).
3. Load current split equally between +V_{OUT} and -V_{OUT}.
4. 1.2 watt load on output under test, 1.2 watt to 10.8 watt load change on other output.
5. Capacitive value may be any value from 0 to the maximum limit without compromising DC performance. A capacitive load in excess of the maximum limit will not disturb loop stability but may interfere with the operation of the load fault detection circuitry, appearing as a short circuit during turn-on.
6. Parameter shall be tested as part of design characterization and after design or process changes. Thereafter, parameters shall be guaranteed to the limit specified.
7. Load step transition time between 2.0 μs and 10 μs .
8. Recovery time is measured from initiation of the transient to where V_{OUT} has returned to within $\pm 1\%$ of V_{OUT} at 50% load.
9. Input step transient time between 1.0 μs and 10 μs .
- 10 Turn-on delay time measurement is for either a step application of power at the input or the removal of a ground signal from the inhibit pin while power is applied to the input.

Block Diagram

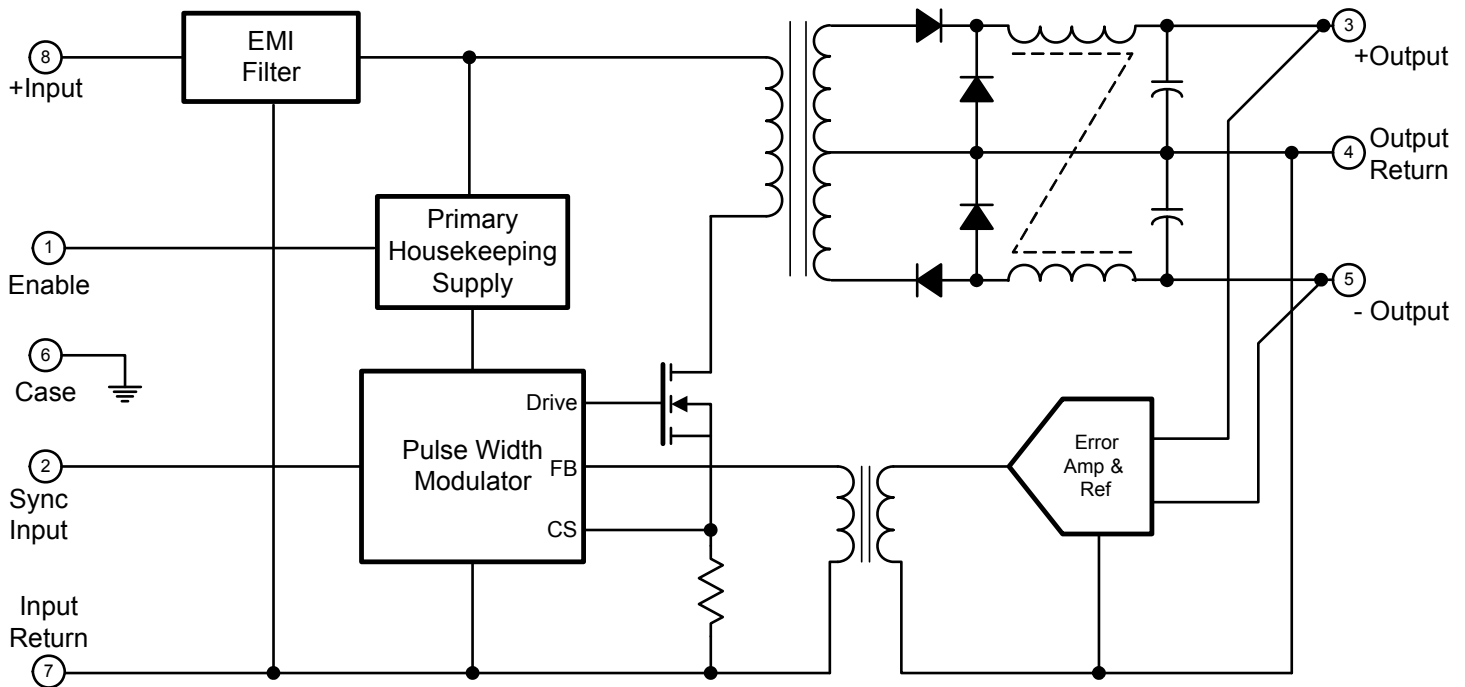

Application Information

Inhibit Function (Enable)

Connecting the enable input (Pin 1) to input common (Pin 7) will cause the converter to shut down. It is recommended that the enable pin be driven by an open collector device capable of sinking at least 400 μ A of current. Because it is internally pulled up, the open circuit voltage of the enable input is 10 +1.0 V_{DC} .

EMI Filter

An optional EMI filter is available (AFH461) that will reduce the input ripple current to levels below the limits imposed by MIL-STD-461 CE03.

Device Synchronization

When multiple DC-DC converters are utilized in a single system, significant low frequency noise may be generated due to a small difference in the switching frequency of the converters (beat frequency noise). Because of the low frequency nature of this noise (typically less than 10 kHz), it is difficult to filter out and may interfere with proper operation of sensitive systems (communication, radar or telemetry). IR HiRel provides synchronization of multiple AMF type converters to match switching frequency of the converter to the frequency of the system clock, thus eliminating this type of noise.

Radiation Specifications

Parameter	Condition	Min	Typ	Max	Unit
Total Ionizing Dose	MIL-STD-883, Method 1019.4 Operating bias applied during exposure	25			kRads (Si)
Heavy Ion (Single event effects)	BNL Dual Van de Graf Generator	60			MeV·cm ² /mg

IR HiRel currently does not have a DLA certified Radiation Hardness Assurance Program.

Mechanical Outline

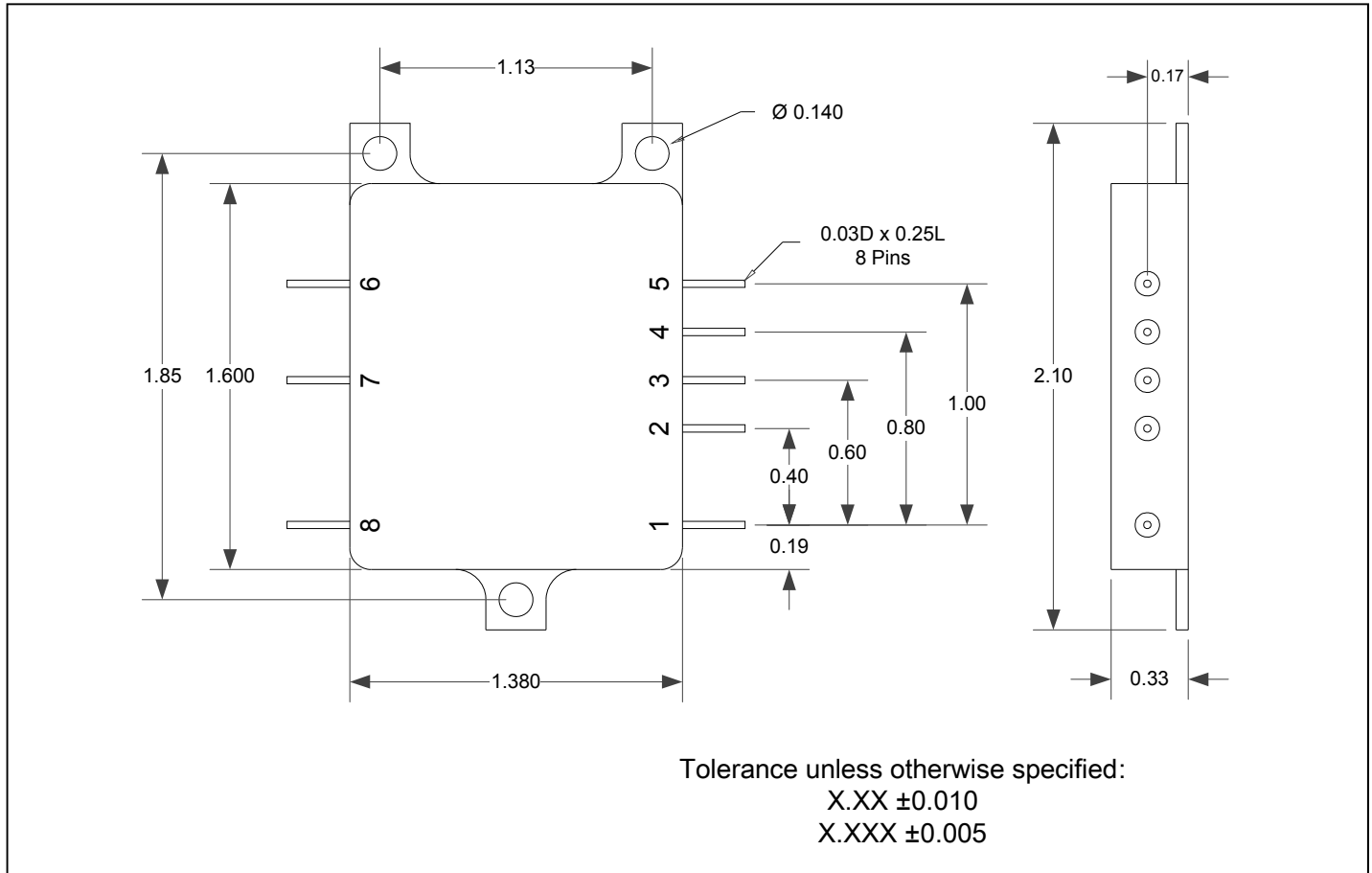

Pin Designation

Pin #	Designation
1	Enable
2	Sync Input
3	+ Output
4	Output Return
5	- Output
6	Case Ground
7	Input Return
8	+ Input

Standard Microcircuit Drawing Equivalence

Standard Microcircuit Drawing Number	IR HiRel Standard Part Number
5962-05222	AMF2812D
5962-05223	AMF2815D

Device Screening

Requirement	MIL-STD-883 Method	No Suffix ②	CH ②	EM ③
Temperature Range	—	-55°C to +125°C	-55°C to +125°C	-55°C to +85°C
Element Evaluation	MIL-PRF-38534	Class H	Class H	N/A
Non-Destructive Bond Pull	2023	N/A	N/A	N/A
Internal Visual	2017	Yes	Yes	①
Temperature Cycle	1010	Cond C	Cond C	Cond C
Constant Acceleration	2001, Y1 Axis	3000 Gs	3000 Gs	3000 Gs
PIND	2020	Cond A	Cond A	N/A
Burn-In	1015	320 hrs @ 125°C (2 x 160 hrs)	320 hrs @ 125°C (2 x 160 hrs)	48 hrs @ 125°C
Final Electrical (Group A)	MIL-PRF-38534 & Specification	-55°C, +25°C, +125°C	-55°C, +25°C, +85°C	-55°C, +25°C, +85°C
PDA	MIL-PRF-38534	2%	2%	N/A
Seal, Fine and Gross	1014	Cond A, C	Cond A, C	Cond A
Radiographic	2012	Yes	Yes	N/A
External Visual	2009	Yes	Yes	①

Notes:

- ① Best commercial practice.
- ② Devices with "/CH" suffix is a DLA class H compliant without radiation performance. No suffix is a radiation rated device but not available as a DLA qualified SMD per MIL-PRF-38534.
- ③ Any Engineering Model (EM) build with the "EM" Suffix shall only be form, fit and functional equivalent to its Flight Model (FM) counterpart, and it may not meet the radiation performance. The EM Model shall not be expected comply with MIL-PRF-38534 flight quality/workmanship standards, and configuration control. An EM build may use electrical equivalent commercial grade components. IR HiRel will provide a list of non-compliance items upon request.

Part Numbering

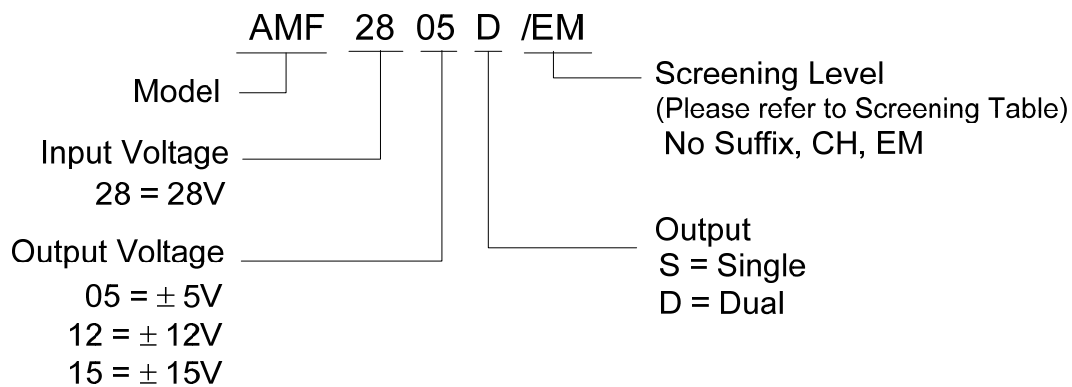

IMPORTANT NOTICE

The information given in this document shall be in no event regarded as guarantee of conditions or characteristic. The data contained herein is a characterization of the component based on internal standards and is intended to demonstrate and provide guidance for typical part performance. It will require further evaluation, qualification and analysis to determine suitability in the application environment to confirm compliance to your system requirements.

With respect to any example hints or any typical values stated herein and/or any information regarding the application of the product, Infineon Technologies hereby disclaims any and all warranties and liabilities of any kind including without limitation warranties on non- infringement of intellectual property rights and any third party.

In addition, any information given in this document is subject to customer's compliance with its obligations stated in this document and any applicable legal requirements, norms and standards concerning customer's product and any use of the product of Infineon Technologies in customer's applications.

The data contained in this document is exclusively intended for technically trained staff. It is the responsibility of any customer's technical departments to evaluate the suitability of the product for the intended applications and the completeness of the product information given in this document with respect to applications.

For further information on the product, technology, delivery terms and conditions and prices, please contact your local sales representative or go to (www.infineon.com/hirel).

WARNING

Due to technical requirements products may contain dangerous substances. For information on the types in question, please contact your nearest Infineon Technologies office.

单击下面可查看定价，库存，交付和生命周期等信息

[>>Infineon Technologies\(英飞凌\)](#)