

**EMI FILTER
HYBRID-HIGH RELIABILITY**

Description

The ARF Series EMI filter has been designed to provide full compliance with the input line reflected ripple current requirement specified by CE03 of MIL-STD-461C over the extended military temperature range while operating in conjunction with the corresponding ART and ARH Series of DC-DC converters. These filters are offered as part of a family of high reliability conversion products providing single, dual and triple output voltages while operating from nominal +28 volt input line. Other converters operating with a similar switching frequency will also benefit by use of this device.

These EMI filters are hermetically packaged in a seam welded enclosure utilizing axially oriented copper-core pins which minimize resistive DC losses. This package has been configured to complement the ART and ARH packages as a convenience in system installation and is fabricated with IR HiRel rugged ceramic lead-to-package seal assuring long term hermetic seal integrity in harsh environments.

Designed to meet the derating requirements of MIL-STD-975 and manufactured in a facility fully qualified to MIL-PRF-38534, these are available in two screening grades. The flight grade is designed, screened and processed for space as specified in MIL-PRF-38534 for Class K.



Features

- Up to 3.0 A Output Current
- Attenuation > 40dB @ 100 kHz
- Low Profile Seam Welded Package
- Ceramic Insulated Copper Core Pins
- Operation Over Full Military Temp. Range
- No Derating for -55°C to +125°C

The EM grade is processed and screened for lower grade requirement. Both grades are tested to meet the complete group "A" test specification over the full military temperature range with no derating. Variations in electrical, mechanical and screening requirements can be accommodated. Contact IR HiRel San Jose for special requirements.

Typical Connection Diagram

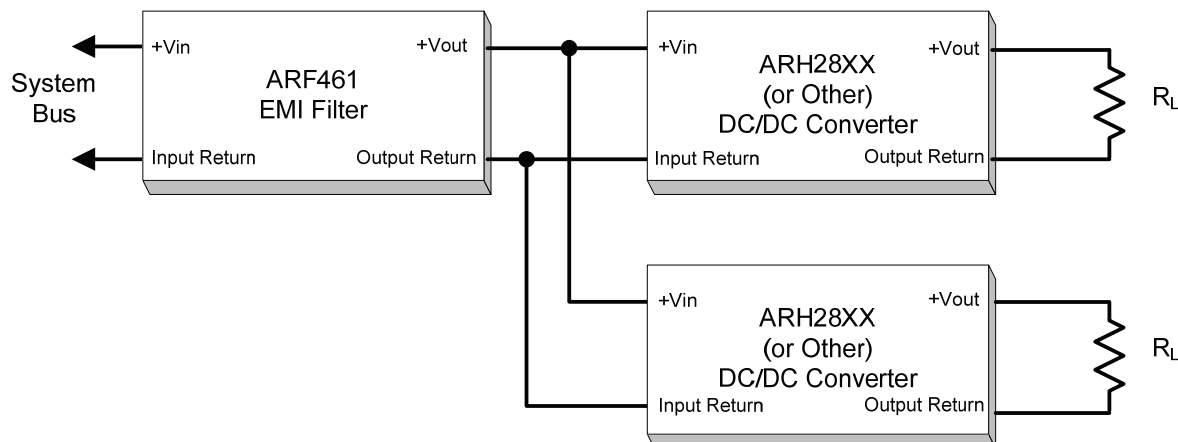

Specifications

Absolute Maximum Ratings, Note 1	
Input Voltage Range	-80V to +80V, Note 2
Input Current	5.0A
Lead Soldering Temperature	+300°C for 10 seconds
Case Temperature-Operating	-55°C to +125°C
Case Temperature-Storage	-65°C to +135°C

Electrical Performance Characteristics $-55^{\circ}\text{C} \leq T_{\text{CASE}} \leq +125^{\circ}\text{C}$, $0 \leq V_{\text{IN}} \leq +50\text{V}$ unless otherwise specified

Parameter	Group A Subgroup	Conditions	Min.	Nom.	Max.	Unit
Input Voltage		Steady State	-50	—	+50	V_{DC}
		Transient, Note 2	-80	—	+80	
Output Voltage	1, 2, 3	$V_{\text{OUT}} = V_{\text{IN}} - I_{\text{IN}} (R_{\text{DC}})$				V_{DC}
Output Current, Note 3			—	—	4.0	A_{DC}
DC Resistance, Note 4	1	$T_{\text{C}} = 25^{\circ}\text{C}$	—	—	240	$m\Omega$
Power Dissipation		Maximum Current, $T_{\text{C}} = 25^{\circ}\text{C}$	—	—	3.84	W
Noise Reduction		150 kHz - 50 MHz	40	—	—	dB
Isolation	1	Any Pin to Case, Tested @ $500V_{\text{DC}}$	100	—	—	$M\Omega$
Capacitance		Measured between any Pin and Case	14	—	22	nF
Device Weight		Slight variation with Case Style	—	95	—	g

Notes to Specifications

1. Operation above maximum ratings may cause permanent damage to the device. Operation at maximum ratings may degrade performance and affect reliability.
2. Device can tolerate ± 100 Volt transient whose duration is ≤ 100 ms when $R_{\text{S}} \geq 0.5 \Omega$.
3. Derate Output Current linearly from 100% at 125°C to 0% at 135°C .
4. DC resistance is the total resistance of the device and includes the sum of the input to output resistance and the *return in* to *return out* resistance paths.

Mechanical Outline

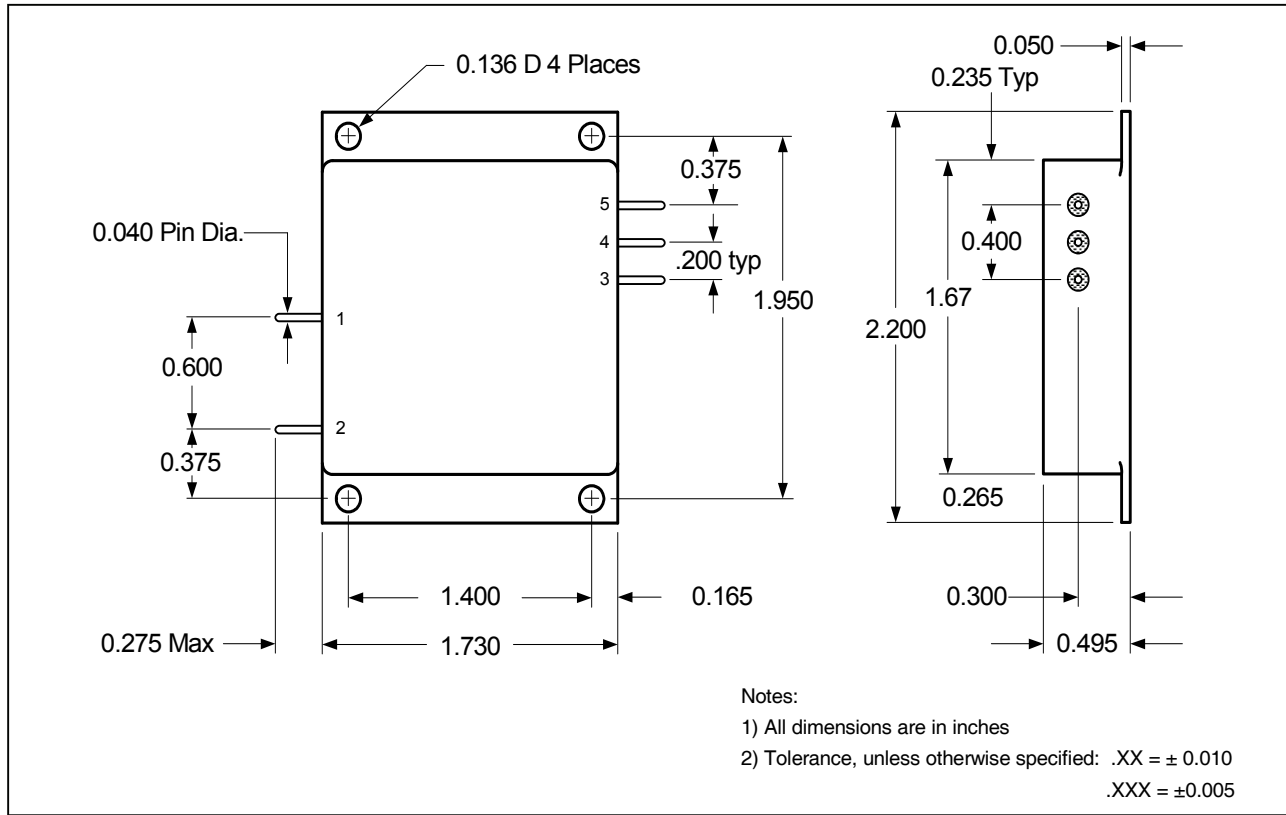

Block Diagram

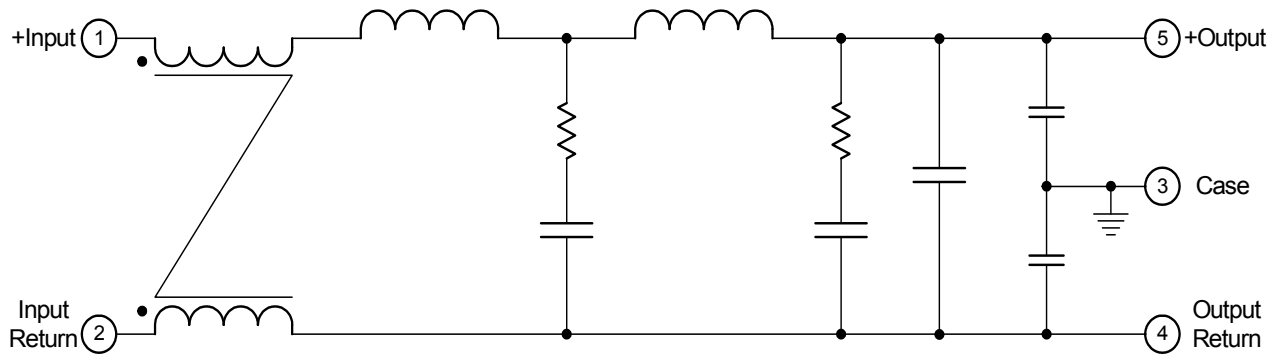

Pin Designation

Pin #	Designation
1	+ Input
2	Input Return
3	Case Ground
4	Output Return
5	+ Output

Note: Input and Output Returns are internally connected

Device Screening

Requirement	MIL-STD-883 Method	Flight No Suffix	/EM Suffix ①
Temperature Range	—	-55°C to +125°C	-55°C to +125°C
Element Evaluation	—	MIL-PRF-38534, Class K	—
Internal Visual	2017	—	—
Temperature Cycle	1010	Cond C	Cond C
Constant Acceleration	2001	3000g	500g
PIND	2020	Cond A	—
Burn-in Interim Electrical @ 160 hrs	1015	320 hrs @ 125°C (2 x160hrs)	48 hrs @ 125°C
Final Electrical (Group A) Read & Record Data	MIL-PRF-38534 & Specification	-55°C, +25°C, +125°C	-55°C, +25°C, +125°C
PDA (25°C, interim to final)	—	2%	—
Seal, Fine & Gross	1014	Cond A, C	Cond A, C
Radiographic Inspection	2012	YES	—
External Visual	2009	YES	YES

Note:

① Any Engineering Model (EM) build with the “EM” Suffix shall only be form, fit and functional equivalent to its Flight Model (FM) counterpart, and it may not meet the radiation performance. The EM Model shall not be expected comply with MIL-PRF-38534 flight quality/workmanship standards, and configuration control. An EM build may use electrical equivalent commercial grade components. IR HiRel will provide a list of non-compliance items upon request.

Part Numbering

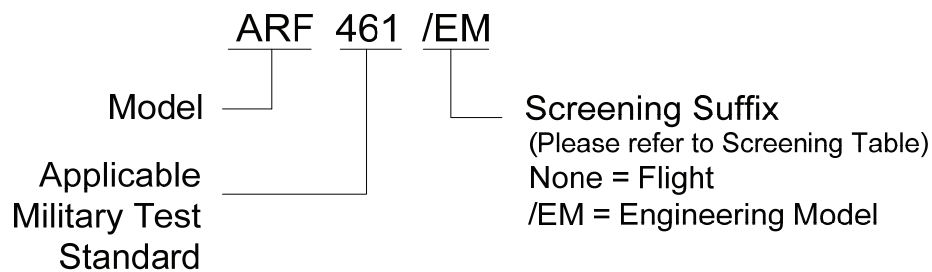

IMPORTANT NOTICE

The information given in this document shall be in no event regarded as guarantee of conditions or characteristic. The data contained herein is a characterization of the component based on internal standards and is intended to demonstrate and provide guidance for typical part performance. It will require further evaluation, qualification and analysis to determine suitability in the application environment to confirm compliance to your system requirements.

With respect to any example hints or any typical values stated herein and/or any information regarding the application of the product, Infineon Technologies hereby disclaims any and all warranties and liabilities of any kind including without limitation warranties on non- infringement of intellectual property rights and any third party.

In addition, any information given in this document is subject to customer's compliance with its obligations stated in this document and any applicable legal requirements, norms and standards concerning customer's product and any use of the product of Infineon Technologies in customer's applications.

The data contained in this document is exclusively intended for technically trained staff. It is the responsibility of any customer's technical departments to evaluate the suitability of the product for the intended applications and the completeness of the product information given in this document with respect to applications.

For further information on the product, technology, delivery terms and conditions and prices, please contact your local sales representative or go to (www.infineon.com/hirel).

WARNING

Due to technical requirements products may contain dangerous substances. For information on the types in question, please contact your nearest Infineon Technologies office.

单击下面可查看定价，库存，交付和生命周期等信息

[>>Infineon Technologies\(英飞凌\)](#)