

IV2Q12080D7Z – 1200V 80mΩ Gen2 Automotive SiC MOSFET

Features

- 2nd Generation SiC MOSFET Technology with +15V~+18V gate drive
- High blocking voltage with low on-resistance
- High speed switching with low capacitance
- 175°C operating junction temperature capability
- Ultra fast and robust intrinsic body diode
- Kelvin gate input easing driver circuit design
- AEC-Q101 qualified

Applications

- EV chargers and OBCs
- Solar boosters
- Automotive compressor inverters
- AC/DC power supplies

Outline:

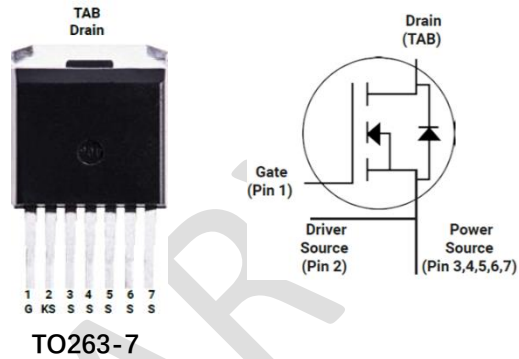

Marking Diagram:

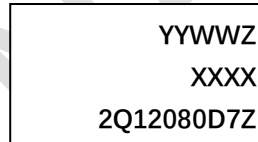

2Q12080D7Z = Specific Device Code
 YY = Year
 WW = Work Week
 Z = Assembly Location
 XXXX = Lot Traceability

Absolute Maximum Ratings (T_c=25°C unless otherwise specified)

Symbol	Parameter	Value	Unit	Test Conditions	Note
V _{DS}	Drain-Source voltage	1200	V	V _{GS} =0V, I _D =100μA	
V _{GSmax} (Transient)	Maximum transient voltage	-10 to 23	V	Duty cycle<1%, and pulse width<200ns	
V _{GSon}	Recommended turn-on voltage	15 to 18	V		
V _{GSoff}	Recommended turn-off voltage	-5 to -2	V	Typical -3.5V	
I _D	Drain current (continuous)	41	A	V _{GS} =18V, T _c =25°C	Fig. 23
		29	A	V _{GS} =18V, T _c =100°C	
I _{DM}	Drain current (pulsed)	102	A	Pulse width limited by SOA and dynamic R _{θ(j-c)}	Fig.25, 26
I _{SM}	Body diode current (pulsed)	102	A	Pulse width limited by SOA and dynamic R _{θ(j-c)}	Fig.25, 26
P _{TOT}	Total power dissipation	250	W	T _c =25°C	Fig. 24
T _{stg}	Storage temperature range	-55 to 175	°C		
T _J	Operating junction temperature	-55 to 175	°C		
T _L	Solder Temperature	260	°C	wave soldering only allowed at leads, 1.6mm from case for 10 s	

Thermal Data

Symbol	Parameter	Value	Unit	Note
R _{θ(j-c)}	Thermal Resistance from Junction to Case	0.6	°C/W	Fig. 25

Electrical Characteristics ($T_c=25^\circ\text{C}$ unless otherwise specified)

Symbol	Parameter	Value			Unit	Test Conditions	Note
		Min.	Typ.	Max.			
I_{DSS}	Zero gate voltage drain current		5	100	μA	$V_{DS}=1200\text{V}, V_{GS}=0\text{V}$	
I_{GSS}	Gate leakage current			± 100	nA	$V_{DS}=0\text{V}, V_{GS}=-5\sim 20\text{V}$	
V_{TH}	Gate threshold voltage	1.8	2.9	4.5	V	$V_{GS}=V_{DS}, I_D=5\text{mA}$	Fig. 8, 9
			2.0			$V_{GS}=V_{DS}, I_D=5\text{mA}$ @ $T_J=175^\circ\text{C}$	
R_{ON}	Static drain-source on-resistance		80	104	$\text{m}\Omega$	$V_{GS}=18\text{V}, I_D=10\text{A}$ @ $T_J=25^\circ\text{C}$	Fig. 4, 5, 6, 7
			136		$\text{m}\Omega$	$V_{GS}=18\text{V}, I_D=10\text{A}$ @ $T_J=175^\circ\text{C}$	
			100		$\text{m}\Omega$	$V_{GS}=15\text{V}, I_D=10\text{A}$ @ $T_J=25^\circ\text{C}$	
			145		$\text{m}\Omega$	$V_{GS}=15\text{V}, I_D=10\text{A}$ @ $T_J=175^\circ\text{C}$	
C_{iss}	Input capacitance		1214		pF	$V_{DS}=800\text{V}, V_{GS}=0\text{V},$ $f=1\text{MHz}, V_{AC}=25\text{mV}$	Fig. 16
C_{oss}	Output capacitance		58.1		pF		
C_{rss}	Reverse transfer capacitance		4.2		pF		
E_{oss}	C_{oss} stored energy		25		μJ		Fig. 17
Q_g	Total gate charge		53		nC	$V_{DS}=800\text{V}, I_D=20\text{A},$ $V_{GS}=-3\text{ to }18\text{V}$	Fig. 18
Q_{gs}	Gate-source charge		14		nC		
Q_{gd}	Gate-drain charge		24		nC		
R_g	Gate input resistance		4.2		Ω	$f=1\text{MHz}$	
E_{ON}	Turn-on switching energy		291		μJ	$V_{DS}=800\text{V}, I_D=20\text{A},$ $V_{GS}=-3.5\text{ to }18\text{V},$ $R_{G(\text{ext})}=3.3\Omega,$ $L=200\mu\text{H}$ $T_J=25^\circ\text{C}$	Fig. 19, 20
E_{OFF}	Turn-off switching energy		41.8		μJ		
$t_{d(\text{on})}$	Turn-on delay time		2.8		ns		
t_r	Rise time		14				
$t_{d(\text{off})}$	Turn-off delay time		12.4				
t_f	Fall time		9.6				
E_{ON}	Turn-on switching energy		568		μJ	$V_{DS}=800\text{V}, I_D=20\text{A},$ $V_{GS}=-3.5\text{ to }18\text{V},$ $R_{G(\text{ext})}=3.3\Omega, L=200\mu\text{H}$ $T_J=175^\circ\text{C}$	Fig. 22
E_{OFF}	Turn-off switching energy		47		μJ		

Reverse Diode Characteristics ($T_c=25^\circ\text{C}$ unless otherwise specified)

Symbol	Parameter	Value			Unit	Test Conditions	Note
		Min.	Typ.	Max.			
V_{SD}	Diode forward voltage		4.0		V	$I_{SD}=10\text{A}, V_{GS}=0\text{V}$	Fig. 10, 11, 12
			3.8		V	$I_{SD}=10\text{A}, V_{GS}=0\text{V}, T_J=175^\circ\text{C}$	
I_S	Diode forward current (continuous)			41	A	$V_{GS}=-2\text{V}, T_c=25^\circ\text{C}$	
				24	A	$V_{GS}=-2\text{V}, T_c=100^\circ\text{C}$	
t_{rr}	Reverse recovery time		42		ns	$V_{GS}=-3.5\text{V}/+18\text{V}, I_{SD}=20\text{A}, V_R=800\text{V}, R_{G(\text{ext})}=8.9\Omega, L=200\mu\text{H}, \text{di}/\text{dt}=3000\text{A}/\mu\text{s}$	
Q_{rr}	Reverse recovery charge		138.4		nC		
I_{RRM}	Peak reverse recovery current		12.4		A		

Typical Performance (curves)

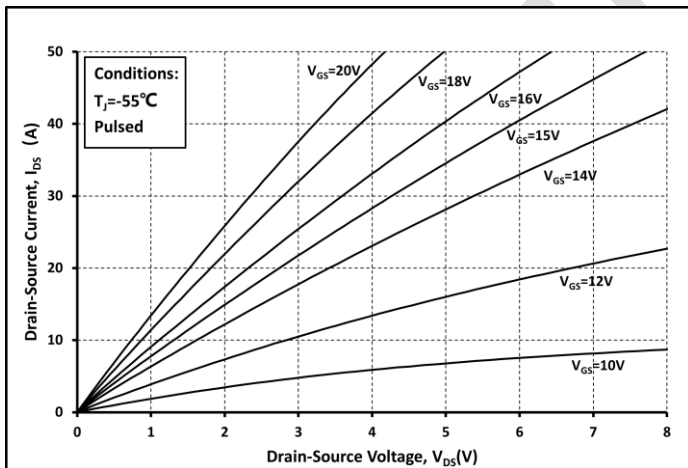

Fig. 1 Output Curve @ $T_J=-55^\circ\text{C}$

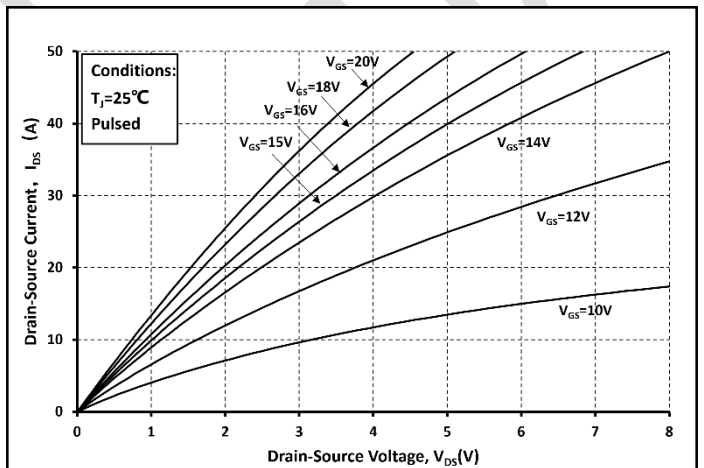

Fig. 2 Output Curve @ $T_J=25^\circ\text{C}$

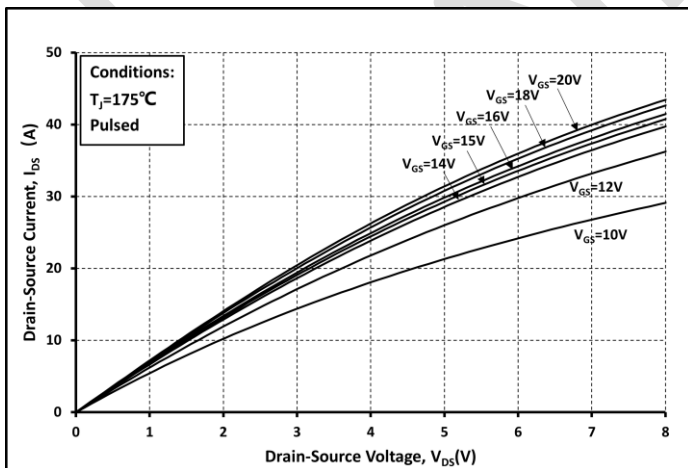

Fig. 3 Output Curve @ $T_J=175^\circ\text{C}$

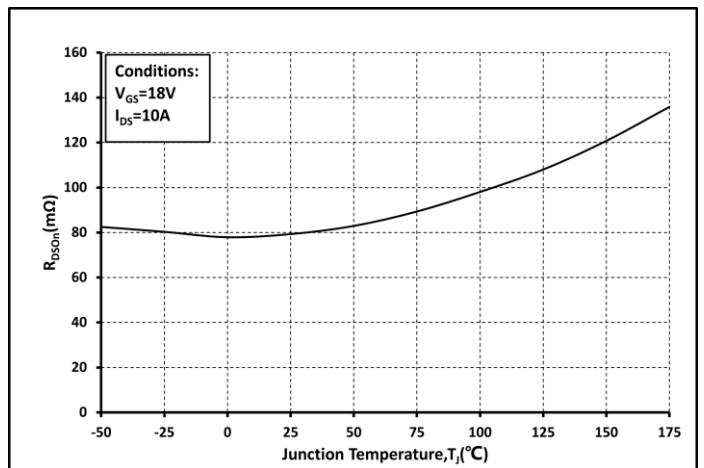

Fig. 4 R_{on} vs. Temperature

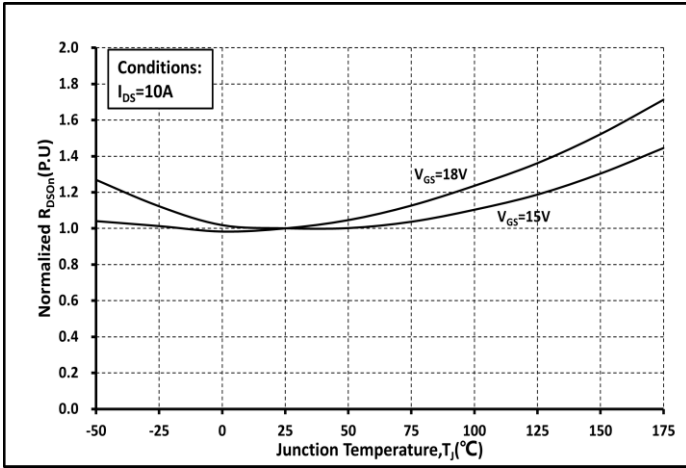

Fig. 5 Normalized Ron vs. Temperature

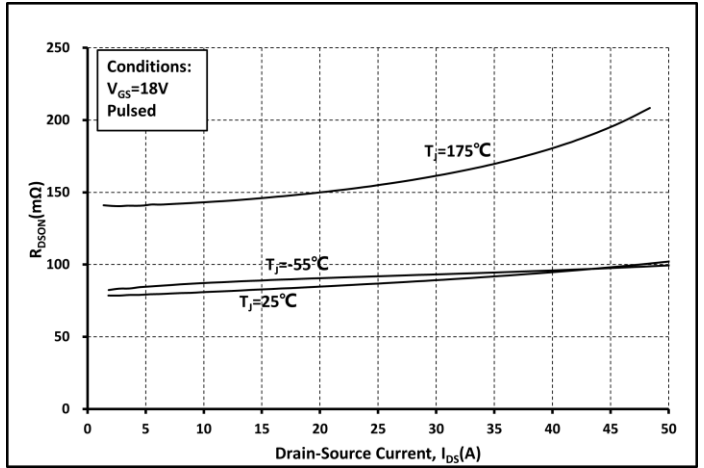

Fig. 6 Ron vs. I_DS @ Various Temperature

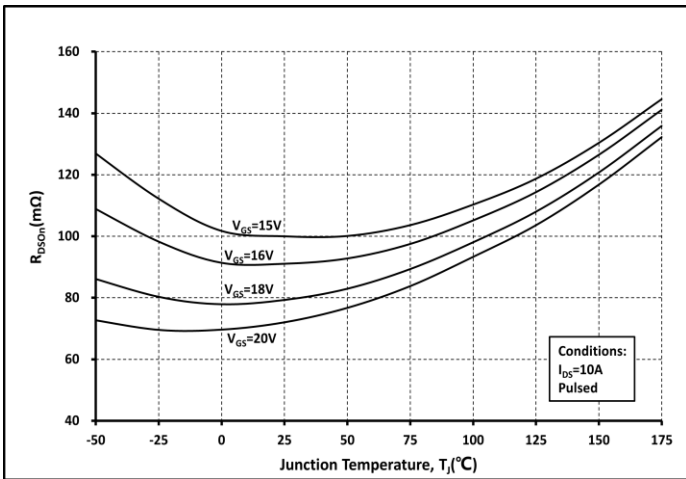

Fig. 7 Ron vs. Temperature @ Various V_GS

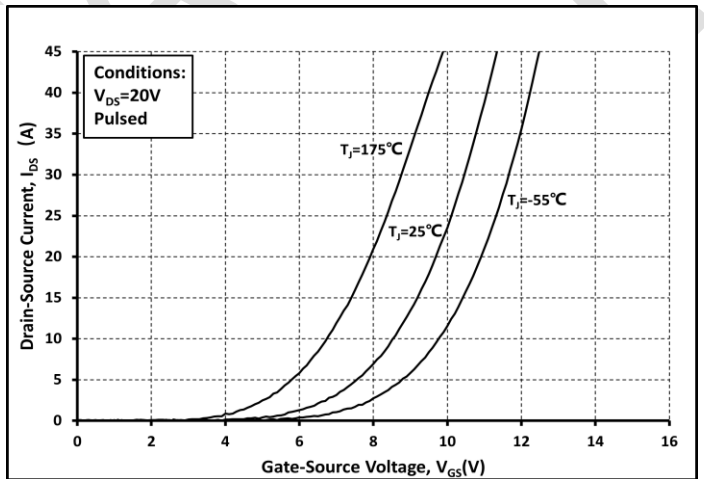

Fig. 8 Transfer Curves @ Various Temperature

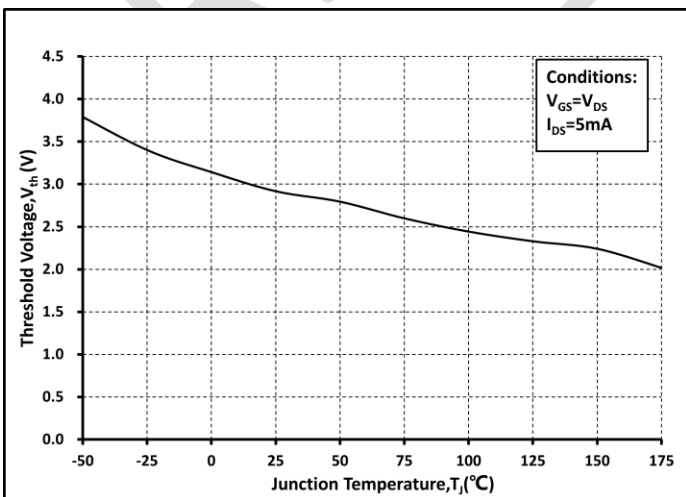

Fig. 9 Threshold Voltage vs. Temperature

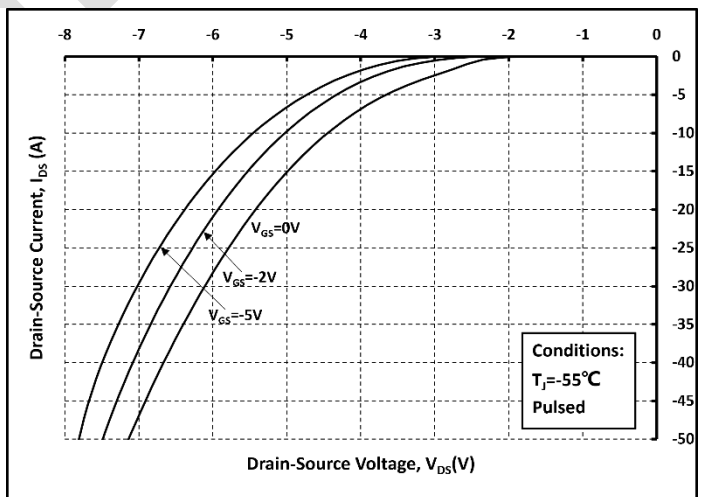

Fig. 10 Body Diode curves @ T_J = -55°C

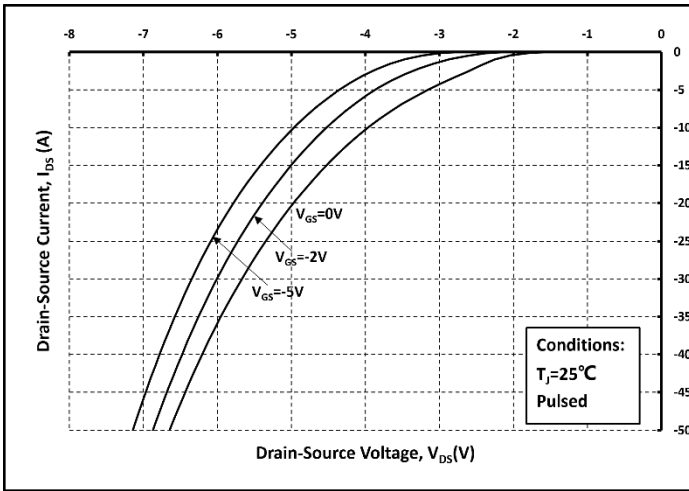

Fig. 11 Body Diode curves @ $T_j=25^\circ\text{C}$

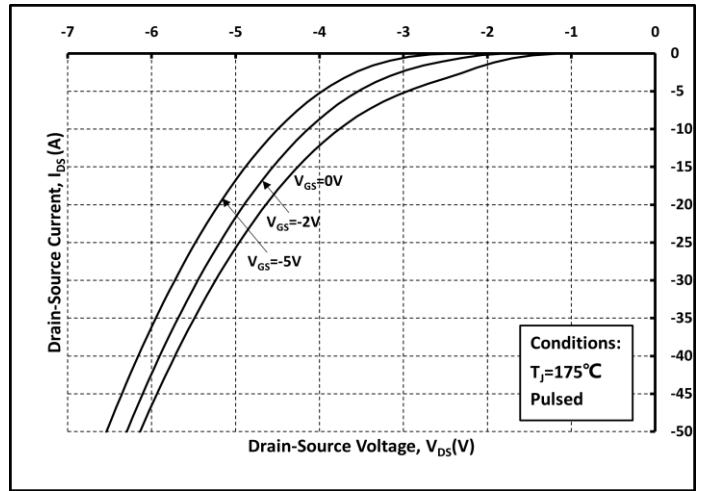

Fig. 12 Body Diode curves @ $T_j=175^\circ\text{C}$

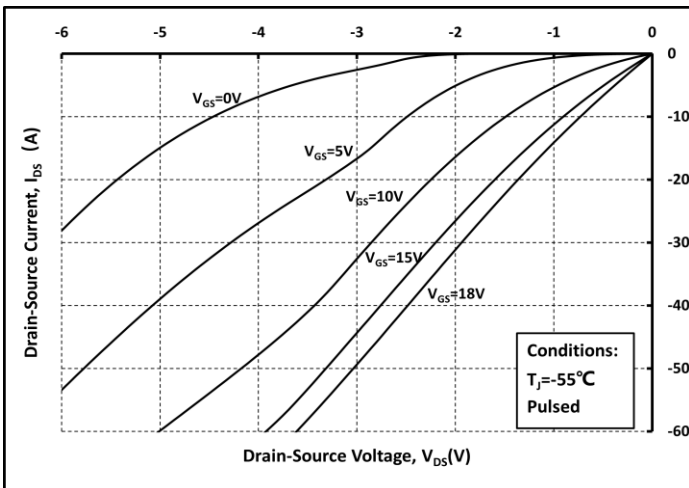

Fig. 13 3rd Quadrant curves @ $T_j=-55^\circ\text{C}$

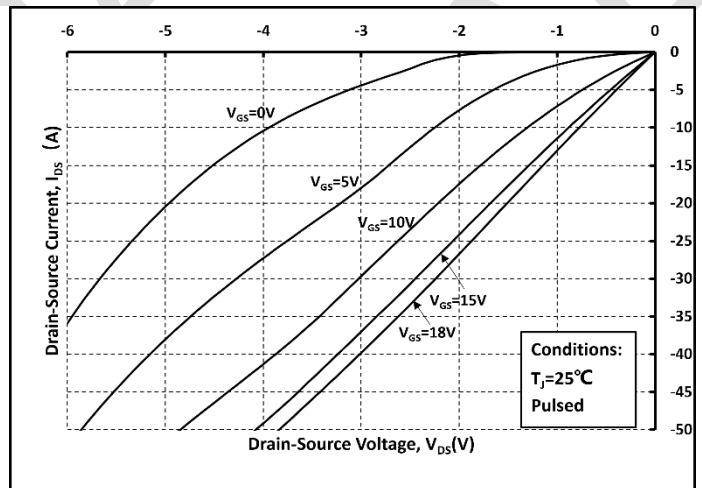

Fig. 14 3rd Quadrant curves @ $T_j=25^\circ\text{C}$

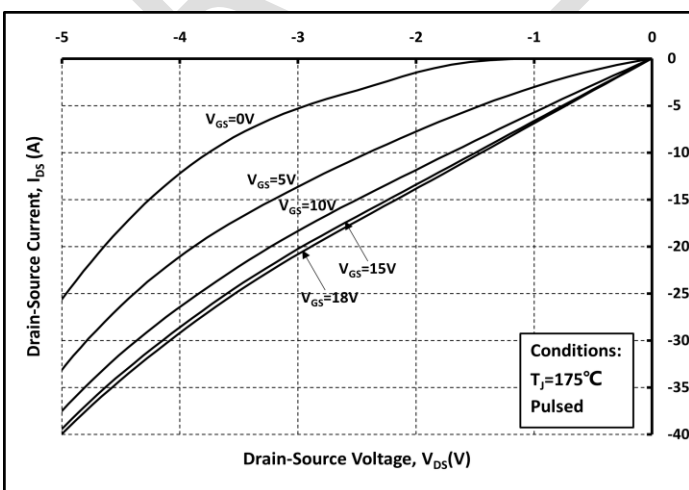

Fig. 15 3rd Quadrant curves @ $T_j=175^\circ\text{C}$

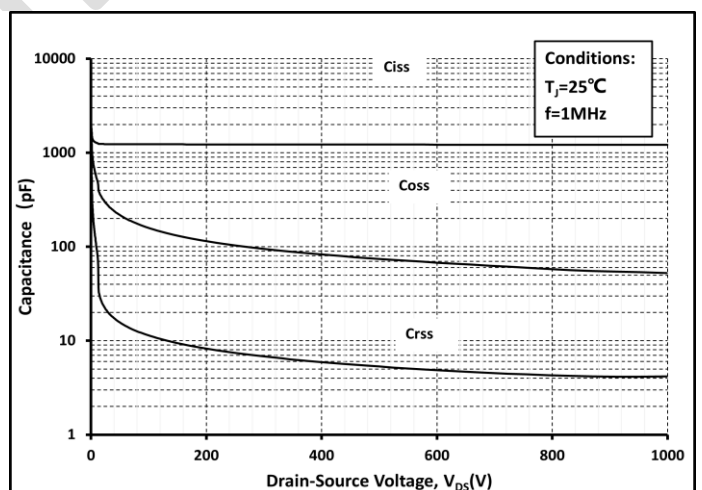

Fig. 16 Capacitance vs. V_{DS}

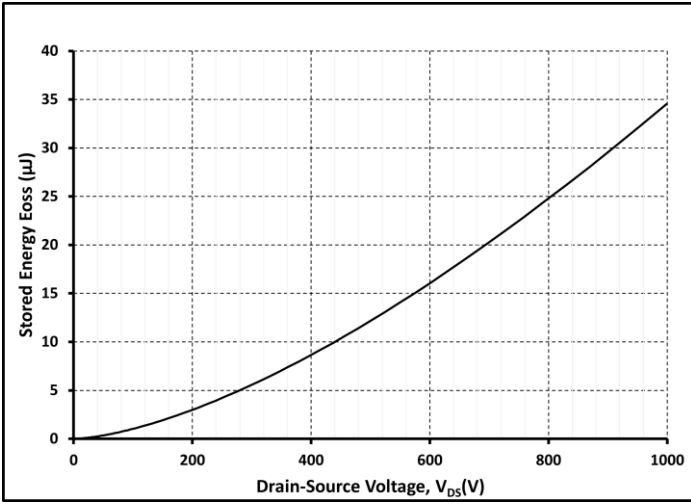

Fig. 17 Output Capacitor Stored Energy

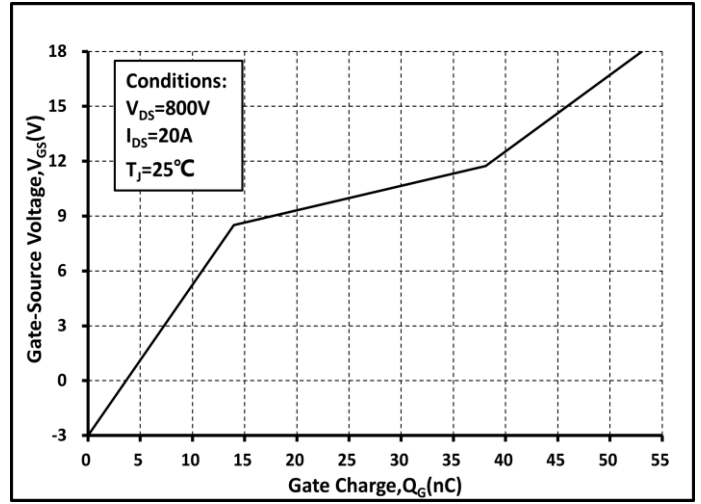

Fig. 18 Gate Charge Characteristics

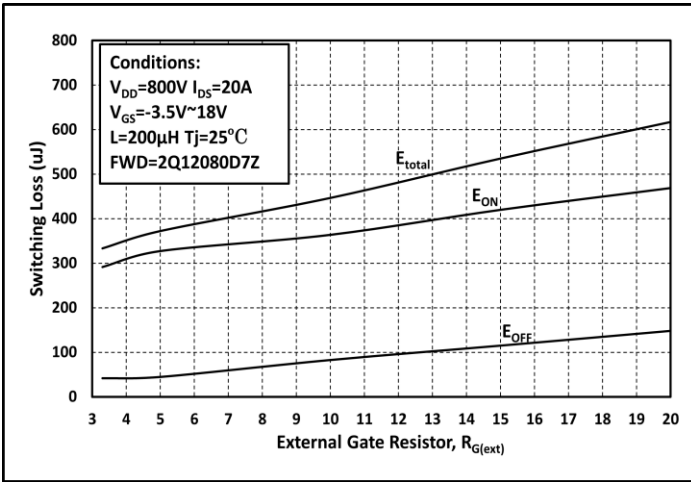

Fig. 19 Switching Energy vs. $R_{G(ext)}$

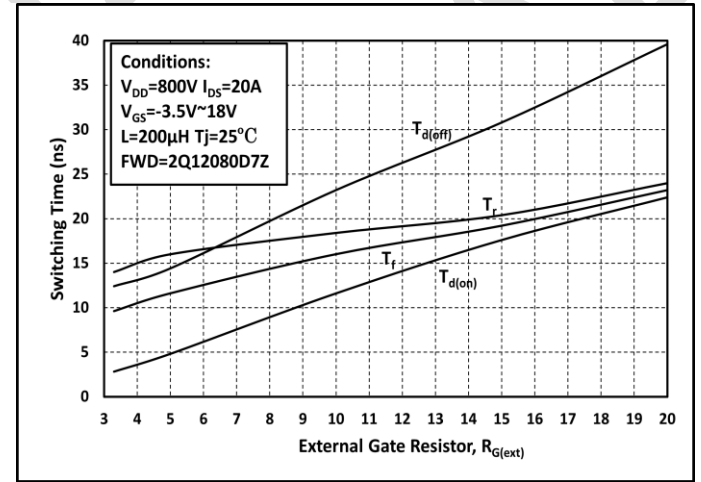

Fig. 20 Switching Times vs. $R_{G(ext)}$

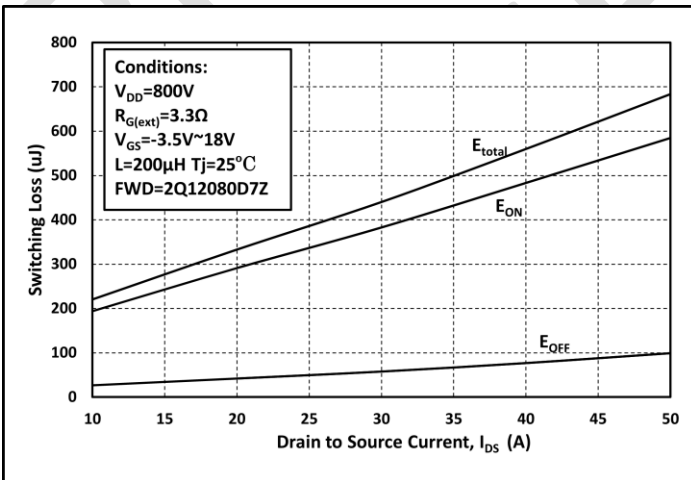

Fig. 21 Switching Energy vs. I_{DS}

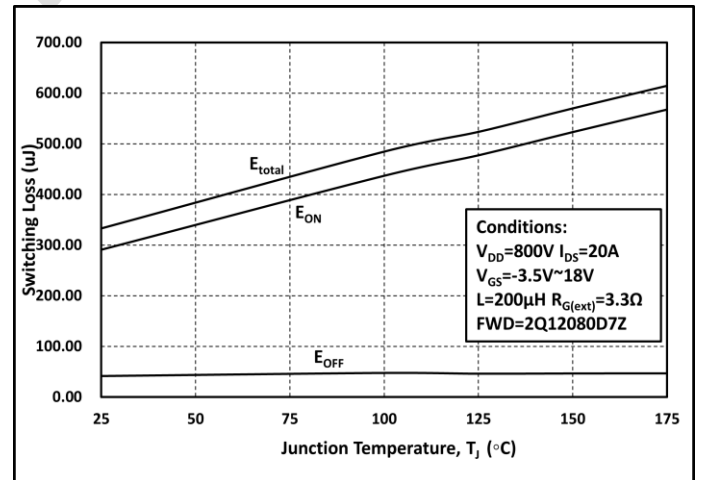

Fig. 22 Switching Energy vs. Temperature

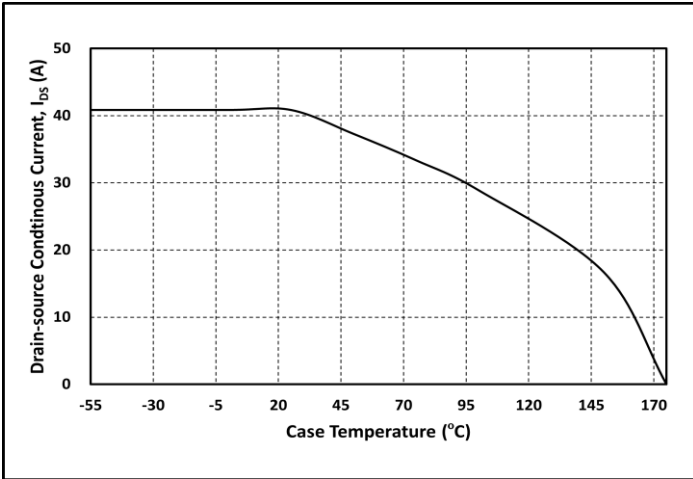

Fig. 23 Continuous Drain Current vs. Case Temperature

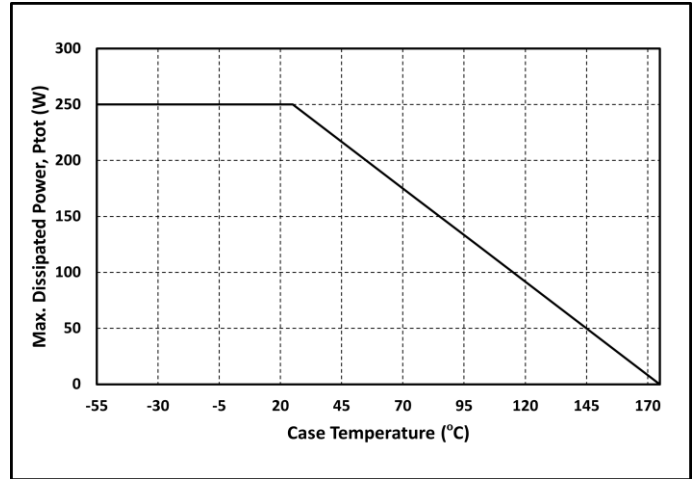

Fig. 24 Max. Power Dissipation Derating vs. Case Temperature

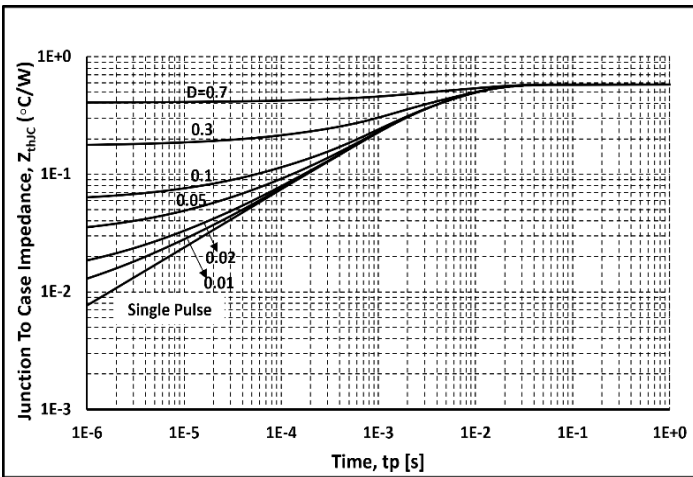

Fig. 25 Thermal impedance

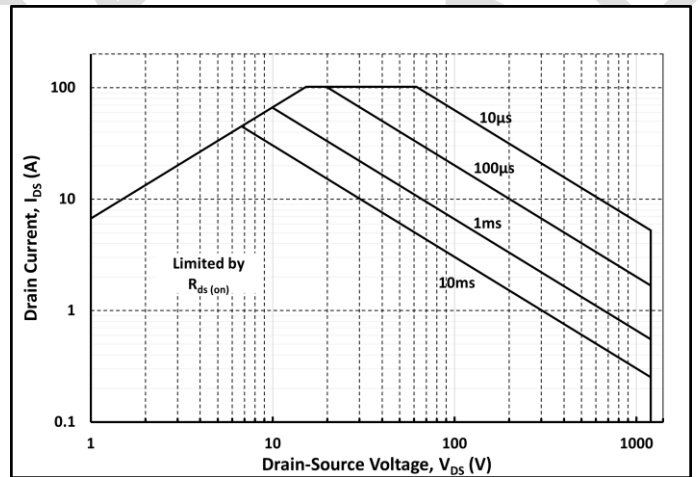
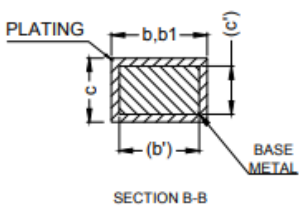
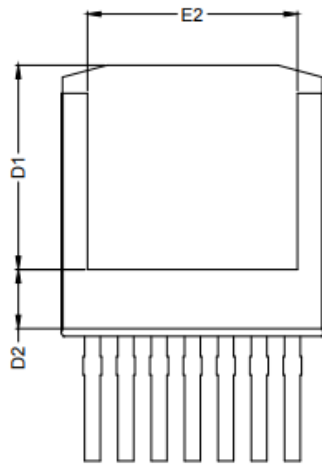
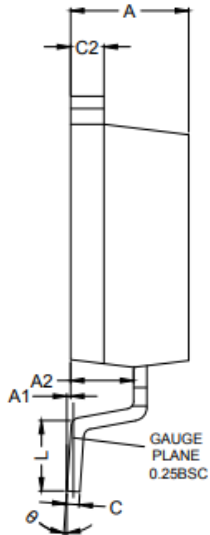
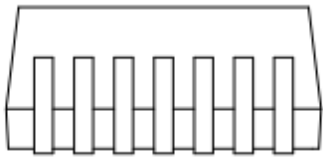
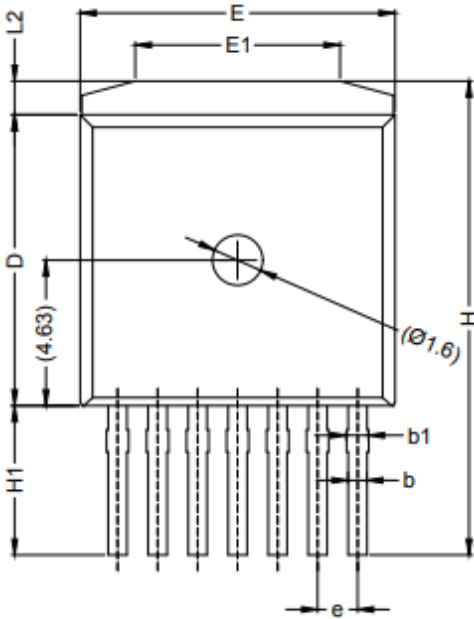

Fig. 26 Safe Operating Area

Package Dimensions



Items	Min	Max
A	4.30	4.70
A1	-	0.25
A2	2.20	2.60
b	0.52	0.72
b'	0.50	0.70
b1	0.60	0.80
c	0.42	0.62
c'	0.40	0.60
c2	1.07	1.47
D	9.05	9.45
D1	7.58	7.98
D2	2.05	2.45
e	1.27 BSC	
E	9.80	10.20
E1	6.30	6.70
E2	7.80	8.20
L	2.48	2.88
L2	0.87	1.27
H	14.87	15.27
H1	4.55	4.95
θ	0°	8°

Note:

1. Package Reference: JEDEC TO263, Variation AD
2. All Dimensions are in mm
3. Subject to Change Without Notice

Notes

For further information please contact IVCT's office.

Copyright©2024 InventChip Technology Co., Ltd. All rights reserved.

The Information in this document is subject to change without notice.

Related Links

<http://www.inventchip.com.cn>



PRELIMINARY
CONFIDENTIAL

单击下面可查看定价，库存，交付和生命周期等信息

[>>Inventchip\(瞻芯电子\)](#)