



## ISP817, ISP827, ISP847



### DESCRIPTION

The ISP817, ISP827 and ISP847 series of optically coupled isolator consist of an infrared light emitting diode and an NPN silicon photo transistor in a space efficient Dual In Line Plastic Package.

### FEATURES

- AC Isolation Voltage 5000V<sub>RMS</sub>
- CTR Selections Available
- Wide Operating Temperature Range  
-55°C to +110°C ISP817  
-40°C to +105°C ISP827 / ISP847
- RoHS Compliant
- UL File E91231 Package Code "EE"
- VDE Approval Certificate No. 40028086

### APPLICATIONS

- Computer Terminals
- Industrial System Controllers
- Measuring Instruments
- Signal Transmission between Systems of Different Potentials and Impedances

### ORDER INFORMATION

- Add X after PN for VDE Approval
- Add G after PN for 10mm lead spacing
- Add SM after PN for Surface Mount
- Add SMT&R after PN for Surface Mount Tape & Reel  
(Available for ISP817SM and ISP827SM)
- Consult Factory for Tape and Reel version of ISP847SM

#### ISP817

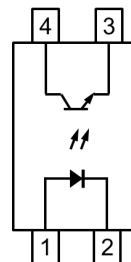

- 1 Anode
- 2 Cathode
- 3 Emitter
- 4 Collector

#### ISP827

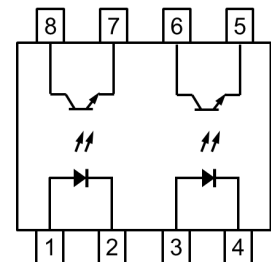

- 1, 3 Anode
- 2, 4 Cathode
- 5, 7 Emitter
- 6, 8 Collector

#### ISP847

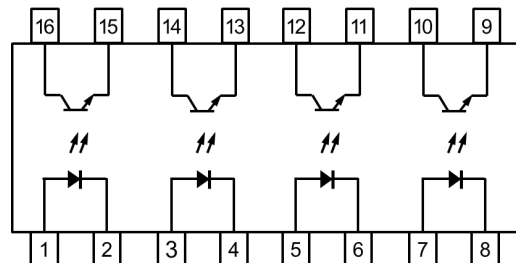

- 1, 3, 5, 7 Anode
- 2, 4, 6, 8 Cathode
- 9, 11, 13, 15 Emitter
- 10, 12, 14, 16 Collector

#### ISOCOM COMPONENTS 2004 LTD

Unit 25B, Park View Road West, Park View Industrial Estate  
Hartlepool, Cleveland, TS25 1PE, United Kingdom  
Tel : +44 (0)1429 863 609 Fax : +44 (0)1429 863 581  
e-mail : sales@isocom.co.uk  
<http://www.isocom.com>

#### ISOCOM COMPONENTS ASIA LTD

Hong Kong Office  
Block A, 8/F, Wah Hing Industrial Mansion  
36 Tai Yau Street, San Po Kong, Kowloon, Hong Kong  
Tel : +852 2995 9217 Fax : +852 8161 6292  
e-mail : sales@isocom.com.hk

## ISP817, ISP827, ISP847

### ABSOLUTE MAXIMUM RATINGS ( $T_A = 25^\circ\text{C}$ )

Stresses exceeding the absolute maximum ratings can cause permanent damage to the device.  
 Exposure to absolute maximum ratings for long periods of time can adversely affect reliability.

#### Input

Forward Current	50mA
Peak Forward Current (100 $\mu$ s, 100Hz)	1A
Reverse Voltage	6V
Power dissipation	70mW
Junction Temperature	125 °C

#### Output

Collector to Emitter Voltage $V_{CE0}$	
	ISP817 80V
	ISP827 / ISP847 35V
Emitter to Collector Voltage $V_{ECO}$	6V
Collector Current	50mA
Power Dissipation	150mW
Junction Temperature	125 °C

#### Total Package

Isolation Voltage	5000V <sub>RMS</sub>
Total Power Dissipation	200mW
Operating Temperature	ISP817 -55 to 110 °C
	ISP827 / ISP847 -40 to 105 °C
Storage Temperature	-55 to 125 °C
Lead Soldering Temperature (10s)	260°C

#### ISOCOM COMPONENTS 2004 LTD

Unit 25B, Park View Road West, Park View Industrial Estate  
 Hartlepool, Cleveland, TS25 1PE, United Kingdom  
 Tel : +44 (0)1429 863 609 Fax : +44 (0)1429 863 581  
 e-mail : sales@isocom.co.uk  
<http://www.isocom.com>

#### ISOCOM COMPONENTS ASIA LTD

Hong Kong Office  
 Block A, 8/F, Wah Hing Industrial Mansion  
 36 Tai Yau Street, San Po Kong, Kowloon, Hong Kong  
 Tel : +852 2995 9217 Fax : +852 8161 6292  
 e-mail : sales@isocom.com.hk

## ISP817, ISP827, ISP847

### ELECTRICAL CHARACTERISTICS (Ambient Temperature = 25°C unless otherwise specified)

#### INPUT

Parameter	Symbol	Test Condition	Min	Typ.	Max	Unit
Forward Voltage	$V_F$	$I_F = 20\text{mA}$		1.2	1.4	V
Reverse Leakage	$I_R$	$V_R = 4\text{V}$			10	$\mu\text{A}$
Terminal Capacitance	$C_t$	$V = 0\text{V}, f = 1\text{KHz}$		30	250	pF

#### OUTPUT

Parameter	Symbol	Test Condition	Min	Typ.	Max	Unit
Collector–Emitter Breakdown Voltage	$BV_{CEO}$	$I_C = 0.1\text{mA}, I_F = 0\text{mA}$				V
		ISP817	80			
		ISP827 / ISP847	35			
Emitter–Collector Breakdown Voltage	$BV_{ECO}$	$I_E = 10\mu\text{A}, I_F = 0\text{mA}$	6			V
Collector–Emitter Dark Current	$I_{CEO}$	$V_{CE} = 20\text{V}, I_F = 0\text{mA}$			100	nA



**ISP817, ISP827, ISP847**

**ELECTRICAL CHARACTERISTICS (Ambient Temperature = 25°C unless otherwise specified)**

**COUPLED**

Parameter	Symbol	Test Condition	Min	Typ.	Max	Unit
Current Transfer Ratio	CTR	$I_F = 5\text{mA}, V_{CE} = 5\text{V}$	50		600	%
		Optional CTR Grades				
		GB	100		600	
		BL	200		600	
		GR	100		300	
		A	80		160	
		B	130		260	
		C	200		400	
D	300		600			
Collector-Emitter Saturation Voltage	$V_{CE(sat)}$	$I_F = 20\text{mA}, I_C = 1\text{mA}$		0.1	0.2	V
Floating Capacitance	$C_f$	$V = 0\text{V}, f = 1\text{MHz}$		0.6	1	pF
Cut-Off Frequency	$f_c$	$V_{CE} = 5\text{V}, I_C = 2\text{mA}$ $R_L = 100\Omega$ -3dB		80		kHz
Output Rise Time	$t_r$	$V_{CC} = 5\text{V}$ $I_C = 2\text{mA}$ $R_L = 100\Omega$		4	18	$\mu\text{s}$
Output Fall Time	$t_f$			3	18	

**ISOLATION**

Parameter	Symbol	Test Condition	Min	Typ.	Max	Unit
Input to Output Isolation Voltage	$V_{ISO}$	AC 1 minute, RH = 40% to 60%	5000			$V_{RMS}$
Input to Output Isolation Resistance	$R_{ISO}$	$V_{IO} = 500\text{VDC}$ RH = 40% to 60%	$5 \times 10^{10}$	$1 \times 10^{11}$		$\Omega$

Measure with input leads shorted together and output leads shorted together.



## ISP817, ISP827, ISP847

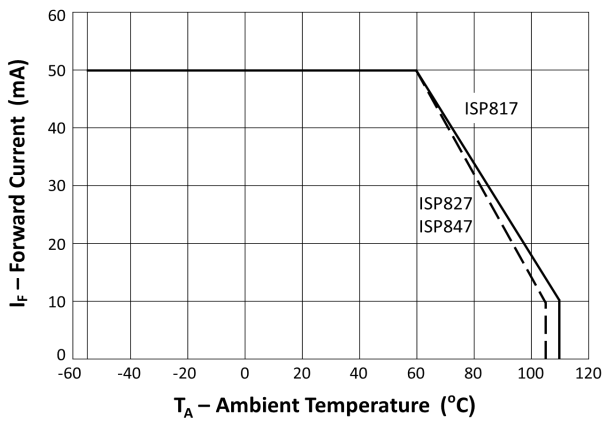

Fig 1 Forward Current vs Ambient Temperature

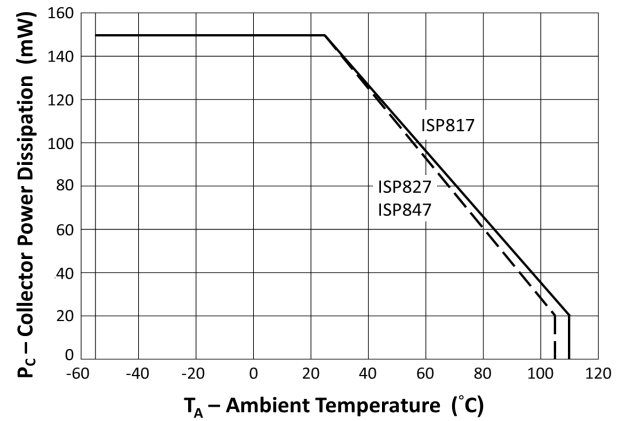

Fig 2 Collector Power Dissipation vs Ambient Temperature

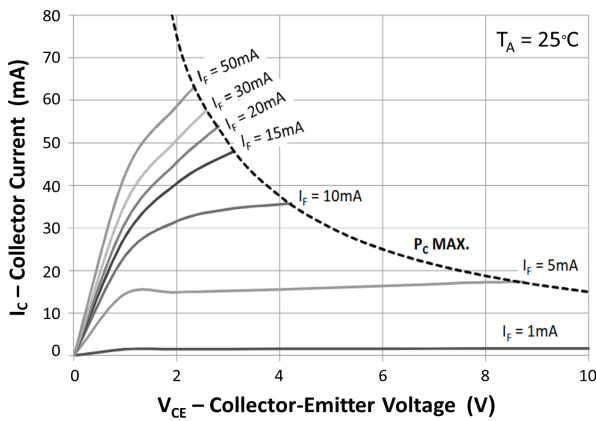

Fig 3 Collector Current vs Collector-Emitter Voltage (1)

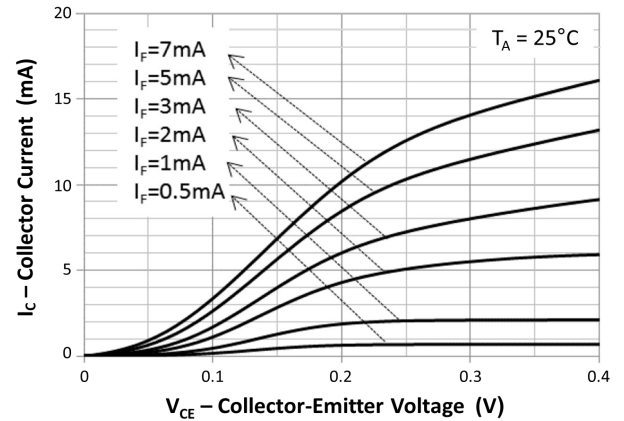

Fig 4 Collector Current vs Collector-Emitter Voltage (2)

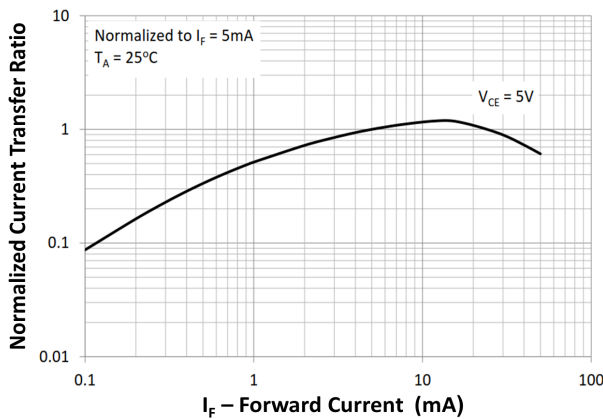

Fig 5 Normalized Current Transfer Ratio vs Forward Current

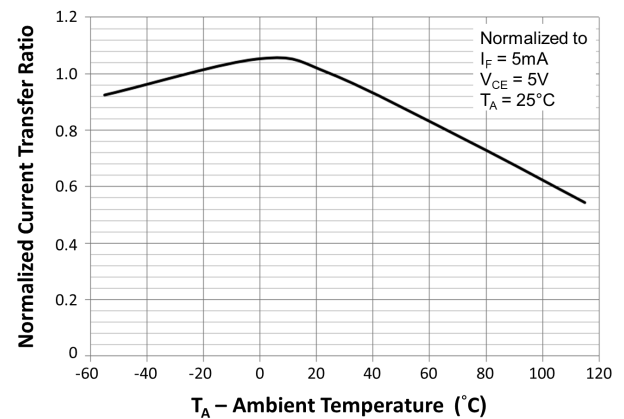
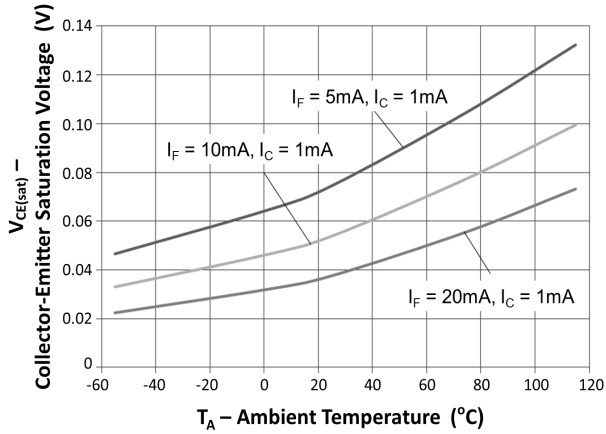

Fig 6 Normalized Current Transfer Ratio vs Ambient Temperature



## ISP817, ISP827, ISP847



**Fig 7 Collector-Emitter Saturation Voltage vs Ambient Temperature**

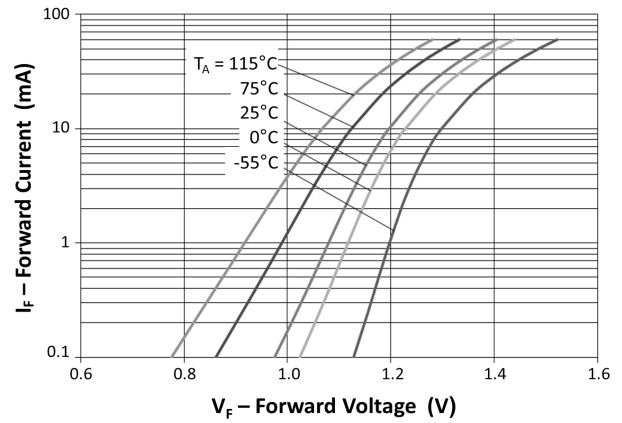

**Fig 8 Forward Current vs Forward Voltage**

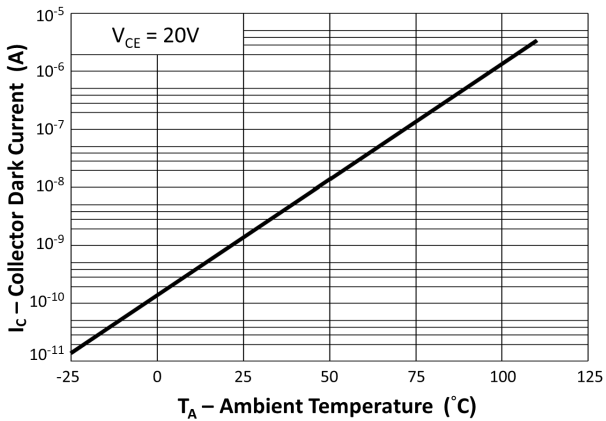

**Fig 9 Collector Dark Current vs Ambient Temperature**

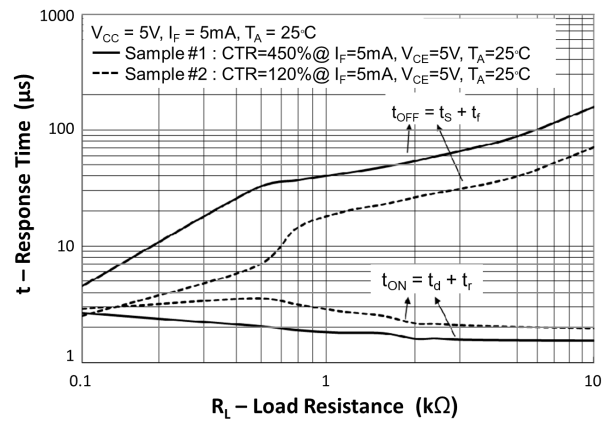

**Fig 10 Switching Time vs Load Resistance**

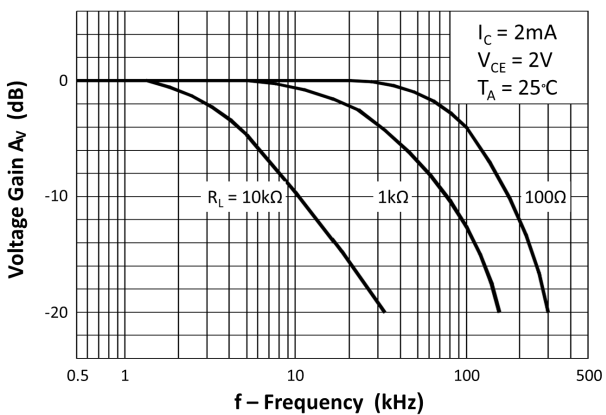

**Fig 11 Frequency Response**

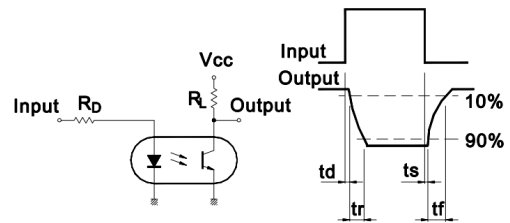

**Response Time Test Circuit**

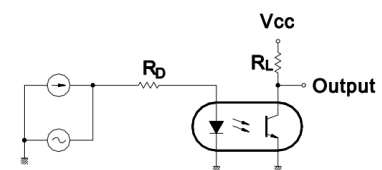

**Frequency Response Test Circuit**



**ISP817, ISP827, ISP847**

**ORDER INFORMATION**

<b>ISP817 (UL Approval)</b>			
<b>After PN</b>	<b>PN</b>	<b>Description</b>	<b>Packing quantity</b>
None	ISP817, ISP817GB, ISP817BL ISP817GR, ISP817A, ISP817B ISP817C, ISP817D	Standard DIP4	100 pcs per tube
G	ISP817G, ISP817GBG, ISP817BLG ISP817GRG, ISP817AG, ISP817BG ISP817CG, ISP817DG	10mm Lead Spacing	100 pcs per tube
SM	ISP817SM, ISP817GBSM, ISP817BLSM ISP817GRSM, ISP817ASM, ISP817BSM ISP817CSM, ISP817DSM	Surface Mount	100 pcs per tube
SMT&R	ISP817SMT&R, ISP817GBSMT&R ISP817GRSMT&R, ISP817BLSMT&R ISP817ASMT&R, ISP817BSMT&R ISP817CSMT&R, ISP817DSMT&R	Surface Mount Tape & Reel	1000 pcs per reel

<b>ISP827 (UL Approval)</b>			
<b>After PN</b>	<b>PN</b>	<b>Description</b>	<b>Packing quantity</b>
None	ISP827, ISP827GB, ISP827BL, ISP827GR, ISP827A, ISP827B, ISP827C, ISP827D	Standard DIP8	50 pcs per tube
G	ISP827G, ISP827GBG, ISP827BLG, ISP827GRG, ISP827AG, ISP827BG, ISP827CG, ISP827DG	10mm Lead Spacing	50 pcs per tube
SM	ISP827SM, ISP827GBSM, ISP827BLSM, ISP827GRSM, ISP827ASM, ISP827BSM, ISP827CSM, ISP827DSM	Surface Mount	50 pcs per tube
SMT&R	ISP827SMT&R, ISP827GBSMT&R, ISP827GRSMT&R, ISP827BLSMT&R, ISP827ASMT&R, ISP827BSMT&R, ISP827CSMT&R, ISP827DSMT&R	Surface Mount Tape & Reel	1000 pcs per reel

<b>ISP847 (UL Approval)</b>			
<b>After PN</b>	<b>PN</b>	<b>Description</b>	<b>Packing quantity</b>
None	ISP847, ISP847GB, ISP847BL, ISP847GR, ISP847A, ISP847B, ISP847C, ISP847D	Standard DIP16	25 pcs per tube
G	ISP847G, ISP847GBG, ISP847BLG, ISP847GRG, ISP847AG, ISP847BG, ISP847CG, ISP847DG	10mm Lead Spacing	25 pcs per tube
SM	ISP847SM, ISP847GBSM, ISP847BLSM, ISP847GRSM, ISP847ASM, ISP847BSM, ISP847CSM, ISP847DSM	Surface Mount	25 pcs per tube

## ISP817, ISP827, ISP847

### ORDER INFORMATION

**Note: grade-xX-VDE = VDE-Xx-grade (e.g. AX = XA, BX = XB,etc )**

ISP817X (UL and VDE Approvals)			
After PN	PN	Description	Packing quantity
None	ISP817X, ISP817XGB, ISP817XBL, ISP817XGR, ISP817XA, ISP817XB, ISP817XC, ISP817XD	Standard DIP4	100 pcs per tube
G	ISP817XG, ISP817XGBG, ISP817XBLLG, ISP817XGRG, ISP817XAG, ISP817XBG, ISP817XCG, ISP817XDG	10mm Lead Spacing	100 pcs per tube
SM	ISP817XSM, ISP817XGBSM, ISP817XGRSM, ISP817XBLSM, ISP817XASM, ISP817XBBSM, ISP817XCBSM, ISP817XDMSM	Surface Mount	100 pcs per tube
SMT&R	ISP817XSMT&R, ISP817XGBSMT&R, ISP817XGRSMT&R, ISP817XBLSMT&R, ISP817XASMT&R, ISP817XBSMT&R, ISP817XCBSMT&R, ISP817XDSMT&R	Surface Mount Tape & Reel	1000 pcs per reel

ISP827X (UL and VDE Approvals)			
After PN	PN	Description	Packing quantity
None	ISP827X, ISP827XGB, ISP827XBL, ISP827XGR, ISP827XA, ISP827XB, ISP827XC, ISP827XD	Standard DIP8	50 pcs per tube
G	ISP827XG, ISP827XGBG, ISP827XBLLG, ISP827XGRG, ISP827XAG, ISP827XBG, ISP827XCG, ISP827XDG	10mm Lead Spacing	50 pcs per tube
SM	ISP827XSM, ISP827XGBSM, ISP827XGRSM, ISP827XBLSM, ISP827XASM, ISP827XBBSM, ISP827XCBSM, ISP827XDMSM	Surface Mount	50 pcs per tube
SMT&R	ISP827XSMT&R, ISP827XGBSMT&R, ISP827XGRSMT&R, ISP827XBLSMT&R, ISP827XASMT&R, ISP827XBSMT&R, ISP827XCBSMT&R, ISP827XDSMT&R	Surface Mount Tape & Reel	1000 pcs per reel

ISP847 (UL and VDE Approvals)			
After PN	PN	Description	Packing quantity
None	ISP847X, ISP847XGBL, ISP847XBL, ISP847XGR, ISP847XA, ISP847XB, ISP847XC, ISP847XD	Standard DIP16	25 pcs per tube
G	ISP847XG, ISP847XGBG, ISP847XBLLG, ISP847XGRG, ISP847XAG, ISP847XBG, ISP847XCG, ISP847XDG	10mm Lead Spacing	25 pcs per tube
SM	ISP847XSM, ISP847XGBSM, ISP847XGRSM, ISP847XBLSM, ISP847XASM, ISP847XBBSM, ISP847XCBSM, ISP847XDMSM	Surface Mount	25 pcs per tube





## ISP817, ISP827, ISP847

### DEVICE MARKING

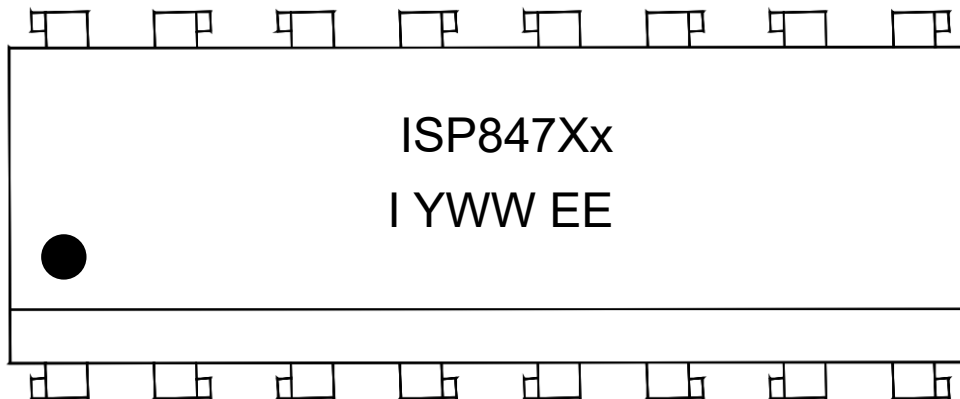
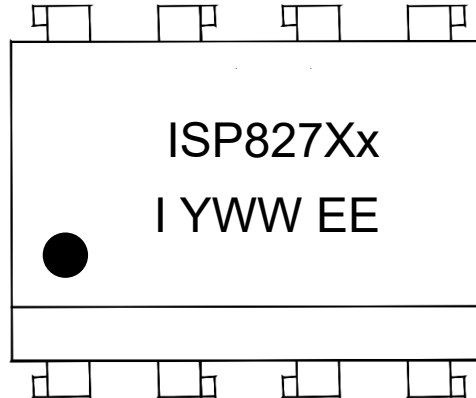
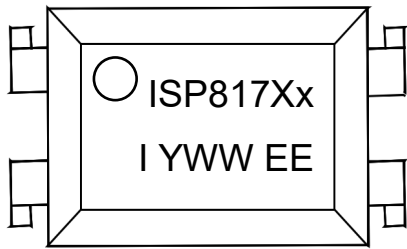

ISP817      Part Number for Single Channel

ISP827      Part Number for Dual Channel

ISP847      Part Number for Quad Channel

X            VDE Option

x            CTR Grade, e.g. A, B, C, etc.

Note : Alternate Marking xX (e.g. AX, BX, etc.)

I            Isocom

Y            Year code (can be single or double digit)

WW        2 digit Week code

EE        UL Model



## ISP817, ISP827, ISP847

### PACKAGE DIMENSIONS in mm (inch)

#### DIP

#### ISP817

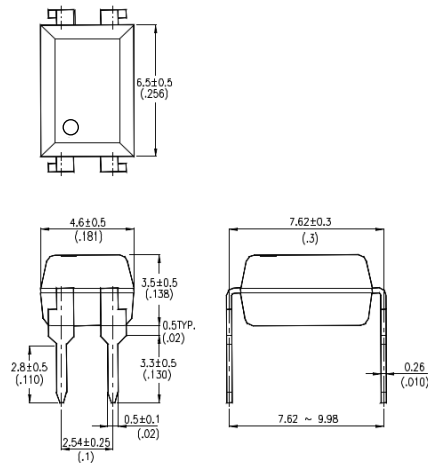

#### ISP827

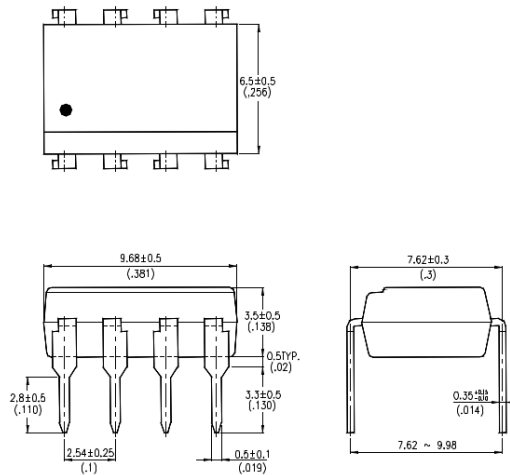

#### ISP847

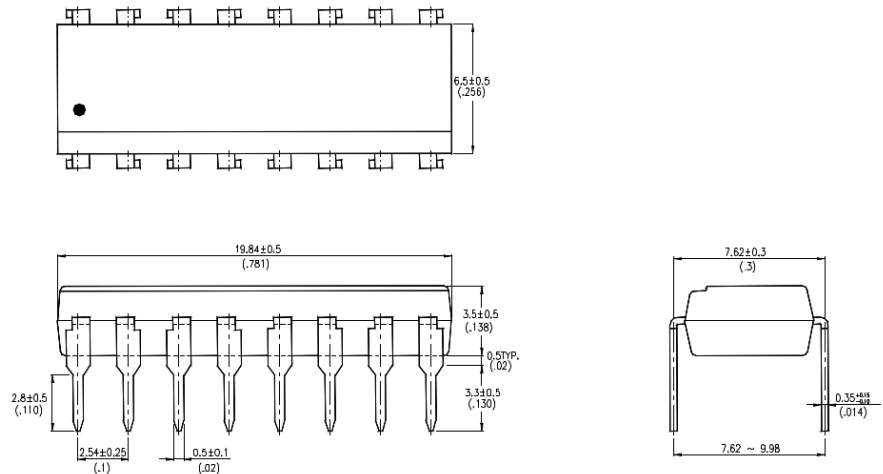

# ISP817, ISP827, ISP847

## PACKAGE DIMENSIONS in mm (inch)

### G Form

**ISP817G**

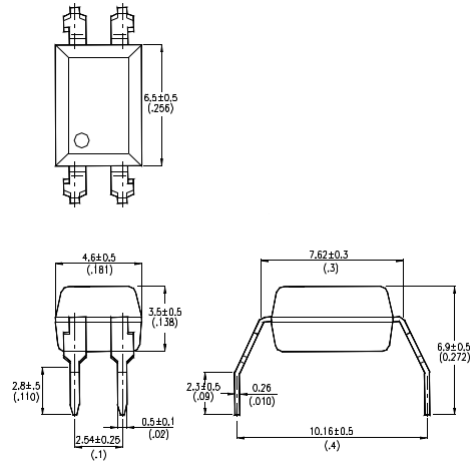

**ISP827G**

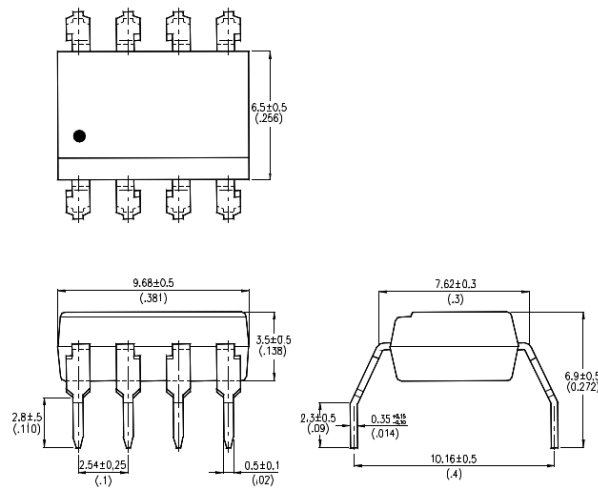

**ISP847G**

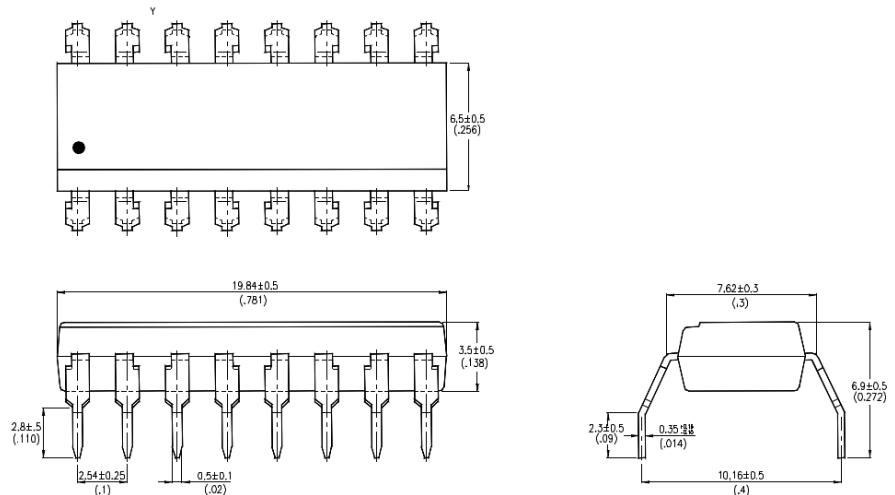



**ISP817, ISP827, ISP847**

**PACKAGE DIMENSIONS in mm (inch)**

**SMD**

**ISP817SM**

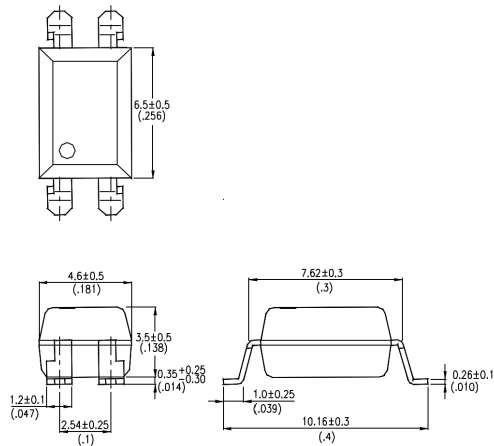

**ISP827SM**

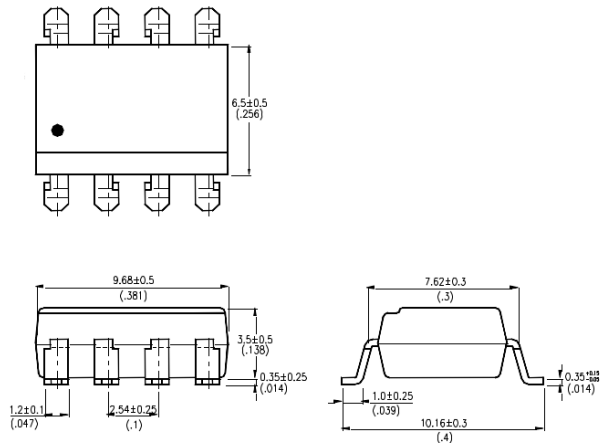

**ISP847SM**

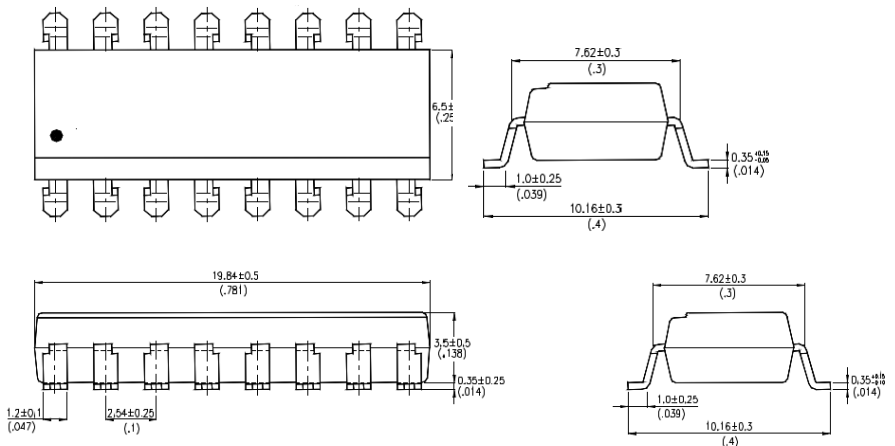



**ISP817, ISP827, ISP847**

**RECOMMENDED PAD LAYOUT FOR SMD (mm)**

**ISP817SM**

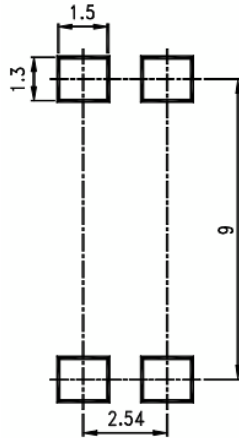

**ISP827SM**

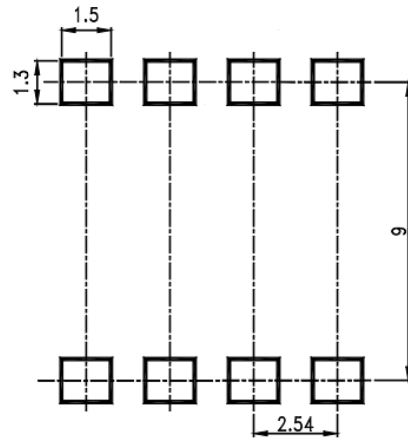

**ISP847SM**

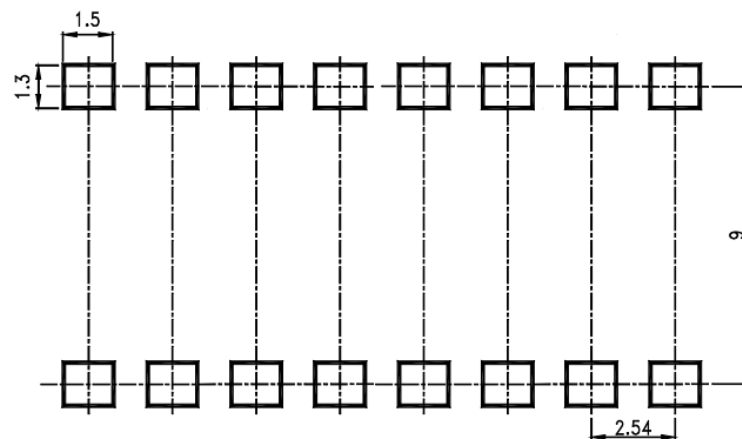



**ISP817, ISP827, ISP847**

**TAPE AND REEL PACKAGING**

**ISP817SMT&R**

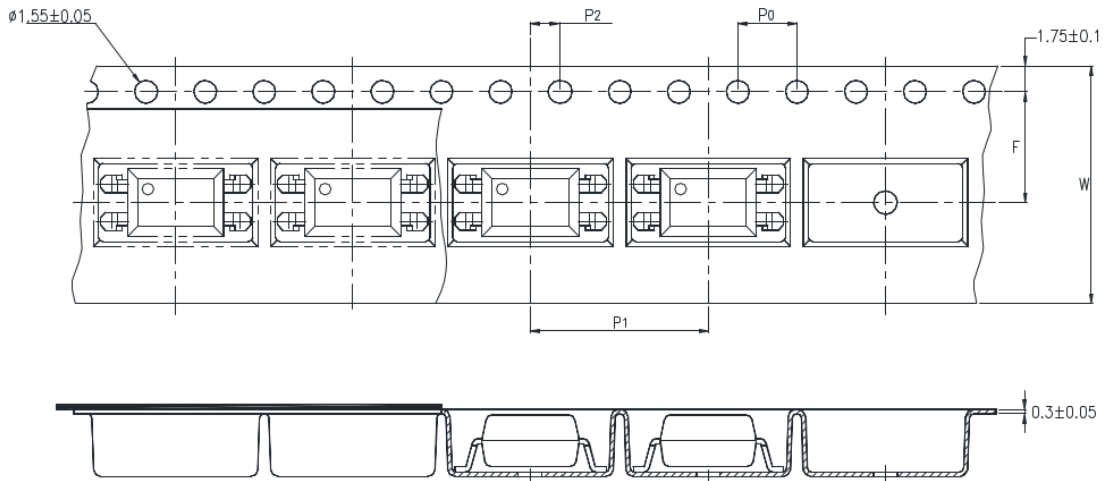

**ISP827SMT&R**

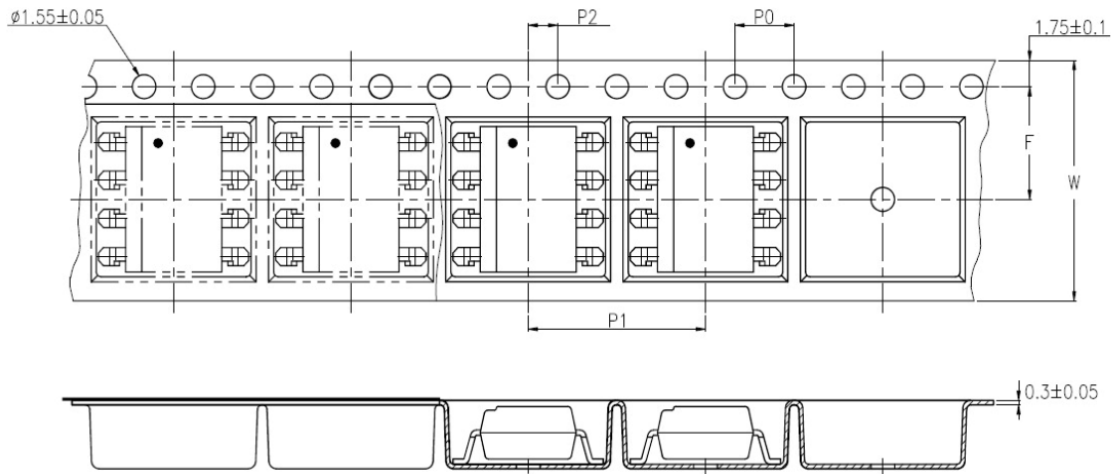

Description	Symbol	Dimension mm (inch)
Tape Width	W	$16 \pm 0.3$ (0.63)
Pitch of Sprocket Holes	$P_0$	$4 \pm 0.1$ (0.15)
Distance of Compartment to Sprocket Holes	F	$7.5 \pm 0.1$ (0.295)
	$P_2$	$2 \pm 0.1$ (0.079)
Distance of Compartment to Compartment	$P_1$	$12 \pm 0.1$ (0.472)



**ISP817, ISP827, ISP847**

**IR REFLOW SOLDERING TEMPERATURE PROFILE FOR SMD**  
**One Time Reflow Soldering is Recommended.**  
**Do Not Immerse Device Body in Solder Paste.**

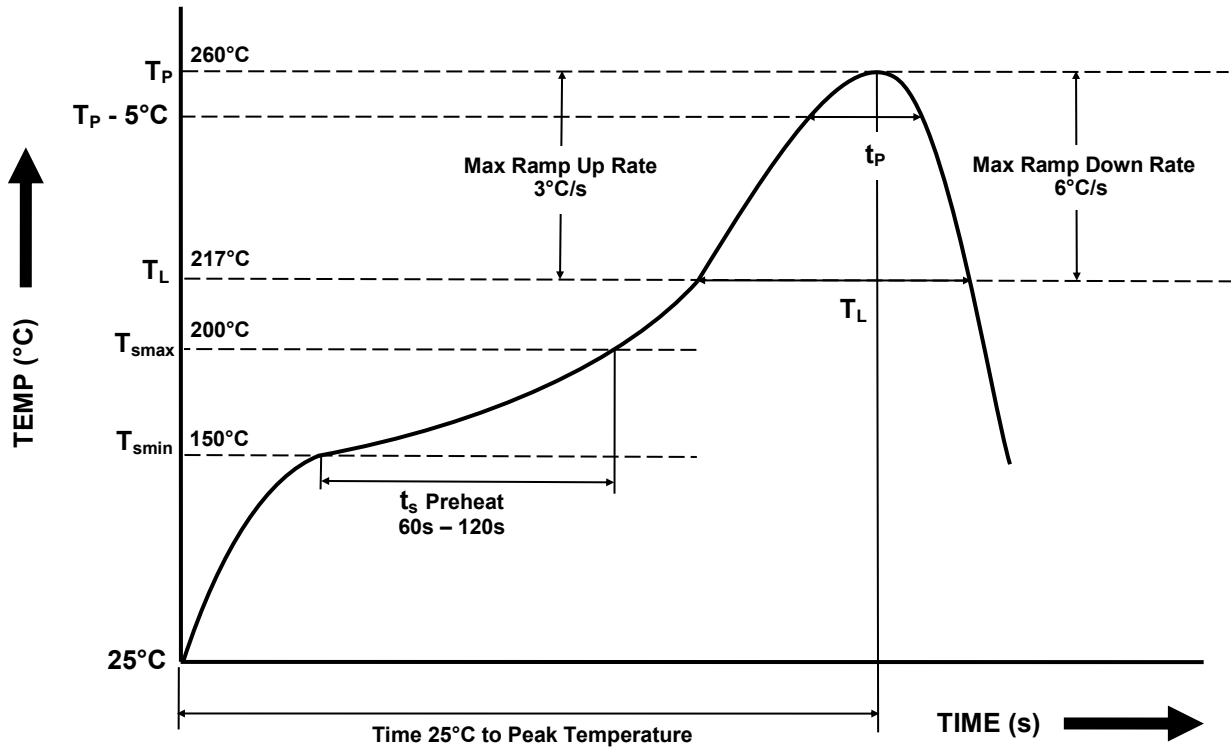

Profile Details	Conditions
<b>Preheat</b> - Min Temperature ( $T_{SMIN}$ ) - Max Temperature ( $T_{SMAX}$ ) - Time $T_{SMIN}$ to $T_{SMAX}$ ( $t_s$ )	150°C 200°C 60s - 120s
<b>Soldering Zone</b> - Peak Temperature ( $T_P$ ) - Time at Peak Temperature - Liquidous Temperature ( $T_L$ ) - Time within 5°C of Actual Peak Temperature ( $T_P - 5^\circ C$ ) - Time maintained above $T_L$ ( $t_L$ ) - Ramp Up Rate ( $T_L$ to $T_P$ ) - Ramp Down Rate ( $T_P$ to $T_L$ )	260°C 10s max 217°C 30s max 60s - 100s 3°C/s max 6°C/s max
Average Ramp Up Rate ( $T_{smax}$ to $T_P$ )	3°C/s max
Time 25°C to Peak Temperature	8 minutes max



## DISCLAIMER

Isocom Components is continually working to improve the quality and reliability of its products. Nevertheless, semiconductor devices in general can malfunction or fail due to their inherent electrical sensitivity and vulnerability to physical stress. It is the responsibility of the buyer, when utilizing Isocom Components products, to comply with the standards of safety in making a safe design for the entire system, and to avoid situations in which a malfunction or failure of such Isocom Components products could cause loss of human life, bodily injury or damage to property.

In developing your designs, please ensure that Isocom Components products are used within specified operating ranges as set forth in the most recent Isocom Components products specifications.

The Isocom Components products listed in this document are intended for usage in general electronics applications (computer, personal equipment, office equipment, measuring equipment, industrial robotics, domestic appliances, etc.). These Isocom Components products are neither intended nor warranted for usage in equipment that requires extraordinarily high quality and/or reliability or a malfunction or failure of which may cause loss of human life or bodily injury ("Unintended Usage"). Unintended Usage include atomic energy control instruments, airplane or spaceship instruments, transportation Instruments, traffic signal instruments, combustion control instruments, medical Instruments, all types of safety devices, etc... Unintended Usage of Isocom Components products listed in this document shall be made at the customer's own risk.

Gallium arsenide (GaAs) is a substance used in the products described in this document. GaAs dust and fumes are toxic. Do not break, cut or pulverize the product, or use chemicals to dissolve them. When disposing of the products, follow the appropriate regulations. Do not dispose of the products with other industrial waste or with domestic garbage.

The products described in this document are subject to the foreign exchange and foreign trade laws.

The information contained herein is presented only as a guide for the applications of our products. No responsibility is assumed by Isocom Components for any infringements of intellectual property or other rights of the third parties which may result from its use. No license is granted by implication or otherwise under any intellectual property or other rights of Isocom Components or others.

The information contained herein is subject to change without notice.



单击下面可查看定价，库存，交付和生命周期等信息

[>>ISOCOM](#)