

# 承 认 书

## SPECIFICATION FOR APPROVAL

客户名称: Customer \_\_\_\_\_

货 名: Description SMD 3225 GLASS 石英晶体谐振器

客户料号: Part No \_\_\_\_\_

物料编号: Code No G3226000071060

频 率: Frequency 26.000MHz

日 期: Date 2020-06-11

备 注: RoHS 豁免条款 7 (a)

制作(Prepare by)	检查(Check by)	批准 (Approve by)
江丹娜	甘瑛	张刚

客户批准 Approve by customer	
批准日期 Approval date	

Add:广东省深圳市华发北路桑达工业区桑达雅苑 7P

7 P Sangda Yayuan Huafa North Road, Futian District, Shenzhen, Guangdong

Tel: 86-755-83048260 86-755-83048290

Fax: 86-755-83048280

## 1、 Specifications

1	规格型号 <b>Holder Type</b>	SMD GLASS 3225
2	标称频率 <b>Nominal Frequency</b>	26.000MHz
3	振动模式 <b>Mode of Oscillation</b>	Fundamental
4	调整频差 <b>Frequency Tolerance at 25°C</b>	±10ppm
5	温度频差 <b>Temperature Frequency Stability</b>	±30ppm
6	工作温度 <b>Operating Temperature Range</b>	-40~85°C
7	贮存温度 <b>Storage Temperature Range</b>	-40~90°C
8	负载电容 <b>Load Capacitance</b>	7.5 pF
9	静电容 <b>Shunt capacitance</b>	≤7 pF
10	等效电阻 <b>Equivalent Series Resistance</b>	60Ω Max
11	激励功率 <b>Drive Level</b>	10 uW
12	绝缘阻抗 <b>Insulation Resistance</b>	500MΩ/100V±15V <sub>DC</sub>
13	老化率 <b>Aging</b>	±3ppm/First year
14	测试仪器 <b>Test machine</b>	250B

## 2. Frequency stability over temperature range (AT cut)

Temperature Range	Frequency Stability							
	±3PPM	±5PPM	±7.5PPM	±10PPM	±20PPM	±30PPM	±50PPM	±70PPM
0°C~+50°C	☆	☆	☆	☆	☆	☆	☆	☆
-10°C~+60°C			☆	☆	☆	☆	☆	☆
-20°C~+70°C				☆	☆	☆	☆	☆
-30°C~+70°C					☆	☆	☆	☆
-40°C~+85°C						☆	☆	☆
-40°C~+125°C						☆	☆	☆

### 3. Dimensions (unit:mm)

**■ DIMENSIONS**  
(Unit:mm)

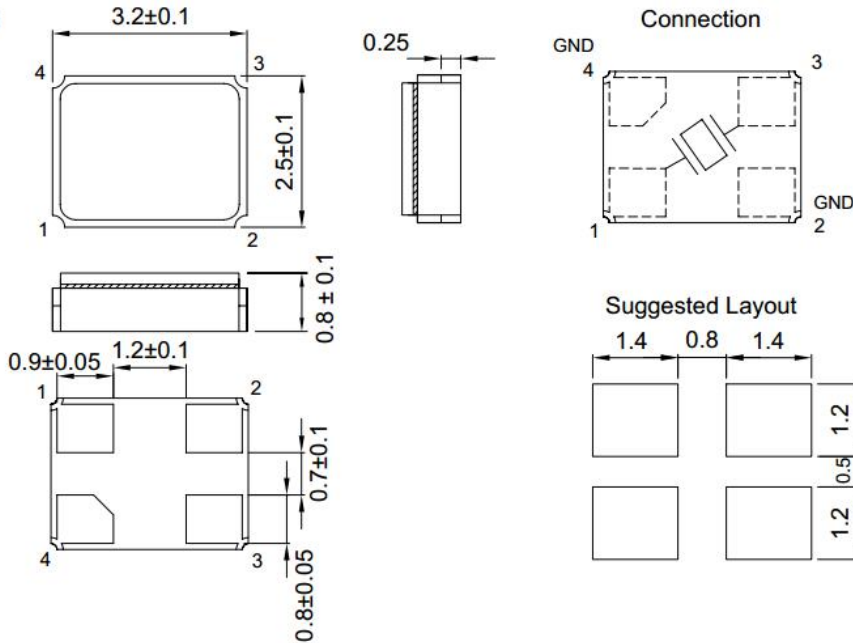

\*Coplanarity of solderable areas Camber 0.10 mm Max

### 4. Recommended Reflow profile

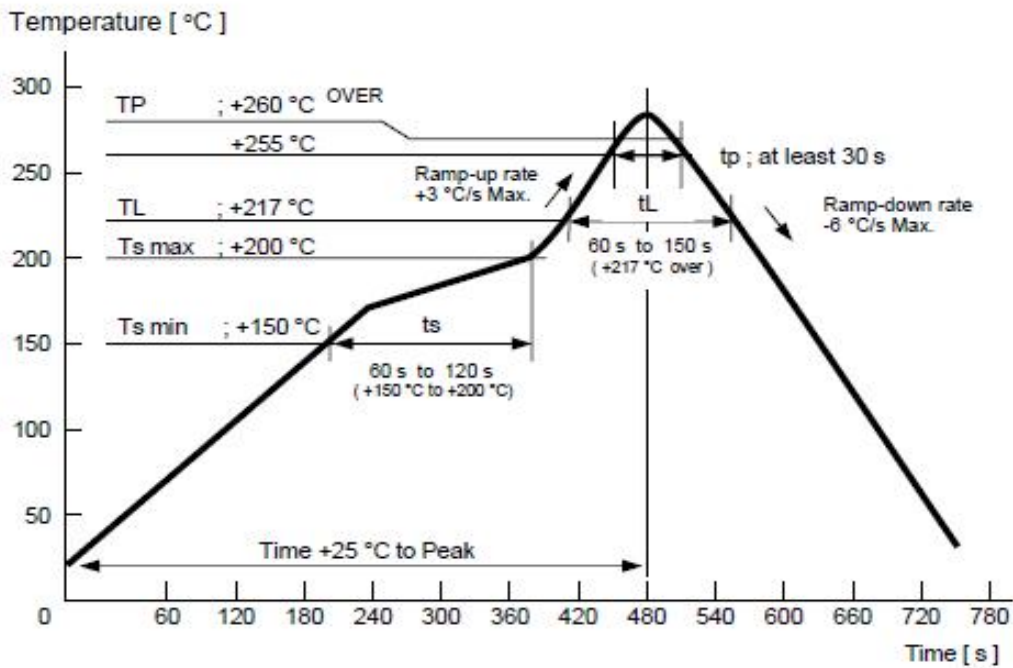

## 5、Reliability specifications

	Item	Condition	Standard
1.	Drop characteristics	Free drop from 75cm height on a hard wooden board for 3 times. (Board is thickness more than 30 mm.)	Frequency change: ≤5ppm Rr as specification
2..	Shake characteristics	Shake frequency 10~55Hz, cyc1~2 minutes, swing 1.5mm, direction x/y/z, all 30 minutes, test after 1 hours.	Frequency change: ≤5ppm Rr as specification
3.	Airproof characteristics	Put crystal into the pressure cabin with alcohol, keep pressure 0.4~0.5mpa 10 minutes, then take out and blow for 5 minutes	IR≥500MΩ
4.	Weld characteristics	260±5℃, 3 seconds	90% exhibit tin ok
5.	Humidity characteristics	+40±2℃ & 90%~95% R.H. 250 hours	Frequency change: ≤5ppm Rr as specification
6.	Low temperature characteristics	-30±2℃, 250 hours, put in room temperature, test after 1 hours.	Frequency change: ≤5ppm Rr as specification
7.	High temperature characteristics	+85±2℃, 250 hours, put in room temperature, test after 1 hours.	Frequency change: ≤5ppm Rr as specification
8.	Temperature cycling	-30±3℃/30±3 min~+85±2℃/30±3min, 5 cycles	Frequency change: ≤5ppm Rr as specification

## 6、Packaging standard

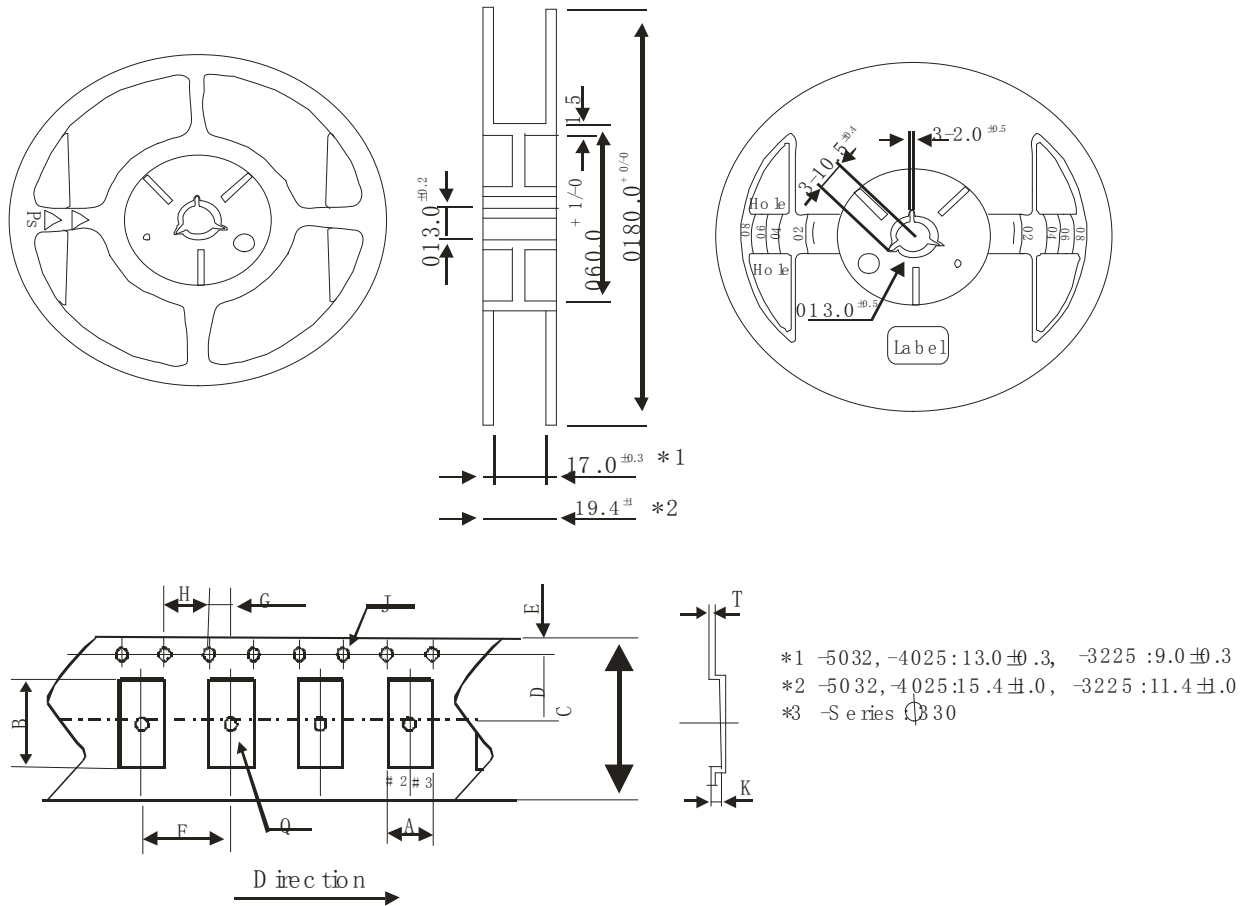

- Standard quantity of ST -3225 : 3,000 pcs/reel
- Standard quantity of SN -Series : 4,000 pcs/reel
- Standard quantity of others : 1,000 pcs/reel
- Carrier tape : Antistatic material (PS)
- Each reel can be recycled

	SJ-7050 SN-7050	SJ-6032 SN-6032	SJ-5032	SJ -5032	SJ-4025	SJ-3225
A	5.4 <sup>±0.1</sup>	3.9 <sup>±0.1</sup>	3.5 <sup>±0.1</sup>	3.5 <sup>±0.1</sup>	2.9 <sup>±0.1</sup>	2.9 <sup>±0.1</sup>
B	7.4 <sup>±0.1</sup>	6.4 <sup>±0.1</sup>	5.4 <sup>±0.1</sup>	5.4 <sup>±0.1</sup>	4.4 <sup>±0.1</sup>	3.6 <sup>±0.1</sup>
C	16.0 <sup>±0.2</sup>	16.0 <sup>±0.2</sup>	12.0 <sup>±0.2</sup>	12.0 <sup>±0.2</sup>	10.0 <sup>±0.2</sup>	8.0 <sup>±0.2</sup>
D	7.5 <sup>±0.1</sup>	7.5 <sup>±0.1</sup>	5.5 <sup>±0.1</sup>	5.5 <sup>±0.1</sup>	5.5 <sup>±0.1</sup>	5.5 <sup>±0.1</sup>
E	1.75 <sup>±0.1</sup>	1.75 <sup>±0.1</sup>	1.75 <sup>±0.1</sup>	1.75 <sup>±0.1</sup>	1.75 <sup>±0.1</sup>	1.75 <sup>±0.1</sup>
F	8.0 <sup>±0.1</sup>	8.0 <sup>±0.1</sup>	8.0 <sup>±0.1</sup>	8.0 <sup>±0.1</sup>	4.0 <sup>±0.1</sup>	4.0 <sup>±0.1</sup>
G	2.0 <sup>±0.1</sup>	2.0 <sup>±0.1</sup>	2.0 <sup>±0.1</sup>	2.0 <sup>±0.1</sup>	2.0 <sup>±0.1</sup>	2.0 <sup>±0.1</sup>
H	4.0 <sup>±0.1</sup>	4.0 <sup>±0.1</sup>	4.0 <sup>±0.1</sup>	4.0 <sup>±0.1</sup>	4.0 <sup>±0.1</sup>	4.0 <sup>±0.1</sup>
J	1.55 <sup>±0.05</sup>	1.55 <sup>±0.05</sup>	1.5 <sup>+0.1/0</sup>	1.5 <sup>+0.1/0</sup>	1.5 <sup>+0.1/0</sup>	1.5 <sup>+0.1/0</sup>
K	1.4 <sup>±0.1</sup>	1.5 <sup>±0.1</sup>	1.0 <sup>±0.1</sup>	1.5 <sup>±0.1</sup>	0.9 <sup>±0.1</sup>	0.9 <sup>±0.1</sup>
Q	1.6 <sup>+0.1/0</sup>	1.55 <sup>±0.05</sup>	1.6 <sup>±0.1</sup>	1.6 <sup>±0.1</sup>	1.5 <sup>±0.1/0</sup>	1.5 <sup>±0.1/0</sup>
T	0.3 <sup>±0.05</sup>	0.3 <sup>±0.05</sup>	0.25 <sup>±0.05</sup>	0.25 <sup>±0.05</sup>	0.25 <sup>±0.05s</sup>	0.25 <sup>±0.05s</sup>

Item		Empty Space
Tapa Leader	Cover Tape	Min.500mm
	Empty Pockets	Min.20 pockets
Tape Trailer	Cover Tape	Min.0mm
	Empty Pockets	Min.40mm

**7. Inner carton**

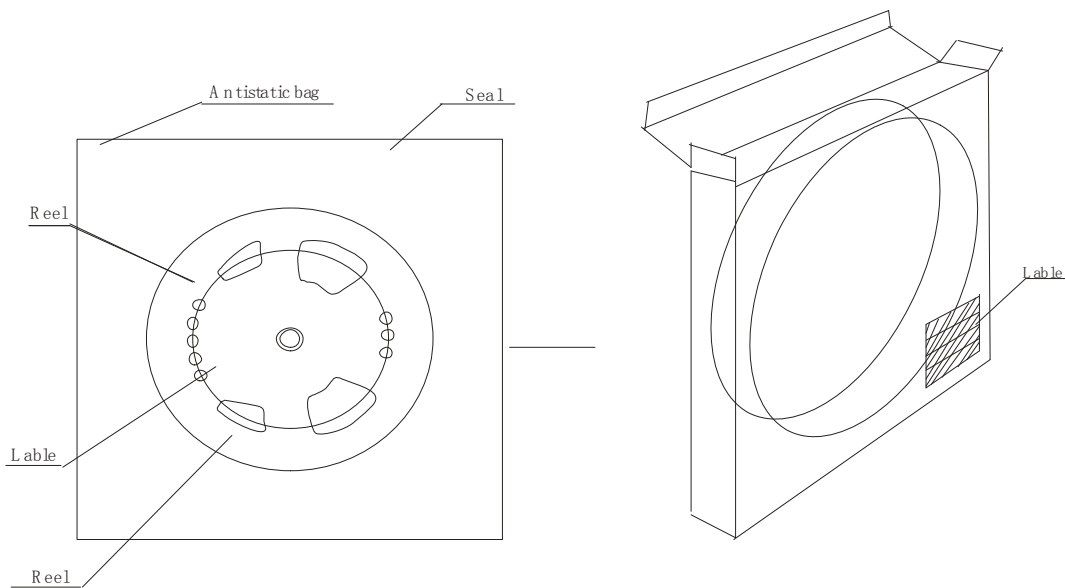

**OUTET CARTON**

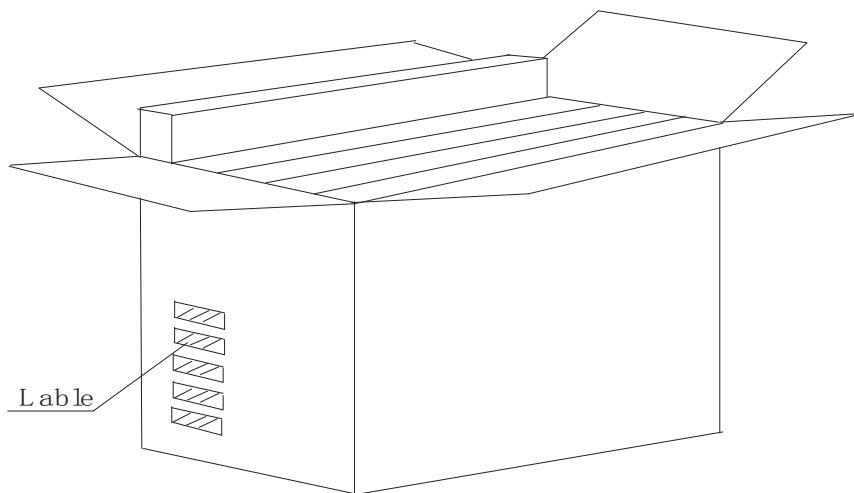

## 7-1. MARKING

- (1) Marking Labels are affixed to reel, inner carton and outer carton.
- (2) Each label contains the following information.
  - (a) Manufacture's name or symbol
  - (b) Parts name or type
  - (c) Frequency
  - (d) Quantity
  - (e) Reel number
  - (f) Manufacturer's code (EIAJ code)

## 7-2. QUANTITY

3000pcs/reel (max.5reels in outer carton)

## 7-3. STORAGE ENVIRONMENT

- ✧ Storage the reel at normal temperature and humidity
- ✧ Open the packing just before using
- ✧ Do not expose the sun
- ✧ Do not storage with some erosive chemicals
- ✧ Nothing is allowed to put on the reel or carton to prevent mechanical damage

## 7-4. HANDLING

- ✧ Handle with care to prevent the damage of tape, reel and products.

单击下面可查看定价，库存，交付和生命周期等信息

[>>JGHC\(晶光华\)](#)