

承 认 书

SPECIFICATION FOR APPROVAL

客户名称: Customer _____

货 名: Description SMD 5.0*3.2 Glass Sealing XTAL(2pad)

客户料号: Part No _____

物料编号: Code No G53080000850100A

频 率: Frequency 8.000MHz

日 期: Date 2020-06-11

备 注: RoHS 豁免条款 7 (a)

制作(Prepare by)	检查(Check by)	批准 (Approve by)
江丹娜	甘瑛	张刚

客户批准 Approve by customer	
批准日期 Approval date	

Add:广东省深圳市华发北路桑达工业区桑达雅苑 7P

7 P Sangda Yayuan Huafa North Road, Futian District, Shenzhen, Guangdong

Tel: 86-755-83048260

86-755-83048290

Fax: 86-755-83048280

1、 Specifications

1	规格型号 Holder Type	5.0*3.2 SMD Glass
2	标称频率 Nominal Frequency	8.000MHz
3	振动模式 Mode of Oscillation	Fundamental
4	调整频差 Frequency Tolerance at 25℃	±50ppm
5	温度频差 Temperature Frequency Stability	±30ppm
6	工作温度 Operating Temperature Range	-40~85℃
7	贮存温度 Storage Temperature Range	-40~90℃
8	负载电容 Load Capacitance	8 pF
9	静电容 Shunt capacitance	≤7 pf
10	等效电阻 Equivalent Series Resistance	100 Ω Max
11	激励功率 Drive Level	10uW(typical)
12	绝缘阻抗 Insulation Resistance	500MΩ/100V±15V _{DC}
13	年老化率 Aging	±2ppm/First year
14	测试仪器 Test machine	250B

2. Frequency stability over temperature range (AT cut)

Temperature Range	Frequency Stability							
	±3PPM	±5PPM	±7.5PPM	±10PPM	±20PPM	±30PPM	±50PPM	±70PPM
0℃~+50℃	☆	☆	☆	☆	☆	☆	☆	☆
-10℃~+60℃			☆	☆	☆	☆	☆	☆
-20℃~+70℃				☆	☆	☆	☆	☆
-30℃~+70℃					☆	☆	☆	☆
-40℃~+85℃						☆	☆	☆
-40℃~+125℃						☆	☆	☆

3. Dimensions (unit:mm)

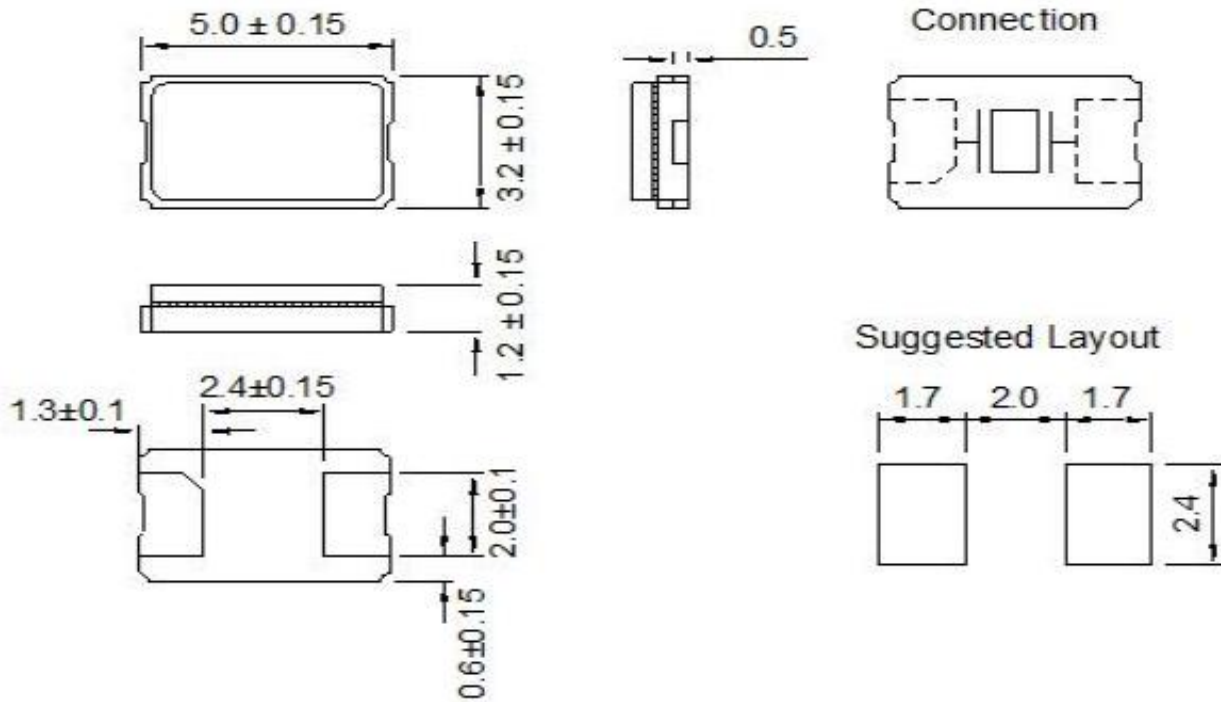

4. Recommended Reflow profile

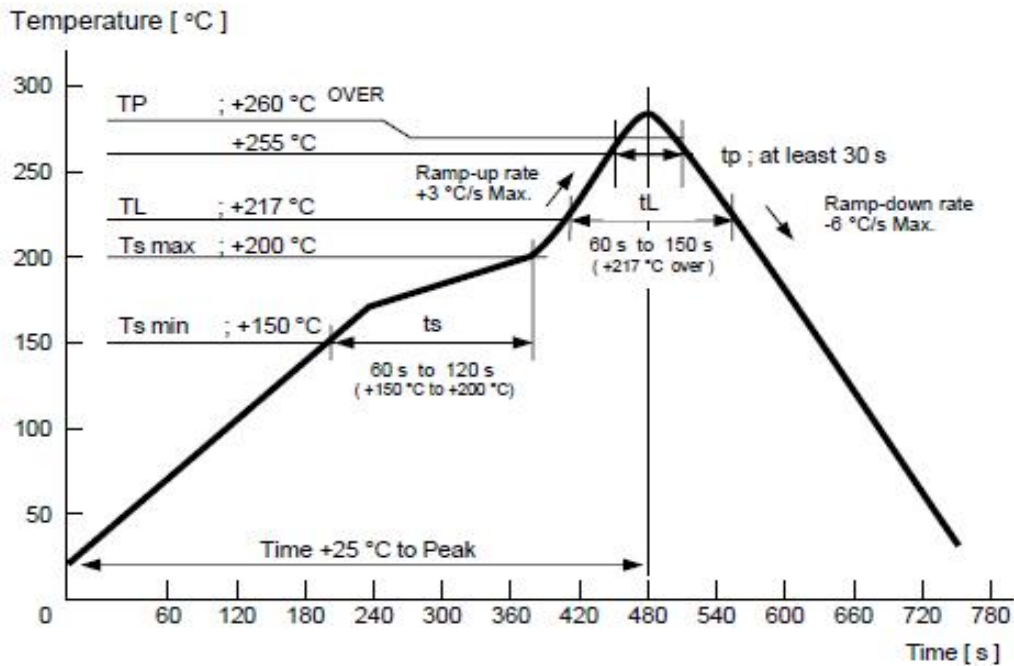

5、Reliability specifications(conform to AEC-Q200)

NO.	Item	Test Condition	Reference Doc.
1.	Drop	1m height ,hard wooden board(board thickness:30mm min.), 3times	IEC-68-2-32
2.	Low temperature storage	-40±3℃,1000 hours, unpowered.	MIL-STD-883E
3.	High temperature storage	+125±3℃,1000 hours, unpowered.	MIL-STD-202 Method 108
	(Operation life)	+125±3℃,1000 hours, power	
4.	Temperature cycling	Total 1000 cycles of the following temperature cycle: -40±3 to 125±3℃, Dwell time:15min	JESD 22 Method JA-104
5.	Moisture Resistance	20cycles(25~65℃, 80~100%RH),24hrs/cycles	MIL-STD-202 Method 106
6.	Biased Humidity	+85±3℃ & 85% RH, 1000 hours	MIL-STD-202 Method 103
7.	Mechanical Shock	Condition C: Peak value:100g's normal duration:6ms Waveform:half sine velocity change:12.3ft/sec	MIL-STD-202 Method 213
8.	Vibration	5g's for 20 minutes 12 cycles each of 3 orientations Test form 10~2000Hz	MIL-STD-202 Method 204
9.	Resistance to soldering heat	Pre-heat temperature:125℃ Pre-heat time:60~120s. Test temperature:260± 5℃ Test time:10± 1sec.	MIL-STD-202 Method 210
10.	Thermal shock	-55±3℃~+125±3℃,Cycles:300, Dwell time:5minutes, Max. transfer time:20mintutes air-air	MIL-STD-202 Method 107
11.	Solderability	Temperature :245 ℃ ± 5℃ Immersing depth:0.5 mm min.Immersion time:5 ± 1 sec. Flux Rosin resin methyl alcohol solvent (1 : 4)	J-STD-002
12.	Terminal strength	Mount on PCB board and shear strength 1.8kg for 60sec.	AEC-Q200-006

6. Emboss carrier tape & reel

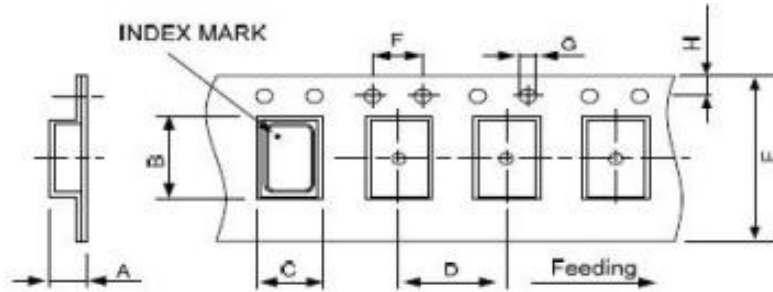

DIMENSIONS	A	B	C	D	E	F	G	H	(UNIT : mm)
	1.65±0.10	5.40±0.10	3.50±0.10	8.00±0.10	12.00±0.30	4.00±0.10	1.55±0.10	1.75±0.10	

REMARK :

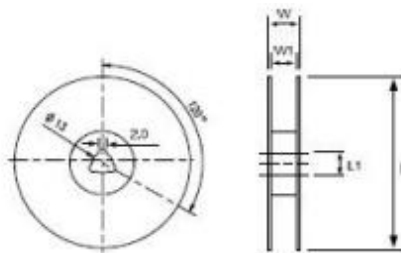
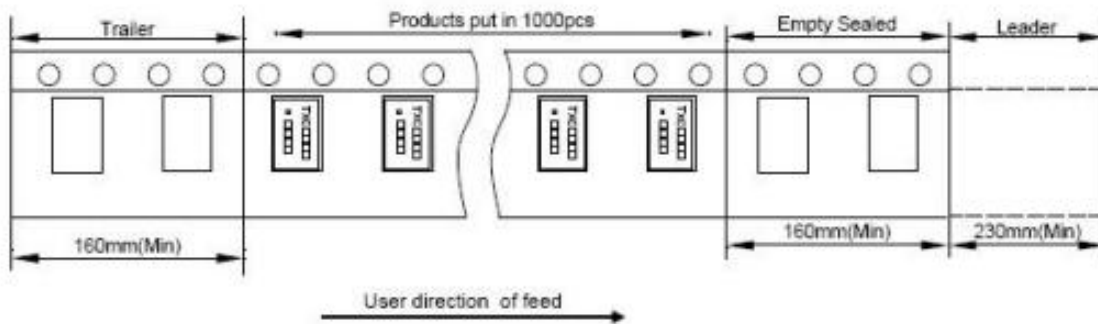

DIMENSIONS	L	L1	W	W1	(UNIT : mm)
	180±1.00	13±0.50	16.5±0.20	12±0.10	

7. Inner carton

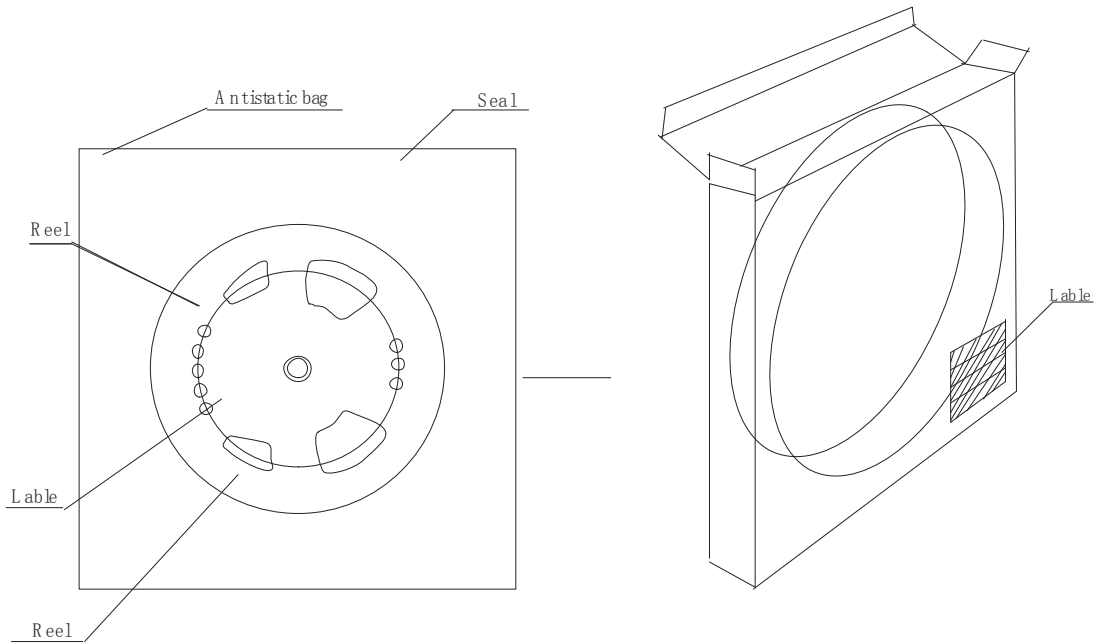

OUTET CARTON

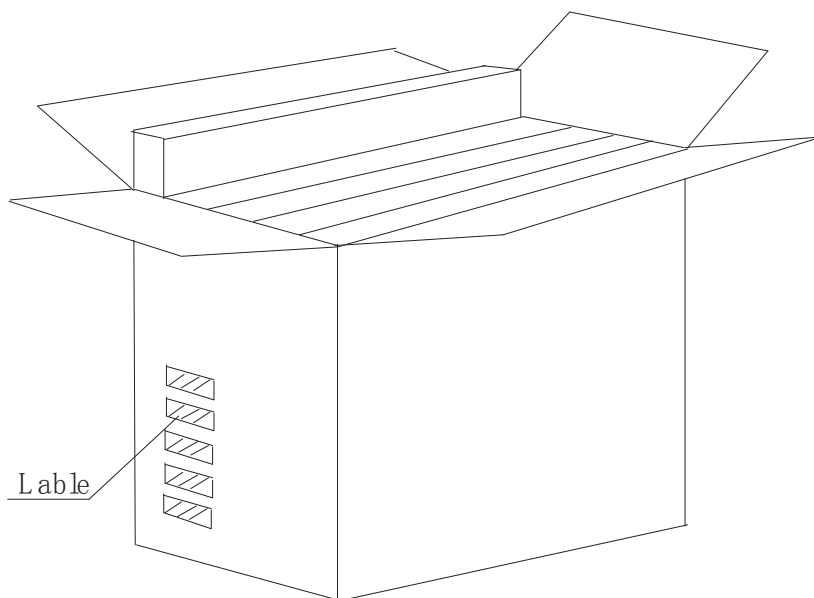

7-1. MARKING

- (1) Marking Labels are affixed to reel, inner carton and outer carton.
- (2) Each label contains the following information.
 - (a) Manufacture's name or symbol
 - (b) Parts name or type
 - (c) Frequency
 - (d) Quantity
 - (e) Reel number
 - (f) Manufacturer's code (EIAJ code)

7-2. QUANTITY

1000pcs/reel (max.5reels in outer carton)

7-3. STORAGE ENVIRONMENT

- ✧ Storage the reel at normal temperature and humidity
- ✧ Open the packing just before using
- ✧ Do not expose the sun
- ✧ Do not storage with some erosive chemicals
- ✧ Nothing is allowed to put on the reel or carton to prevent mechanical damage

7-4. HANDLING

- ✧ Handle with care to prevent the damage of tape, reel and products.

单击下面可查看定价，库存，交付和生命周期等信息

[>>JGHC\(晶光华\)](#)