



承 认 书

SPECIFICATION FOR APPROVAL

客户名称: Customer _____

货 名: Description SMD 3225 XO CMOS 石英晶体振荡器

客户料号: Part No _____

物料编号: Code No 032125000153325

频 率: Frequency 125.000MHz

日 期: Date 2020-05-25

备 注: RoHS compliance with Directive (EU) 2015/863

| 制作(Prepare by) | 检查(Check by) | 批准 (Approve by) |
|----------------|--------------|-----------------|
| 江丹娜 | 甘瑛 | 张刚 |

| | |
|-----------------------------|--|
| 客户批准 Approve by customer | |
| 批准日期 Approval date | |

Add:广东省深圳市华发北路桑达工业区桑达雅苑 7P

7 P Sangda Yayuan Huafa North Road, Futian District, Shenzhen, Guangdong

Tel: 86-755-83048260

86-755-83048290

Fax: 86-755-83048280

■ ELECTRICAL SPECIFICATIONS

Standard atmospheric conditions

Unless otherwise specified, the standard range of atmospheric conditions for making measurement and tests are as follow:

Ambient temperature : 25±5℃

Relative humidity : 40%~70%

If there is any doubt about the results, measurement shall be made within the following limits:

Ambient temperature : 25±3℃

Relative humidity : 40%~70%

Measure equipment

Electrical characteristics measured by MD 37WX-05M or equivalent.

Crystal cutting type

The crystal is using AT CUT (thickness shear mode).

■ Electrical characteristics

Frequency

| | Parameters | Symbol | Electrical Spec. | | | | Notes |
|----|---------------------------|--------|------------------|------|--------|---------|------------------|
| | | | Min. | Typ. | Max. | Units | |
| 1 | Nominal Frequency | - | 125.000 | | | MHz | - |
| 2 | Frequency Stability | - | ±25 | | | ppm | - |
| 3 | Operating Temperature | Topr | -40 | 25 | 85 | ℃ | - |
| 4 | Storage Temperature | Tstg | -55 | ~ | 125 | ℃ | - |
| 5 | Supply Voltage | VDD | 3.3 ±10% | | | V | - |
| 6 | Input Current | Icc | - | - | 3 | mA | - |
| 7 | Enable Control | - | Yes | | | - | Pad 1 |
| 8 | Output Load : CMOS | CL | 15 | | | pF | - |
| 9 | Output Voltage High | VoH | 90%Vdd | - | - | V | - |
| 10 | Output Voltage Low | VoL | - | - | 10%Vdd | V | - |
| 11 | Rise Time | Tr | - | - | 10 | ns | 10%→90%VDD Level |
| 12 | Fall Time | Tf | - | - | 10 | ns | 90%→10%VDD Level |
| 13 | Symmetry (Duty ratio) | TH/T | 45 | ~ | 55 | % | - |
| 14 | Start-up Time | Tosc | - | - | 10 | ms | - |
| 15 | Enable Voltage High | Vhi | 70%Vdd | - | - | V | - |
| 16 | Disable Voltage Low | Vlo | - | - | 30%Vdd | V | - |
| 17 | Aging | - | ±3 | | | ppm/yr. | 1st. Year at 25℃ |
| 18 | Output Disable Delay Time | T off | - | - | 150 | μS | - |
| 19 | Output Enable Delay Time | T on | - | - | 150 | μS | - |

■ TEST DIAGRAM

Control input (output enable/disable)

Logic 1 or open on pad 1: Oscillator output

Logic 0 on pad 1 : Disable output to high impedance



■ WAVEFORM CONDITIONS

Waveform measurement system

should have a min. bandwidth of 5

times the frequency being tested.



■ SUGGESTED REFLOW PROFILE

Total time : 200 sec. Max.

Solder melting point :220 °C

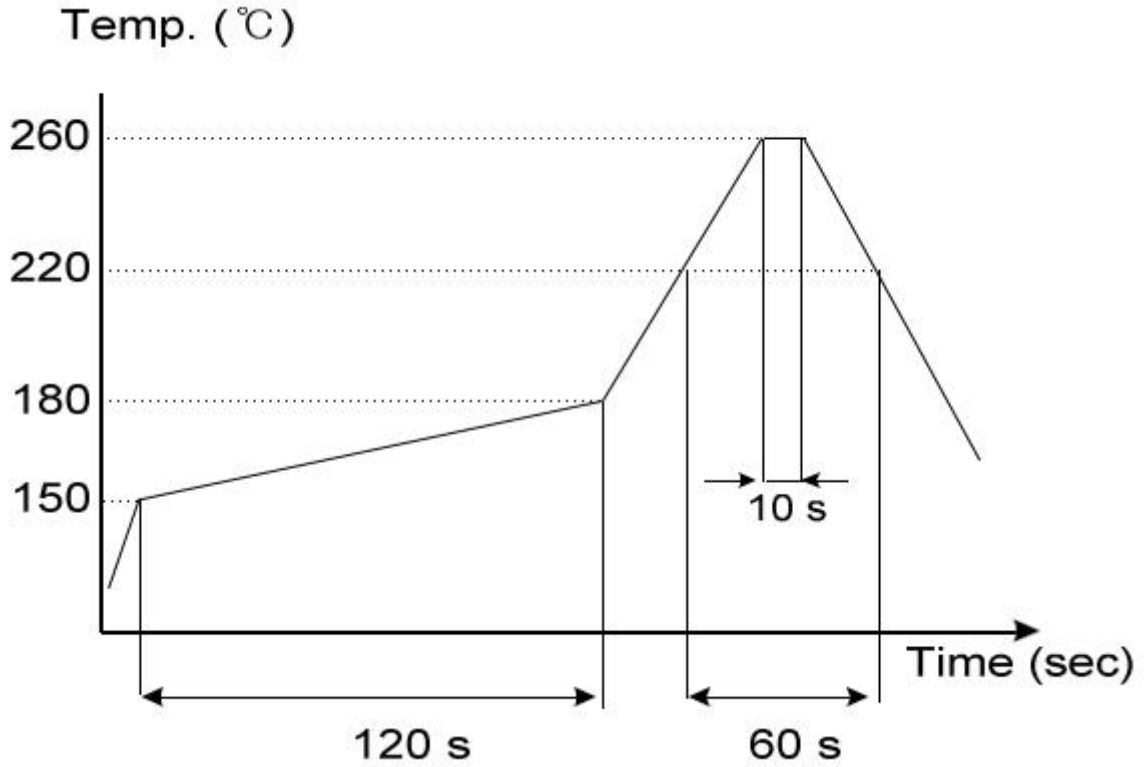

■ PRODUCT DIMENSIONS

(Unit:mm)

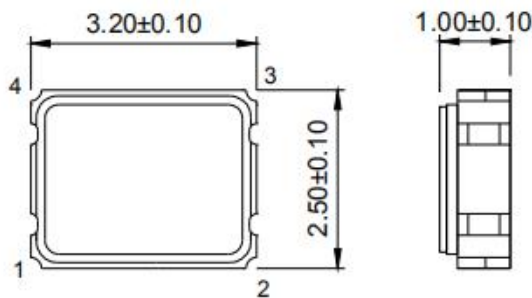

PAD FUNCTION:

- 1: ENABLE CONTROL
- 2: GND
- 3: OUT
- 4: VDD

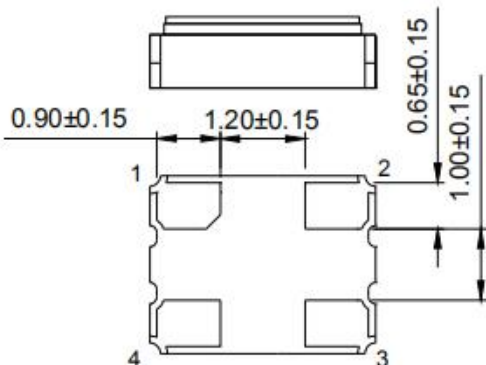

Suggested Layout

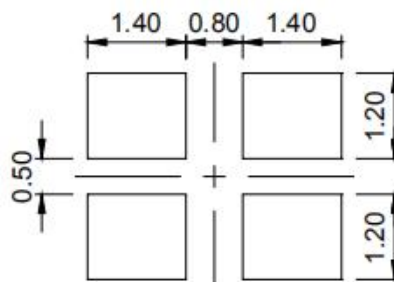

■ STRUCTURE ILLUSTRATION

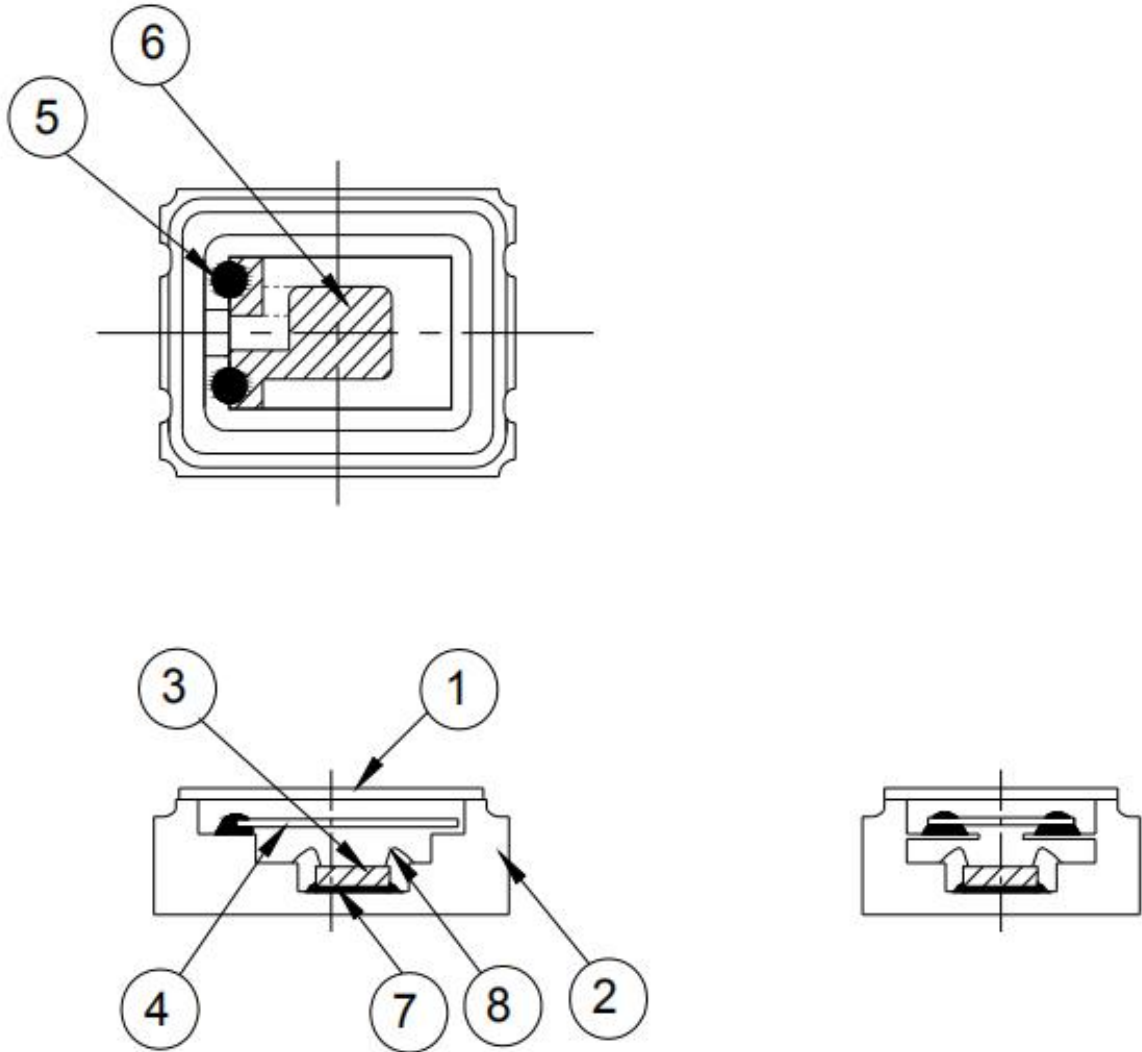

| NO | COMPONENTS | MATERIA LS | FINISH/SPECIFICATIONS |
|----|---------------------|---|---|
| 1 | Lid | Kovar (Fe/Co/Ni) | - |
| 2 | Base (Package) | Ceramic (Al ₂ O ₃) + Kovar (Fe/Co/Ni)+Pad (Au) | - |
| 3 | IC chip | - | - |
| 4 | Crystal blank | SiO ₂ | - |
| 5 | Conductive adhesive | Ag | Silicon resin |
| 6 | Electrode | Noble Metal | - |
| 7 | Die attached | Conductive (Ag) | Epoxy resin |
| 8 | Bonding wire | Au | Pad 1 options : NC is 5 wires , EN is 6 wires. |

■ PACKAGE INFORMATION

▶ TAPE (CARRIER) DIMENSIONS

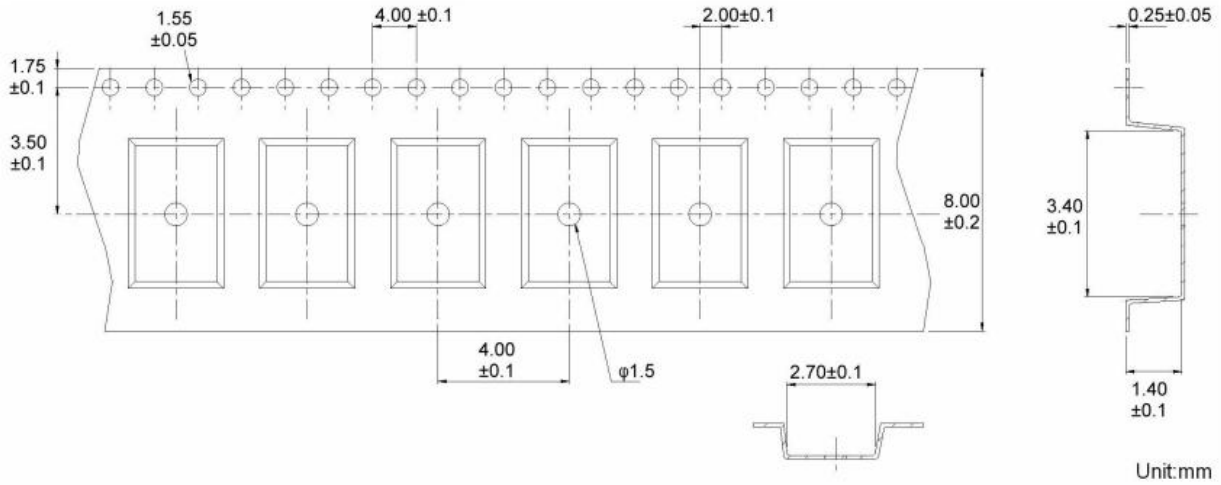

▶ THE DIRECTION OF PACKING

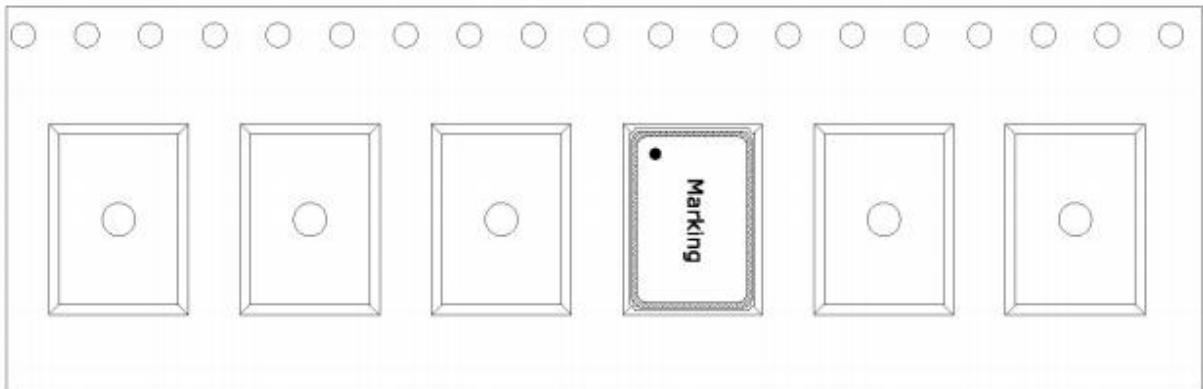

▶ REEL DIMENSIONS

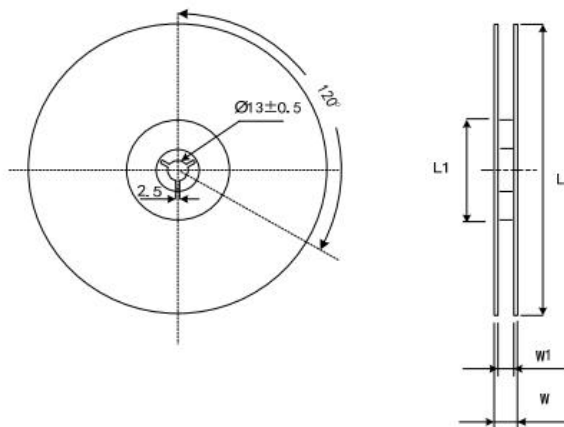

| DIMENSIONS | L | L1 | W | W1 | Standard Reel Quantity is 3,000 pcs per reel (UNIT:mm) |
|------------|--------------|---------------|--------------|------------|---|
| | 178 ±1.00 | 60.2 ±0.50 | 11.5 ±0.2 | 8 +1/-0 | |

■ RELIABILITY SPECIFICATIONS

1. Mechanical Endurance

| No. | Test Item | Test Methods | REF. DOC |
|-----|------------------|---|-------------|
| 1 | Drop Test | 75 cm height, 3 times on concrete floor . | JIS C6701 |
| 1 | Mechanical Shock | Device are shocked to half sine wave (1000 G) three mutually perpendicular axes each 3 times. 0.5m sec. duration time | MIL-STD-202 |
| 1 | Vibration | Frequency range 10 ~ 2000 Hz Amplitude 1.52 mm/20G Sweep time 20 minutes perpendicular axes each test time 4 Hrs (Total test time 12 Hrs) | MIL-STD-883 |
| 1 | Gross Leak | Standard Sample For Automatic Gross Leak Detector, Test Pressure: 2kg / cm ² | MIL-STD-883 |
| 2 | Fine Leak | Helium Bomging 4.5 kgf / cm ² for 2 Hrs | MIL-STD-883 |
| 2 | Solderability | Temperature 245 °C ± 5°C Immersing depth 0.5 mm minimum Immersion time 5 ± 1 seconds Flux Rosin resin methyl alcohol solvent (1 : 4) | MIL-STD-883 |

2. Environmental Endurance

| No. | Test Item | Test Methods | REF. DOC |
|-----|------------------------------|--|-------------|
| 2 | Resistance To Soldering Heat | Pre-heat temperature 125 °C Pre-heat time 60 ~ 120 sec. Test temperature 260 ± 5 °C Test time 10 ± 1 sec. | MIL-STD-202 |
| 2 | High Temp. Storage | + 125 °C ± 3 °C for 1000 ± 12 Hrs | MIL-STD-883 |
| 2 | Low Temp. Storage | - 40 °C ± 3 °C for 1000 ± 12 Hrs | |
| 2 | Thermal Shock | Total 100 cycles of the following temperature cycle  | MIL-STD-883 |
| 3 | High Temp & Humidity | 85°C ± 3°C, RH 85% , 1000 Hrs | EIA-JESD22 |
| 3 | Pressure Cooker Storage | 121 ± 3°C , RH100% , 2 bar , 240 Hrs | EIA-JESD22 |

单击下面可查看定价，库存，交付和生命周期等信息

[>>JGHC\(晶光华\)](#)