

# 承 认 书

## SPECIFICATION FOR APPROVAL

客户名称: Customer 世强

货 名: Description SMD6035 石英晶体谐振器

客户料号: Part No \_\_\_\_\_

物料编号: Code No S6316000202040

频 率: Frequency 16.000MHz

日 期: Date 2020-06-12

备 注: RoHS compliance with Directive (EU) 2015/863

制作(Prepare by)	检查(Check by)	批准 (Approve by)
江丹娜	甘瑛	张刚

客户批准 Approve by customer	
批准日期 Approval date	

Add:广东省深圳市华发北路桑达工业区桑达雅苑 7P

7 P Sangda Yayuan Huafa North Road, Futian District, Shenzhen, Guangdong

Tel: 86-755-83048260      86-755-83048290

Fax: 86-755-83048280

## 1、 Specifications

1	规格型号 <b>Holder Type</b>	SMD6035
2	标称频率 <b>Nominal Frequency</b>	16.000MHz
3	振动模式 <b>Mode of Oscillation</b>	Fundamental
4	调整频差 <b>Frequency Tolerance at 25℃</b>	±20ppm
5	温度频差 <b>Temperature Frequency Stability</b>	±30ppm
6	工作温度 <b>Operating Temperature Range</b>	-40~85℃
7	贮存温度 <b>Storage Temperature Range</b>	-40~90℃
8	负载电容 <b>Load Capacitance</b>	20pf
9	静电容 <b>Shunt capacitance</b>	≤7 pf
10	等效电阻 <b>Equivalent Series Resistance</b>	40Ω Max
11	激励功率 <b>Drive Level</b>	10uW
12	绝缘阻抗 <b>Insulation Resistance</b>	500MΩ/100V±15V <sub>DC</sub>
13	年老化率 <b>Aging</b>	±3ppm/First year
14	测试仪器 <b>Test machine</b>	250B

## 2.Frequency stability over temperature range (AT cut)

Temperature Range	Frequency Stability							
	±3PPM	±5PPM	±7.5PPM	±10PPM	±20PPM	±30PPM	±50PPM	±70PPM
0℃~+50℃	☆	☆	☆	☆	☆	☆	☆	☆
-10℃~+60℃			☆	☆	☆	☆	☆	☆
-20℃~+70℃				☆	☆	☆	☆	☆
-30℃~+70℃					☆	☆	☆	☆
-40℃~+85℃						☆	☆	☆
-40℃~+125℃						☆	☆	☆

### 3. Dimensions (unit:mm)

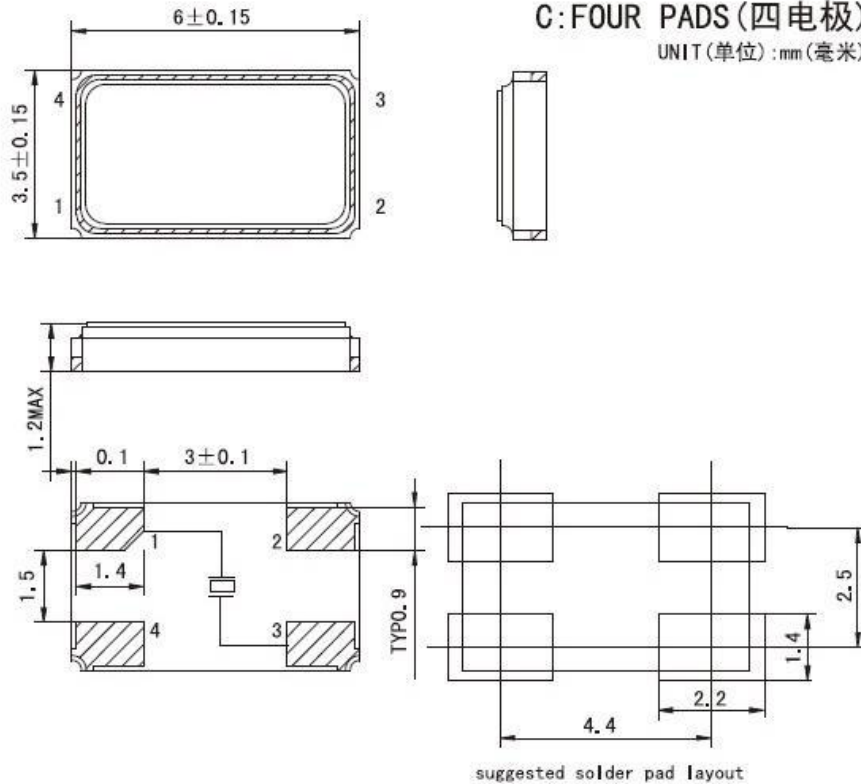

Note) #2, #4 is connected with a cover  
(Please connect with a GND or a power supply)

### 4.Recommended Reflow profile

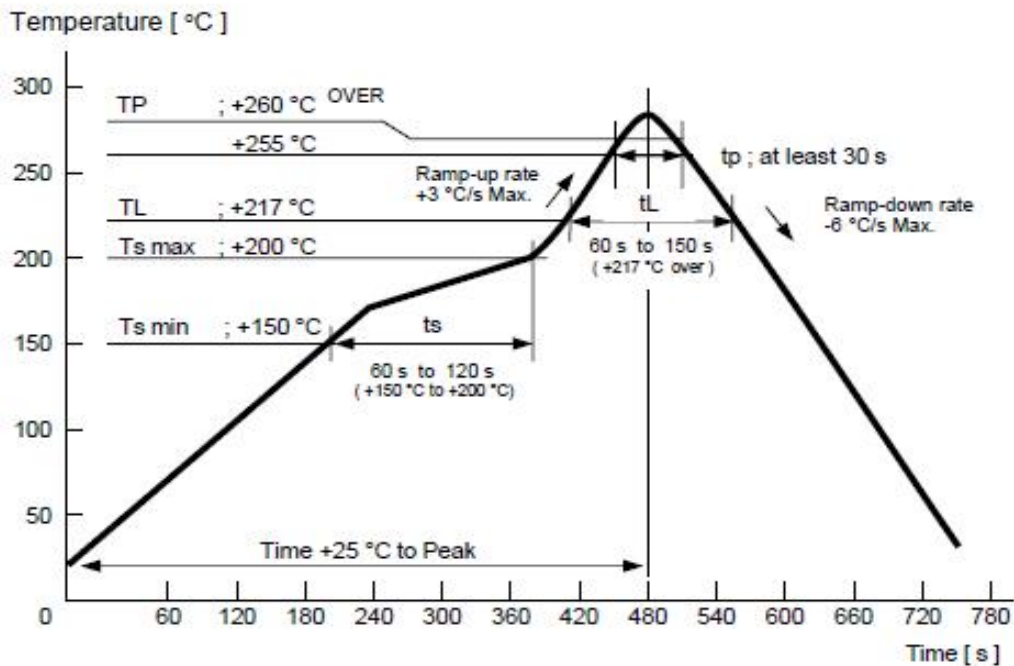

## 5、Reliability specifications

NO	Item	Condition	Standard
1.	Drop Test	Free drop from 50cm height on a hard wooden board for 3 times. (Board is thickness more than 30 mm.)	Frequency change: ≤5ppm Rr as specification
2.	Mechanical Shock	Half sine wave, 1000G, 0.5mS, three times for all 3 directions	Frequency change: ≤5ppm Rr as specification
3.	Vibration	Frequency range:10~55hz Amplitude:1.52mm Sweep time:1mintutes perpendicular axes each test time:2Hrs	Frequency change: ≤5ppm Rr as specification
4.	Solderability	Temperature:245℃±5℃ Immersing depth:0.5mm minimum Immersion time:5±1sec. Flux:Rosin resin methyl alcohol solvent(1:4)	90% exhibit tin ok
5.	Resistance to soldering heat	Test temperature:260℃±5℃ Test time :10±1sec.	Frequency change: ≤10ppm Rr as specification
6.	High Temp & Humidity	85±3℃ & RH85%, 500±12 hours	Frequency change: ≤10ppm Rr as specification
7.	Low temperature storage	-40±3℃, 500±12 hours	Frequency change: ≤10ppm Rr as specification
8.	High temperature storage	+85±3℃, 500±12 hours	Frequency change: ≤10ppm Rr as specification
9.	Temperature cycling	-40±3℃/10min~+85±3℃/10min, 100cycles	Frequency change: ≤10ppm Rr as specification

### 6、Packaging standard

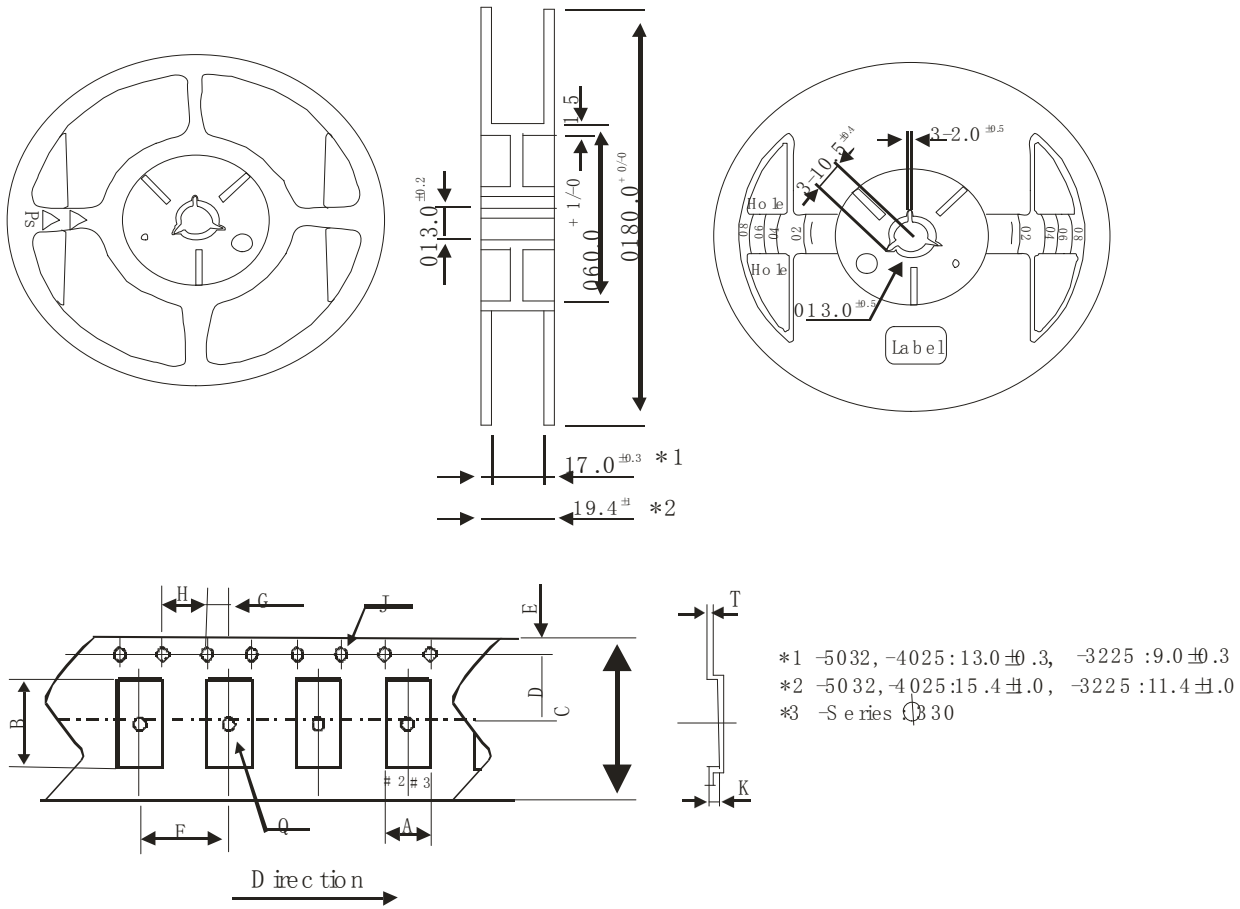

- Standard quantity of ST -3225 : 3,000 pcs/reel
- Standard quantity of SN -Series : 4,000 pcs/reel
- Standard quantity of others : 1,000 pcs/reel
- Carrier tape : Antistatic material (PS)
- Each reel can be recycled

	SJ-7050 SN-7050	SJ-6032 SN-6032	SJ-5032	SJ -5032	SJ-4025	SJ-3225
A	5.4±0.1	3.9±0.1	3.5±0.1	3.5±0.1	2.9±0.1	2.9±0.1
B	7.4±0.1	6.4±0.1	5.4±0.1	5.4±0.1	4.4±0.1	3.6±0.1
C	16.0±0.2	16.0±0.2	12.0±0.2	12.0±0.2	10.0±0.2	8.0±0.2
D	7.5±0.1	7.5±0.1	5.5±0.1	5.5±0.1	5.5±0.1	5.5±0.1
E	1.75±0.1	1.75±0.1	1.75±0.1	1.75±0.1	1.75±0.1	1.75±0.1
F	8.0±0.1	8.0±0.1	8.0±0.1	8.0±0.1	4.0±0.1	4.0±0.1
G	2.0±0.1	2.0±0.1	2.0±0.1	2.0±0.1	2.0±0.1	2.0±0.1
H	4.0±0.1	4.0±0.1	4.0±0.1	4.0±0.1	4.0±0.1	4.0±0.1
J	1.55±0.05	1.55±0.05	1.5±0.1/0	1.5±0.1/0	1.5±0.1/0	1.5±0.1/0
K	1.4±0.1	1.5±0.1	1.0±0.1	1.5±0.1	0.9±0.1	0.9±0.1
Q	1.6±0.1/0	1.55±0.05	1.6±0.1	1.6±0.1	1.5±0.1/0	1.5±0.1/0
T	0.3±0.05	0.3±0.05	0.25±0.05	0.25±0.05	0.25±0.05s	0.25±0.05s

Item		Empty Space
Tapa Leader	Cover Tape	Min.500mm
	Empty Pockets	Min.20 pockets
Tape Trailer	Cover Tape	Min.0mm
	Empty Pockets	Min.40mm

### 7. Inner carton

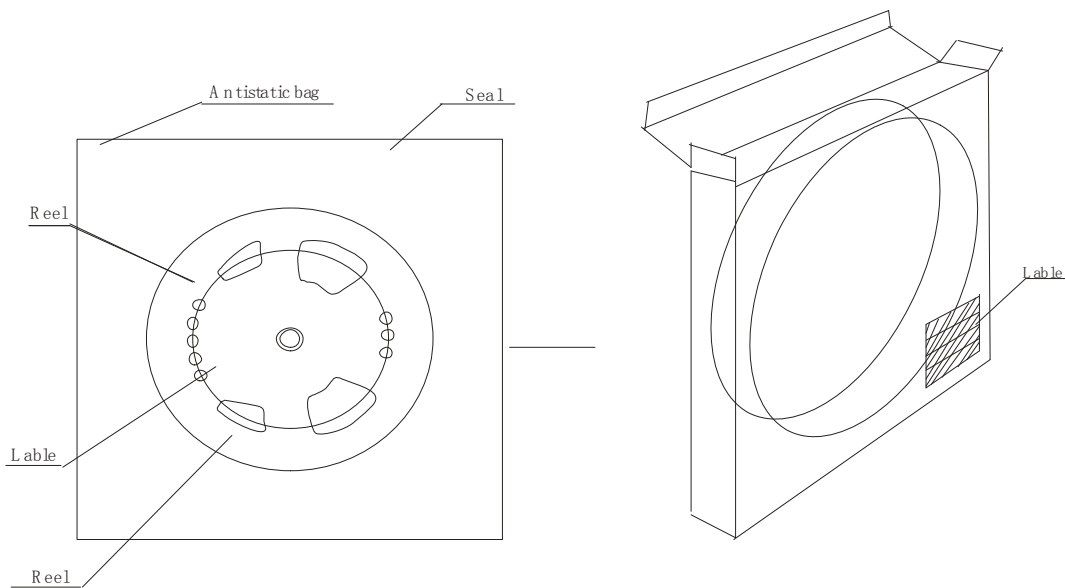

### OUTET CARTON

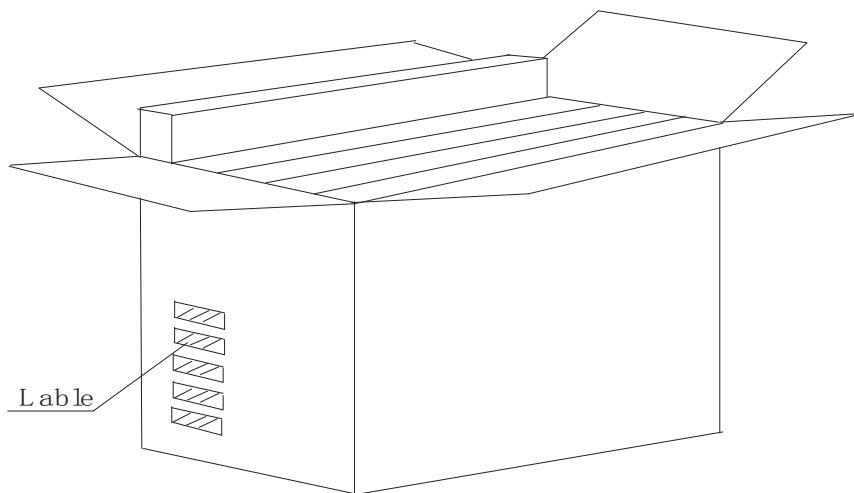

## 7-1. MARKING

- (1) Marking Labels are affixed to reel, inner carton and outer carton.
- (2) Each label contains the following information.
  - (a) Manufacture's name or symbol
  - (b) Parts name or type
  - (c) Frequency
  - (d) Quantity
  - (e) Reel number
  - (f) Manufacturer's code (EIAJ code)

## 7-2. QUANTITY

1000pcs/reel (max.5reels in outer carton)

## 7-3. STORAGE ENVIRONMENT

- ✧ Storage the reel at normal temperature and humidity
- ✧ Open the packing just before using
- ✧ Do not expose the sun
- ✧ Do not storage with some erosive chemicals
- ✧ Nothing is allowed to put on the reel or carton to prevent mechanical damage

## 7-4. HANDLING

- ✧ Handle with care to prevent the damage of tape, reel and products.

单击下面可查看定价，库存，交付和生命周期等信息

[>>JGHC\(晶光华\)](#)