

承 认 书

SPECIFICATION FOR APPROVAL

客户名称: Customer _____

货 名: Description SMD TSX2.5*2.0 (热敏晶振)

客户料号: Part No _____

物料编号: Code No TSX2226000091040频 率: Frequency 26.000MHz日 期: Date 2020-05-26备 注: RoHS compliance with Directive (EU) 2015/863

制作(Prepare by)	检查(Check by)	批准 (Approve by)
江丹娜	甘瑛	张刚

客户批准 Approve by customer	
批准日期 Approval date	

Add: 广东省深圳市华发北路桑达工业区桑达雅苑 7P

7 P Sangda Yayuan Huafa North Road, Futian District, Shenzhen, Guangdong

Tel: 86-755-83048260

86-755-83048290

Fax: 86-755-83048280

■ ELECTRICAL SPECIFICATIONS

Standard atmospheric conditions

Unless otherwise specified, the standard range of atmospheric conditions for making measurement and tests are as follow:

Ambient temperature : 25±5℃

Relative humidity : 40%~70%

If there is any doubt about the results, measurement shall be made within the following limits:

Ambient temperature : 25±3℃

Relative humidity : 40%~70%

Measure equipment

Electrical characteristics measured by S&A250B or equivalent.

Crystal cutting type

The crystal is using AT CUT (thickness shear mode).

■ ELECTRICAL SPECIFICATIONS

ELECTRICAL SPECIFICATIONS

NO.	Parameters	Symbol	Condition	Electrical Spec.				Note
				Min.	Typ.	Max.	Units	
1	Nominal Frequency	FL	-	26.000000			MHz	
2	Oscillation Mode	-	-	Fundamental				
3	Load Capacitance	CL	-	-	9	-	pF	
4	Frequency Tolerance	-	+25℃ ± 3℃	±10			ppm	
5	Frequency Stability Over Operating Temp. Range(Reference 25℃)	-	-25℃to +85℃	±10			ppm	
6	Aging	-	first year	-	-	±1.0	ppm/year	
		-	second year	-	-	±1.5	ppm/2year	
		-	after 5 years	-	-	±2.5	ppm/5year	
		-	after 10 years	-	-	±5.0	ppm/10year	
7	Frequency drift after reflow (After two reflows)	-	-	-	-	±2	ppm	After two reflows (0.5Hr freq. drift substruct 168Hr freq. drift
8	Drive Level	DL	-		50		μW	
9	Equivalent Series Resistance	ESR	-	-	-	40	Ω	
10	Spurious Mode Resistance	-	±1 MHz	500	-	-	Ω	
11	Insulation Resistance	-	at DC 100V	500	-	-	MΩ	
12	Q Factor	-		75000	-	-	-	
13	Operating Temperature	-		-30	-	+85	℃	
14	Storage Temperature Range	-		-40	-	+85	℃	
15	Pulling Sensitivity	TS		16.2	18.0	19.8	ppm/pF	

■ ELECTRICAL SPECIFICATIONS

NO.	Parameters	Symbol	Condition	Electrical Spec.				Note
				Min.	Typ.	Max.	Units	
16	Inflection point	Ti		27	28.5	30	°C	
17	Room temperature	To			28.5		°C	
18	1st order coefficient	C1		-0.35	-0.225	-0.1	ppm/°C	(Note 1)
19	2nd order coefficient	C2		-12.0	-8.5	-5.0	x10-4ppm/°C ²	
20	3rd order coefficient	C3		8.7	9.9	11	x10-5ppm/°C ³	
21	Frequency stability slope 1	-		-0.05	-	0.05	ppm/°C	at -10~+60°C (Note 2)
22	Frequency stability slope 12	-		-0.05	-	0.05	ppm/°C	at -30~+85°C (Note 2)
23	G Sensitivity			-2.0		2.0	ppb/G	
24	Full Cycle Temperature Hysteresis	-		-0.5	-	0.5	ppm/°C	at -40~+85°C (Note 3)
25	Small Cycle Temperature Hysteresis	-		-0.05	-	0.05	ppm/°C	(Note 4)
26	Perturbation	-		-0.5	-	0.5	ppm/°C	(Note 5)
29	DLD Freq (Max-Min)	FDLD		-	-	2.0	ppm	(Note 6)
30	DLD Freq (Repeatability)	FDLDH		-	-	0.7	ppm	
31	DLD ESR (Max-Min)	DLD2		-	-	2.5	ohms	
32	DLD ESR (Repeatability)	DLDH2		-	-	1.5	ohms	

Note 1 S curve (FL) 3rd order curve fitting coefficient requirement over operation temperature under 2°C test.
[F(T) = C3(T-To)³ + C2(T-To)² + C1(T-To) + C0; To = 25°C] ;

Note 2 Frequency slope error between measured S curve (FL) data and 3rd order curve fitting data over temperature under per 2°C test. (Continuous temperature rate change of 1.0°C/min) ;

Note 3 Difference in frequency measurement at any temperature when undergoing a thermal cycle over the entire operation temperature range from -40°C to 85°C per 2°C test;

Note 4 Difference in frequency measurement at any temperature when undergoing a thermal cycle of a temperature range of 5°C per 1°C test;

Note 5 Residual error from the frequency vs. temperature curve fit 5th order. Minimum of frequency reading every 3°C over operation temperature;

Note 6 DLD Sweep: 10nW to 100uW to 10nW

■ NTC THERMISTOR SPECIFICATIONS TABLE

NO.	Parameters	Symbol	Condition	Electrical Spec.				Note
				Min.	Typ.	Max.	Units	
1	Resistance (25 °C)			100k ± 1%			Ω	
2	B-Constant (25-50 °C)			4250 ± 1%			K	1
3	Tolerance			-1		1	%	

Note 1 The B constant is calculated using the zero-power resistance values measured at 25°C and 50°C

■ DIMENSIONS

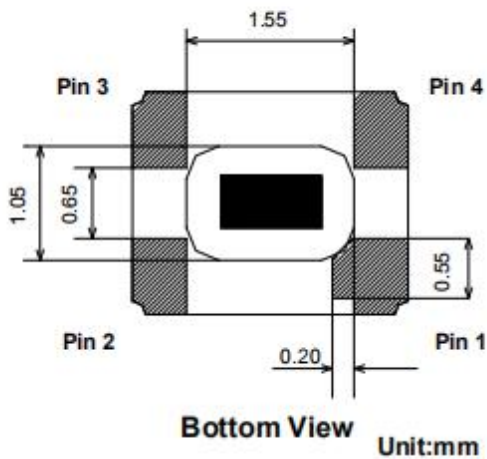
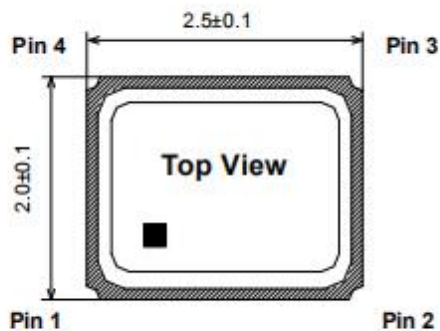

■ PIN FUNCTION

	Symbol	Function
Pin 1	XT1	XTAL Terminal 1
Pin 2	RT2	Thermistor Terminal 2
Pin 3	XT2	XTAL Terminal 2
Pin 4	RT1	Thermistor Terminal 1

Note: Pin 2 is connected to the metal lid and thermistor
Pin 4 is connected to the thermistor only

■ BLOCK DIAGRAM

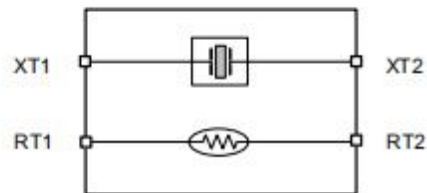

Note: RT2 shall be connected to GND is recommended

■ SUGGESTED LAYOUT

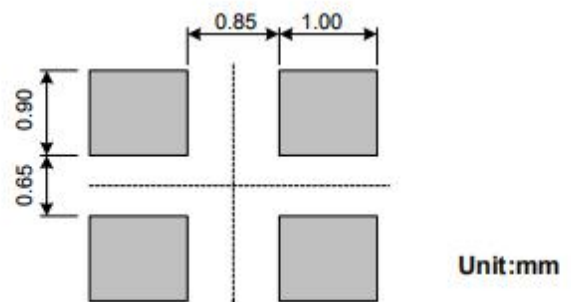

■ SUGGESTED REFLOW PROFILE

Total time : 360 sec. Max.

Solder melting point :225 °C

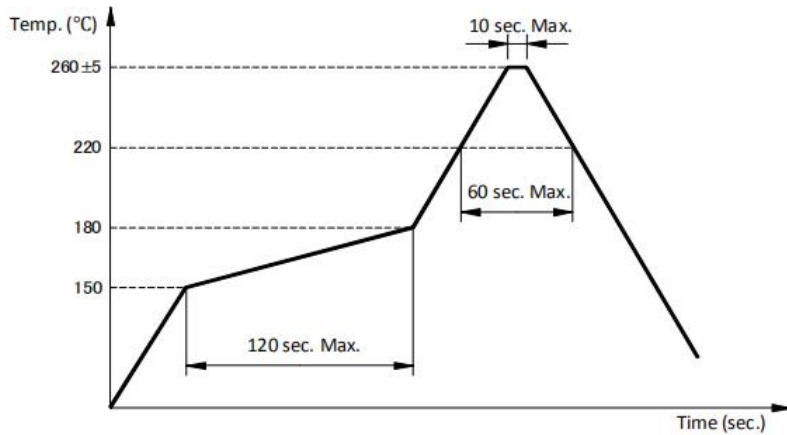

■ STRUCTURE ILLUSTRATION

Crystal Enclosure Seal : Seam Welding

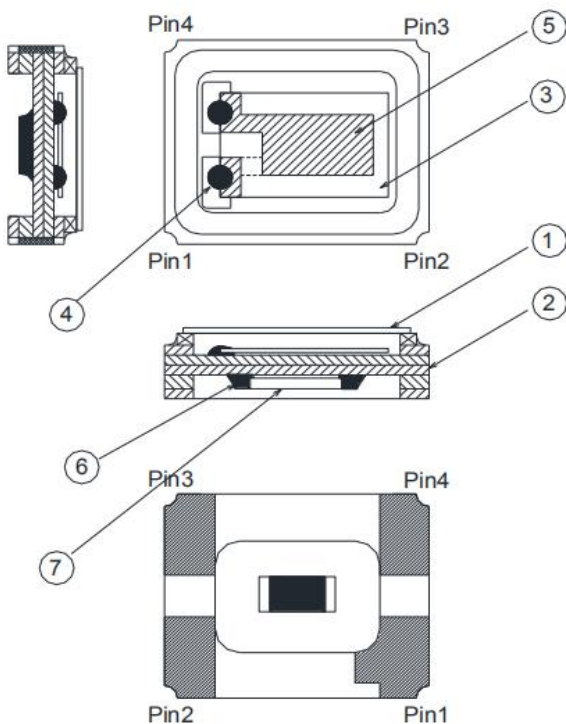

No.	COMPONENTS	MATERIALS	FINISH/SPECIFICATIONS
1	Lid	Metal (Fe+Co+Ni)	-
2	Base (Package)	Ceramic (Al ₂ O ₃) + Kovar (Fe+Co+Ni) + Ag/Cu	Alumina Ceramics
3	Crystal Blank	SiO ₂	-
4	Conductive Adhesive	Ag	Silicone Resin
5	Electrode	Noble Metal	-
6	Solder	Sn	-
7	Thermistor	Al ₂ O ₃ , Ag, Ni	-

RELIABILITY SPECIFICATIONS

1. Mechanical Endurance

No.	Test Item	Test Methods	Reference
1.1	Drop Test	150 cm height, 3 times on concrete floor.	JIS C6701
1.2	Mechanical Shock	Device are shocked to half sine wave (1000 G) three mutually perpendicular axes each 3 times. 0.5 msec. duration time	MIL-STD-202
1.3	Vibration	Frequency range 10 ~ 2000 Hz Amplitude 1.52 mm/20 G Sweep time 20 minutes Perpendicular axes each test time 4 Hrs (Total test time 12 Hrs)	MIL-STD-883
1.4	Gross Leak	Standard sample for automatic gross leak detector Test pressure: 2 kg / cm ²	MIL-STD-883
1.5	Fine Leak	Helium bombing 4.5 kg/ cm ² for 2 Hrs	
1.6	Solderability	Temperature 245°C ± 5°C Immersing depth 0.5 mm minimum Immersion time 5 ± 1 seconds Flux Rosin resin methyl alcohol solvent (1 : 4)	MIL-STD-883

2. Environmental Endurance

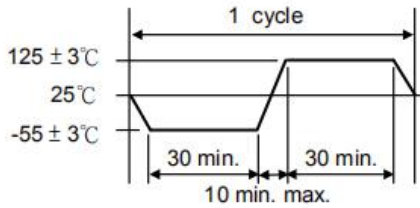
No.	Test Item	Test Methods	Reference
2.1	Resistance To Soldering Heat	Pre-heat temperature 125°C Pre-heat time 60 ~ 120 sec. Test temperature 260 ± 5°C Test time 10 ± 1 sec.	MIL-STD-202
2.2	High Temp. Storage	+ 125 °C ± 3 °C for 500 ± 12 Hrs	MIL-STD-883
2.3	Low Temp. Storage	- 40°C ± 3°C for 500 ± 12 Hrs	
2.4	Thermal Shock	Total 100 cycles of the following temperature cycle 	MIL-STD-883
2.5	High Temp & Humidity	85°C ± 3°C, RH 85% , 500 Hrs	JIS C5023



深圳市晶光华电子有限公司
ShenZhen JingGuangHua Electronic Co.,Ltd.



单击下面可查看定价，库存，交付和生命周期等信息

[>>JGHC\(晶光华\)](#)