

承 认 书

SPECIFICATION FOR APPROVAL

客户名称: Customer _____

货 名: Description Y2*6 石英晶体谐振器

客户料号: Part No _____

物料编号: Code No Y20600327122075

频 率: Frequency 32.768KHz

日 期: Date 2020-05-22

备 注: RoHS compliance with Directive (EU) 2015/863

制作(Prepare by)	检查(Check by)	批准 (Approve by)
江丹娜	甘瑛	张刚

客户批准 Approve by customer	
批准日期 Approval date	

Add: 广东省深圳市华发北路桑达工业区桑达雅苑 7P

7 P Sangda Yayuan Huafa North Road, Futian District, Shenzhen, Guangdong

Tel: 86-755-83048260

86-755-83048290

Fax: 86-755-83048280

1、 Specifications

1	规格型号 Holder Type	Y2*6
2	标称频率 Nominal Frequency	32.768KHz
3	振动模式 Mode of Oscillation	基频
4	调整频差 Frequency Tolerance at 25°C	±20ppm
5	温度频差 Temperature Frequency Stability	-0.04 × 10 ⁻⁶ ppm / °C ² Max..
6	工作温度 Operating Temperature Range	-20~70°C
7	贮存温度 Storage Temperature Range	-40~85°C
8	负载电容 Load Capacitance	12.5pf
9	静电容 Shunt capacitance	≤3pf
10	等效电阻 Equivalent Series Resistance	75K Ω Max
11	激励功率 Drive Level	0.1uW
12	绝缘阻抗 Insulation Resistance	500MΩ min./DC100V
13	年老化率 Aging	±3ppm/First year

2.Dimensions (unit:mm)

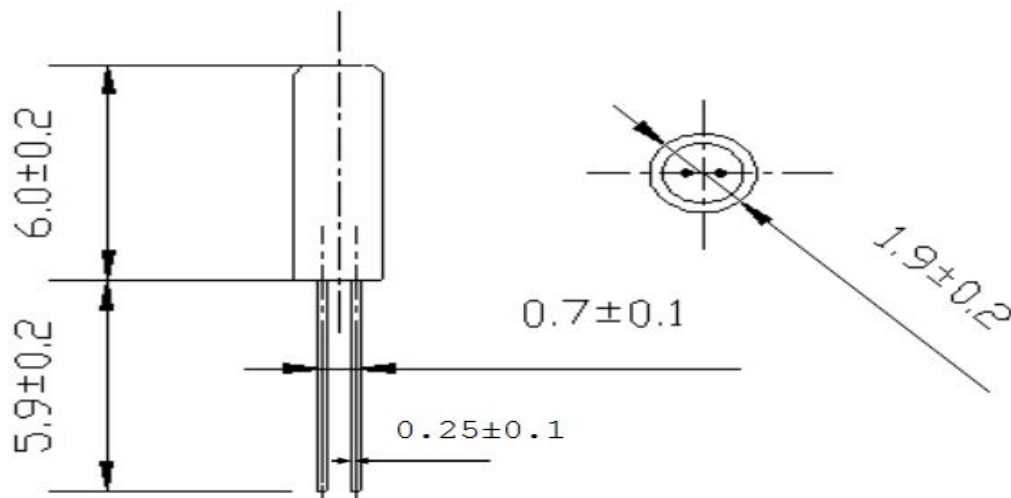

3.Suggested soldering

- 4.1 Not recommended reflow soldering.
- 4.2 lead wire should be soldered within 3seconds with the iron heated to a temperature no higher than 380°C.
- 4.3 in sold-dip mounting,ti should be soldered with 10 seconds no higher than 260°C.

5、Reliability specifications

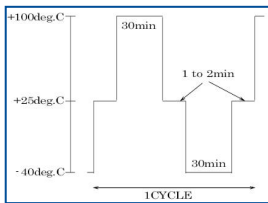
NO	Item	Condition	Standard
1.	Vibration	(1)Vibration Frequency 10 to 55Hz (2)Vibration Amplitude 1.5mm (3) Cycle Time 1-2min(10-55-10Hz) (4)Direction X.Y.Z (5)Duration 2h/each direction	Frequency Change:±5ppm Max. Resistance Change: 5kohm Max.
2.	Shock	3 Times free drop from 75cm height to hard wooden board of thickness more than 30mm	Frequency Change:±5ppm Max. Resistance Change: 5kohm Max.
3.	Hermetic seal	Helium leak detector Checked:before the molded crystal units	less than 1×10^{-7} mbar.l/sec.
4.	Solder ability	Dip the leads of crystal units into the solution (7-10%) of rosin 3±0.5s,then dip it into the tank 5-10s.Temperature of solder melted tank is 245°C ±5°C	The dipped surface of the leads should be at least 95% covered with continuous new solder coating
5.	High temperature	96 hours at +100°C ±2°C After 1-2hours past at room temperature from following	Frequency Change:±5ppm Max. Resistance Change: 5kohm Max.
6.	Low temperature	72 hours at -40°C ±2°C After 1-2hours past at room temperature from following test.	Frequency Change:±5ppm Max. Resistance Change: 5kohm Max.
7.	Humidity	96 hours at +40°C ±2°C ,relative humidity 90-95%After 1-2hours past at room temperature from following	Frequency Change:±5ppm Max. Resistance Change: 5kohm Max.
8.	Temperature cycle	After supplying the following temperature cycle (50cycles) 	Frequency Change:±5ppm Max. Resistance Change: 5kohm Max.
9.	salt spray test	On the basis of GB/T10125-1997	Frequency Change:±5ppm Max. Resistance Change: 5kohm Max.
10.	Lead strength	In the lead 2.00 Kg tensile force was applied at the end to keep more than 5 seconds	Frequency Change:±5ppm Max. Resistance Change: 5kohm Max.

6、Packaging standard

Dimension of Inside Package

内包装尺寸图

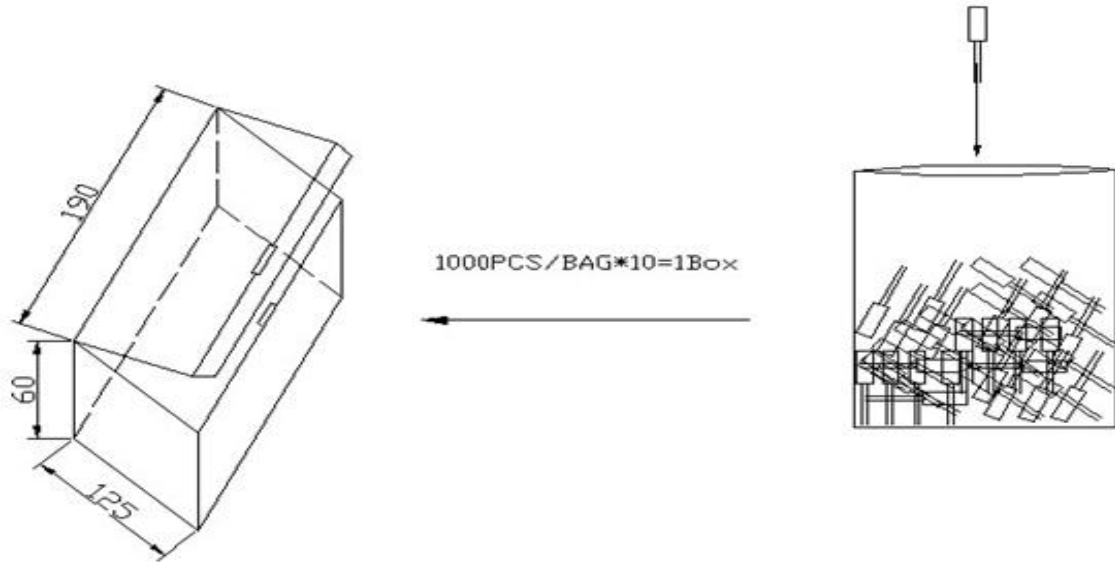

Dimensions of outside Package

10 inner box=1 outer box

外包装尺寸图

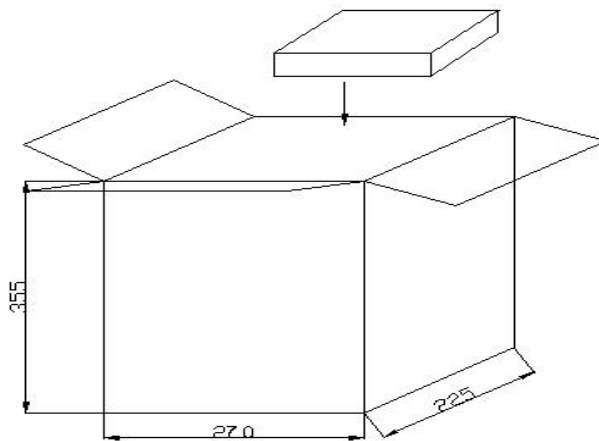

7、 Handling Notice for Standard Tuning Fork Crystal (Cylindrical Type)

7.1. Shock resistance

It may deteriorate the characteristics or cause of no oscillation if excess physical shock given. Please be careful not to drop. Please use under condition to minimize the shocks as much as possible.

Please review the conditions if it is used by auto mounting or after the conditions are changed.

7.2. Heat and humidity resistance in storage

Storing the crystal products under higher or lower temperature or high humidity for a long period may deteriorate the characteristics of crystal units.

Please store and use the crystal products at the normal temperature and humidity.

7.3. Solder heat resistance

Standard type crystal products use Material have a 230°C melting point. Heating up the package more than 230°C may deteriorate the characteristics or cause of no oscillation the products. If the crystal products need to be soldered at temperature of more than +230°C, please study heat-resistance products or SMD products.

Please review the condition or consult us about flow solder process.

7.4. Mounting method to PCB

When the crystal products need to be lay down please fix to PCB securely.

If the crystal is used with mechanical vibration location, please put cushion in between PCB or fix with elasticity glue (Silicon etc) as shown in below figure.

Please don't gluing hermetic seal grass. When the crystal products need to be mounted vertically, gap between crystal units and PCB more than 3mm for 3×8 type , more than 2mm for 2×6 type is recommended.

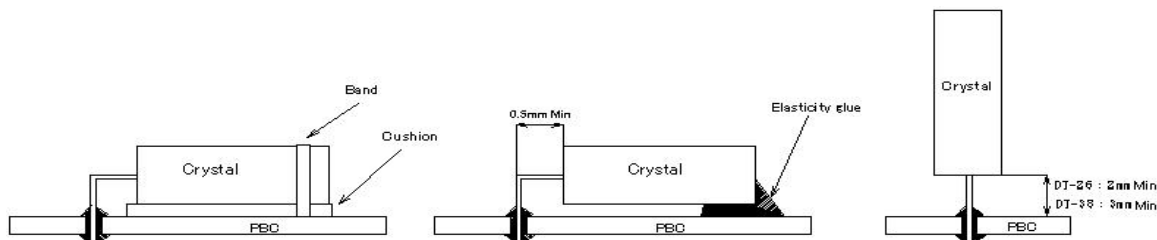

7.5. Lead process

When the lead needs to be cut please maintenance the cutter.

When the lead needs to be bent or repaired please be careful not to giving excess pressure at the root of the lead to avoid crack of the hermetic seal glass. Also please be careful not to giving excess pressure at sealing to avoid sealing tightness deteriorate. Leave more than 0.5 mm of lead from the case.

7.6 Ultrasonic cleaning and ultrasonic soldering

Soldered by ultrasonic cannot be guaranteed, because crystal may be sympathetic vibrated and may damage. Please study at your side about ultrasonic cleaning.

7.7. Drive level

Applying excessive drive level to the crystal units may cause deterioration of characteristics or damage. Less than 1.0μW is recommended to this products.

More than 2.0μW cannot be guaranteed.

单击下面可查看定价，库存，交付和生命周期等信息

[>>JGHC\(晶光华\)](#)

[>>点击查看相关商品](#)