



JCT1025/1225 Series 25A SCRs

Rev.6.0

DESCRIPTION:

With high ability to withstand the shock loading of large current, JCT1025/JCT1225 SCRs provide high dv/dt rate with strong resistance to electromagnetic interference. They are especially recommended for use on solid state relay, motorcycle, power charger, T-tools etc.

From all three terminals to external heatsink, JCTxx25A provides a rated insulation voltage of 2500 V_{RMS}, and JCTxx25F provides a rated insulation voltage of 2000 V_{RMS}, complying with UL standards (File ref: E252906).

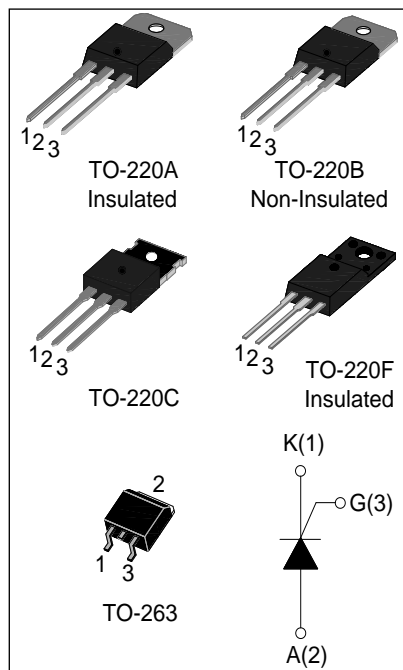

MAIN FEATURES

Symbol	JCT1025	JCT1225
V _{DRM} / V _{R_{RM}}	1000V	1200V
I _{T(RMS)}	25A	
I _{GT}	≤ 40mA	

ABSOLUTE MAXIMUM RATINGS

Parameter	Symbol	Value	Unit	
Storage junction temperature range	T _{stg}	-40-150	°C	
Operating junction temperature range	T _j	-40-125	°C	
Repetitive peak off-state voltage(T _j =25°C)	V _{DRM}	1000/1200	V	
Repetitive peak reverse voltage(T _j =25°C)	V _{R_{RM}}	1000/1200	V	
Non repetitive surge peak Off-state voltage	V _{D_{SM}}	V _{DRM} +100	V	
Non repetitive peak reverse voltage	V _{R_{SM}}	V _{R_{RM}} +100	V	
RMS on-state current	TO-220A (Ins)/ TO-220F(Ins) (T _C =85°C)	I _{T(RMS)}	25	A
	TO-220B (Non-Ins)/ TO-220C(T _C =100°C)			
	TO-263 (T _C =105°C)			

Non repetitive surge peak on-state current (tp=10ms)	I_{TSM}	300	A
I^2t value for fusing (tp=10ms)	I^2t	450	A^2s
Critical rate of rise of on-state current ($I_G=2 \times I_{GT}$)	dl/dt	150	$A/\mu s$
Peak gate current	I_{GM}	4	A
Average gate power dissipation	$P_{G(AV)}$	2	W
Peak gate power	P_{GM}	5	W

ELECTRICAL CHARACTERISTICS ($T_j=25^\circ C$ unless otherwise specified)

Symbol	Test Condition	Value			Unit
		MIN.	TYP.	MAX.	
I_{GT}	$V_D=12V R_L=33\Omega$	-	-	40	mA
V_{GT}		-	-	1.5	V
V_{GD}	$V_D=V_{DRM} T_j=125^\circ C R_L=3.3K\Omega$	0.2	-	-	V
I_L	$I_G=1.2I_{GT}$	-	-	140	mA
I_H	$I_T=500mA$	-	-	120	mA
dV/dt	$V_D=2/3V_{DRM}$ Gate Open $T_j=125^\circ C$	1000	-	-	$V/\mu s$

STATIC CHARACTERISTICS

Symbol	Parameter		Value(MAX)	Unit
V_{TM}	$I_{TM}=50A tp=380\mu s$	$T_j=25^\circ C$	1.6	V
I_{DRM}	$V_D=V_{DRM} V_R=V_{RRM}$	$T_j=25^\circ C$	10	μA
I_{RRM}		$T_j=125^\circ C$	4	mA

THERMAL RESISTANCES

Symbol	Parameter		Value	Unit
$R_{th(j-c)}$	junction to case(AC)	TO-220A(Ins)	1.4	$^\circ C/W$
		TO-220B (Non-Ins) / TO-220C	0.85	
		TO-220F(Ins)	1.5	
		TO-263	0.75	

ORDERING INFORMATION

<p>JieJie Microelectronics Co.,Ltd</p>	<p>J</p>	<p>CT</p>	<p>12</p>	<p>25</p>	<p>B</p>
		<p>SCRs</p>			<p>E:TO-263 C:TO-220C A:TO-220A(Ins) F:TO-220F(Ins) B:TO-220B (Non-Ins)</p>
		<p>10:V_{DRM}/V_{RRM}≥1000V 12:V_{DRM}/V_{RRM}≥1200V</p>			<p>I_{T(RMS)}:25A</p>

PACKAGE MECHANICAL DATA

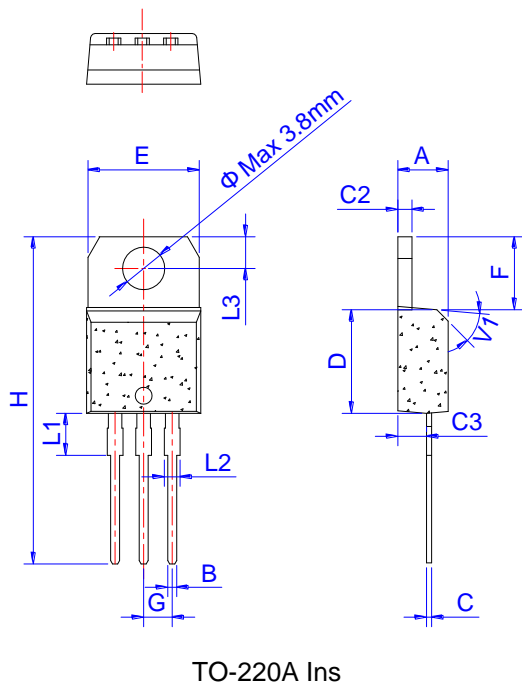

Ref.	Dimensions					
	Millimeters			Inches		
	Min.	Typ.	Max.	Min.	Typ.	Max.
A	4.40		4.60	0.173		0.181
B	0.61		0.88	0.024		0.035
C	0.46		0.70	0.018		0.028
C2	1.21		1.32	0.048		0.052
C3	2.40		2.72	0.094		0.107
D	8.60		9.70	0.339		0.382
E	9.80		10.4	0.386		0.409
F	6.55		6.95	0.258		0.274
G		2.54			0.1	
H	28.0		29.8	1.102		1.173
L1		3.75			0.148	
L2	1.14		1.70	0.045		0.067
L3	2.65		2.95	0.104		0.116
V1		45°			45°	

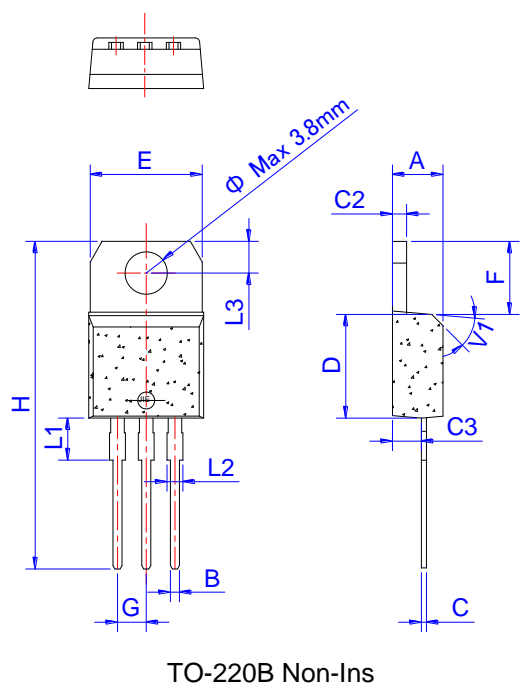

Ref.	Dimensions					
	Millimeters			Inches		
	Min.	Typ.	Max.	Min.	Typ.	Max.
A	4.40		4.60	0.173		0.181
B	0.61		0.88	0.024		0.035
C	0.46		0.70	0.018		0.028
C2	1.21		1.32	0.048		0.052
C3	2.40		2.72	0.094		0.107
D	8.60		9.70	0.339		0.382
E	9.60		10.4	0.378		0.409
F	6.20		6.60	0.244		0.260
G		2.54			0.1	
H	28.0		29.8	1.102		1.173
L1		3.75			0.148	
L2	1.14		1.70	0.045		0.067
L3	2.65		2.95	0.104		0.116
V1		45°			45°	

PACKAGE MECHANICAL DATA

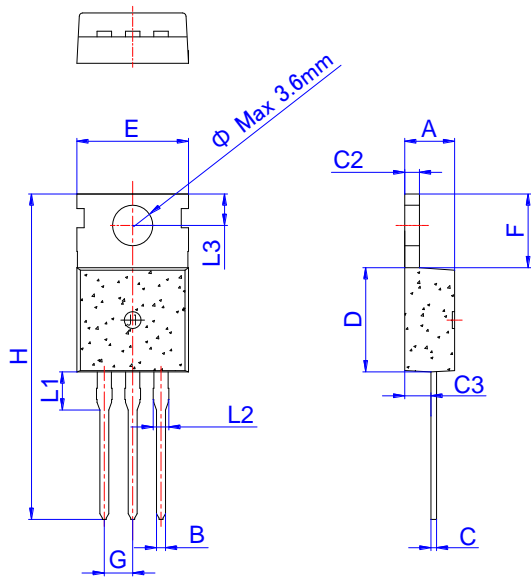

TO-220C

Ref.	Dimensions					
	Millimeters			Inches		
	Min.	Typ.	Max.	Min.	Typ.	Max.
A	4.40		4.60	0.173		0.181
B	0.70		0.90	0.028		0.035
C	0.45		0.60	0.018		0.024
C2	1.23		1.32	0.048		0.052
C3	2.20		2.60	0.087		0.102
D	8.90		9.90	0.350		0.390
E	9.90		10.3	0.390		0.406
F	6.30		6.90	0.248		0.272
G		2.54			0.1	
H	28.0		29.8	1.102		1.173
L1		3.39			0.133	
L2	1.14		1.70	0.045		0.067
L3	2.65		2.95	0.104		0.116
Φ		3.6			0.142	

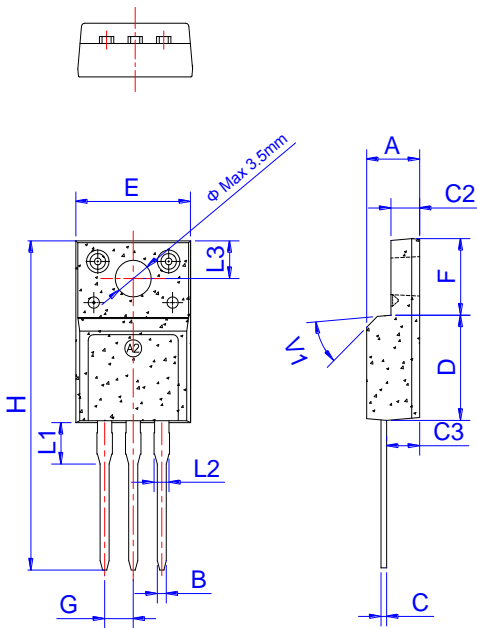

TO-220F Ins

Ref.	Dimensions					
	Millimeters			Inches		
	Min.	Typ.	Max.	Min.	Typ.	Max.
A	4.50		4.90	0.177		0.193
B	0.74	0.80	0.83	0.029	0.031	0.033
C	0.47		0.65	0.019		0.026
C2	2.45		2.75	0.096		0.108
C3	2.60		3.00	0.102		0.118
D	8.80		9.30	0.346		0.366
E	9.80		10.4	0.386		0.410
F	6.40		6.80	0.252		0.268
G		2.54			0.1	
H	28.0		29.8	1.102		1.173
L1		3.63			0.143	
L2	1.14		1.70	0.045		0.067
L3		3.30			0.130	
V1		45°			45°	

PACKAGE MECHANICAL DATA

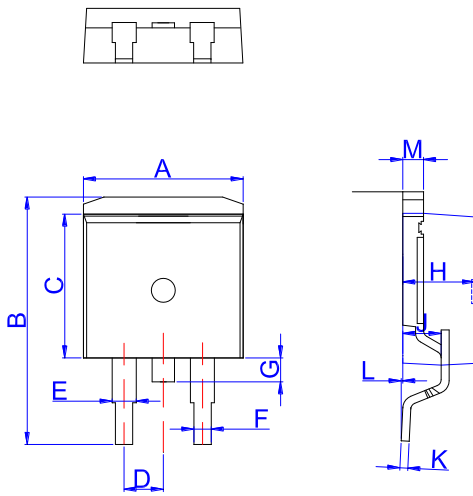

TO-263

Ref.	Dimensions					
	Millimeters			Inches		
	Min.	Typ.	Max.	Min.	Typ.	Max.
A	9.90		10.20	0.390		0.402
B	14.70		15.80	0.579		0.622
C	9.4		9.6	0.37		0.378
D		2.54			0.100	
E	1.20		1.40	0.047		0.055
F	0.75		0.85	0.029		0.033
G			1.75			0.069
H	4.40		4.70	0.173		0.185
J	2.30		2.70	0.091		0.106
K	0.38		0.55	0.015		0.022
L	0	0.10	0.25	0	0.004	0.010
M	1.25		1.35	0.049		0.053

FIG.1: Maximum power dissipation versus RMS on-state current

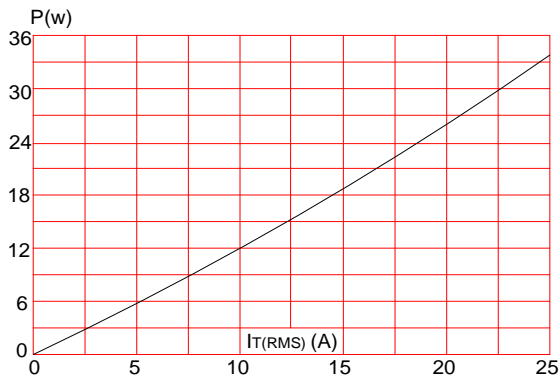

FIG.2: RMS on-state current versus case temperature

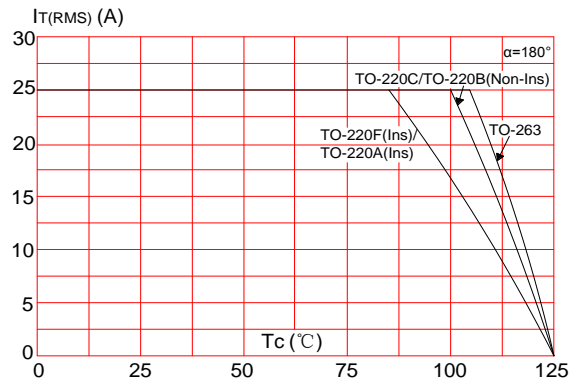

FIG.3: Surge peak on-state current versus number of cycles

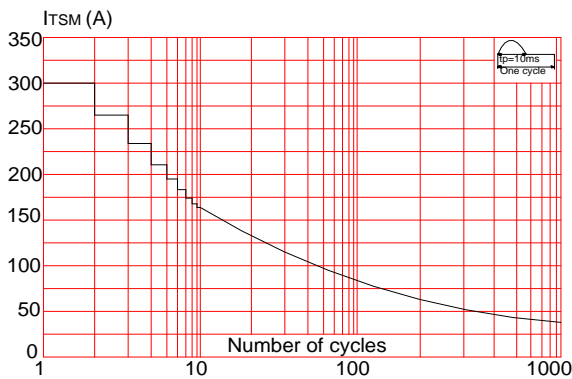

FIG.4: On-state characteristics (maximum values)

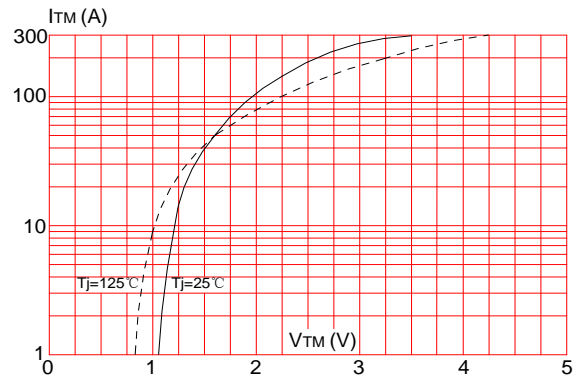

FIG.5: Non-repetitive surge peak on-state current for a sinusoidal pulse with width $t_p < 10\text{ms}$, and corresponding value of I^2t ($di/dt < 150\text{A}/\mu\text{s}$)

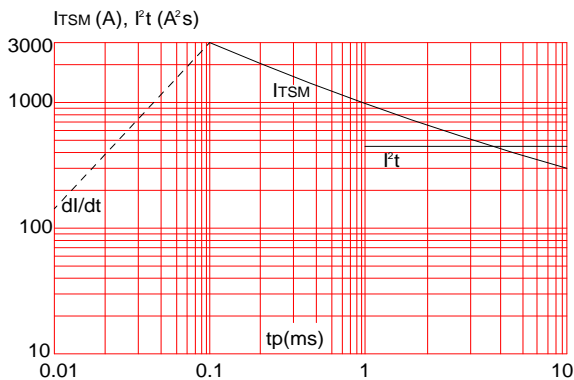
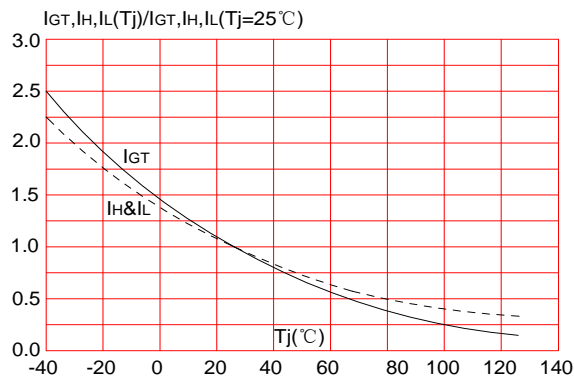



FIG.6: Relative variations of gate trigger current, holding current and latching current versus junction temperature



Information furnished in this document is believed to be accurate and reliable. However, Jiangsu JieJie Microelectronics Co.,Ltd assumes no responsibility for the consequences of use without consideration for such information nor use beyond it. Information mentioned in this document is subject to change without notice, apart from that when an agreement is signed, Jiangsu JieJie complies with the agreement. Products and information provided in this document have no infringement of patents. Jiangsu JieJie assumes no responsibility for any infringement of other rights of third parties which may result from the use of such products and information. This document is the sixth version which is made in 16-May-2016. This document supersedes and replaces all information previously supplied.

 is a registered trademark of Jiangsu JieJie Microelectronics Co.,Ltd.

Copyright ©2016 Jiangsu JieJie Microelectronics Co.,Ltd. Printed All rights reserved.

单击下面可查看定价，库存，交付和生命周期等信息

[>>JW\(捷捷微\)](#)