



Zener Diodes with Surge Current Specification: BZT52C Series

Rev.2.6

FEATURE

- ◇ Silicon power zener diodes.
- ◇ Low zener impedance.
- ◇ 350mW rating on FR-4 or FR-5 board.
- ◇ Voltage range includes breakdown voltages from 2.4V to 43V with $\pm 5\%$ for BZT52C series.
- ◇ Low profile surface-mount package.
- ◇ Zener and surge current specification.
- ◇ For use in stabilizing and clamping circuits with high power rating.

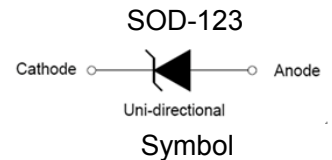
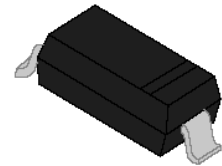

ABSOLUTE MAXIMUM RATINGS AND THERMAL CHARACTERISTICS

Parameter	Symbol	Max Value	Unit
Total power dissipation @ $T_L=75^\circ\text{C}$	P_D	350	mW
Thermal resistance junction to ambient (Note1)	$R_{\theta JA}$	330	$^\circ\text{C/W}$
Junction temperature	T_j	150	$^\circ\text{C}$
Storage temperature range	T_s	-55 to +125	$^\circ\text{C}$

Note1: Device mounted on FR-4 PCB with minimum recommended pad layout

ELECTRICAL CHARACTERISTICS ($T_A=25^\circ\text{C}$)

Symbol	Parameter
V_Z	Reverse zener voltage at I_{zt}
I_{zt}	Reverse current
I_R	Reverse leakage current at V_R
V_R	Reverse voltage
I_F	Forward current
V_F	Forward voltage at I_F

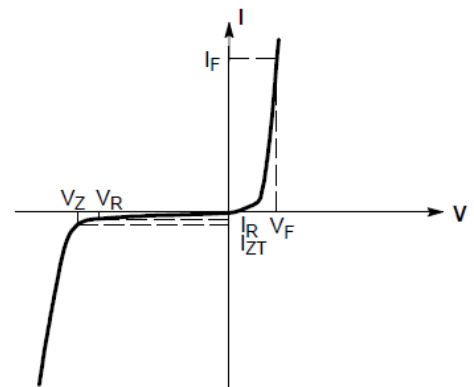

Zener voltage regulator

MARKING



WX: Device Marking Code

BZT52C ELECTRICAL CHARACTERISTICS (T_A=25°C unless otherwise noted)Maximum V_F=0.9V at I_F=10mA

Type number	Zener voltage range at I _{zt}				Maximum zener impedance			Maximum reverse leakage current		Typical temperature coefficient @I _{zTC}		Test current I _{zTC}	Marking
	Nom (V)	Min (V)	Max (V)	I _{zt} (mA)	Z _{zt} (Ω)	Z _{zk} (Ω)	I _{zk} (mA)	I _R (μA)	V _R (V)	Min (mV/°C)	Max (mV/°C)	mA	
BZT52C2V4	2.4	2.2	2.6	5.0	100	600	1.0	50	1.0	-3.5	0	5	WX
BZT52C2V7	2.7	2.5	2.9	5.0	100	600	1.0	20	1.0	-3.5	0	5	W1
BZT52C3V0	3.0	2.8	3.2	5.0	95	600	1.0	10	1.0	-3.5	0	5	W2
BZT52C3V3	3.3	3.1	3.5	5.0	95	600	1.0	5	1.0	-3.5	0	5	W3
BZT52C3V6	3.6	3.4	3.8	5.0	90	600	1.0	5	1.0	-3.5	0	5	W4
BZT52C3V9	3.9	3.7	4.1	5.0	90	600	1.0	3	1.0	-3.5	0	5	W5
BZT52C4V3	4.3	4.0	4.6	5.0	90	600	1.0	3	1.0	-3.5	0	5	W6
BZT52C4V7	4.7	4.4	5.0	5.0	80	500	1.0	3	2.0	-3.5	0.2	5	W7
BZT52C5V1	5.1	4.8	5.4	5.0	60	480	1.0	2	2.0	-2.7	1.2	5	W8
BZT52C5V6	5.6	5.2	6.0	5.0	40	400	1.0	1	2.0	-2.0	2.5	5	W9
BZT52C6V2	6.2	5.8	6.6	5.0	10	150	1.0	3	4.0	0.4	3.7	5	WA
BZT52C6V8	6.8	6.4	7.2	5	15	80	1.0	2	4.0	1.2	4.5	5	WB
BZT52C7V5	7.5	7.0	7.9	5	15	80	1.0	1	5.0	2.5	5.3	5	WC
BZT52C8V2	8.2	7.7	8.7	5	15	80	1.0	0.7	5.0	3.2	6.2	5	WD
BZT52C9V1	9.1	8.5	9.6	5	15	100	1.0	0.5	6.0	3.8	7.0	5	WE
BZT52C10	10	9.4	10.6	5	20	150	1.0	0.2	7.0	4.5	8.0	5	WF
BZT52C11	11	10.4	11.6	5	20	150	1.0	0.1	8.0	5.4	9.0	5	WG
BZT52C12	12	11.4	12.7	5	25	150	1.0	0.1	8.0	6.0	10.0	5	WH
BZT52C13	13	12.4	14.1	5	30	170	1.0	0.1	8.0	7.0	11.0	5	WI
BZT52C15	15	13.8	15.6	5	30	200	1.0	0.1	10.5	9.2	13.0	5	WJ
BZT52C16	16	15.3	17.1	5	40	200	1.0	0.1	11.2	10.4	14.0	5	WK
BZT52C18	18	16.8	19.1	5	45	225	1.0	0.1	12.6	12.4	16.0	5	WL
BZT52C20	20	18.8	21.2	5	55	225	1.0	0.1	14.0	14.4	18.0	5	WM
BZT52C22	22	20.8	23.3	5	55	250	1.0	0.1	15.4	16.4	20.0	5	WN

BZT52C ELECTRICAL CHARACTERISTICS ($T_A=25^{\circ}\text{C}$ unless otherwise noted, continued)
Maximum $V_F=0.9\text{V}$ at $I_F=10\text{mA}$

Type number	Zener voltage range at I_{zt}				Maximum zener impedance			Maximum reverse leakage current		Typical temperature coefficient @ I_{zTC}		Test current I_{zTC}	Marking
	Nom (V)	Min (V)	Max (V)	I_{zt} (mA)	Z_{zt} (Ω)	Z_{zk} (Ω)	I_{zk} (mA)	I_R (μA)	V_R (V)	Min (mV/ $^{\circ}\text{C}$)	Max (mV/ $^{\circ}\text{C}$)	mA	
BZT52C24	24	22.8	25.6	5	70	250	1.0	0.1	16.8	18.4	22.0	5	WO
BZT52C27	27	25.1	28.9	2	80	300	0.5	0.1	18.9	21.4	25.3	2	WP
BZT52C30	30	28.0	32.0	2	80	300	0.5	0.1	21.0	24.4	29.4	2	WQ
BZT52C33	33	31.0	35.0	2	80	325	0.5	0.1	23.1	27.4	33.4	2	WR
BZT52C36	36	34.0	38.0	2	90	350	0.5	0.1	25.2	30.4	37.4	2	WS
BZT52C39	39	37.0	41.0	2	130	350	0.5	0.1	27.3	33.4	41.2	2	WT
BZT52C43	43	40.0	46.0	5	100	700	1.0	0.1	32	10.0	12.0	5	WU

Notes: Zener voltage tolerance of standard BZT52C series is $\pm 5\%$
ORDERING INFORMATION

<div style="display: flex; justify-content: space-around; align-items: center;"> <div style="text-align: center;"> <u>BZT</u> Zener Diode Series </div> <div style="text-align: center;"> <u>52</u> $P_D: 350\text{mW}$ </div> <div style="text-align: center;"> <u>C</u> C: 5% V_z Voltage tolerance </div> <div style="text-align: center;"> <u>2V4</u> Voltage: 2.4V </div> </div>

PACKAGE MECHANICAL DATA

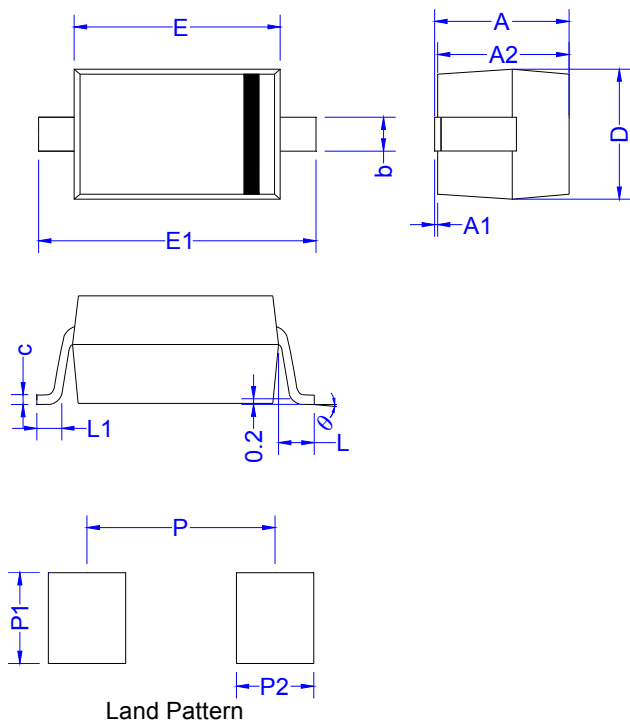

Symbol	Millimeters		Inches	
	Min	Max	Min	Max
A	1.05	1.25	0.041	0.049
A1	0.00	0.10	0.000	0.004
A2	1.05	1.15	0.041	0.045
b	0.45	0.65	0.018	0.026
c	0.08	0.15	0.003	0.006
D	1.50	1.70	0.059	0.067
E	2.60	2.80	0.102	0.110
E1	3.55	3.85	0.140	0.152
L	0.50REF.		0.020 REF.	
L1	0.25	0.45	0.010	0.018
θ	0°	8°	0°	8°
P	3.24		0.128	
P1	1.00		0.039	
P2	0.80		0.031	

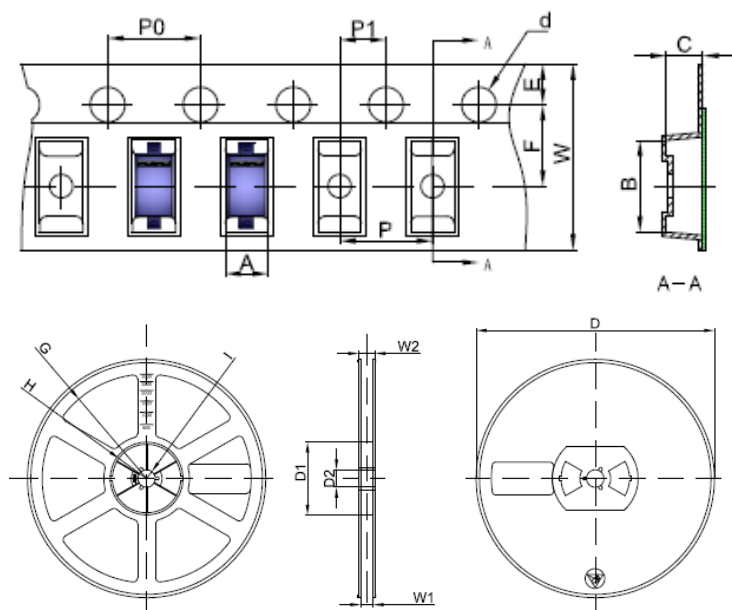
TAPE AND REEL SPECIFICATION-SOD-123

Packaging description:

SOD-123 parts are shipped in tape. The carrier tape is made from a dissipative(carbon filled) polycarbonate resin. The cover tape is a multilayer film(heat activated adhesive in nature)primarily composed of polyester film, adhesive layer, sealant, and anti-static sprayed agent. These reeled parts in standard option are shipped with 3,000 units per 7" or 17.8cm diameter reel. The reels are clear in color and made of polystyrene plastic(anti-static coated).

Symbol	Millimeters	Inches
	Typ.	Typ.
A	1.85	0.073
B	3.95	0.156
C	1.57	0.062
d	Φ1.55	Φ 0.061
E	1.75	0.069
F	3.50	0.138
P0	4.0	0.157
P	4.0	0.157
P1	2.0	0.079
W	8.00	0.315
D	Φ178.0	Φ7.008
D1	54.40	2.142
D2	13.0	0.512
G	R78.0	R3.071
H	R25.60	R1.008
I	R6.50	R0.256
W1	9.50	0.374
W2	12.30	0.484

ORDERING INFORMATION

OUTLINE	PACKAGE	REEL SIZE	QUANTITY PER REEL
TAPING	SOD-123	7 Inch	3,000PCS

RATINGS AND CHARACTERISTICS CURVES ($T_A=25^{\circ}\text{C}$, unless otherwise noted)

Fig.1 Power dissipation vs lead temperature

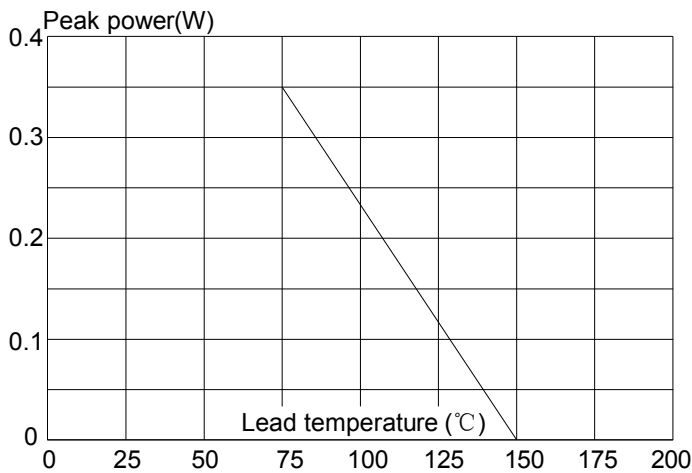

Fig.2 Zener breakdown characteristics

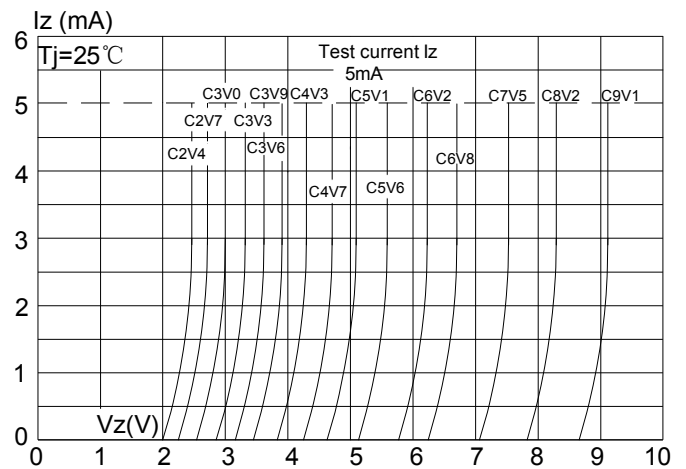
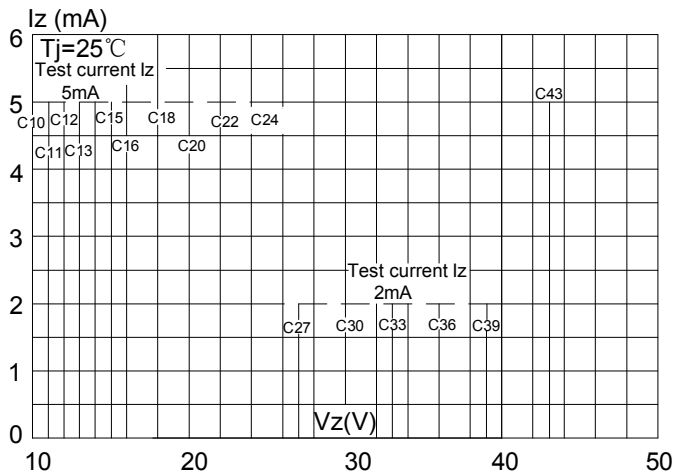

Fig.3 Zener breakdown characteristics



Information furnished in this document is believed to be accurate and reliable. However, Jiangsu JieJie Microelectronics Co.,Ltd assumes no responsibility for the consequences of use without consideration for such information nor use beyond it.

Information mentioned in this document is subject to change without notice, apart from that when an agreement is signed, Jiangsu JieJie complies with the agreement.

Products and information provided in this document have no infringement of patents. Jiangsu JieJie assumes no responsibility for any infringement of other rights of third parties which may result from the use of such products and information.

This document is the 2.6th version which is made in 23-July-2021. This document supersedes and replaces all information previously supplied.

 is a registered trademark of Jiangsu JieJie Microelectronics Co.,Ltd.

Copyright ©2021 Jiangsu JieJie Microelectronics Co.,Ltd. Printed All rights reserved.

单击下面可查看定价，库存，交付和生命周期等信息

[>>JW\(捷捷微\)](#)