



MMBT5551 Small Signal NPN Transistor

Rev.1.3

FEATURE:

- Complementary to MMBT5401.
- Power dissipation of 300mW.
- High stability and high reliability.

MECHANICAL DATA:

- SOT-23 small outline plastic package
- Epoxy UL: 94V-0
- Mounting position: Any
- Marking:G1

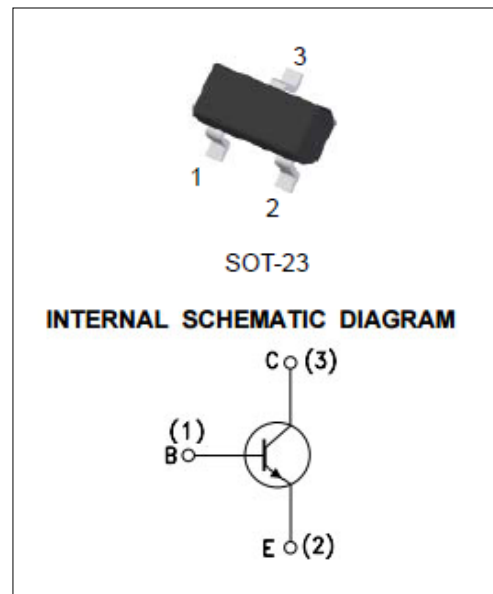

ABSOLUTE MAXIMUM RATINGS ($T_A=25^{\circ}\text{C}$, unless otherwise specified.)

Parameter	Symbol	Value	Unit
Storage temperature range	T_{stg}	-55 to 150	$^{\circ}\text{C}$
Max. operating junction temperature	T_j	150	$^{\circ}\text{C}$
Collector-emitter voltage ($I_B=0$)	V_{CEO}	160	V
Collector-base voltage ($I_E=0$)	V_{CBO}	180	V
Emitter-base voltage ($I_C=0$)	V_{EBO}	6	V
Collector current DC	I_C	600	mA
Collector power dissipation	P_C	300	mW

ELECTRICAL CHARACTERISTICS ($T_A=25^{\circ}\text{C}$, unless otherwise specified)

Symbol	Test Condition	Value			Unit
		MIN.	TYP.	MAX.	
$V_{(BR)CBO}$	$I_C=100\mu\text{A}$, $I_E=0$	180	-	-	V
$V_{(BR)CEO}$	$I_C=1\text{mA}$, $I_B=0$	160	-	-	V
$V_{(BR)EBO}$	$I_E=10\mu\text{A}$, $I_C=0$	6	-	-	V
I_{CBO}	$V_{CB}=120\text{V}$, $I_E=0$	-	-	50	nA
I_{EBO}	$V_{EB}=4\text{V}$, $I_C=0$	-	-	50	nA
h_{FE}^*	$I_C=1\text{mA}$, $V_{CE}=5\text{V}$	80	-	-	
	$I_C=10\text{mA}$, $V_{CE}=5\text{V}$	100	300	-	
	$I_C=50\text{mA}$, $V_{CE}=5\text{V}$	30	-	-	
$V_{CE(sat)}^*$	$I_C=10\text{mA}$, $I_B=1\text{mA}$	-	-	0.15	V
	$I_C=50\text{mA}$, $I_B=5\text{mA}$	-	-	0.20	
$V_{BE(sat)}^*$	$I_C=10\text{mA}$, $I_B=1\text{mA}$	-	-	1.0	V
	$I_C=50\text{mA}$, $I_B=5\text{mA}$	-	-	1.0	
I_{CES}	$V_{CB}=10\text{V}$	-	-	50	nA
	$V_{CB}=75\text{V}$	-	-	100	
f_T	$V_{CE}=10\text{V}$, $I_C=10\text{mA}$, $f=100\text{MHz}$	100	-	300	MHz

* Pulsed: pulse duration = 300 μs , duty cycle $\leq 2\%$

THERMAL RESISTANCES

Symbol	Parameter	Value (Max.)	Unit
$R_{th(J-A)}$	junction to ambient	416	$^{\circ}\text{C}/\text{W}$

PACKAGE MECHANICAL DATA

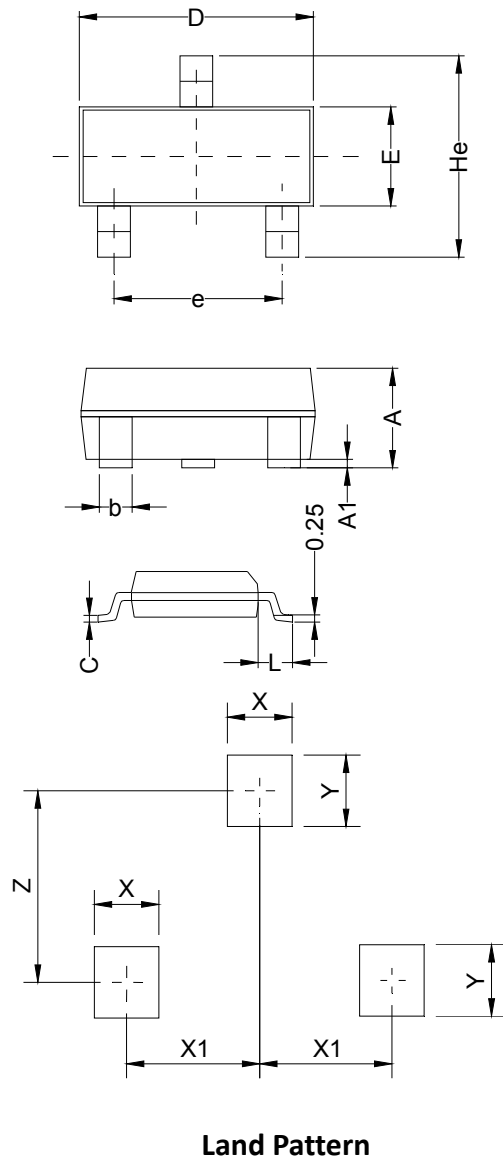

Symbol	Millimeters			Inches		
	Min.	Typ.	Max.	Min.	Typ.	Max.
A	0.90	1.063	1.15	0.035	0.042	0.045
A1	0.00	0.075	0.14	0.000	0.003	0.006
b	0.30	0.40	0.50	0.012	0.016	0.020
C	0.07	0.10	0.15	0.003	0.004	0.006
D	2.80	2.90	3.00	0.110	0.114	0.118
e	1.80	1.90	2.00	0.071	0.075	0.079
E	1.20	1.30	1.40	0.047	0.051	0.055
L	0.55REF			0.022REF		
He	2.25	2.40	2.55	0.089	0.094	0.100
X	0.80			0.031		
X1	0.95			0.037		
Y	0.80			0.031		
Z	2.02			0.080		

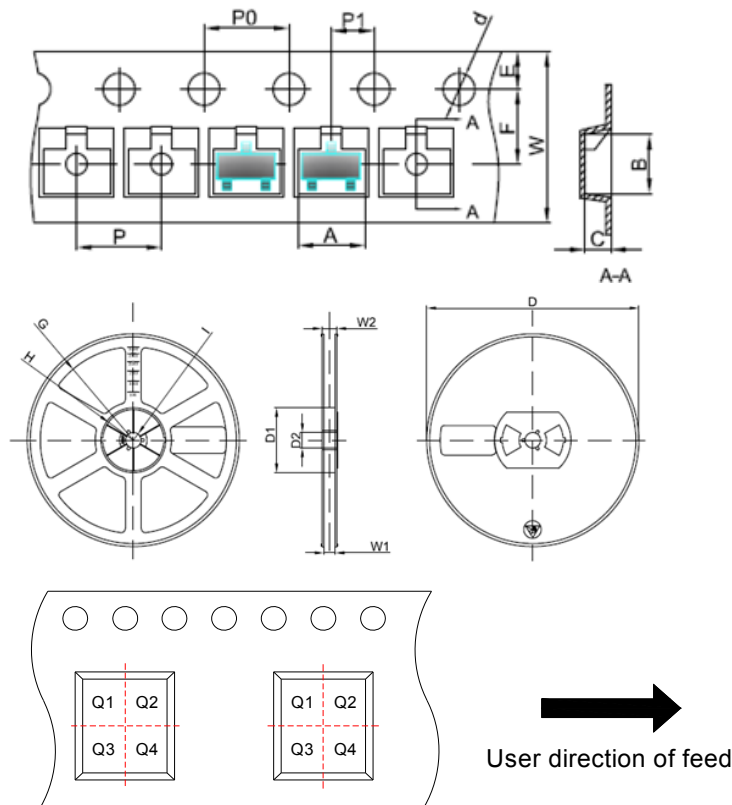
TAPE AND REEL SPECIFICATION-SOT-23

Pin 1 quadrant: Q3

Packaging Description:

SOT-23 parts are shipped in tape. The carrier tape is made from a dissipative(carbon filled) polycarbonate resin. The cover tape is a multilayer film(heat activated adhesive in nature)primarily composed of polyester film, adhesive layer, sealant, and anti-static sprayed agent. These reeled parts in standard option are shipped with 3,000units per 7" or 17.8cm diameter reel. The reels are clear in color and made of polystyrene plastic(anti-static coated).

Symbol	Millimeters	Inches
	Typ.	Typ.
A	3.15	0.124
B	2.77	0.109
C	1.22	0.048
d	Φ1.50	Φ0.059
E	1.75	0.069
F	3.50	0.138
P0	4.00	0.157
P	4.00	0.157
P1	2.00	0.079
W	8.00	0.315
D	Φ178	Φ7.008
D1	54.40	2.142
D2	13.00	0.512
G	R78.00	R3.071
H	R25.60	R1.008
I	R6.50	R0.256
W1	9.50	0.374
W2	12.30	0.484

ORDERING INFORMATION

Part Number	Package	Reel Size	Quantity Per Reel
MMBT5551	SOT-23	7 Inch	3,000 pcs

FIG.1: Static characteristic

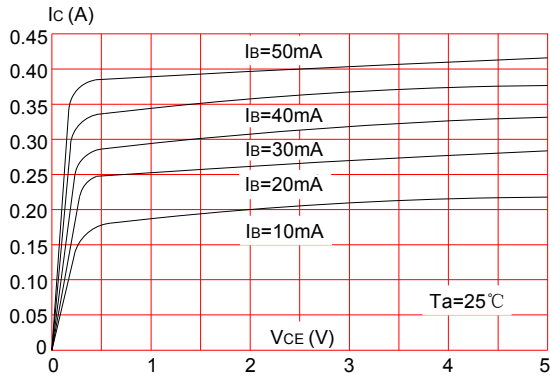

FIG.3: Base current vs. collector emitter saturation voltage

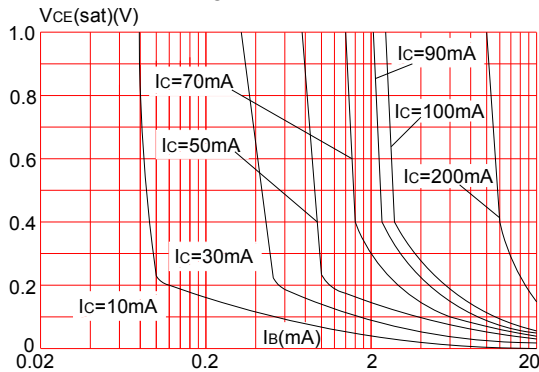

FIG.5: Collector current vs. base emitter saturation voltage

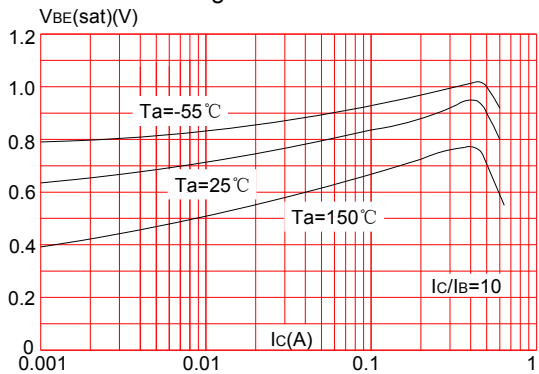

FIG.7: Collector current vs. collector emitter saturation voltage (Ic/Ib=10)

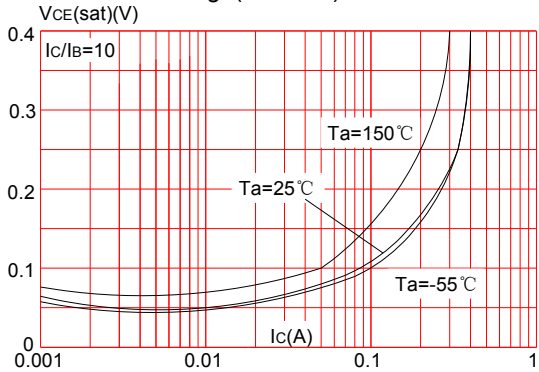

FIG.2: Collector current vs. DC current gain

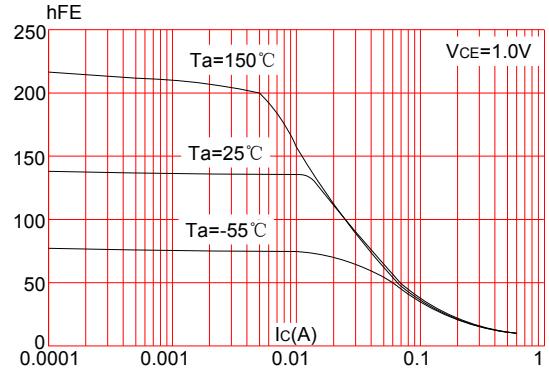

FIG.4: Collector current vs. base emitter voltage (on)

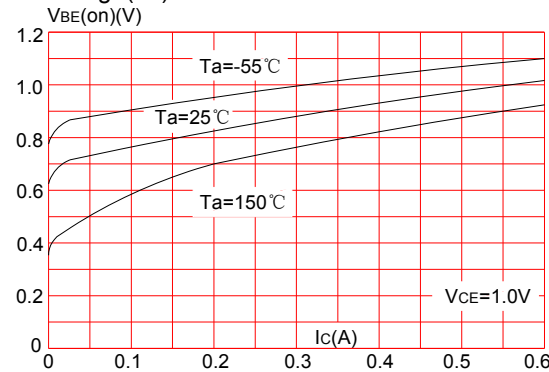

FIG.6: Collector current vs. collector emitter saturation voltage (Ic/Ib=5)

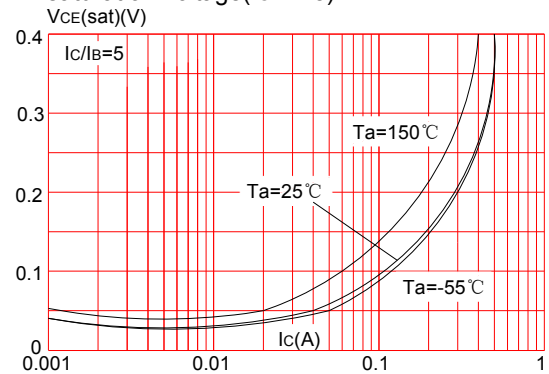

FIG.8: Capacitance characteristic

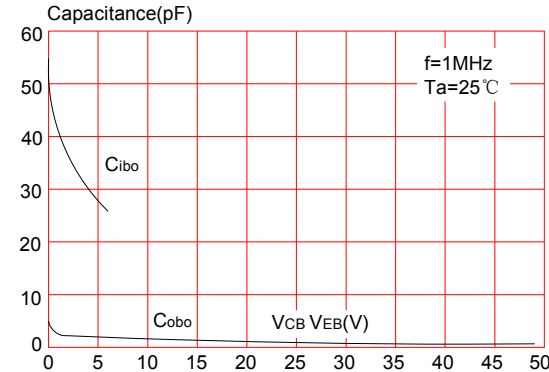
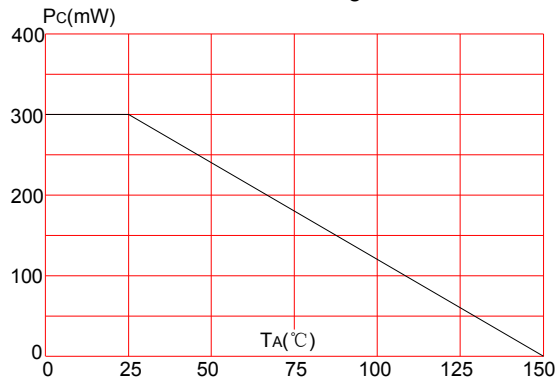

FIG.9: Power derating curve



Information furnished in this document is believed to be accurate and reliable. However, Jiangsu JieJie Microelectronics Co.,Ltd assumes no responsibility for the consequences of use without consideration for such information nor use beyond it. Information mentioned in this document is subject to change without notice, apart from that when an agreement is signed, Jiangsu JieJie complies with the agreement. Products and information provided in this document have no infringement of patents. Jiangsu JieJie assumes no responsibility for any infringement of other rights of third parties which may result from the use of such products and information. This document is the 1.3rd version which is made in 19-June-2021. This document supersedes and replaces all information previously supplied.



is a registered trademark of Jiangsu JieJie Microelectronics Co.,Ltd.

Copyright ©2021 Jiangsu JieJie Microelectronics Co.,Ltd. Printed All rights reserved.

单击下面可查看定价，库存，交付和生命周期等信息

[>>JW\(捷捷微\)](#)