



# -60V 40mΩ P-Ch Power MOSFET

### Features

- Low Gate Charge
- 100% UIS Tested, 100% R<sub>g</sub> Tested
- Pb-free Lead Plating
- Halogen-free and RoHS-compliant

### Product Summary

Parameter	Value	Unit
V <sub>DS</sub>	-60	V
V <sub>GS(th)_Typ</sub>	-2.0	V
I <sub>D</sub> (@ V <sub>GS</sub> = -10V) <sup>(1)</sup>	-22	A
R <sub>DS(ON)_Typ</sub> (@ V <sub>GS</sub> = -10V)	40	mΩ
R <sub>DS(ON)_Typ</sub> (@ V <sub>GS</sub> = -4.5V)	55	mΩ

### Applications

- LED Back-lighting Application
- DC/DC Power Management
- High Side Switch for Full Bridge Converter

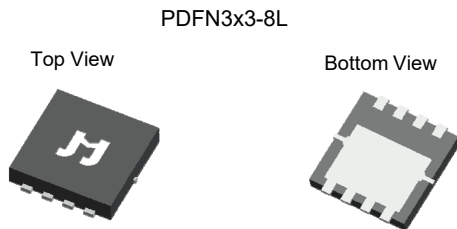

Pin Configuration  
Top View

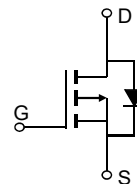
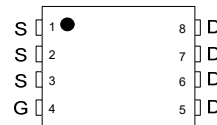

### Ordering Information

Device	Package	# of Pins	Marking	MSL	T <sub>J</sub> (°C)	Media	Quantity (pcs)
JMPL0648AU-13	PDFN3x3-8L	8	PL0648A	1	-55 to 150	13-inch Reel	5000

### Absolute Maximum Ratings (@ T<sub>A</sub> = 25°C unless otherwise specified)

Parameter	Symbol	Value	Unit
Drain-to-Source Voltage	V <sub>DS</sub>	-60	V
Gate-to-Source Voltage	V <sub>GS</sub>	±20	V
Continuous Drain Current <sup>(1)</sup>	I <sub>D</sub>	T <sub>C</sub> = 25°C	-22
		T <sub>C</sub> = 100°C	-14.2
Pulsed Drain Current <sup>(2)</sup>	I <sub>DM</sub>	-70	A
Avalanche Energy <sup>(3)</sup>	E <sub>AS</sub>	75	mJ
Power Dissipation <sup>(4)</sup>	P <sub>D</sub>	T <sub>C</sub> = 25°C	41
		T <sub>C</sub> = 100°C	16.6
Junction & Storage Temperature Range	T <sub>J</sub> , T <sub>STG</sub>	-55 to 150	°C

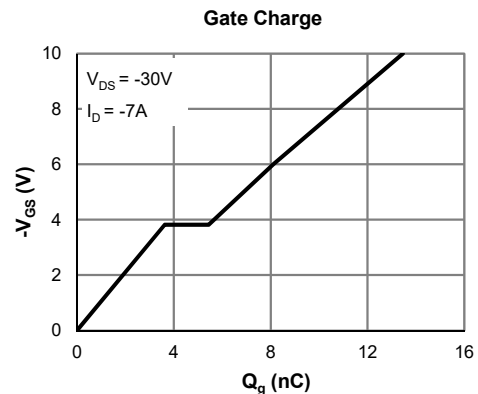
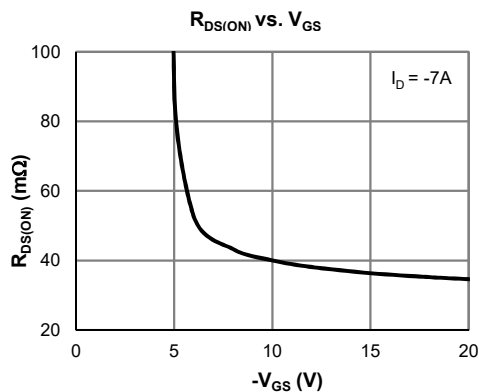



**Electrical Characteristics** (@ T<sub>J</sub> = 25°C unless otherwise specified)

Parameter	Symbol	Conditions	Min.	Typ.	Max.	Unit
<b>STATIC PARAMETERS</b>						
Drain-Source Breakdown Voltage	V <sub>(BR)DSS</sub>	I <sub>D</sub> = -250μA, V <sub>GS</sub> = 0V	-60			V
Zero Gate Voltage Drain Current	I <sub>DSS</sub>	V <sub>DS</sub> = -48V, V <sub>GS</sub> = 0V T <sub>J</sub> = 55°C			-1.0 -5.0	μA
Gate-Body Leakage Current	I <sub>GSS</sub>	V <sub>DS</sub> = 0V, V <sub>GS</sub> = ±20V			±100	nA
Gate Threshold Voltage	V <sub>GS(th)</sub>	V <sub>DS</sub> = V <sub>GS</sub> , I <sub>D</sub> = -250μA	-1.0	-2.0	-3.0	V
Static Drain-Source ON-Resistance	R <sub>DS(on)</sub>	V <sub>GS</sub> = -10V, I <sub>D</sub> = -7A		40	50	mΩ
		V <sub>GS</sub> = -4.5V, I <sub>D</sub> = -5A		55	72	mΩ
Forward Transconductance	g <sub>FS</sub>	V <sub>DS</sub> = -5V, I <sub>D</sub> = -7A		20		S
Diode Forward Voltage	V <sub>SD</sub>	I <sub>S</sub> = -1A, V <sub>GS</sub> = 0V		-0.77	-1.0	V
Diode Continuous Current	I <sub>S</sub>	T <sub>C</sub> = 25°C			-22	A
<b>DYNAMIC PARAMETERS</b> <sup>(5)</sup>						
Input Capacitance	C <sub>iss</sub>	V <sub>GS</sub> = 0V, V <sub>DS</sub> = -30V, f = 1MHz		855		pF
Output Capacitance	C <sub>oss</sub>			189		pF
Reverse Transfer Capacitance	C <sub>rss</sub>			9.5		pF
Gate Resistance	R <sub>g</sub>	V <sub>GS</sub> = 0V, V <sub>DS</sub> = 0V, f = 1MHz		9.0		Ω
<b>SWITCHING PARAMETERS</b> <sup>(5)</sup>						
Total Gate Charge (@ V <sub>GS</sub> = -10V)	Q <sub>g</sub>	V <sub>GS</sub> = 0 to -10V V <sub>DS</sub> = -30V, I <sub>D</sub> = -7A		13.5		nC
Total Gate Charge (@ V <sub>GS</sub> = -4.5V)	Q <sub>g</sub>			6.4		nC
Gate Source Charge	Q <sub>gs</sub>			3.6		nC
Gate Drain Charge	Q <sub>gd</sub>			1.8		nC
Turn-On Delay Time	t <sub>D(on)</sub>	V <sub>GS</sub> = -10V, V <sub>DS</sub> = -30V R <sub>L</sub> = 4.3Ω, R <sub>GEN</sub> = 3Ω		5.4		ns
Turn-On Rise Time	t <sub>r</sub>			1.9		ns
Turn-Off Delay Time	t <sub>D(off)</sub>			23		ns
Turn-Off Fall Time	t <sub>f</sub>			4.2		ns
Body Diode Reverse Recovery Time	t <sub>rr</sub>		I <sub>F</sub> = -7A, dI <sub>F</sub> /dt = -100A/μs		27	
Body Diode Reverse Recovery Charge	Q <sub>rr</sub>	I <sub>F</sub> = -7A, dI <sub>F</sub> /dt = -100A/μs		28		nC

**Thermal Performance**

Parameter	Symbol	Typ.	Max.	Unit
Thermal Resistance, Junction-to-Ambient	R <sub>θJA</sub>	65	75	°C/W
Thermal Resistance, Junction-to-Case	R <sub>θJC</sub>	3.0	4.0	°C/W

**Notes:**

1. Computed continuous current assumes the condition of T<sub>J,Max</sub> while the actual continuous current depends on the thermal & electro-mechanical application board design.
2. This single-pulse measurement was taken under T<sub>J,Max</sub> = 150°C.
3. E<sub>AS</sub> of 75 mJ is based on starting T<sub>J</sub> = 25°C, L = 3.0mH, I<sub>AS</sub> = -7.1A, V<sub>GS</sub> = -10V, V<sub>DD</sub> = -30V; 100% test at L = 0.1mH, I<sub>AS</sub> = -25A. T<sub>J,Max</sub> = 150°C.
4. The power dissipation P<sub>D</sub> is based on T<sub>J,Max</sub> = 150°C.
5. This value is guaranteed by design hence it is not included in the production test.

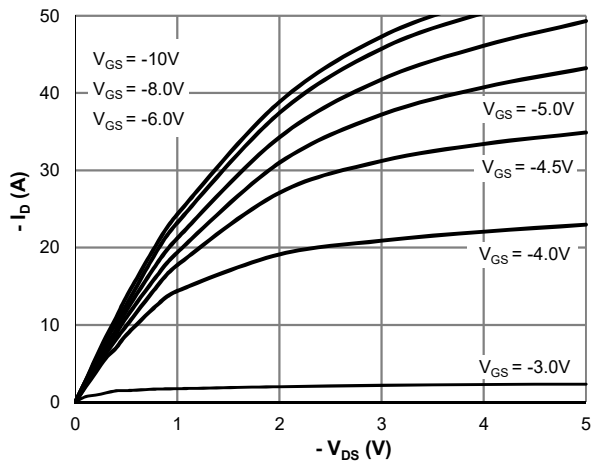
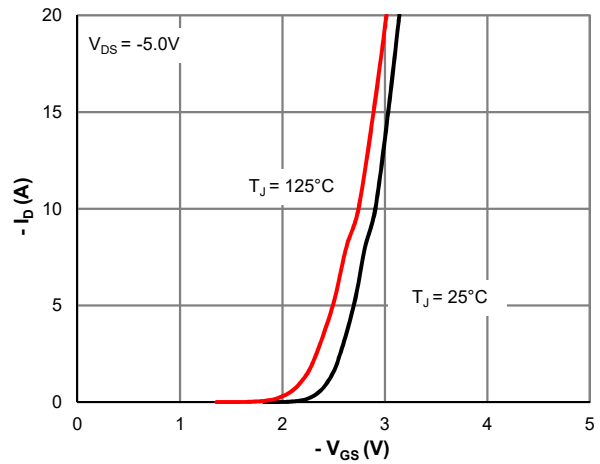
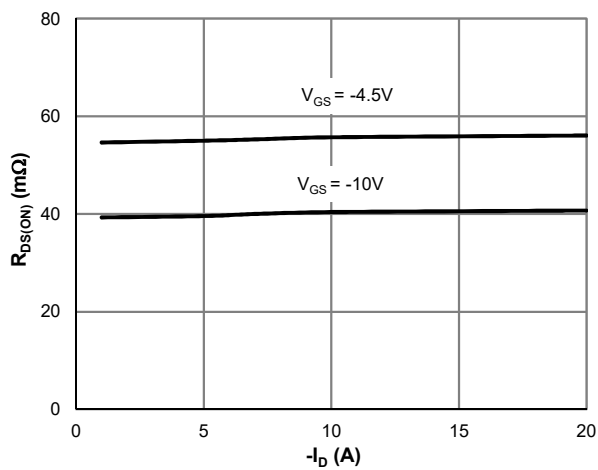
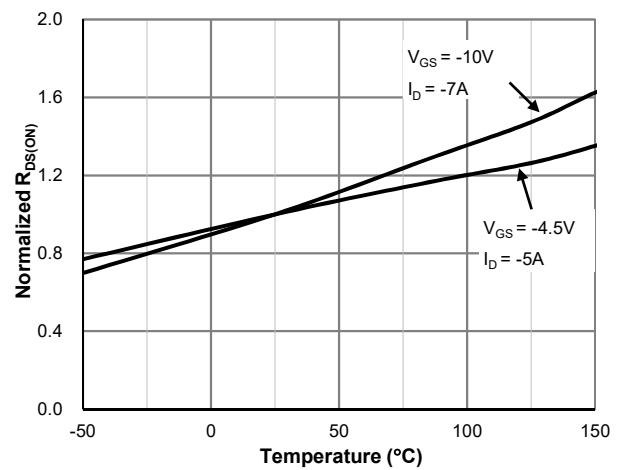
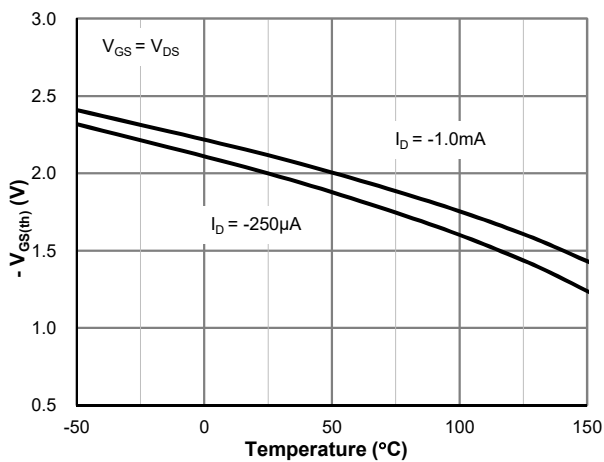
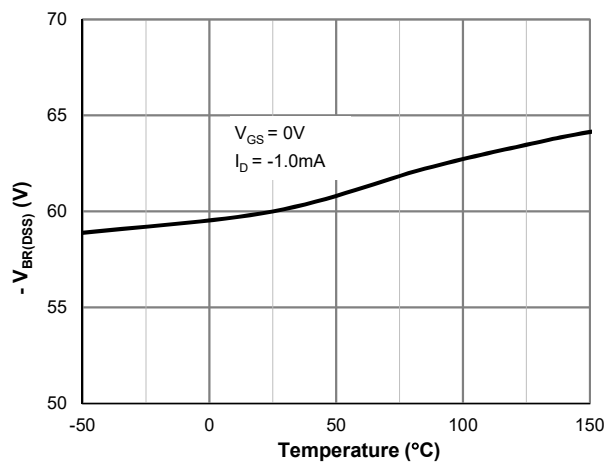
**Typical Electrical & Thermal Characteristics**

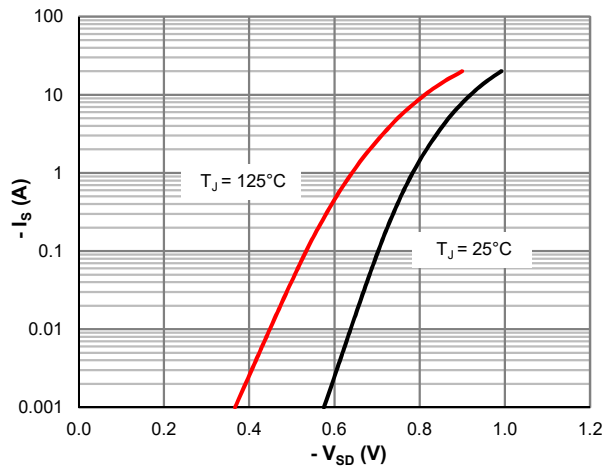
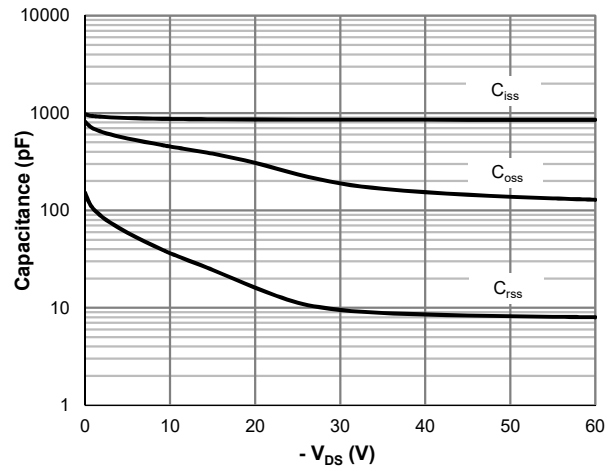
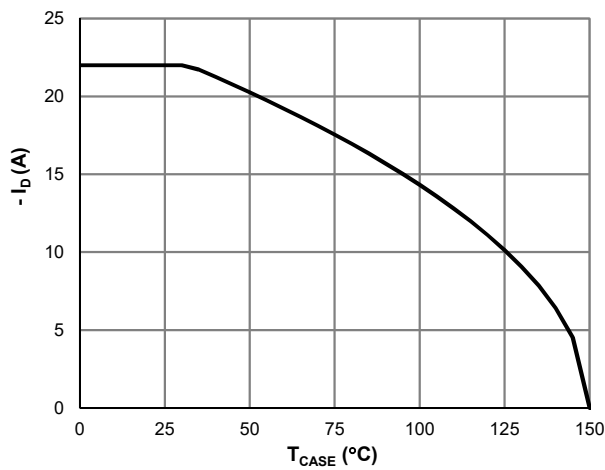
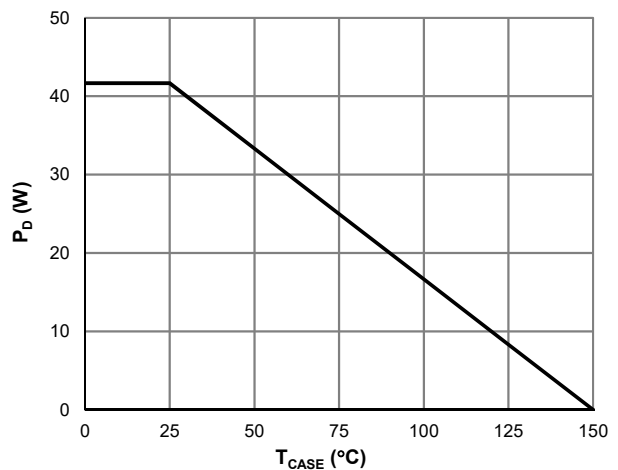
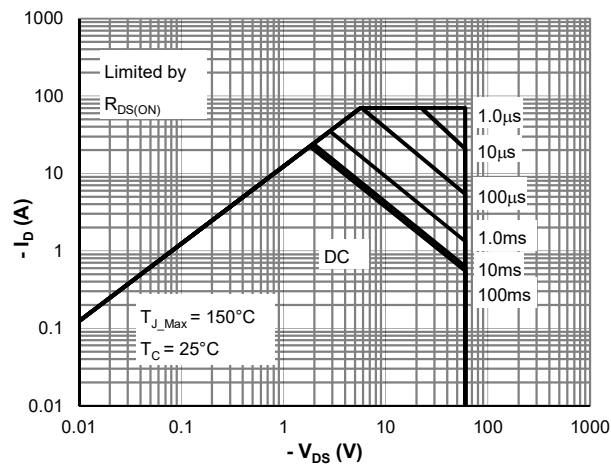
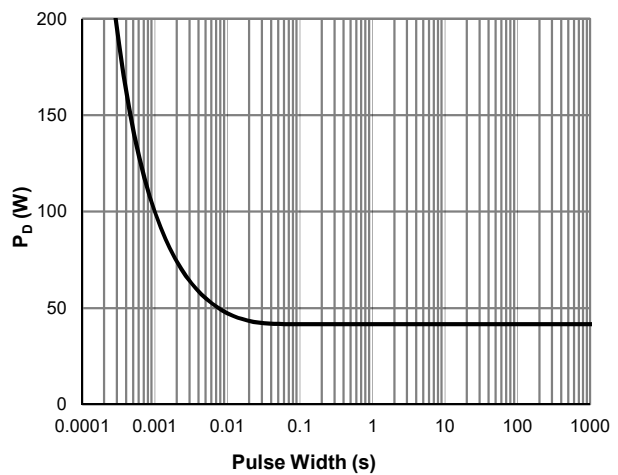
**Figure 1: Saturation Characteristics**

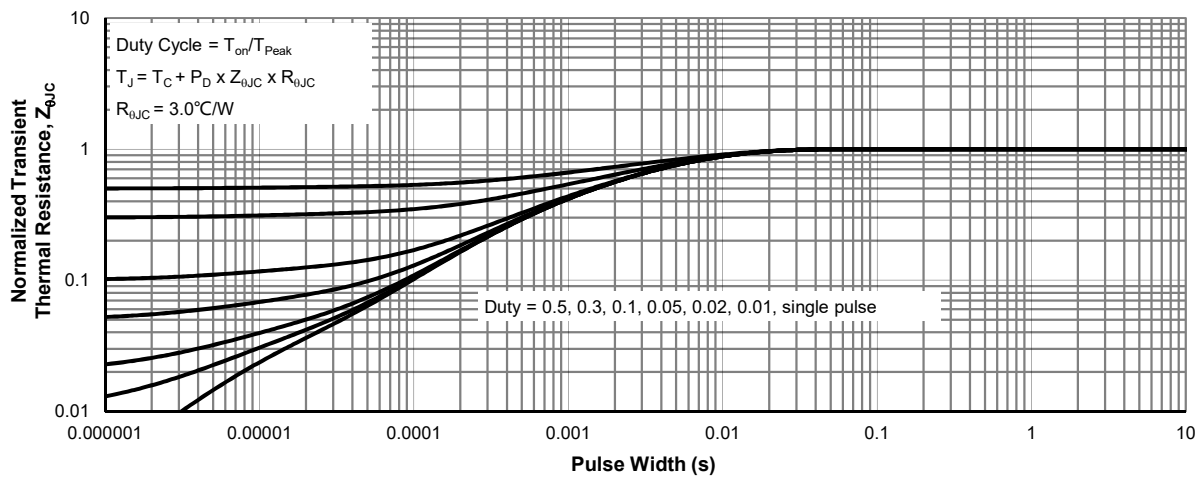
**Figure 2: Transfer Characteristics**

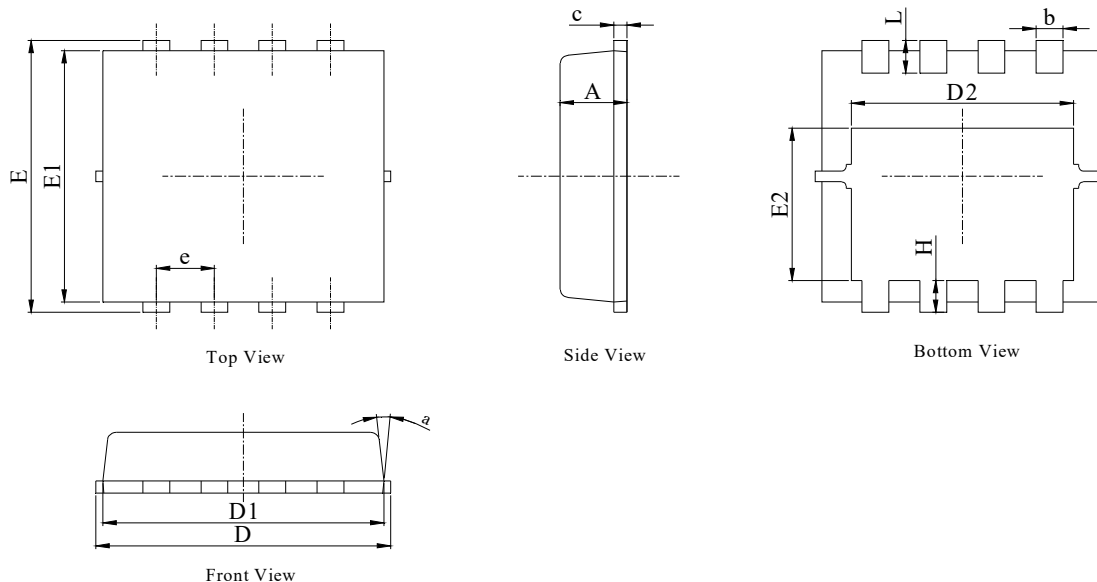
**Figure 3:  $R_{DS(ON)}$  vs. Drain Current**

**Figure 4:  $R_{DS(ON)}$  vs. Junction Temperature**

**Figure 5:  $V_{GS(th)}$  vs. Junction Temperature**

**Figure 6:  $V_{BR(DSS)}$  vs. Junction Temperature**

**Typical Electrical & Thermal Characteristics**

**Figure 7: Body-Diode Characteristics**

**Figure 8: Capacitance Characteristics**

**Figure 9: Current De-rating**

**Figure 10: Power De-rating**

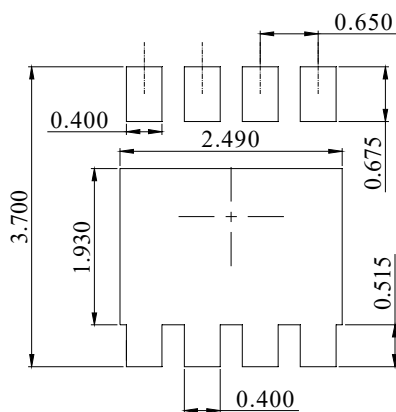
**Figure 11: Maximum Safe Operating Area**

**Figure 12: Single Pulse Power Rating, Junction-to-Case**

**Typical Electrical & Thermal Characteristics**

**Figure 13: Normalized Maximum Transient Thermal Impedance**

**PDFN3x3-8L Package Information**
**Package Outline**

**NOTES:**

1. DIMENSIONING AND TOLERANCING PER ASME Y14.5M,1994.
2. ALL DIMNESIONS IN MILLIMETER (ANNGLE IN DEGREE).
3. DIMENSIONS D1 AND E1 DO NOT INCLUDE MOLD FLASH PROTRUSIONS OR GATE BURRS.

DIM.	MILLIMETER		
	MIN.	NOM.	MAX.
A	0.70	0.75	0.80
b	0.25	0.30	0.35
c	0.10	0.20	0.25
D	3.00	3.15	3.25
D1	2.95	3.05	3.15
D2	2.39	2.49	2.59
E	3.20	3.30	3.40
E1	2.95	3.05	3.15
E2	1.70	1.80	1.90
e	0.65 BSC		
H	0.30	0.40	0.50
L	0.25	0.40	0.50
a	---	---	15°

**Recommended Soldering Footprint**

DIMENSIONS:MILLIMETERS

单击下面可查看定价，库存，交付和生命周期等信息

[>>JW\(捷捷微\)](#)