

## 80V 3.6mΩ N-Ch Power MOSFET

### Features

- Ultra Low  $R_{DS(ON)}$
- Low Gate Charge
- High Current Capability
- 100% UIS Tested, 100%  $R_g$  Tested

### Applications

- Power Management in Telecom., Industrial Automation, CE
- Motor Driving in Power Tool, E-vehicle, Robotics
- Current Switching in DC/DC & AC/DC (SR) Sub-systems

### Product Summary

Items	Typ.	Units
$V_{DS}$	80	V
$V_{GS(th)}$	2.8	V
$I_D$ (at $V_{GS}=10V$ )	101	A
$R_{DS(ON)}$ (at $V_{GS}=10V$ )	3.6	mΩ

TO251 Top View

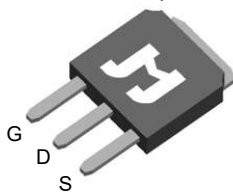

TO252-3L Top View

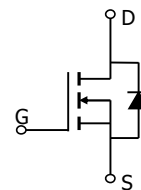
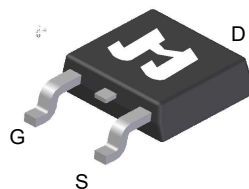

### Ordering information

Device	Package	Pins	Marking	MSL	$T_J$ (°C)	Reel Size	Quantity
JMSH0804AH-U	TO251-3L	3	SH0804A	N/A	-55 to 150	Tube	80
JMSH0804AK-13	TO252-3L	3	SH0804A	MSL3	-55 to 150	13 inch	2500

### Absolute Maximum Ratings $T_A=25^\circ\text{C}$ (unless otherwise specified)

Parameter	Symbol	Value	Units
Drain to source voltage	$V_{DS}$	80	V
Gate to source voltage	$V_{GS}$	$\pm 20$	V
Continuous Drain Current	$I_D$	$T_C=25^\circ\text{C}$	101
		$T_C=70^\circ\text{C}$	81
Pulsed Drain Current	$I_{DM}$	400	A
Avalanche Current	$I_{AS}$	60	A
Avalanche energy $L=0.1\text{mH}$	$E_{AS}$	180	mJ
Power Dissipation	$P_D$	$T_C=25^\circ\text{C}$	78
		$T_C=70^\circ\text{C}$	50
Junction and Storage Temp. Range	$T_J, T_{STG}$	-55 to 150	°C

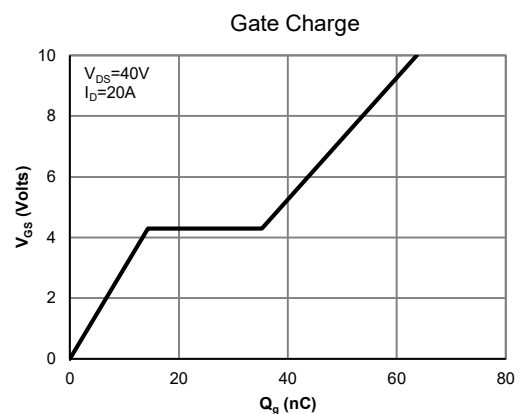
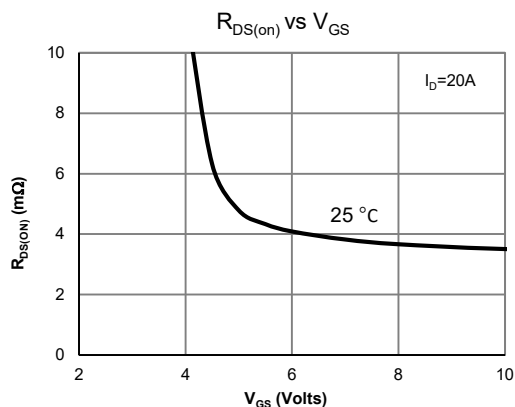



**Electrical Characteristics (T<sub>J</sub>=25° C unless otherwise specified)**

Parameter	Symbol	Conditions	Min.	Typ.	Max.	Units
<b>STATIC PARAMETERS</b>						
Drain-Source Breakdown Voltage	V <sub>(BR)DSS</sub>	I <sub>D</sub> =250μA, V <sub>GS</sub> =0V	80			V
Zero Gate Voltage Drain Current	I <sub>DSS</sub>	V <sub>DS</sub> =64V, V <sub>GS</sub> =0V T <sub>J</sub> =55°C			1 5	μA
Gate-Body leakage current	I <sub>GSS</sub>	V <sub>DS</sub> =0V, V <sub>GS</sub> = ±20V			±100	nA
Gate Threshold Voltage	V <sub>GS(th)</sub>	V <sub>DS</sub> =V <sub>GS</sub> I <sub>D</sub> =250μA	2	2.8	4	V
Static Drain-Source On-Resistance	R <sub>DS(ON)</sub>	V <sub>GS</sub> =10V, I <sub>D</sub> =20A		3.6	4.2	mΩ
Forward Transconductance	g <sub>FS</sub>	V <sub>DS</sub> =5V, I <sub>D</sub> =20A		75		S
Diode Forward Voltage	V <sub>SD</sub>	I <sub>S</sub> =1A, V <sub>GS</sub> =0V		0.7	1	V
Maximum Diode Continuous Current	I <sub>S</sub>	T <sub>C</sub> =25° C			78	A

<b>DYNAMIC PARAMETERS</b>						
Input Capacitance	C <sub>iss</sub>	V <sub>GS</sub> =0V, V <sub>DS</sub> =40V, f=1MHz		3783		pF
Output Capacitance	C <sub>oss</sub>			1373		pF
Reverse Transfer Capacitance	C <sub>rss</sub>			22		pF
Gate resistance	R <sub>g</sub>	V <sub>GS</sub> =0V, V <sub>DS</sub> =0V, f=1MHz		1.2		Ω

<b>SWITCHING PARAMETERS</b>						
Total Gate Charge	Q <sub>g(10V)</sub>	V <sub>GS</sub> =10V, V <sub>DS</sub> =40V, I <sub>D</sub> =20A		63		nC
Total Gate Charge	Q <sub>g(6V)</sub>			43		nC
Gate Source Charge	Q <sub>gs</sub>			14		nC
Gate Drain Charge	Q <sub>gd</sub>			21		nC
Turn-On DelayTime	t <sub>D(on)</sub>	V <sub>GS</sub> =10V, V <sub>DS</sub> =40V, R <sub>L</sub> =2Ω, R <sub>GEN</sub> =6Ω		14		ns
Turn-On Rise Time	t <sub>r</sub>			22		ns
Turn-Off DelayTime	t <sub>D(off)</sub>			65		ns
Turn-Off Fall Time	t <sub>f</sub>			37		ns
Body Diode Reverse Recovery Time	t <sub>rr</sub>		I <sub>F</sub> =20A, dI/dt=100A/μs		65	
Body Diode Reverse Recovery Charge	Q <sub>rr</sub>	I <sub>F</sub> =20A, dI/dt=100A/μs		147		nC

**Thermal performance**

Parameter	Symbol	Typ	Max	Units
Maximum Junction-to-Ambient	R <sub>θJA</sub>	45	55	° C/W
Maximum Junction-to-Case	R <sub>θJC</sub>	1.3	1.6	° C/W

TYPICAL ELECTRICAL AND THERMAL CHARACTERISTICS

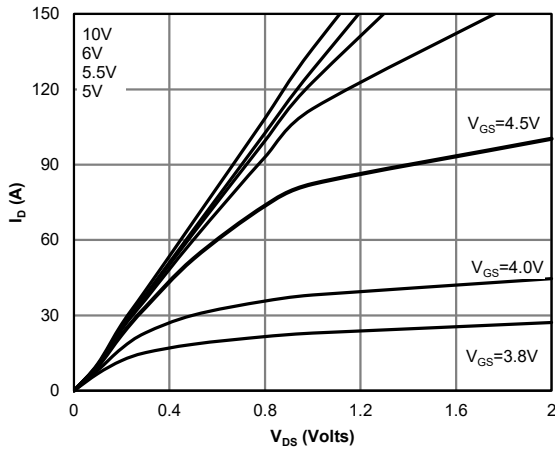

Fig 1: Saturation Characteristics

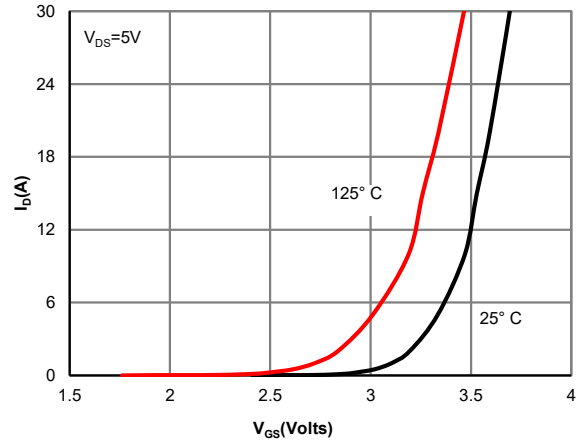

Figure 2: Transfer Characteristics

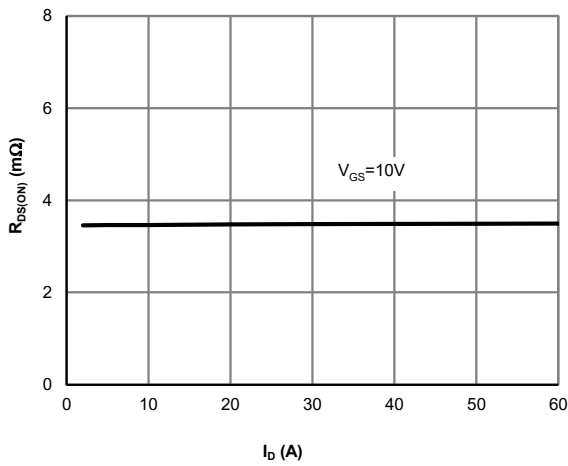

Figure 3:  $R_{DS(ON)}$  vs. Drain Current

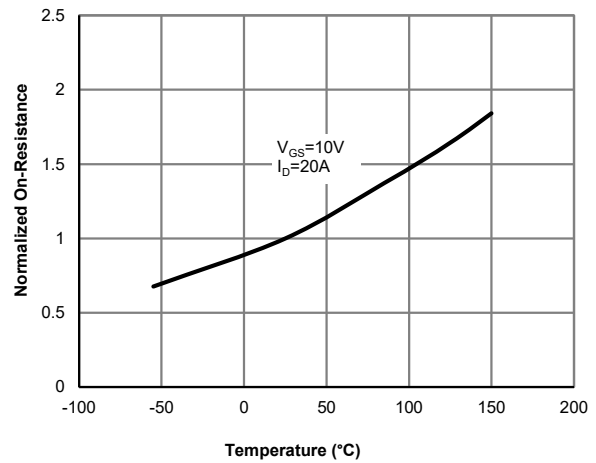

Figure 4:  $R_{DS(ON)}$  vs. Junction Temperature

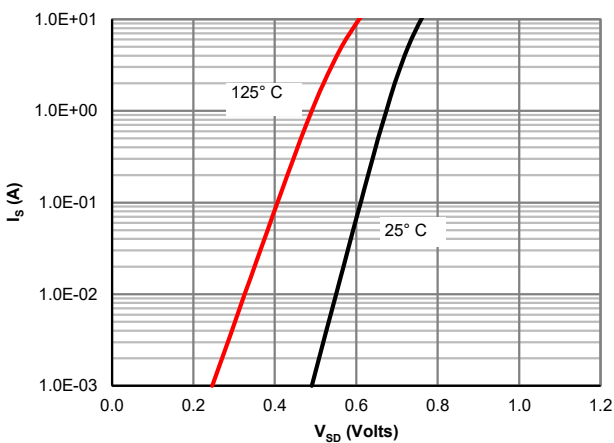

Figure 5: Body-Diode Characteristics

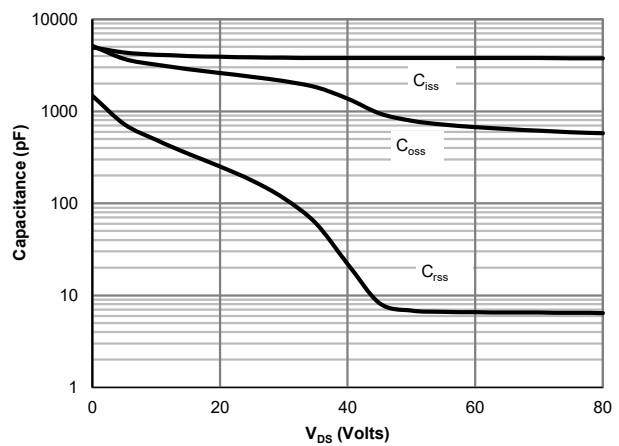

Figure 6: Capacitance Characteristics

TYPICAL ELECTRICAL AND THERMAL CHARACTERISTICS

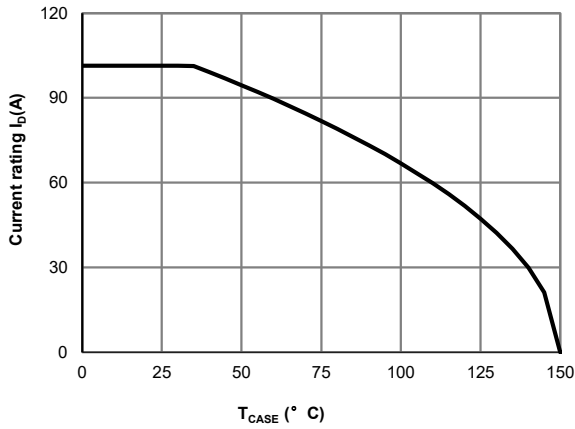

Figure 7: Current De-rating

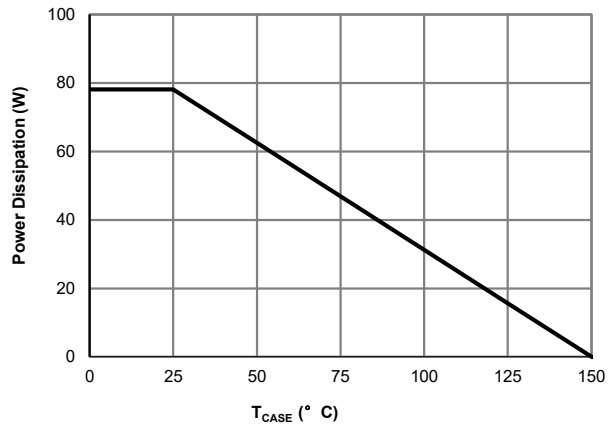

Figure 8: Power De-rating

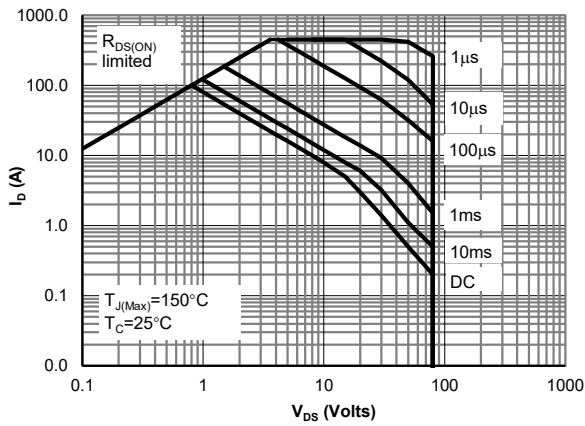

Figure 9: Maximum Safe Operating Area

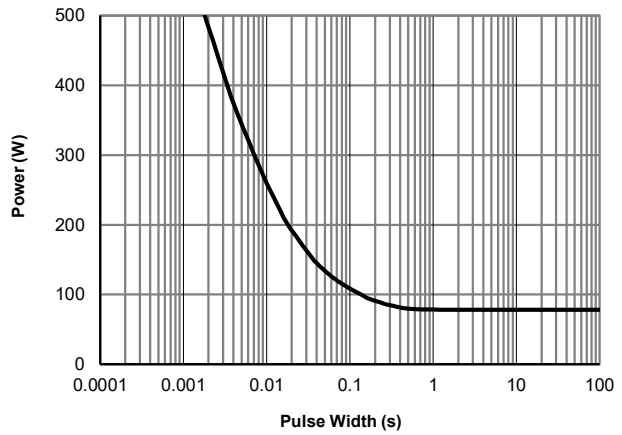

Figure 10: Single Pulse Power Rating Junction-to-Case

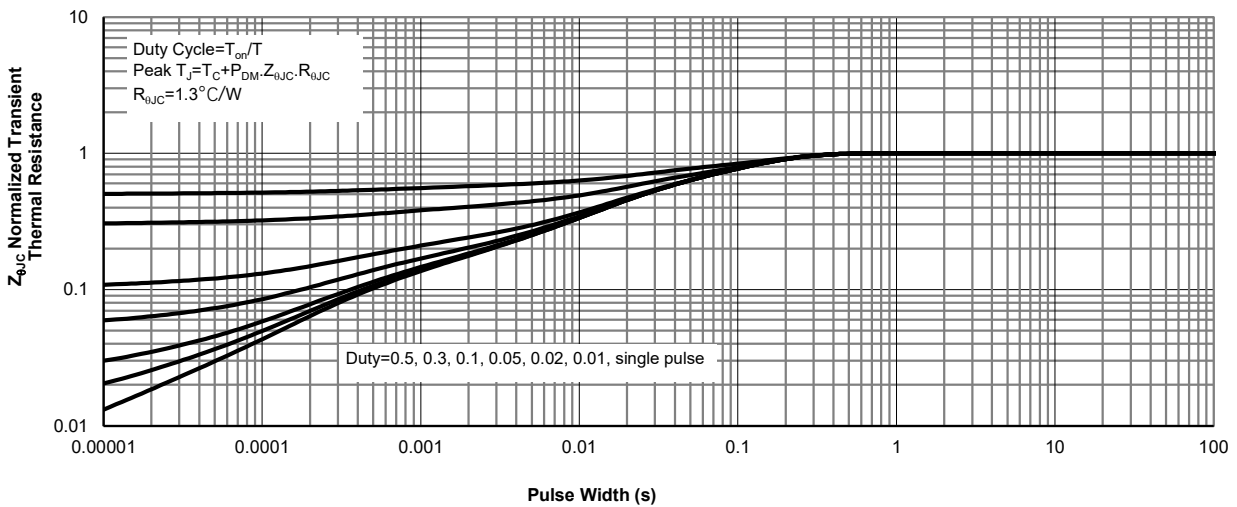
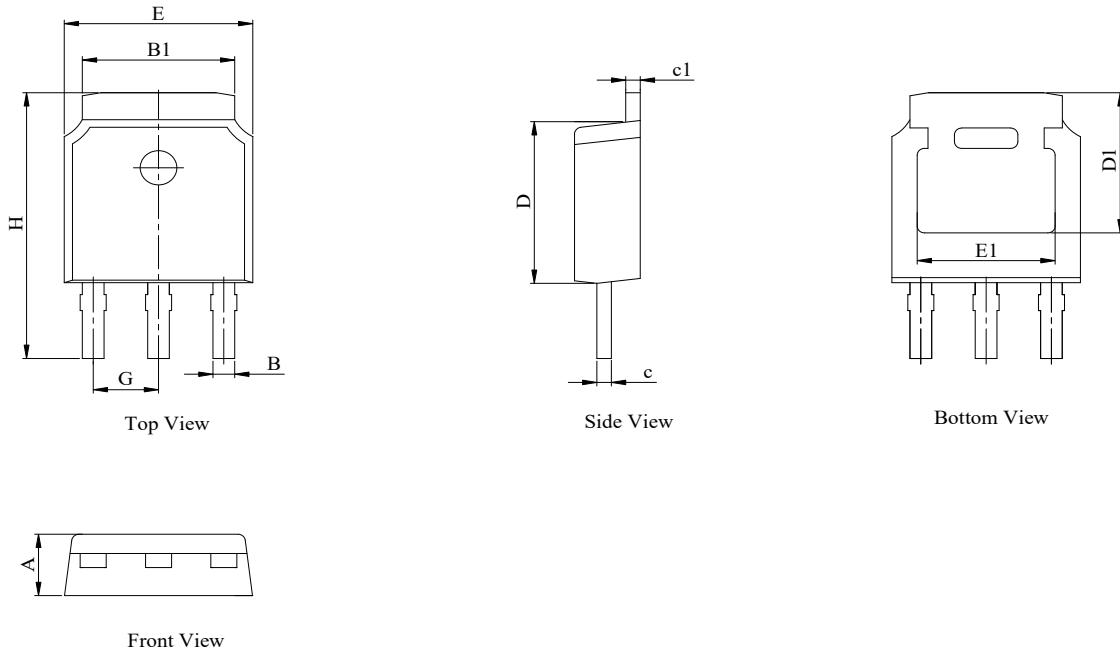

Figure 11: Normalized Maximum Transient Thermal Impedance (Note F)

**TO251-3L Package Information** (All units in mm)

**Package Outline**



DIM.	MILLIMETER		
	MIN.	NOM.	MAX.
A	2.10		2.50
B	0.66		0.86
B1	5.15		5.48
c	0.44		0.58
c1	0.44		0.58
D	5.90		6.30
D1	5.30 REF		
E	6.40		6.80
E1	4.83 REF		
G	2.19	2.29	2.39
H	10.60		11.80

**TO252-3L Package Information** (All units in mm)

**Package Outline**

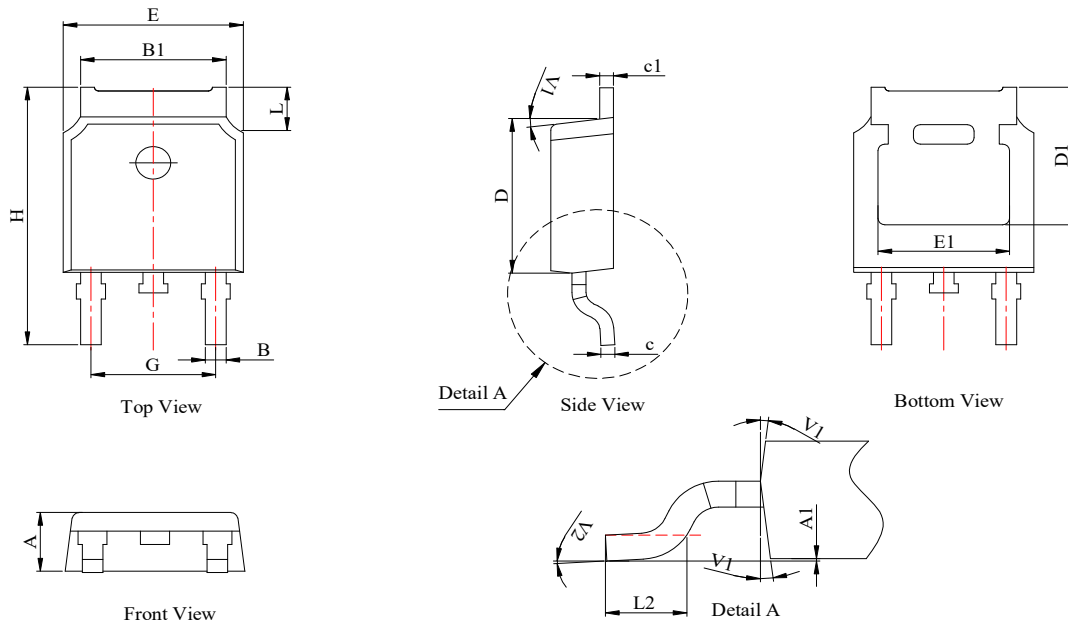

DIM.	MILLIMETER		
	MIN.	NOM.	MAX.
A	2.10		2.50
A1	0	-	0.10
B	0.66		0.86
B1	5.18		5.48
c	0.40		0.60
c1	0.44		0.58
D	5.90		6.30
D1	5.30REF		
E	6.40		6.80
E1	4.63		
G	4.47		4.67
H	9.50		10.70
L	1.09		1.21
L2	1.35		1.65
V1		7°	
V2	0°	-	6°

**Recommend Soldering Footprint**

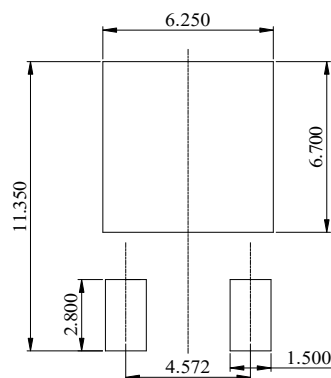

DIMENSIONS: MILLIMETERS

单击下面可查看定价，库存，交付和生命周期等信息

[>>JW\(捷捷微\)](#)