

Performance Specification

Model	V _{max} (V dc)	I _{max} (A)	I _{hold} @25°C (A)	I _{trip} @25°C (A)	P _d Typ. (W)	Maximum Time To Trip		Resistance	
						Current (A)	Time (Sec)	R _{i min} (Ω)	R _{1max} (Ω)
JSMD0603-005	24.0	40	0.05	0.20	0.5	0.5	1.00	2.000	10.000
JSMD0603-010	15.0	40	0.10	0.30	0.5	0.5	1.00	0.900	6.000
JSMD0603-020	9.0	40	0.20	0.50	0.5	1.0	0.60	0.550	3.500
JSMD0603-035	6.0	40	0.35	0.75	0.5	8.0	0.10	0.200	1.400
JSMD0603-050	6.0	40	0.50	1.00	0.5	8.0	0.10	0.100	0.800

V_{max} = Maximum operating voltage device can withstand without damage at rated current (I_{max}).

I_{max} = Maximum fault current device can withstand without damage at rated voltage (V_{max}).

I_{hold} = Hold Current. Maximum current device will not trip in 25°C still air.

I_{trip} = Trip Current. Minimum current at which the device will always trip in 25°C still air.

P_d = Power dissipation when device is in the tripped state in 25°C still air environment at rated voltage.

R_{i min}/max = Minimum/Maximum device resistance prior to tripping at 25°C.

R_{1max} = Maximum device resistance is measured one hour post reflow.

CAUTION : Operation beyond the specified ratings may result in damage and possible arcing and flame.

Environmental Specifications

Test	Conditions	Resistance change
Passive aging	+85°C, 1000 hrs.	±5% typical
Humidity aging	+85°C, 85% R.H. , 168 hours	±5% typical
Thermal shock	+85°C to -40°C, 20 times	±33% typical
Resistance to solvent	MIL-STD-202,Method 215	No change
Vibration	MIL-STD-202,Method 201	No change
Ambient operating conditions : - 40 °C to +85 °C		
Maximum surface temperature of the device in the tripped state is 125 °C		

Agency Approval and Environmental Compliance

Agency	File Number	Regulation	Standard
UL	E486890		2011/65/EU
TUV	pending		EN14582

Thermal Derating Chart

Recommended Hold Current(A) at Ambient Temperature(°C)

Model	Ambient Operation Temperature								
	-40°C	-20°C	0°C	25°C	40°C	50°C	60°C	70°C	85°C
JSMD0603-005	0.072	0.065	0.058	0.050	0.041	0.037	0.033	0.030	0.024
JSMD0603-010	0.13	0.12	0.11	0.10	0.08	0.07	0.06	0.05	0.03
JSMD0603-020	0.27	0.25	0.23	0.20	0.17	0.14	0.12	0.10	0.07
JSMD0603-035	0.47	0.41	0.38	0.35	0.29	0.26	0.24	0.20	0.14
JSMD0603-050	0.67	0.59	0.54	0.50	0.41	0.37	0.34	0.29	0.20

Thermal Derating Curve

Average Time-Current Curve

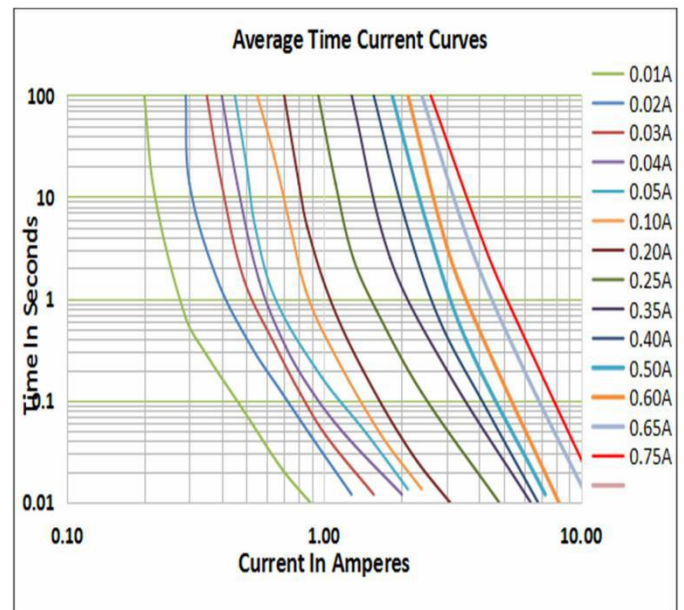
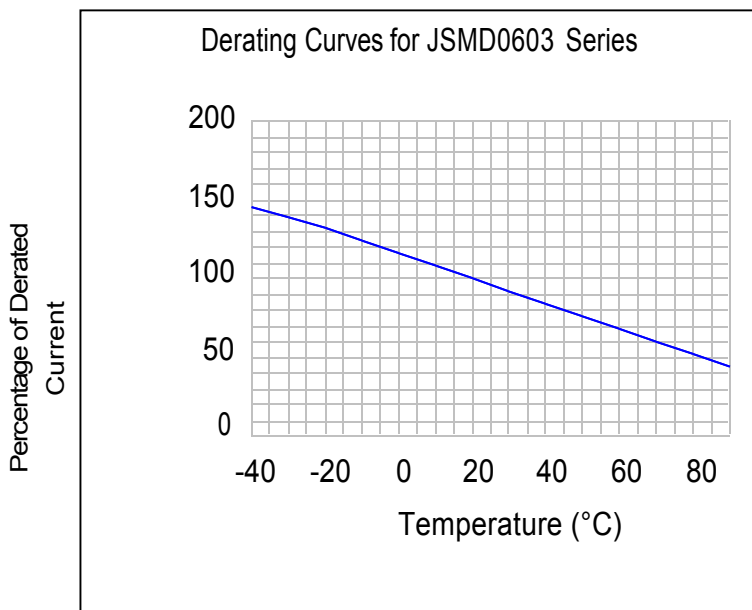

Soldering Parameters

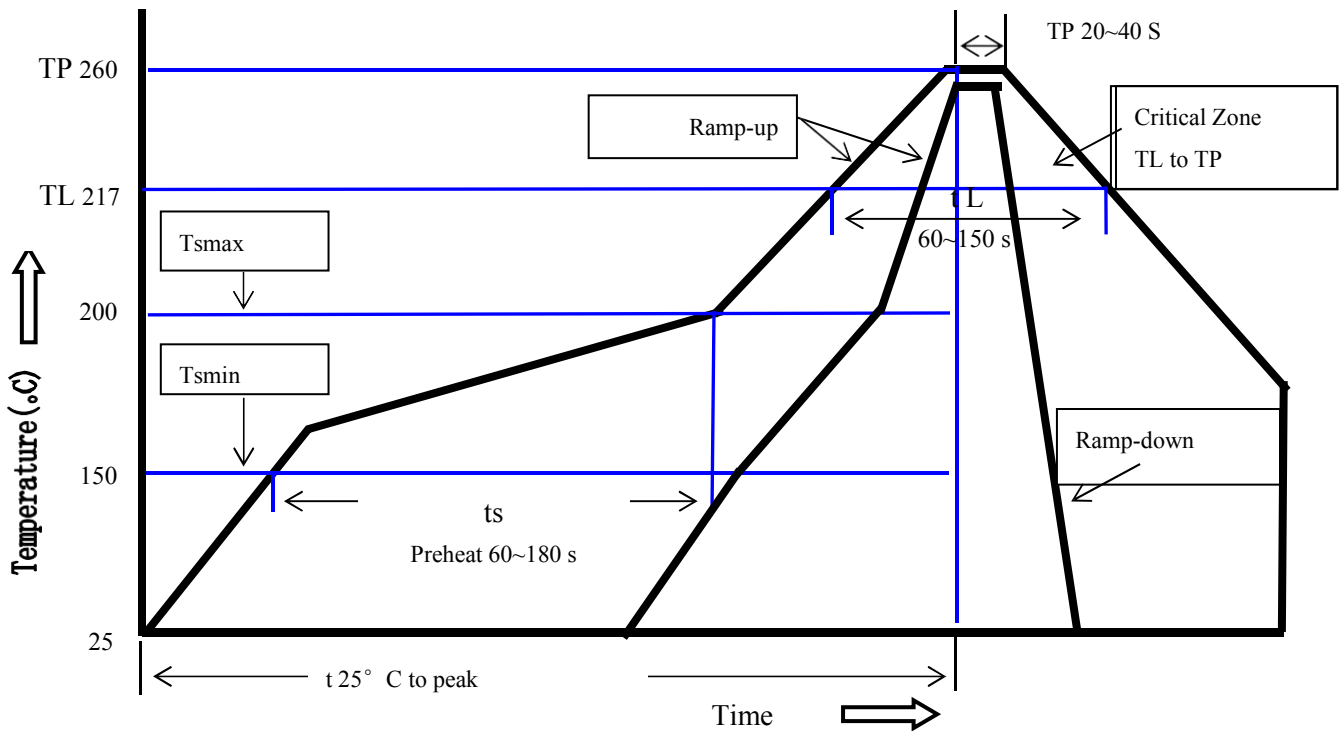

Profile Feature	Pb-Free Assembly
Average Ramp-Up Rate(Ts max to T p)	3°C/second max.
Preheat	
-Temperature Min(Ts min)	150°C
-Temperature Max(Ts max)	200°C
-Time(Ts min to Ts max)	60~180 seconds
Time maintained above:	
-Temperature(TL)	217°C
-Time(tL)	60~150 seconds
Peak Temperature(Tp)	260°C
Ramp-Down Rate	6°C/second max.
Time 25°C to Peak Temperature	8 minutes max
Storage Condition	0°C~35°C, ≤70%RH

Recommended reflow methods: IR, vapor phase oven, hot air oven, N2 environment for lead-free

Recommended maximum paste thickness is 0.25mm

Devices can be cleaned using standard industry methods and solvents.

Note 1: All temperature refer to topside of the package, measured on the package body surface.

Note 2: If reflow temperatures exceed the recommended profile, devices may not meet the performance requirements.

Physical Dimensions(mm.)

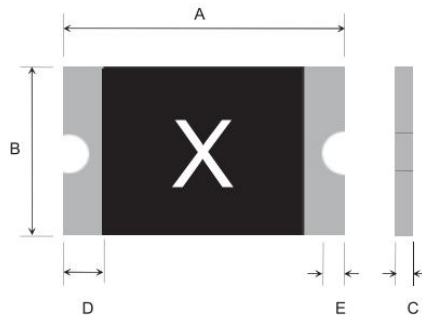

Model	A		B		C		D	E
	Min.	Max.	Min.	Max.	Min.	Max.	Min.	Min.
JSMD0603-005	1.45	1.85	0.65	1.05	0.40	1.00	0.15	0.1
JSMD0603-010	1.45	1.85	0.65	1.05	0.40	1.00	0.15	0.1
JSMD0603-020	1.45	1.85	0.65	1.05	0.40	1.00	0.15	0.1
JSMD0603-035	1.45	1.85	0.65	1.05	0.40	1.00	0.15	0.1
JSMD0603-050	1.45	1.85	0.65	1.05	0.40	1.10	0.15	0.1

Termination Pad Characteristics

Terminal pad materials: Tin-plated Nickel-Copper

Terminal pad solder ability: Meets EIA specification RS186-9E and ANSI/J-STD-002 Category 3.

Recommended Pad Layout (mm.)

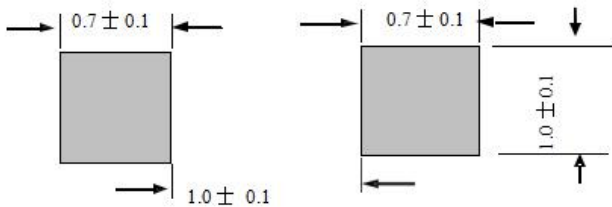

Packaging Quantity

Part Number	Quantity
JSMD 050	4,000 pcs/reel
The others	5,000 pcs/reel

Tape & reel packaging per EIA481-1

Tape And Reel Specifications (mm)

Governing Specifications	EIA 481-1
W	8.0 ± 0.2
P0	4.0 ± 0.10
P1	4.0 ± 0.10
P2	2.0 ± 0.05
A0	1.05 ± 0.10
B0	1.85 ± 0.10
D0	1.55 ± 0.10
F	3.5 ± 0.05
E1	1.75 ± 0.10
E2min.	6.25
T	0.75
T1max.	0.1
K0	0.74/0.95 ± 0.1
Leader min.	390
Trailer min.	160
Reel Dimensions	
A max.	178
N min.	60
W1	9.0 ± 0.5
W2	12.0 ± 0.05

EIA Tape Component Dimensions

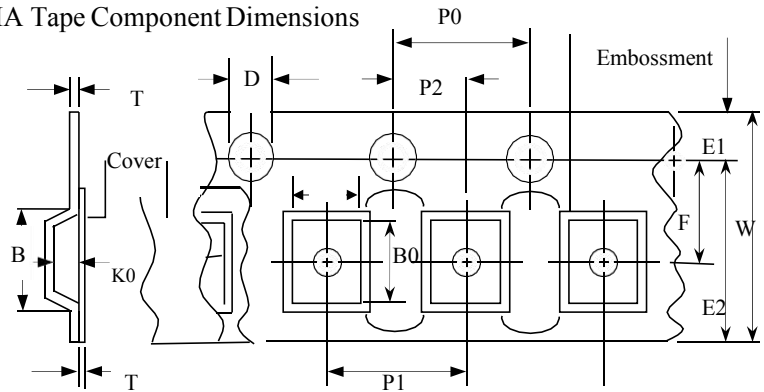

EIA Reel Dimensions

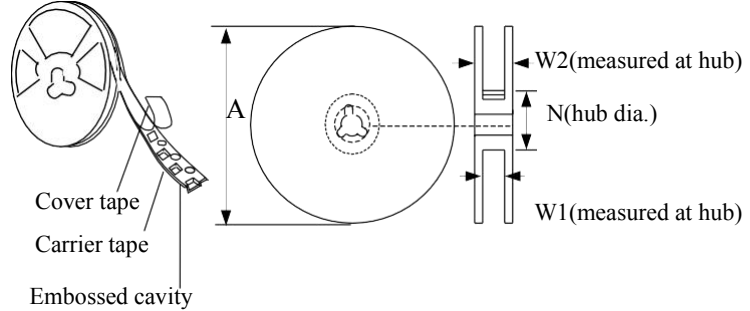

Storage And Handling

- Storage conditions: 35°C max, 70% R.H.
- Devices may not meet specified performance if storage conditions are exceeded.

Part Number System

J SMD0603- □□□ / □□

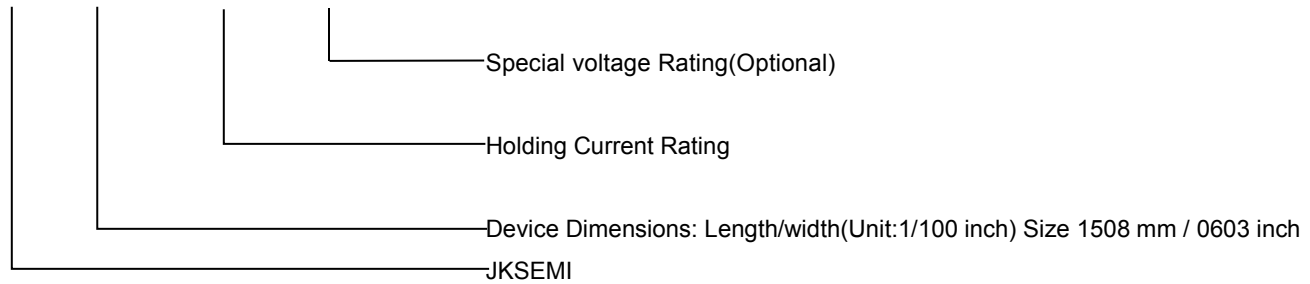

Cross Reference

JKSEMI	Cross Reference				
	TYCO/Raychem	Littelfuse	Bourns / Multifuse®	Polytronics / EVERFUSE®	SEA-LAND
JSMD0603-005	femtoSMDC005F	-	-	-	SMD0603-005
JSMD0603-010	femtoSMDC010F	0603L010	MF-FSMF010X	SMD0603P010TF	SMD0603-010
JSMD0603-020	femtoSMDC020F	0603L020	MF-FSMF020X	SMD0603P020TF	SMD0603-020
JSMD0603-035	femtoSMDC035F	0603L035	MF-FSMF035X	SMD0603P035TF	SMD0603-030
JSMD0603-050	-	0603L050	MF-PSMF050X	SMD0603P050TF	SMD0603-050

“Raychem” is a registered trademark of Tyco Electronics.

“Littelfuse” is a registered trademark of Littelfuse.

“Multifuse” is a registered trademark of bourns,Inc.

“EVERFUSE” is a registered trademark of Polytronics Technology Corp.

“SEA-LAND” is a registered trademark of Sea-Land electronic corp.

Website: <http://www.jksemit.com>

For additional information, please contact your local Sales Representative.

©Copyright 2016, jksemit



is a registered trademark of jksemit All rights are reserved

单击下面可查看定价，库存，交付和生命周期等信息

[>>JKSEMI\(金开盛\)](#)