

Features

- Maximum output current is 1.2A
- Range of operation input voltage: Max 15V
- Line regulation: 0.03%/V (typ.)
- Standby current: 2mA (typ.)
- Load regulation: 0.2%/A (typ.)
- Environment Temperature: -20°C~85°C

Applications

- Power Management for Computer Mother Board, Graphic Card
- LCD Monitor and LCD TV
- DVD Decode Board
- ADSL Modem
- Post Regulators For Switching Supplies

General Description

SAMS1117-ADJ is a series of low dropout three-terminal regulators with a dropout of 13V at 800mA load current. SAMS1117-5.0V features a very low standby current 2mA compared to 5mA of competitor.

Other than a fixed version, $V_{out} = 1.2V, 1.8V, 2.5V, 2.85V, 3.3V,$ and 5V, SAMS1117-5.0V has an adjustable version, which

can provide an output voltage from 1.25 to 12V with only two external resistors.

SAMS1117 offers thermal shut down function, to assure the stability of chip and power system. And it uses trimming technique to guarantee output voltage accuracy within 2%. Other output voltage accuracy can be customized on demand, such as 1%.

SAMS1117 is available in SOT-223, TO-252, SOT-89 power package.

Typical Application

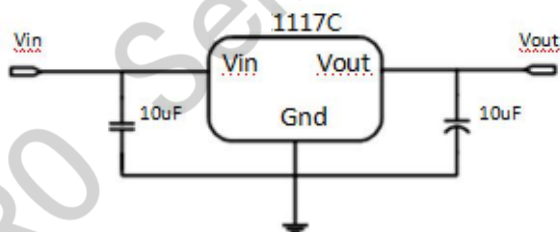

Application circuit of SAMS1117 fixed version

Typical Electrical Characteristic

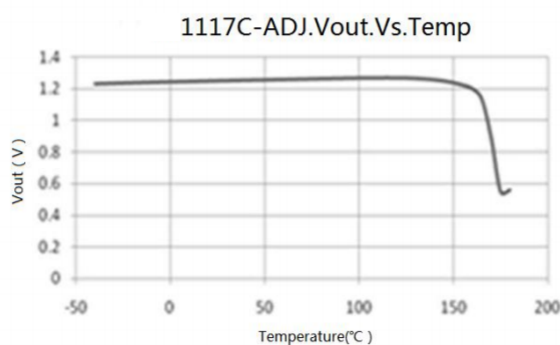

Selection Table

Marking	Part No.	Output Voltage	Package
1117 XXYYWW	XX=12	1.2V	SOT-223 TO-252 SOT-89
	XX=18	1.8V	
	XX=28	2.85V	
	XX=25	2.5V	
	XX=33	3.3V	
	XX=50	5.0V	
	XX=AD	Adj	

Ordering Information

Marking	Designator	Description
1117 XXYYWW	1117	Product code
	XX	Output Voltage(1.2~12.0V)
	YYWW	DATE CODE

Note: "XX" stands for output voltages. Other voltages can be specially customized

Parameters	Description
Temperature&RoHS	C: -40~85°C , Pb Free RoHS Std.
Package type	L: SOT-223 O: TO-252
Packing type:	TR: Tape&Reel (Standard)
Voltage accuracy	2%(Customized)

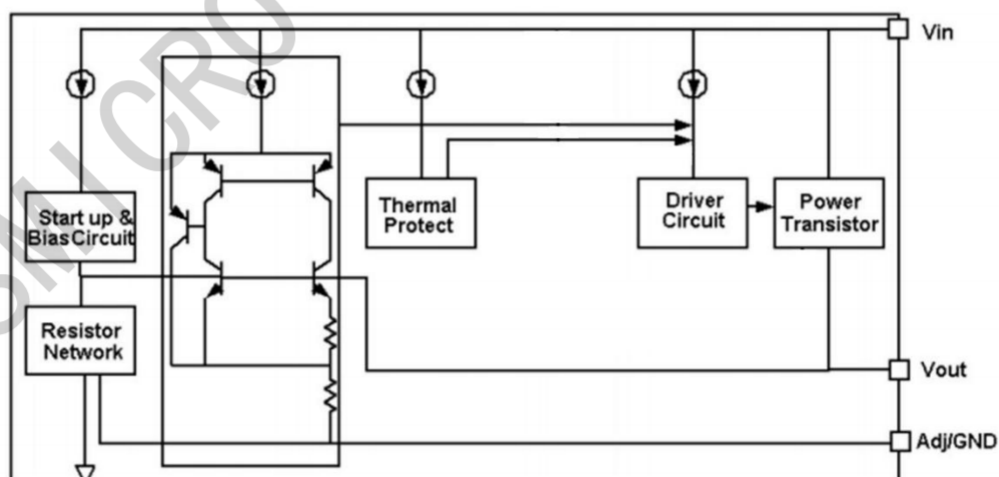
Block Diagram

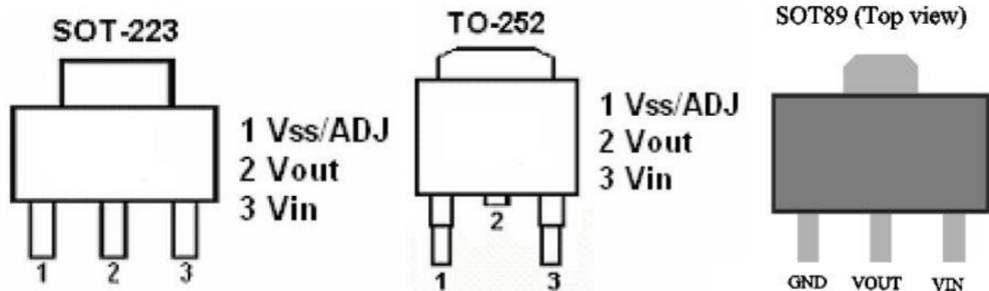
Pin Configuration



Absolute Maximum Ratings

Max Input Voltage	30V
Max Operating Junction Temperature(Tj)	150°C
Ambient Temperature(Ta)	-40°C~ 85°C
Storage Temperature(Ts)	-40°C~150°C
Lead Temperature & Time	260°C 10S

Caution: Exceed these limits to damage to the device. Exposure to absolute maximum rating conditions may affect device reliability.

Recommended Work Conditions

Recommended maximum input voltage	15V
Recommended operating junction temperature(Tj)	-20~125°C

Thermal Information

Parameter	Package	Rating	Unit
Package thermal resistance	SOT-223	20	°C/W
	TO-252	12.5	°C/W
	SOT89	200	°C/W

Electrical Characteristics
 $T_A=25^{\circ}\text{C}$, unless otherwise noted.

Symbol	Parameter	Conditions	Min	Typ	Max	Unit
Vref	Reference voltage	SAMS1117-Adj $10\text{mA} \leq I_{\text{out}} \leq 800\text{mA}$, $V_{\text{in}}=3.25\text{V}$	1.225	1.25	1.275	V
Vout	Output voltage	SAMS1117-1.2V $0 \leq I_{\text{out}} \leq 800\text{mA}$, $V_{\text{in}}=3.2\text{V}$	1.176	1.2	1.224	V
		SAMS1117-1.8V $0 \leq I_{\text{out}} \leq 800\text{mA}$, $V_{\text{in}}=3.8\text{V}$	1.764	1.8	1.836	V
		SAMS1117-2.5V $0 \leq I_{\text{out}} \leq 800\text{mA}$, $V_{\text{in}}=4.5\text{V}$	2.45	2.5	2.55	V
		SAMS1117-2.85V $0 \leq I_{\text{out}} \leq 800\text{mA}$, $V_{\text{in}}=4.85\text{V}$	2.793	2.85	2.907	V
		SAMS1117-3.3V $0 \leq I_{\text{out}} \leq 800\text{mA}$, $V_{\text{in}}=5.3\text{V}$	3.234	3.3	3.366	V
		SAMS1117-5.0V $0 \leq I_{\text{out}} \leq 800\text{mA}$, $V_{\text{in}}=7.0\text{V}$	4.9	5	5.1	V

ΔV_{out}	Line regulation	SAMS1117-1.2V $I_{\text{out}}=10\text{mA}$, $2.7\text{V} \leq V_{\text{in}} \leq 10\text{V}$		0.03	0.2	%/V
		SAMS1117-ADJ $I_{\text{out}}=10\text{mA}$, $2.75\text{V} \leq V_{\text{in}} \leq 12\text{V}$		0.03	0.2	%/V
		SAMS1117-1.8V $I_{\text{out}}=10\text{mA}$, $3.3\text{V} \leq V_{\text{in}} \leq 12\text{V}$		0.03	0.2	%/V
		SAMS1117-2.5V $I_{\text{out}}=10\text{mA}$, $4.0\text{V} \leq V_{\text{in}} \leq 12\text{V}$		0.03	0.2	%/V
		SAMS1117-2.85V $I_{\text{out}}=10\text{mA}$, $4.35\text{V} \leq V_{\text{in}} \leq 12\text{V}$		0.03	0.2	%/V
		SAMS1117-3.3V $I_{\text{out}}=10\text{mA}$, $4.8\text{V} \leq V_{\text{in}} \leq 12\text{V}$		0.03	0.2	%/V
		SAMS1117-5.0V $I_{\text{out}}=10\text{mA}$, $6.5\text{V} \leq V_{\text{in}} \leq 12\text{V}$		0.03	0.2	%/V

ΔV_{out}	Load regulation	SAMS1117-1.2V $V_{\text{in}}=2.7\text{V}$, $10\text{mA} \leq I_{\text{out}} \leq 800\text{mA}$		2	8	mV
		SAMS1117-ADJ $V_{\text{in}}=2.75\text{V}$, $10\text{mA} \leq I_{\text{out}} \leq 800\text{mA}$		2	8	mV
		SAMS1117-1.8V $V_{\text{in}}=3.3\text{V}$, $10\text{mA} \leq I_{\text{out}} \leq 800\text{mA}$		3	12	mV
		SAMS1117-2.5V $V_{\text{in}}=4.0\text{V}$, $10\text{mA} \leq I_{\text{out}} \leq 800\text{mA}$		4	16	mV

		SAMS1117-2.85V Vin =4.35V, 10mA ≤ Iout ≤ 800mA	5	20	mV
		SAMS1117-3.3 Vin =4.8V, 10mA ≤ Iout ≤ 800mA	6	24	mV
		SAMS1117-5.0 Vin =6.5V, 10mA ≤ Iout ≤ 800mA	9	36	mV
Vdrop	Dropout voltage	Iout =100mA	1.2	1.3	V
		Iout=800mA	1.3	1.5	V
Imin	Minimum load current	SAMS1117-ADJ	2	10	mA
Iq	Quiescent Current	SAMS1117-1.2V, Vin=10V	2	5	mA
		SAMS1117-1.8V, Vin=12V	2	5	mA
		SAMS1117-2.5V, Vin=12V	2	5	mA
		SAMS1117-2.85V, Vin=12V	2	5	mA
		SAMS1117-3.3V, Vin=12V	2	5	mA
		SAMS1117-5.0V, Vin=12V	2	5	mA
IAdj	Adjust pin current	SAMS1117-ADJ Vin=5V, 10mA ≤ Iout ≤ 800mA	55	120	uA
Ichange	Iadj change	SAMS1117-ADJ Vin=5V, 10mA ≤ Iout ≤ 800mA	0.2	10	uA
ΔV/ΔT	Temperature coefficient		±100		ppm
θ _{JC}	Thermal resistance	SOT-223	20		°C/W
		TO-252	10		

Note1: All test are conducted under ambient temperature 25°C and within a short period of time 20ms

Note2: Load current smaller than minimum load current of SAMS1117-ADJ will lead to unstable or oscillation output.

Detailed Description

SAMS1117 is a series of low dropout voltage, three terminal regulators. Its application circuit is very simple: the fixed version only needs two capacitors and the adjustable version only needs two resistors and two capacitors to work. It is composed of some modules including start-up circuit, bias circuit, bandgap, thermal shutdown, power transistors and its driver circuit and so on.

The thermal shut down modules can assure chip and its application system working safety when the junction temperature is larger than 140°C.

The bandgap module provides stable reference voltage, whose temperature coefficient is compensated by careful design considerations. The temperature coefficient is under 100 ppm/°C. And the accuracy of output voltage is guaranteed by trimming technique.

Typical Application

SAMS1117 has an adjustable version and six fixed versions (1.2V, 1.8V, 2.5V, 2.85V, 3.3V and 5V)

Fixed Output Voltage Version

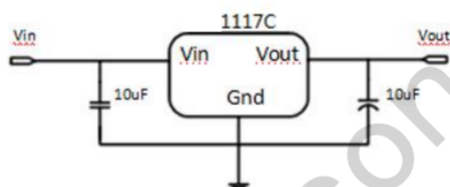

Application circuit of SAMS1117 fixed version

- 1) Recommend using 10uF tan capacitor as bypass capacitor (C1) for all application circuit.
- 2) Recommend using 10uF tan capacitor to assure circuit stability.

Adjustable Output Voltage Version

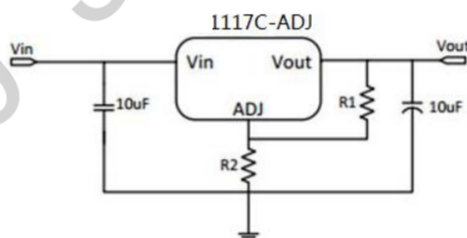

Application Circuit of SAMS1117-ADJ

The output voltage of adjustable version follows the equation: $V_{out} = 1.25 \times (1 + R2/R1) + I_{Adj} \times R2$. We can ignore I_{Adj} because I_{Adj} (about 50uA) is much less than the current of $R1$ (about 2~10mA).

1) To meet the minimum load current (>10mA) requirement, $R1$ is recommended to be 125ohm or lower. As HS1117C-ADJ can keep itself stable at load current about 2mA, $R1$ is not allowed to be higher than 625ohm.

2) Using a bypass capacitor (C_{ADJ}) between the ADJ pin and ground can improve ripple rejection. This bypass capacitor prevents ripple from being amplified as the output voltage is increased. The impedance of C_{ADJ} should be less than $R1$ to prevent ripple from being amplified. As $R1$ is normally in the range of 100Ω~500Ω, the value of C_{ADJ} should satisfy this equation: $1/(2\pi \times f_{ripple} \times C_{ADJ}) < R1$.

Thermal Considerations

We have to take heat dissipation into great consideration when output current or differential voltage of input and output voltage is large. Because in such cases, the power dissipation consumed by SAMS1117 is very large. SAMS1117 series uses SOT-223 package type and its thermal resistance is about 20°C/W. And the copper area of application board can affect the total thermal resistance. If copper area is 5cm*5cm (two sides), the resistance is about 30°C/W. So the total thermal resistance is about 20°C/W + 30°C/W. We can decrease total thermal resistance by increasing copper area in application board. When there is no good heat dissipation copper area in PCB, the total thermal resistance will be as high as 120°C/W, then the power dissipation of SAMS1117 could allow on itself is less than 1W. And furthermore, SAMS1117 will work at junction temperature higher than 125°C under such condition and no lifetime is guaranteed.

Typical Performance Characteristics

T_A=25°C, unless otherwise noted.

Line regulation

1117C-ADJ V_{out} Vs. V_{in}

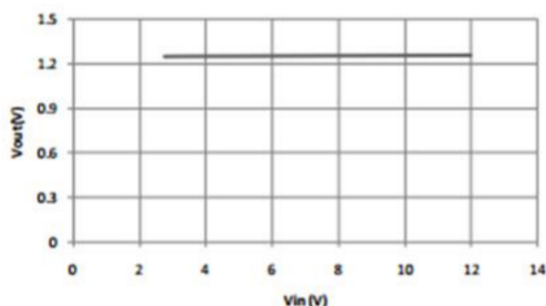

Load regulation

1117C-ADJ V_{out} Vs. I_{out}

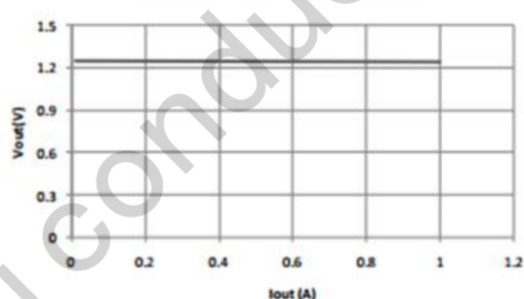

Dropout voltage

Dropout voltage

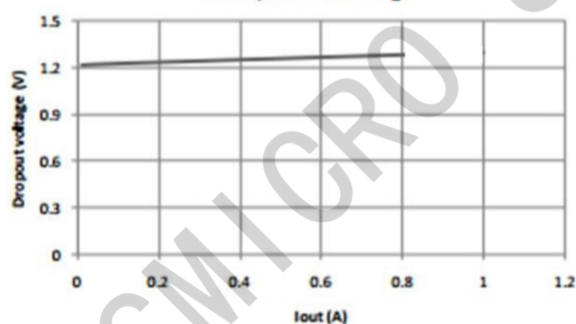

Thermal performance with OTP

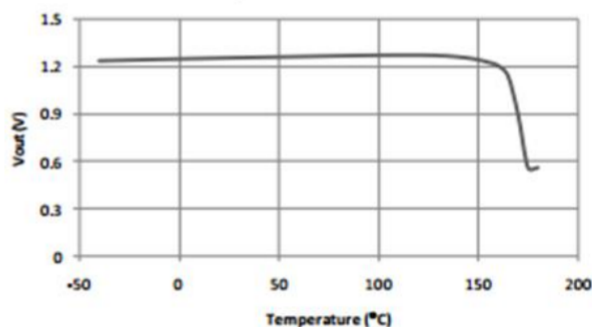

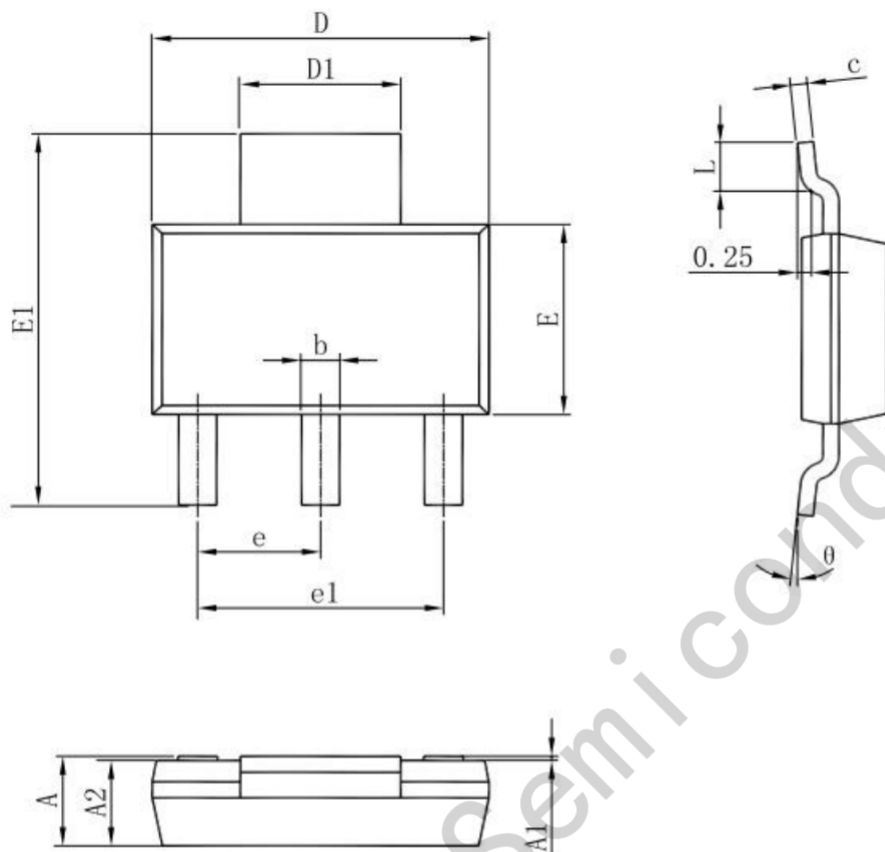
Package Information
SOT-223 PACKAGE OUTLINE DIMENSIONS

Symbol	Dimensions In Millimeters		Dimensions In Inches	
	Min	Max	Min	Max
A	1.520	1.800	0.060	0.071
A1	0.000	0.100	0.000	0.004
A2	1.500	1.700	0.059	0.067
b	0.660	0.820	0.026	0.032
c	0.250	0.350	0.010	0.014
D	6.200	6.400	0.244	0.252
D1	2.900	3.100	0.114	0.122
E	3.300	3.700	0.130	0.146
E1	6.830	7.070	0.269	0.278
e	2.300(BSC)		0.091(BSC)	
e1	4.500	4.700	0.177	0.185
L	0.900	1.150	0.035	0.045
θ	0°	10°	0°	10°

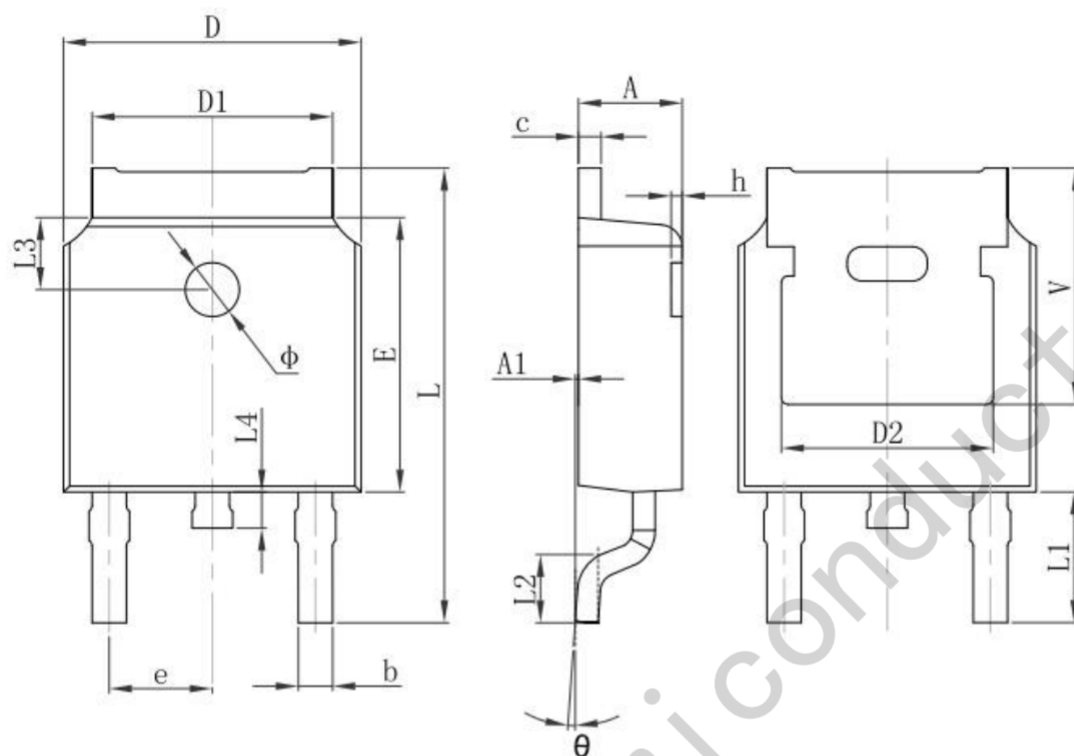
TO-252-2L PACKAGE OUTLINE DIMENSIONS

Symbol	Dimensions In Millimeters		Dimensions In Inches	
	Min.	Max.	Min.	Max.
A	2.200	2.400	0.087	0.094
A1	0.000	0.127	0.000	0.005
b	0.660	0.860	0.026	0.034
c	0.460	0.580	0.018	0.023
D	6.500	6.700	0.256	0.264
D1	5.100	5.460	0.201	0.215
D2	4.830 REF.		0.190 REF.	
E	6.000	6.200	0.236	0.244
e	2.186	2.386	0.086	0.094
L	9.800	10.400	0.386	0.409
L1	2.900 REF.		0.114 REF.	
L2	1.400	1.700	0.055	0.067
L3	1.600 REF.		0.063 REF.	
L4	0.600	1.000	0.024	0.039
Φ	1.100	1.300	0.043	0.051
θ	0°	8°	0°	8°
h	0.000	0.300	0.000	0.012
V	5.350 REF.		0.211 REF.	

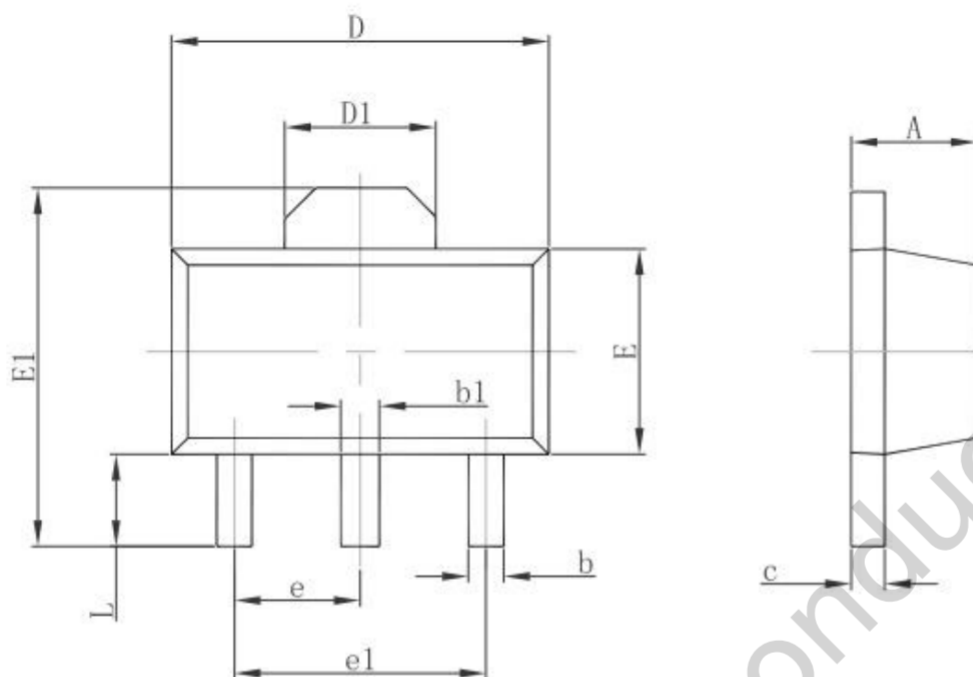
3-pin SOT89 Outline Dimensions

Symbol	Dimensions In Millimeters		Dimensions In Inches	
	Min.	Max.	Min.	Max.
A	1.400	1.600	0.055	0.063
b	0.320	0.520	0.013	0.020
b1	0.400	0.580	0.016	0.023
c	0.350	0.440	0.014	0.017
D	4.400	4.600	0.173	0.181
D1	1.550 REF.		0.061 REF.	
E	2.300	2.600	0.091	0.102
E1	3.940	4.250	0.155	0.167
e	1.500 TYP.		0.060 TYP.	
e1	3.000 TYP.		0.118 TYP.	
L	0.900	1.200	0.035	0.047

单击下面可查看定价，库存，交付和生命周期等信息

[>>JSMSEMI\(杰盛微\)](#)