

Schottky Barrier Diode

FEATURES

- Low Forward Voltage Drop
- Guard Ring Construction for Transient Protection
- Negligible Reverse Recovery Time
- Low Capacitance

PINNING

PIN	DESCRIPTION
1	Cathode
2	Anode

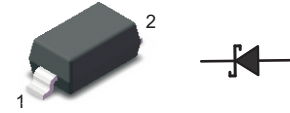

Top View
 Marking Code: S4
 Simplified outline SOD-123 and symbol

MECHANICAL DATA

- Case: SOD-123
- Terminals: Solderable per MIL-STD-750, Method 2026
- Approx. Weight: 16mg/0.00056oz

Maximum Ratings and Electrical characteristics

Ratings at 25 °C ambient temperature unless otherwise specified.

Parameter	Symbols	1N5819W
Peak Repetitive Reverse Voltage	V_{RRM}	40V
RMS reverse voltage	V_{RMS}	28V
Working Peak Reverse Voltage	V_{DC}	40V
Peak Forward Surge Current, 8.3ms single half sine-wave superimposed on rated load (JEDEC method)	I_{FSM}	13A
Maximum Instantaneous Forward Voltage $I_F=20mA$ $I_F=200mA$	V_F	0.37 V 0.60
Power Dissipation	P_D	400 mW
Reverse current $V_R=30V$ $V_R=20V$ $V_R=10V$	I_R	5 – uA –
Thermal Resistance, Junction to Ambient Air	$R_{\theta JA}$	300°C/W
Reverse voltage $I_R=100\mu A$ IN5819W	$V_{(BR)}$	40V
Reverse recovery time $I_F=I_R=200mA, I_{rr}=0.1 \times I_R, R_L=100\Omega$	t_{rr}	10ns
Forward Continuons Current	I_{FM}	350mA
Total capacitance $V_R=0V, f=1MHz$	C_{tot}	28pF
Junction temperature	T_j	125°C
Storage temperature	T_{stg}	-55 ~ +150°C

Fig.1 Power Derating Curve

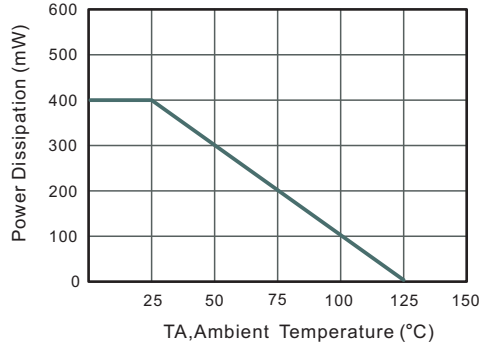

Fig.2 Typical Reverse Characteristics

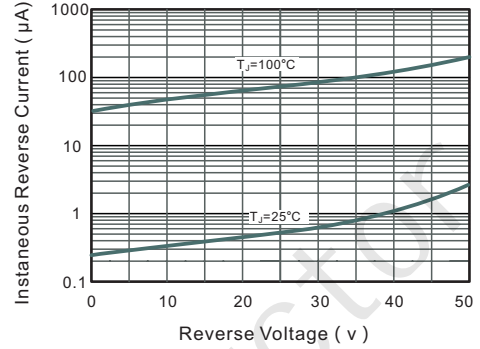

Fig.3 Forward Characteristics

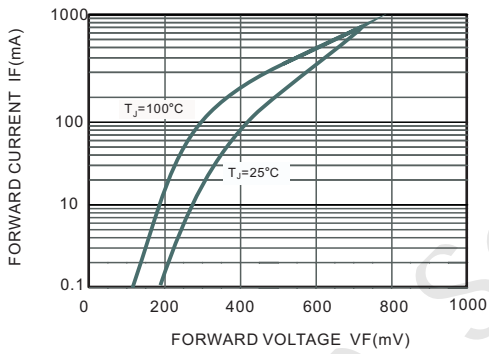

Fig.4 Maximum Non-Repetitive Peak Forward Surge Current

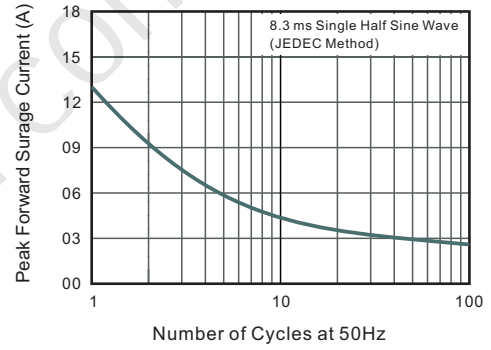

Fig.5 Typical Junction Capacitance

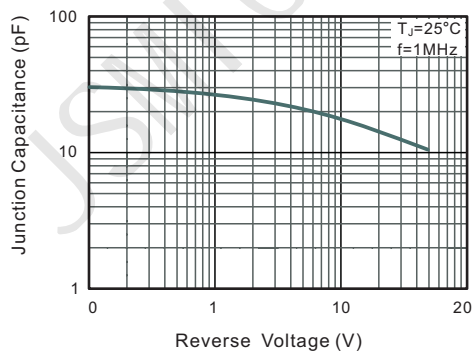
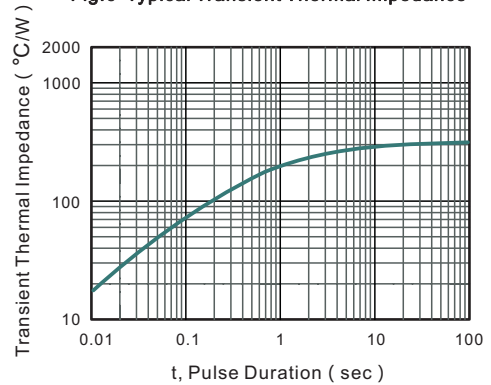

Fig.6 Typical Transient Thermal Impedance



PACKAGE OUTLINE

Plastic surface mounted package; 2 leads

SOD-123

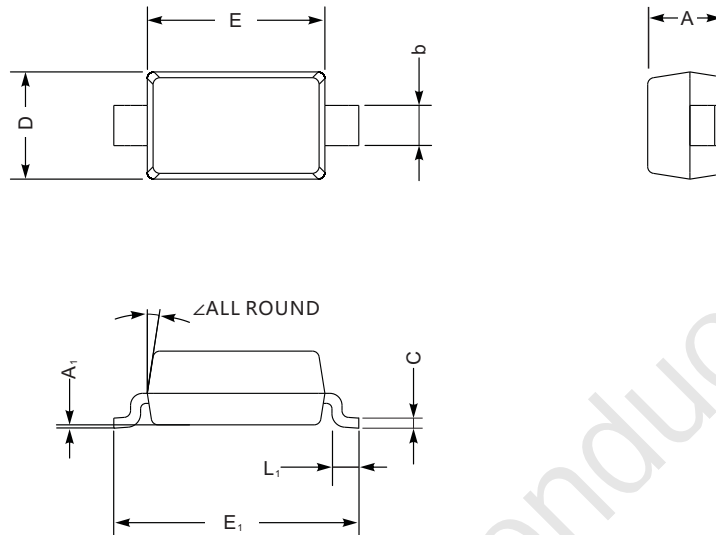

SOD-123 mechanical data

UNIT		A	C	D	E	E ₁	L ₁	b	A ₁	∠
mm	max	1.3	0.22	1.8	2.8	3.9	0.45	0.7	0.2	9°
	min	0.9	0.09	1.5	2.5	3.6	0.25	0.5	—	
mil	max	51	8.7	71	110	154	18	28	8	
	min	35	3.5	59	98	142	10	20	—	

The recommended mounting pad size

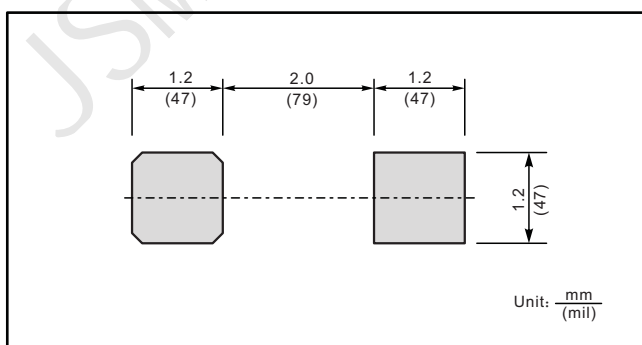

Marking

Type number	Marking code
1N5819W	S4

单击下面可查看定价，库存，交付和生命周期等信息

[>>JSMSEMI\(杰盛微\)](#)