

BNI CONNECTOR

3.3 mm pitch/For Wire-to-Board connection/Crimp style and Mating style

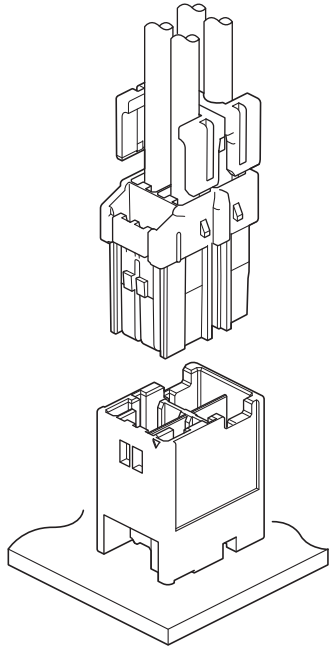

This is a 3.3 mm pitch wire-to-board connector with a mechanism to prevent incomplete mating. Three different key patterns per number of circuits in the same model are provided to prevent incorrect mating when multiple pieces of connector are used in close proximity.

- Keying structure
- Secure lock mechanism
- Inertia lock mechanism
- Retainer mountable type
- Suitable for potting process

Standards

Ⓜ: Recognized E 60389

Ⓢ: Certified LR 20812

Specifications

- Current rating: 4 A AC/DC (AWG #20)

* The following table shows the rated current when applying current for all circuits in each combination of the number of circuits and the wire to be used.

Unit: A

No. of circuits	Wire size (AWG)		
	#20	#22	#24
2	4	3	3
3	4	3	2
4	4	3	2
6	4	3	2
8	4	3	2
10	4	3	2
12	4	3	2

Notes on parallel branching current :

Do not branch to the multiple circuits in parallel current which exceeds the rated current, as it may cause problems such as imbalance when applying current.

If it is unavoidable that branch in parallel is necessary, design the circuits while suppressing the unbalanced current and proving the sufficient margin to the rated current.

- Voltage rating: 300 V AC/DC
 - Temperature range: -25°C to +85°C
(including temperature rise in applying electrical current)
 - Contact resistance:
 - Initial value/ 10 mΩ max.
 - After environmental tests/ 20 mΩ max.
 - Insulation resistance: 1,000 MΩ min.
 - Withstanding voltage:
 - There shall be no breakdown or flashover while applying 1,500 VAC for one minute.
 - Applicable wire:
 - Conductor size/ AWG #24 to AWG #20
 - Insulation O.D./ φ 1.3 mm to φ 2.5 mm
 - Applicable PC board thickness: 1.6 mm
- * In using the products, refer to "Handling Precautions for Terminals and Connectors" described on our website (Technical documents of Product information page).
- * RoHS2 compliance
 - * Dimensional unit: mm
 - * Contact JST for details.

BNI CONNECTOR

PC board layout and Assembly layout

Single-row

<2, 3 circuits>

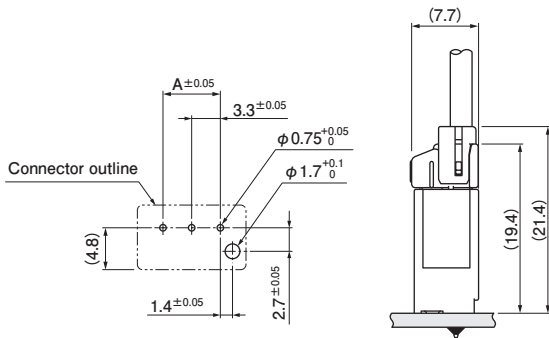

Dual-row

<4, 6, 8, 10, 12 circuits>

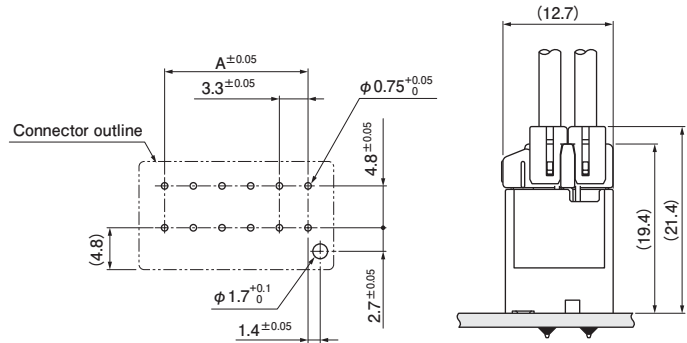

- Note: 1. The figure of PC board layout is the figure viewed from the connector mounting side .
 2. Dimension A: See section "Header" on page 4.
 3. Tolerance for the PCB hole pitch shall be ± 0.05 , and shall not accumulate more than ± 0.05 .
 4. Hole dimensions differ according to the type of PC board and piercing method.
 Please contact JST for details as the dimensions shown in the above figure are reference values.

Contact

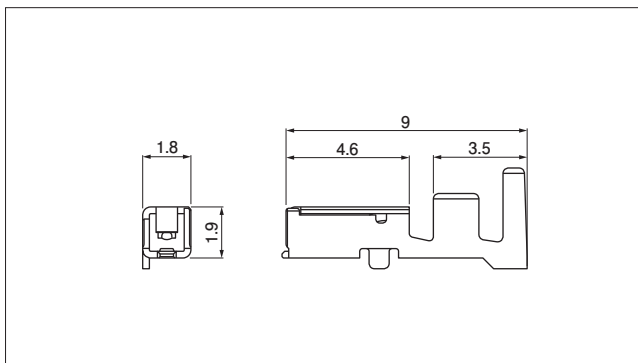

Model No.	Applicable wire range		Q'ty/ reel
	Conductor size AWG (mm ²)	Insulation O.D. (mm)	
SBNI-01T-P0.5	#24 to #20 (0.2 to 0.5)	1.3 to 2.5	5,000

Material and Finish			
Copper alloy, tin-plated			

Crimping machine

Contact	Crimping machine	Applicator	Crimp applicator with dies
SBNI-01T-P0.5	AP-K2N	MKS-L	APLMK SBNI01-05

Note: Contact JST for fully automatic crimping applicator.

Housing

Single-row <2 circuits>

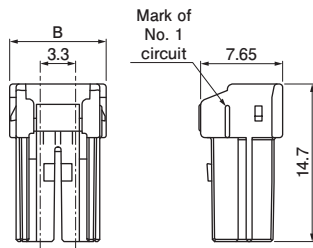

<3 circuits>

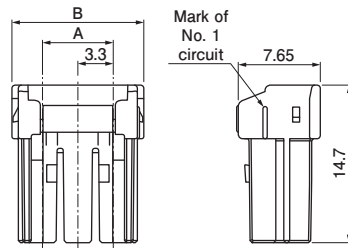

Dual-row <4 circuits>

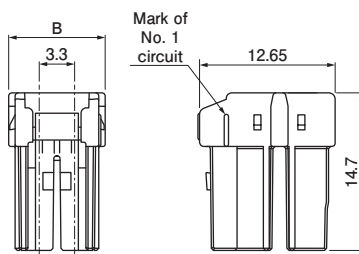

<6 circuits>

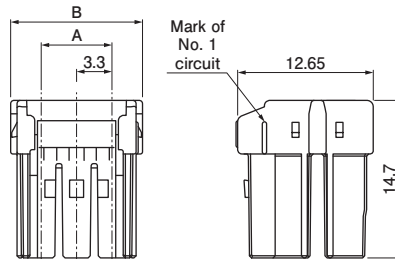

<8 circuits>

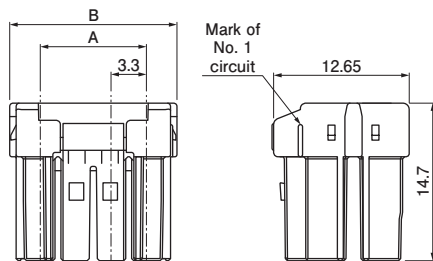

<10 circuits>

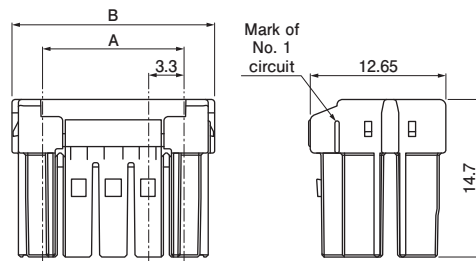

<12 circuits>

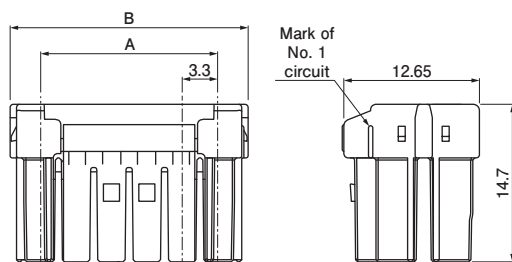

Type	No. of circuits	Model No.	Dimensions (mm)		Q'ty/bag
			A	B	
Single-row	2	BNIRP-02V-A-S	—	9.0	1,000
	3	BNIRP-03V-A-S	6.6	12.3	1,000
	4	BNIRP-04V-W-A-S	—	9.0	1,000
Dual-row	6	BNIRP-06V-W-A-S	6.6	12.3	1,000
	8	BNIRP-08V-W-A-S	9.9	15.6	1,000
	10	BNIRP-10V-W-A-S	13.2	18.9	500
	12	BNIRP-12V-W-A-S	16.5	22.2	500

Material and Finish

PA 66 (Glass-filled), UL94V-0, natural

Header

Single-row

<2 circuits>

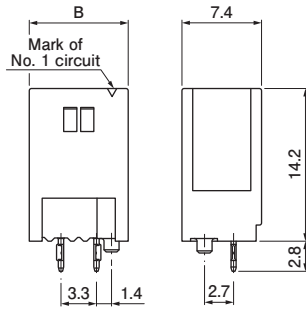

<3 circuits>

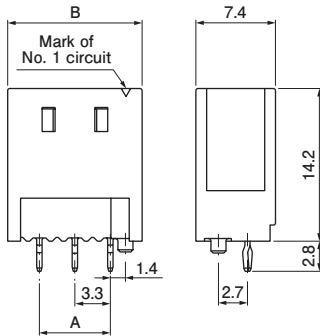

Dual-row

<4 circuits>

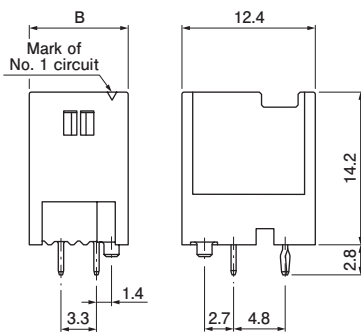

<6 circuits>

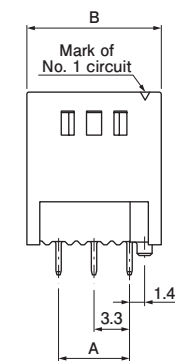

<8 circuits>

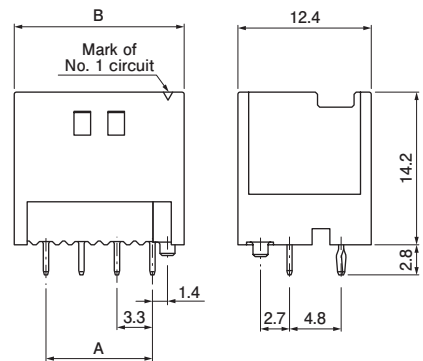

<10 circuits>

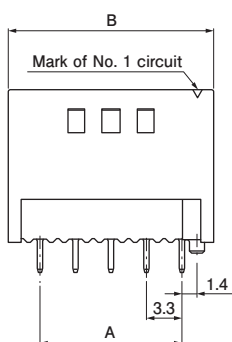

<12 circuits>

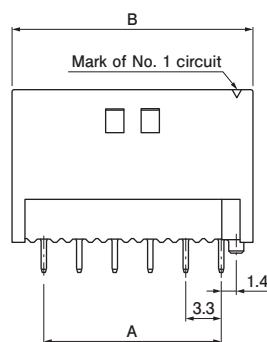

Type	No. of circuits	Model No.	Dimensions (mm)		Q'ty/bag
			A	B	
Single-row	2	B02B-BNISK-A-1	—	9.2	310
	3	B03B-BNISK-A-1	6.6	12.5	260
	4	B04B-BNISK-A-1W	—	9.2	210
Dual-row	6	B06B-BNISK-A-1W	6.6	12.5	170
	8	B08B-BNISK-A-1W	9.9	15.8	140
	10	B10B-BNISK-A-1W	13.2	19.1	110
	12	B12B-BNISK-A-1W	16.5	22.4	80

Material and Finish

Post: Copper alloy, copper-undercoated, tin-plated
 Wafer: PA 66 (Glass-filled), UL94V-0, natural

BNI CONNECTOR

Retainer

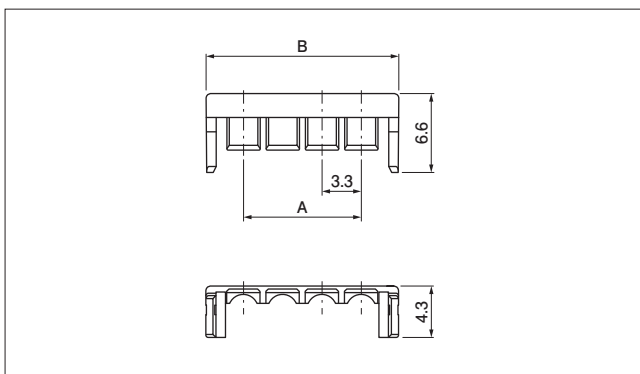

No. of circuits	Model No.	Dimensions (mm)		Q'ty/bag
		A	B	
2	BNIS-02V	—	9.6	2,000
3	BNIS-03V	6.6	12.9	2,000
4	BNIS-04V	9.9	16.2	2,000
5	BNIS-05V	13.2	19.5	1,000
6	BNIS-06V	16.5	22.8	1,000

Material and Finish
PA 66 (Glass-filled), UL94V-0, natural

Contact position location numbers

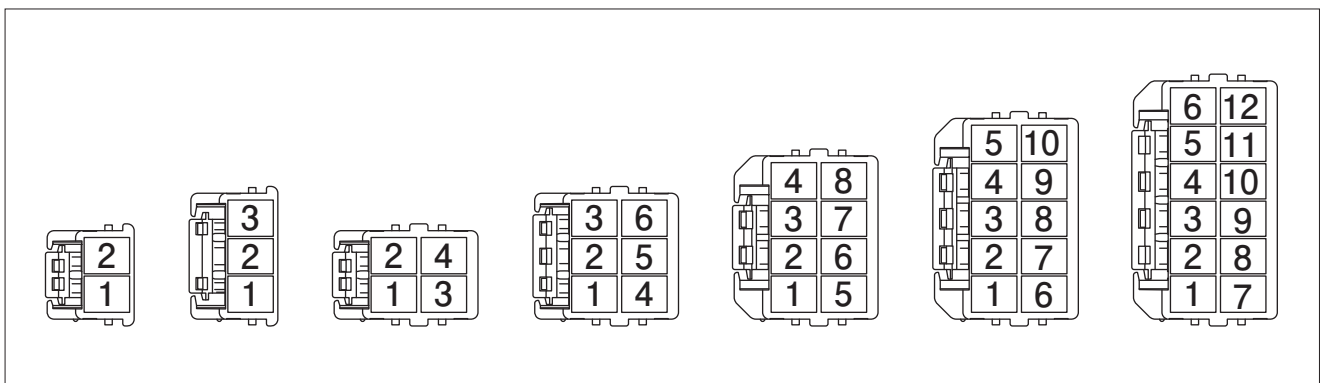

Product combination list

Key pattern	A	B	C
Color	Natural	Green	Blue
Single-row			
Header			
Housing Model No.	BNIRP-()V-()-A-S	BNIRP-()V-()-B-M	BNIRP-()V-()-C-E
Header Model No.	B()B-BNISK-A-1()	B()B-BNIMK-B-1()	B()B-BNIEK-C-1()

* The figures above show the top view of the header.

Model number allocation

Contact

S BNI - 01 T - P 0.5

Supply form: Strip form

Series name

Applicable wire range: AWG #24 to AWG #20

Surface finish: Tin-plated

Material: Copper alloy

Applicable post size

Housing

BNI RP - 04 V - W - A - S

Series name

Type: Retainer mountable type

No. of circuits

Flammability: UL94V-0

Arrangement: Blank...Single-row, W...Dual-row

Key pattern: A...Key pattern A
B...Key pattern B
C...Key pattern C

Color: S...Natural, M...Green, E...Blue

Header

B 04 B - BNI S K - A - 1 W

Header type:
Top entry type

No. of circuits

Assembly product

Series name

Color: S...Natural, M...Green, E...Blue

Clinched (Kinked) / Not clinched: Clinched

Key pattern: A...Key pattern A
B...Key pattern B
C...Key pattern C

Presence of boss: With boss

Arrangement: Blank...Single-row, W...Dual-row

Retainer

BNI S - 02 V

Series name

Type: Retainer

No. of circuits

Flammability: UL94V-0

单击下面可查看定价，库存，交付和生命周期等信息

[>>JST\(杰世腾\)](#)