

# CPM CONNECTOR

Wire-to-Board

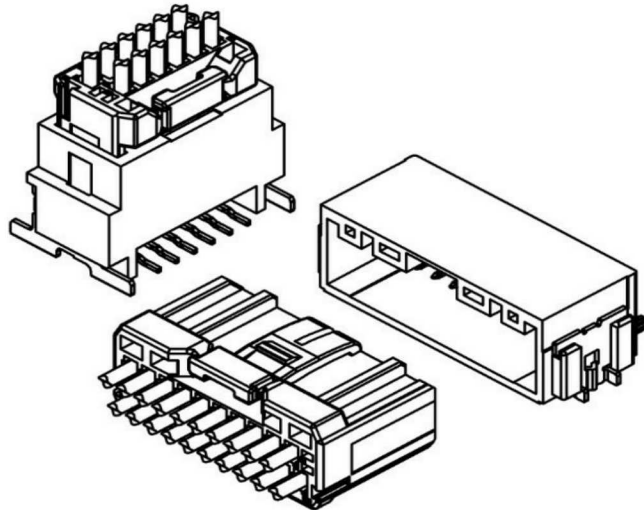

Miniaturized and low profile surface mounting type connector for automotive.  
0.50 terminal with 2.0 mm pitch realized its miniaturization.



## ■ Features

### ● Miniaturized and Low Profile

Miniaturized and low profile automotive connector which pitch is width: 2.0 mm and length: 2.5 mm by using the 0.5 terminal.

### ● High Heat Resistance 125°C

Conforming a heat resistant temperature of 125°C.

### ● Lock Flip-up Prevention Mechanism

Low profile connector which has the mechanism to prevent the lock damage by catching the wire cables.

### ● Conforming to UL94 V-0

Using UL94 V-0 material to meet the increasing market demand of the flame-retardant requirement.

### ● Same PCB Pattern as CPT

Applying the same PCB layout of CPT connector.

## ■ Specifications

Item	Standard	Condition
● Current rating	3A AC,DC Max	Applying 0.3mm <sup>2</sup>
● Temperature range	-40°C ~ +125°C	Including temperature rise in applying electrical current
● Applicable wire	UL3265 0.3mm <sup>2</sup> AESSX 0.3mm <sup>2</sup> (Equivalent of AWG#22)	Coating OD: Φ1.5mm max
● Frame resistance	V-0	UL94
● Contact resistance	Initial 25mΩ max After environmental test 25mΩ max	DC 100mA
● Insulation resistance	100MΩ min	DC 500V
● Withstand voltage	No dielectric breakdown	AC 1,000V / min.
● Locking force	110N min	In case pulling to mating direct

## ■ Test Result

Item	Test Result	Condition
● Heat resistance	Initial 15mΩ max	Under 125°C, Abandoned for 1,008 hours
● Thermal shock resistance	Initial 15mΩ max	-40°C/125°C 30 min / 1000cyc / each
● Vibration resistance	Initial 15mΩ max	USCAR2 V2

\*Compliant with ELV/RoHS2.

\*Contact JST for details.

**Female Terminal**

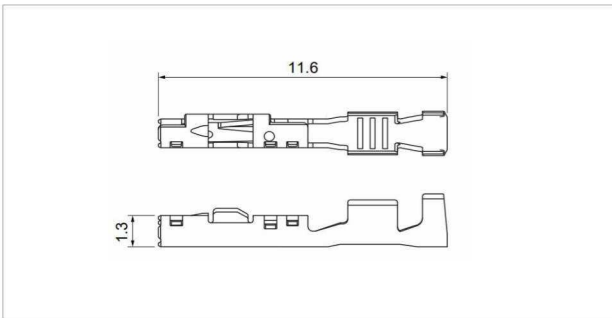

Model No.	Applicable wire range		Q'ty/reel
	Conductor (mm <sup>2</sup> )	Insulation O.D. (mm)	
<b>SMEC-A021T-M0.5</b>	0.3	1.5 max.	12,000

Material and Finish  
Copper alloy, tin-plated

**Female Connector**

● 8 circuits

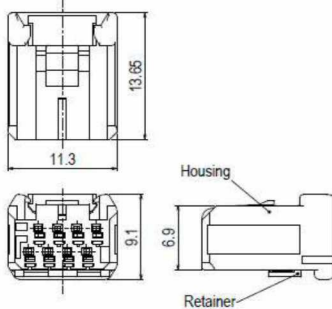

● 12 circuits

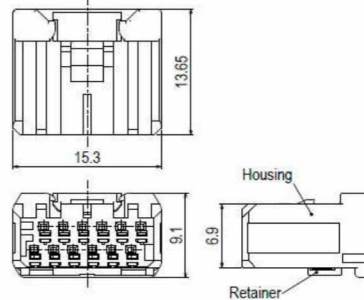

● 16 circuits

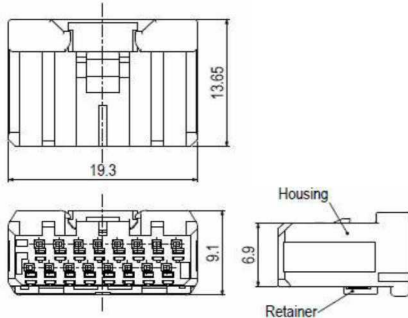

● 20 circuits

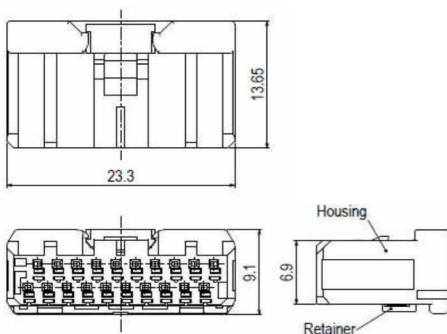

Circuits	Model No.	Housing Color	Q'ty/box
8	<b>08CPM-BVK-2-AA</b>	Black	4,800
12	<b>12CPM-BVK-2-AA</b>	Black	3,600
16	<b>16CPM-BVK-2-AA</b>	Black	2,400
20	<b>20CPM-BVK-2-AA</b>	Black	1,200

Material and Finish

Housing: Glass-filled PBT  
Retainer: Glass-filled PBT, Natural (White)

Note: Color/Key codes other than above-mentioned housing are also available. Contact JST for details.

## Male Connector

### Top Type

#### ● 8 circuits

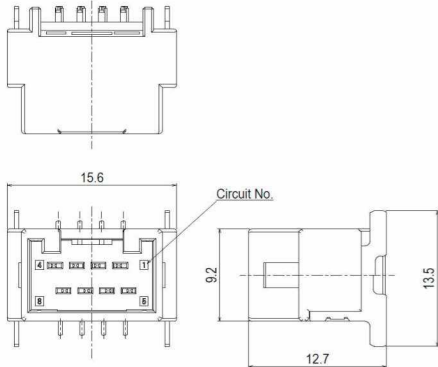

#### ● 12 circuits

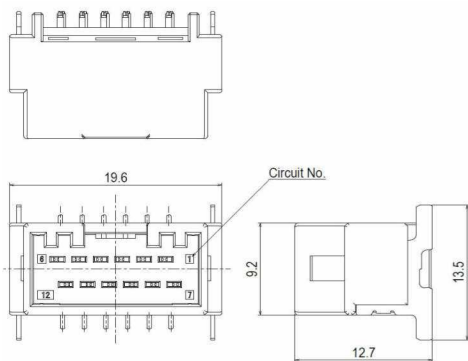

Circuits	Model No.	Housing Color	Qty/box
8	<b>BM08B-CPMK-2AA-(# #)</b>	Black	1,100
12	<b>BM12B-CPMK-2AA-(# #)</b>	Black	880

#### Material and Finish

Housing: Glass-filled LCP

Suction cap: PA9T

Male Terminal: Copper alloy, tin-plated

Tab: Copper alloy, tin-plated

Note: Color/Key codes other than above-mentioned housing are also available. Contact JST for details.

(# #) denotes emboss specifications. TB: Normal, ETB: Antistatic

Male Connector

Side Type

● 8 circuits

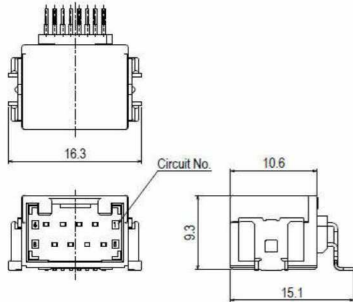

● 12 circuits

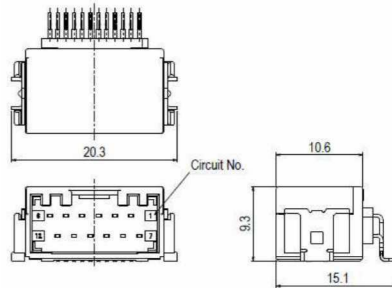

● 16 circuits

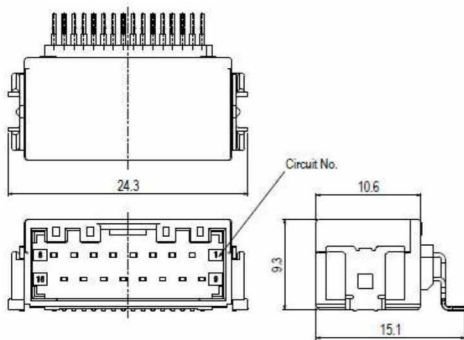

● 20 circuits

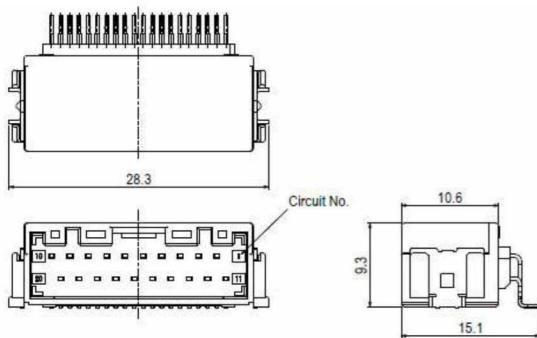

Circuits	Model No.	Housing Color	Q'ty/box
8	SM08B-CPMK-2AA-(# #)	Black	1,600
12	SM12B-CPMK-2AA-(# #)	Black	1,280
16	SM16B-CPMK-2AA-(# #)	Black	1,280
20	SM20B-CPMK-2AA-(# #)	Black	1,280

Material and Finish

Housing: Glass-filled LCP

Male Terminal: Copper alloy, tin-plated

Tab: Copper alloy, tin-plated

Note: Color/Key codes other than above-mentioned housing are also available. Contact JST for details.

(# #) denotes emboss specifications. TB: Normal, ETB: Antistatic

**Taping Specification Top Type**

● 8, 12 circuits

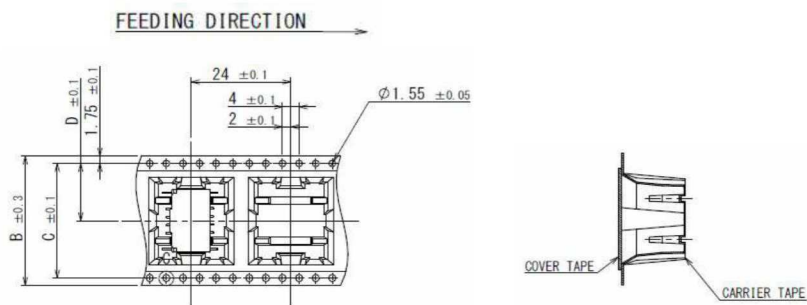
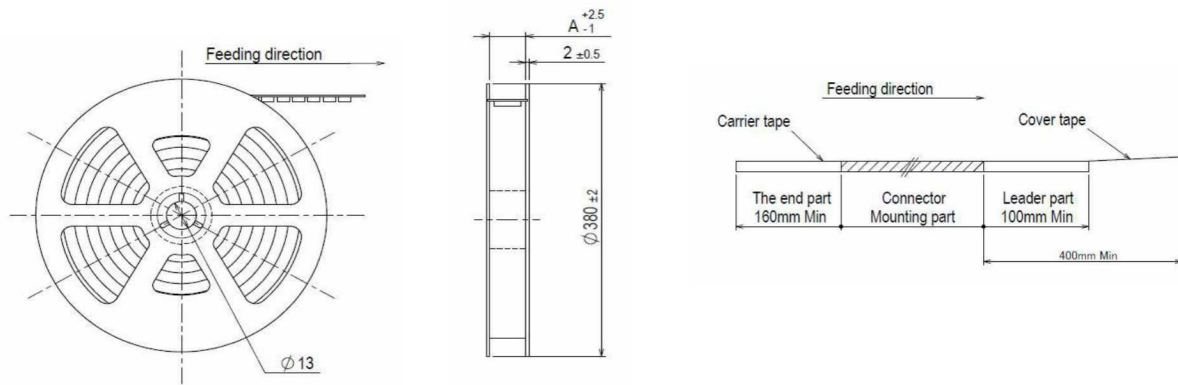

Circuits	A	B	C	D
8	33.4	32	28.4	14.2
12	45.4	44	40.4	20.2

Taping Specification Side Type

● 8, 12, 16, 20 circuits

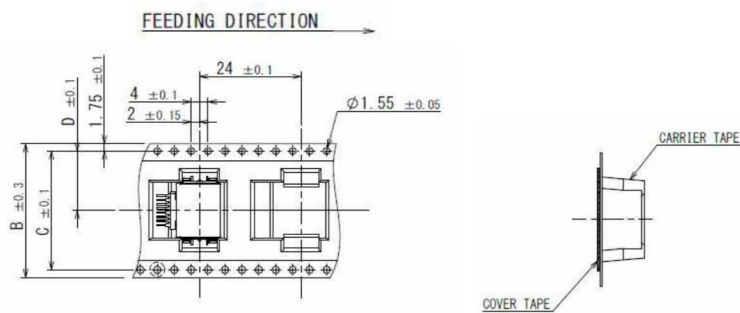
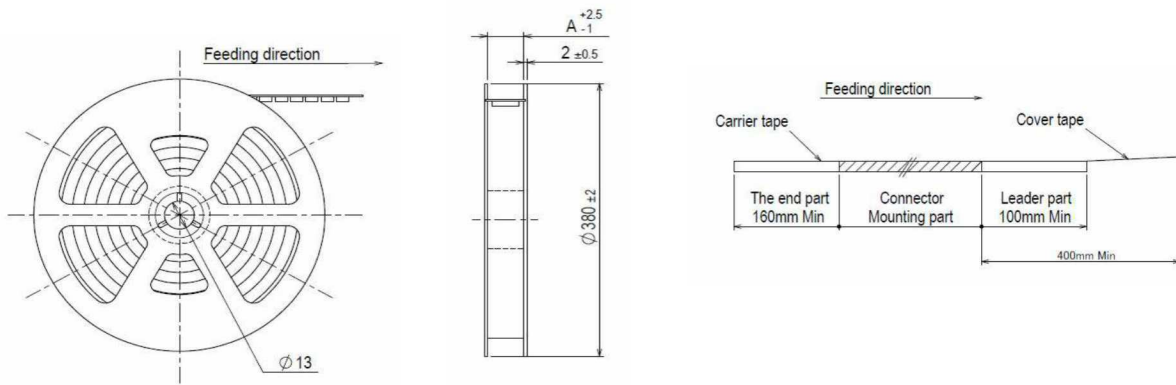

Circuits	A	B	C	D
8	33.4	32	28.4	14.2
12~20	45.4	44	40.4	20.2

**PC board layout (Viewed from component side), Assembly layout**

**Top Type**

**PC board layout**  
● 8, 12 circuits

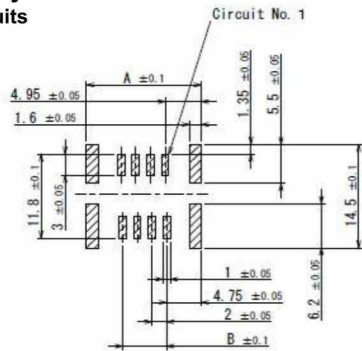

Circuits	A	B
8	15.7	6
12	19.7	10

**Assembly layout**  
● 8, 12 circuits

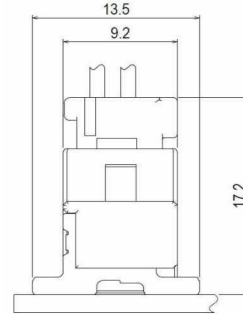

**Side Type**

**PC board layout**  
● 8, 12, 16, 20 circuits

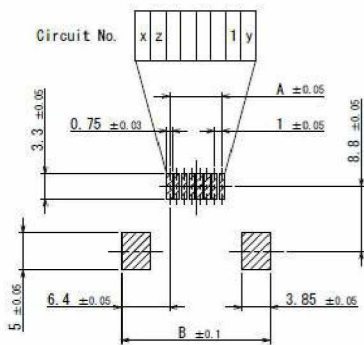
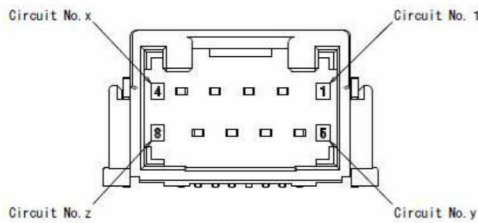

Circuits	A	B
8	7	19.8
12	11	23.8
16	15	27.8
20	19	31.8

**Assembly layout**

● 8, 12, 16, 20 circuits

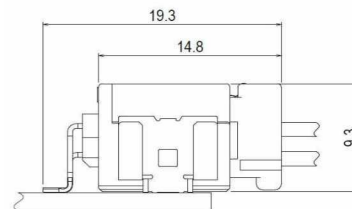

**Crimping machine, Applicator**

Strip terminal	Crimping machine	Crimp applicator MKS-L	
		Dies	Crimp applicator with dies
<b>SMEC-A021T-M0.5</b>	AP-K2N	MK/SMEC-A021-05	APLMK SMEC-A021-05

Note: 1. Contact JST for details.

2. When crimping operation is conducted using an applicator and die set other than the above, JST cannot guarantee the performance of the terminal.

单击下面可查看定价，库存，交付和生命周期等信息

[>>JST\(杰世腾\)](#)