

Solderless terminals

RING TONGUE (R type) Non-insulated

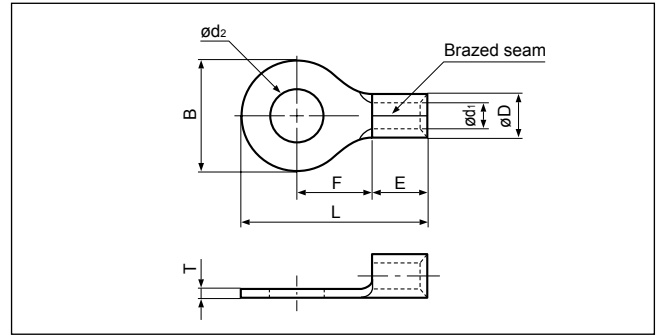

JQ0608019
 JQID08002
 JQMY14001
 JIS C 2805

Certificate No.: E42024 LR20812

JIS

Applicable Wire AWG#(mm ²)	Stud size		Part No.		Standard	Dimensions mm (in.)								Tool No.	Qty/box
	American	Metric	JST	JIS		ϕd_2	B	L	F	E	ϕD	ϕd_1	T		
26 to 22 (0.2 to 0.5)	1-2	2	0.5-2			2.2 (.087)	5.2 (.205)	12.4 (.488)	5.8 (.228)	4.0 (.157)	2.0 (.079)	1.0 (.039)	0.5 (.020)	YHT-2622 YA-1 YA-2 BCT-0514L	1,000
	3-4	3	0.5-3			3.2 (.126)	5.2 (.205)	12.4 (.488)	5.8 (.228)						
	5-6	3.5	0.5-3.7			3.7 (.146)	6.6 (.260)	15.0 (.591)	7.7 (.303)						
	8	4	0.5-4			4.3 (.169)	6.6 (.260)	15.0 (.591)	7.7 (.303)						
	10	5	0.5-5			5.3 (.209)	8.0 (.315)	15.0 (.591)	7.0 (.276)						
22 to 16 (0.25 to 1.65)	1-2	2	1.25-2			2.2 (.087)	5.5 (.217)	11.5 (.453)	4.0 (.157)	4.8 (.189)	3.4 (.134)	1.7 (.067)	0.8 (.031)	YHT-2210 YA-1 YA-2 YA-4 BCT-0514L	1,000
	3-4	3	1.25-3	R1.25-3		3.2 (.126)	5.5 (.217)	11.5 (.453)	4.0 (.157)						
	3-4	3	1.25-MS3			3.2 (.126)	5.5 (.217)	13.2 (.520)	5.6 (.220)						
	3-4	3	1.25-M3.3			3.2 (.126)	6.6 (.260)	14.4 (.567)	6.3 (.248)						
	3-4	3	1.25-L3			3.2 (.126)	8.0 (.315)	15.8 (.622)	7.0 (.276)						
	5-6	3.5	1.25-3.7			3.7 (.146)	5.5 (.217)	11.5 (.453)	4.0 (.157)						
	5-6	3.5	1.25-P3.5			3.7 (.146)	5.5 (.217)	13.9 (.547)	6.3 (.248)						
	5-6	3.5	1.25-M3	R1.25-3.5		3.7 (.146)	6.6 (.260)	14.4 (.567)	6.3 (.248)						
	5-6	3.5	1.25-L3.7			3.7 (.146)	8.0 (.315)	15.8 (.622)	7.0 (.276)						
	8	4	1.25-M4			4.3 (.169)	6.6 (.260)	14.4 (.567)	6.3 (.248)						
	8	4	1.25-4	R1.25-4		4.3 (.169)	8.0 (.315)	15.8 (.622)	7.0 (.276)						
	8	4	1.25-4NS			4.3 (.169)	9.0 (.354)	20.4 (.803)	11.1 (.437)						
	10	5	1.25-5	R1.25-5		5.3 (.209)	8.0 (.315)	15.8 (.622)	7.0 (.276)						
	10	5	1.25-5NS			5.3 (.209)	9.0 (.354)	20.4 (.803)	11.1 (.437)						
	10	5	1.25-L5			5.3 (.209)	11.6 (.457)	21.7 (.854)	11.1 (.437)						
1/4	6	1.25-6		6.4 (.252)	11.6 (.457)	21.7 (.854)	11.1 (.437)								
5/16	8	1.25-8		8.4 (.331)	11.6 (.457)	21.7 (.854)	11.1 (.437)								
3/8	10	1.25-10		10.5 (.413)	13.6 (.535)	25.5 (1.004)	13.9 (.547)								
1/2	12	1.25-12		13.0 (.512)	19.0 (.748)	31.0 (1.220)	16.7 (.657)								
16 to 14 (1.04 to 2.63)	1-2	2	2-S2			2.2 (.087)	6.4 (.252)	12.3 (.484)	4.3 (.169)	4.8 (.189)	4.1 (.161)	2.3 (.091)	0.8 (.031)	YHT-2210 YA-1 YA-2 YA-4 BCT-0514L	1,000
	3-4	3	2-MS3			3.2 (.126)	5.5 (.217)	13.2 (.520)	5.6 (.220)						
	3-4	3	2-S3.3			3.2 (.126)	6.4 (.252)	12.3 (.484)	4.3 (.169)						
	3-4	3	2-M3.3			3.2 (.126)	6.6 (.260)	14.4 (.567)	6.3 (.248)						
	3-4	3	2-3			3.2 (.126)	8.5 (.335)	16.8 (.661)	7.8 (.307)						
	5-6	3.5	2-MS3.5			3.7 (.146)	5.5 (.217)	13.9 (.547)	6.3 (.248)						
	5-6	3.5	2-S3			3.7 (.146)	6.4 (.252)	12.3 (.484)	4.3 (.169)						
	5-6	3.5	2-M3	R2-3.5		3.7 (.146)	6.6 (.260)	14.4 (.567)	6.3 (.248)						
	5-6	3.5	2-P3.5			3.7 (.146)	7.0 (.276)	16.0 (.630)	7.7 (.303)						
	5-6	3.5	2-3.7			3.7 (.146)	8.5 (.335)	16.8 (.661)	7.8 (.307)						
	8	4	2-M4			4.3 (.169)	6.6 (.260)	14.4 (.567)	6.3 (.248)						
	8	4	2-P4			4.3 (.169)	7.0 (.276)	16.0 (.630)	7.7 (.303)						
	8	4	2-4	R2-4		4.3 (.169)	8.5 (.335)	16.8 (.661)	7.8 (.307)						
	8	4	2-4NS			4.3 (.169)	9.0 (.354)	20.3 (.799)	11.0 (.433)						
	10	5	2-M5			5.3 (.209)	8.5 (.335)	16.8 (.661)	7.8 (.307)						
10	5	2-5NS		5.3 (.209)	9.0 (.354)	20.3 (.799)	11.0 (.433)								
10	5	2-5	R2-5	5.3 (.209)	9.5 (.374)	16.8 (.661)	7.3 (.287)								
1/4	6	2-6	R2-6	6.4 (.252)	12.0 (.472)	21.8 (.858)	11.0 (.433)								
5/16	8	2-8	R2-8	8.4 (.331)	12.0 (.472)	21.8 (.858)	11.0 (.433)								

Note: 1) Products with the JIS mark conform to JIS C2805.

2) The part numbers indicated in the above table are for products with a brazed seam.

When ordering products with a nominal size of 0.5 to 5.5 with a butted seam, add the prefix "WS" to the part number (ex. 2-4 → **WS2-4**).

3) Delivery lead times may vary depending on the product. Contact JST for details.

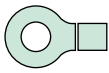

RING TONGUE (R type) Non-insulated

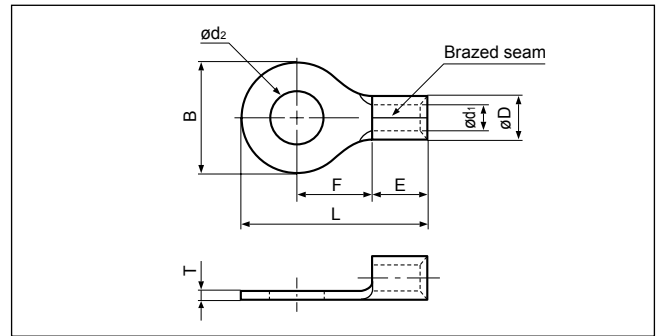
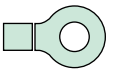

Applicable Wire AWG#(mm ²)	Stud size		Part No.		Standard	Dimensions mm (in.)								Tool No.	Qty/box
	American	Metric	JST	JIS		ϕd_2	B	L	F	E	ϕD	ϕd_1	T		
16 to 14 (1.04 to 2.63)	3/8	10	2-10		UL JIS	10.5 (.413)	13.6 (.535)	25.5(1.004)	13.9 (.547)	4.8 (.189)	4.1 (.161)	2.3 (.091)	0.8 (.031)	YHT-2210 YA-1 YA-2 YA-4 BCT-0514L	1,000
	1/2	12	2-12			13.0 (.512)	19.0 (.748)	31.0(1.220)	16.7 (.675)						500
	1/2	14	2-14			15.0 (.591)	27.0(1.063)	39.5(1.555)	21.2 (.835)						
	5/8	16	2-16			17.0 (.669)	27.0(1.063)	39.5(1.555)	21.2 (.835)						
	3/4	20	2-20			21.0 (.827)	27.0(1.063)	39.5(1.555)	21.2 (.835)						
14 to 12 (3.5)	3-4	3	3.5-R3		UL JIS	3.2 (.126)	8.0 (.315)	17.8 (.707)	9.0 (.354)	4.8 (.189)	4.8 (.189)	2.7 (.106)	1.0 (.039)	YHT-2210 (Dies mark. 5) BCT-0514L	1,000
	8	4	3.5-R4			4.3 (.169)	8.0 (.315)	17.8 (.707)	9.0 (.354)						
	8	4	3.5-4			4.3 (.169)	10.3 (.406)	18.6 (.732)	8.6 (.339)						
	10	5	3.5-R5			5.3 (.209)	8.0 (.315)	17.8 (.707)	9.0 (.354)						
	10	5	3.5-5			5.3 (.209)	10.3 (.406)	18.6 (.732)	8.6 (.339)						
	1/4	6	3.5-6			6.4 (.252)	10.3 (.406)	18.6 (.732)	8.6 (.339)						
12 to 10 (2.63 to 6.64)	3-4	3	5.5-S3.3		UL JIS	3.2 (.126)	7.2 (.283)	15.7 (.618)	5.9 (.232)	5.6 (.220)	3.4 (.134)	1.0 (.039)	YHT-2210 YA-1 YA-2 YA-4 BCT-0514L	500	
	3-4	3	5.5-3			3.2 (.126)	9.5 (.374)	19.8 (.780)	8.3 (.327)					6.8 (.268)	
	5-6	3.5	5.5-S3			3.7 (.146)	7.2 (.283)	15.7 (.618)	5.9 (.232)					6.2 (.244)	
	5-6	3.5	5.5-3.7			3.7 (.146)	9.5 (.374)	19.8 (.780)	8.3 (.327)					6.8 (.268)	
	8	4	5.5-S4		UL JIS	4.3 (.169)	7.2 (.283)	15.7 (.618)	5.9 (.232)	6.8 (.268)	3.4 (.134)	1.0 (.039)		1,000	
	8	4	5.5-4NS			4.3 (.169)	8.0 (.315)	19.1 (.752)	8.3 (.327)						
	8	4	5.5-4	R5.5-4	UL JIS JIS	4.3 (.169)	9.5 (.374)	19.8 (.780)	8.3 (.327)						
	10	5	5.5-5NS		UL JIS	5.3 (.209)	8.0 (.315)	19.1 (.752)	8.3 (.327)						
	10	5	5.5-5	R5.5-5	UL JIS JIS	5.3 (.209)	9.5 (.374)	19.8 (.780)	8.3 (.327)						
	10	5	5.5-S5		UL JIS	5.3 (.209)	13.2 (.520)	22.4 (.882)	9.0 (.354)						
	1/4	6	5.5-6NS		UL JIS	6.4 (.252)	9.0 (.354)	24.3 (.957)	13.0 (.512)						
	1/4	6	5.5-6	R5.5-6	UL JIS JIS	6.4 (.252)	12.0 (.472)	25.8(1.016)	13.0 (.512)						
	1/4	6	5.5-S6		UL JIS	6.4 (.252)	13.2 (.520)	22.4 (.882)	9.0 (.354)						
	1/4	6	5.5-L6			6.4 (.252)	15.0 (.591)	28.0(1.102)	13.7 (.539)						
	5/16	8	5.5-S8		UL JIS	8.4 (.331)	13.2 (.520)	22.4 (.882)	9.0 (.354)						
	5/16	8	5.5-8	R5.5-8		UL JIS JIS	8.4 (.331)	15.0 (.591)	28.0(1.102)					13.7 (.539)	
	3/8	9	5.5-9		UL JIS	9.8 (.386)	15.0 (.591)	28.0(1.102)	13.7 (.539)						
	3/8	10	5.5-10	R5.5-10	UL JIS JIS	10.5 (.413)	15.0 (.591)	28.0(1.102)	13.7 (.539)						
	1/2	12	5.5-12		UL JIS	13.0 (.512)	19.2 (.756)	32.4(1.276)	16.0 (.630)						
	1/2	14	5.5-14			15.0 (.591)	32.0(1.260)	48.1(1.894)	25.3 (.996)						
5/8	16	5.5-16		17.0 (.669)		32.0(1.260)	48.1(1.894)	25.3 (.996)							
11/16	18	5.5-18		19.0 (.748)		32.0(1.260)	48.1(1.894)	25.3 (.996)							
3/4	20	5.5-20		UL JIS	21.0 (.827)	32.0(1.260)	48.1(1.894)	25.3 (.996)							

Note: 1) Products with the JIS mark (JIS) conform to JIS C2805.

2) The part numbers indicated in the above table are for products with a braided seam.

When ordering products with a nominal size of 0.5 to 5.5 with a butted seam, add the prefix "WS" to the part number (ex. 5.5-4 → **WS5.5-4**).

3) Delivery lead times may vary depending on the product. Contact JST for details.

Solderless terminals

RING TONGUE (R type) Non-insulated

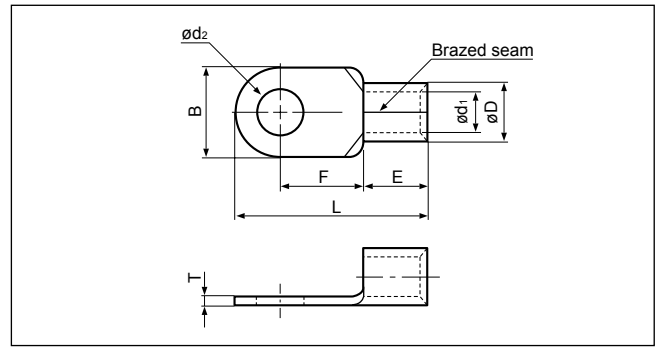

Applicable Wire AWG#(mm ²)	Stud size		Part No.		Standard	Dimensions mm (in.)							Tool No.	Qty/box		
	American	Metric	JST	JIS		ødz	B	L	F	E	øD	ød1			T	
8 (6.64 to 10.52)	8	4	8-NK4			4.3 (.169)	9.0 (.354)	16.5 (.650)	5.8 (.228)	6.2 (.244)	7.1 (.280)	4.5 (.177)	1.2 (.047)	YA-4 YPT-60N YF-1 YET-60-1 E-4 EP-1 (Note 2)	500	
	8	4	8-4NS			4.3 (.169)	8.0 (.315)	21.8 (.858)	9.3 (.366)	8.5 (.335)				YHT-8S YA-4, YA-5 YPT-60N YPT-150-1 BCT-0514L BCT-860L BCT-8150L YF-1 YET-60-1 E-4 YET-150-1 EP-1 YET-60-1	1,000	
	8	4	8-4			4.3 (.169)	12.0 (.472)	23.8 (.937)	9.3 (.366)	8.5 (.335)				YA-4 YPT-60N YF-1 YET-60-1 E-4 EP-1 (Note 2)	500	
	10	5	8-NK5			5.3 (.209)	9.0 (.354)	16.5 (.650)	5.8 (.228)	6.2 (.244)				8.5 (.335)	YHT-8S YA-4 YA-5 YPT-60N YPT-150-1 BCT-0514L BCT-860L BCT-8150L YF-1 YET-60-1 E-4 YET-150-1 EP-1 YET-60-1	1,000
	10	5	8-5NS			5.3 (.209)	9.0 (.354)	22.3 (.878)	9.3 (.366)	500						
	10	5	8-5	R8-5		5.3 (.209)	12.0 (.472)	23.8 (.937)	9.3 (.366)	1,000						
	10	5	8-L5NS			5.3 (.209)	9.0 (.354)	26.8(1.055)	13.8 (.543)	500						
	10	5	8-L5			5.3 (.209)	15.0 (.591)	29.8(1.173)	13.8 (.543)	500						
	1/4	6	8-6NS			6.4 (.252)	9.6 (.378)	22.6 (.890)	9.3 (.366)	1,000						
	1/4	6	8-6	R8-6		6.4 (.252)	12.0 (.472)	23.8 (.937)	9.3 (.366)	500						
	1/4	6	8-L6			6.4 (.252)	15.0 (.591)	29.8(1.173)	13.8 (.543)	1,000						
	5/16	8	8-8NS			8.4 (.331)	11.5 (.453)	28.1(1.106)	13.8 (.543)	500						
	5/16	8	8-8	R8-8		8.4 (.331)	15.0 (.591)	29.8(1.173)	13.8 (.543)	1,000						
	3/8	10	8-10	R8-10		10.5 (.413)	15.0 (.591)	29.8(1.173)	13.8 (.543)	500						
	3/8	10	8-L10			10.5 (.413)	20.0 (.787)	33.5(1.319)	15.0 (.591)	200						
	7/16	11	8-11			11.5 (.453)	20.0 (.787)	33.5(1.319)	15.0 (.591)							
	1/2	12	8-12			13.0 (.512)	20.0 (.787)	33.5(1.319)	15.0 (.591)							
	1/2	14	8-14			15.0 (.591)	31.6(1.244)	50.0(1.969)	25.7(1.012)							
5/8	16	8-16			17.0 (.669)	31.6(1.244)	50.0(1.969)	25.7(1.012)								
11/16	18	8-18			19.0 (.748)	31.6(1.244)	50.0(1.969)	25.7(1.012)								
3/4	20	8-20			21.0 (.827)	31.6(1.244)	50.0(1.969)	25.7(1.012)								

- Note: 1) Products with the JIS mark conform to JIS C2805.
 2) Please use the die AD-901S for the pneumatic tool YA-4, and the die 8NK-6 for the hydraulic tools YPT-60N/YET-60-1.
 3) Delivery lead times may vary depending on the product. Contact JST for details.

Solderless terminals

RING TONGUE (R type) Non-insulated

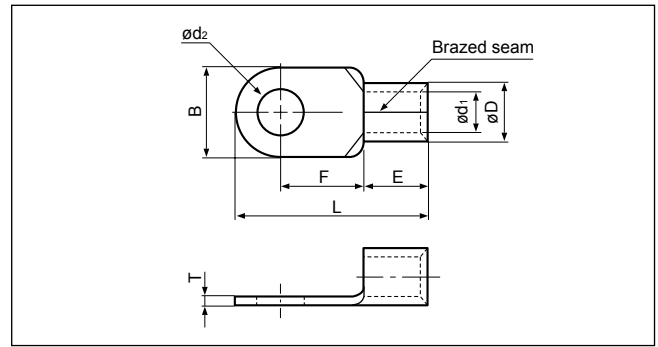

Applicable Wire AWG#(mm ²)	Stud size		Part No.		Standard	Dimensions mm (in.)							Tool No.	Qty/box	
	American	Metric	JST	JIS		ød2	B	L	F	E	øD	ød1			T
6 (10.52 to 16.78)	8	4	14-4			4.3 (.169)	12.0 (.472)	29.8(1.173)	13.3 (.524)	10.5 (.413)	9.0 (.354)	5.8 (.228)	1.5 (.059)	YA-4 YA-5 YPT-60N BCT-0514L BCT-8150L BCT-860L BCT-8150L YF-1 YET-60-1 E-4 YET-150-1 EP-1 YET-60-1	200
	8	4	14-NK4		UL SF	4.3 (.169)	12.2 (.480)	23.0 (.906)	7.7 (.303)	9.2 (.362)					
	10	5	14-5NS			5.3 (.209)	9.0 (.354)	28.3(1.114)	13.3 (.524)	10.5 (.413)					
	10	5		R14-5	UL SF JIS	5.3 (.209)	12.0 (.472)	29.8(1.173)	13.3 (.524)	10.5 (.413)					
	10	5	14-NK5		UL SF	5.3 (.209)	12.2 (.480)	23.0 (.906)	7.7 (.303)	9.2 (.362)					
	1/4	6	14-6NS			6.4 (.252)	9.6 (.378)	28.6(1.126)	13.3 (.524)	10.5 (.413)					
	1/4	6	14-6	R14-6	UL SF JIS	6.4 (.252)	12.0 (.472)	29.8(1.173)	13.3 (.524)	10.5 (.413)					
	1/4	6	14-L6			6.4 (.252)	16.0 (.630)	32.8(1.291)	14.5 (.571)	10.5 (.413)					
	5/16	8	14-8NS		UL SF	8.4 (.331)	11.5 (.453)	30.8(1.213)	14.5 (.571)	10.5 (.413)					
	5/16	8	14-S8			8.4 (.331)	12.0 (.472)	31.0(1.220)	14.5 (.571)	10.5 (.413)					
	5/16	8	14-8	R14-8	UL SF JIS	8.4 (.331)	16.0 (.630)	32.8(1.291)	14.5 (.571)	10.5 (.413)					
	3/8	9	14-9		UL SF	9.8 (.386)	16.0 (.630)	32.8(1.291)	14.5 (.571)	10.5 (.413)					
	3/8	10	14-10	R14-10	UL SF JIS	10.5 (.413)	16.0 (.630)	32.8(1.291)	14.5 (.571)	10.5 (.413)					
	3/8	10	14-L10		UL SF	10.5 (.413)	22.0 (.866)	41.0(1.614)	19.5 (.739)	10.5 (.413)					
	7/16	11	14-11		UL SF	11.5 (.453)	22.0 (.866)	41.0(1.614)	19.5 (.739)	10.5 (.413)					
	1/2	12	14-12	R14-12	UL SF JIS	13.0 (.512)	22.0 (.866)	41.0(1.614)	19.5 (.739)	10.5 (.413)					
	1/2	14	14-14	R14-14	UL SF JIS	15.0 (.591)	30.0(1.181)	49.0(1.929)	23.5 (.925)	10.5 (.413)					
	5/8	16	14-16			17.0 (.669)	31.6(1.244)	51.5(2.028)	25.2 (.992)	10.5 (.413)					
11/16	18	14-18		UL SF	19.0 (.748)	31.6(1.244)	51.5(2.028)	25.2 (.992)	10.5 (.413)						
3/4	20	14-20			21.0 (.827)	31.6(1.244)	51.5(2.028)	25.2 (.992)	10.5 (.413)						
4 (16.78 to 26.66)	10	5	22-5NS			5.3 (.209)	9.5 (.374)	28.7(1.130)	12.0 (.472)	12.0 (.472)	11.5 (.453)	7.7 (.303)	1.8 (.071)	YA-5 YPT-60N YPT-150-1 BCT-860L BCT-8150L YF-1 YET-60-1 E-4 YET-150-1 EP-1 YET-60-1	100
	10	5	22-S5		UL SF	5.3 (.209)	12.0 (.472)	30.0(1.181)	12.0 (.472)						
	10	5	22-5			5.3 (.209)	16.5 (.650)	33.7(1.327)	13.5 (.531)						
	1/4	6	22-S6			6.4 (.252)	12.0 (.472)	30.0(1.181)	12.0 (.472)						
	1/4	6	22-6	R22-6	UL SF JIS	6.4 (.252)	16.5 (.650)	33.7(1.327)	13.5 (.531)						
	5/16	8	22-S8		UL SF	8.4 (.331)	12.0 (.427)	30.0(1.181)	12.0 (.472)						
	5/16	8	22-8	R22-8	UL SF JIS	8.4 (.331)	16.5 (.650)	33.7(1.327)	13.5 (.531)						
	3/8	9	22-9		UL SF	9.8 (.386)	17.5 (.689)	36.7(1.445)	16.0 (.630)						
	3/8	10	22-S10		UL SF	10.5 (.413)	16.5 (.650)	33.7(1.327)	13.5 (.531)						
	3/8	10	22-10	R22-10	UL SF JIS	10.5 (.413)	17.5 (.689)	36.7(1.445)	16.0 (.630)						
	7/16	11	22-11		UL SF	11.5 (.453)	22.0 (.866)	42.5(1.673)	19.5 (.768)						
	1/2	12	22-12	R22-12	UL SF JIS	13.0 (.512)	22.0 (.866)	42.5(1.673)	19.5 (.768)						
	1/2	14		R22-14	UL SF JIS	15.0 (.591)	30.0(1.181)	51.5(2.038)	24.5 (.965)						
	5/8	16	22-16			17.0 (.669)	30.0(1.181)	51.5(2.028)	24.5 (.965)						
11/16	18	22-18		UL SF	19.0 (.748)	30.0(1.181)	51.5(2.028)	24.5 (.965)							
3/4	20	22-20			21.0 (.827)	30.0(1.181)	51.5(2.028)	24.5 (.965)							

Note:1) Products with the JIS mark (JIS) conform to JIS C2805.

2) Delivery lead times may vary depending on the product. Contact JST for details.

Solderless terminals

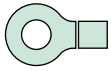

RING TONGUE (R type) Non-insulated

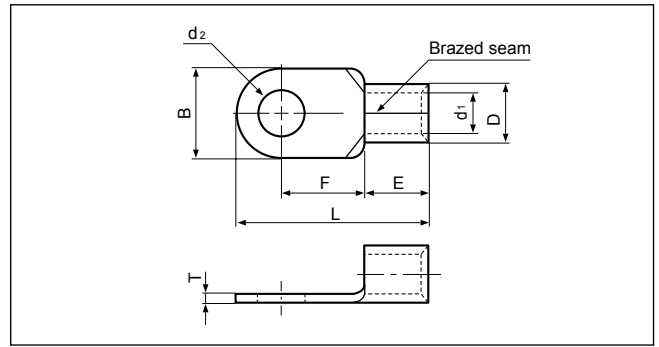

Applicable Wire AWG#(mm ²)	Stud size		Part No.		Standard	Dimensions mm (in.)								Tool No.	Qty/box
	American	Metric	JST	JIS		ød ₂	B	L	F	E	øD	ød ₁	T		
2 (26.66 to 42.42)	10	5	38-S5		UL LF0001	5.3 (.209)	15.5 (.610)	38.0(1.496)	16.0 (.630)	14.0 (.551)	13.3 (.524)	9.4 (.370)	1.8 (.071)	YA-5 YPT-60N YPT-150-1 BCT-860L BCT-8150L YF-1 E-4 EP-1	100
	10	5	38-5			5.3 (.209)	22.0 (.866)	42.7(1.681)	17.7 (.697)						
	1/4	6	38-S6			6.4 (.252)	15.5 (.610)	38.0(1.496)	16.0 (.630)						
	1/4	6	38-6			6.4 (.252)	22.0 (.866)	42.7(1.681)	17.7 (.697)						
	5/16	8	38-S8			8.4 (.331)	15.5 (.610)	38.0(1.496)	16.0 (.630)						
	5/16	8	38-8	R38-8		UL LF0001	8.4 (.331)	22.0 (.866)	42.7(1.681)						
	5/16	8	38-L8		UL LF0001	8.4 (.331)	30.0(1.181)	52.5(2.067)	23.5 (.925)						
	3/8	9	38-9		UL LF0001	9.8 (.386)	22.0 (.866)	42.7(1.681)	17.7 (.697)						
	3/8	10	38-S10		UL LF0001	10.5 (.413)	15.5 (.610)	38.0(1.496)	16.0 (.630)						
	3/8	10	38-10	R38-10	UL LF0001	10.5 (.413)	22.0 (.866)	42.7(1.681)	17.7 (.697)						
	3/8	10	38-L10		UL LF0001	10.5 (.413)	30.0(1.181)	52.5(2.067)	23.5 (.925)						
	7/16	11	38-11		UL LF0001	11.5 (.453)	22.0 (.866)	42.7(1.681)	17.7 (.697)						
	1/2	12	38-12	R38-12	UL LF0001	13.0 (.512)	22.0 (.866)	42.7(1.681)	17.7 (.697)						
	1/2	14	38-14	R38-14	UL LF0001	15.0 (.591)	30.0(1.181)	52.5(2.067)	23.5 (.925)						
5/8	16	38-16		UL LF0001	17.0 (.669)	30.0(1.181)	52.5(2.067)	23.5 (.925)							
11/16	18	38-18		UL LF0001	19.0 (.748)	30.0(1.181)	52.5(2.067)	23.5 (.925)							
3/4	20	38-20		UL LF0001	21.0 (.827)	30.0(1.181)	52.5(2.067)	23.5 (.925)							
1/0 (42.42 to 60.57)	1/4	6	60-S6		UL LF0001	6.4 (.252)	16.0 (.630)	46.7(1.839)	20.7 (.815)	18.0 (.709)	15.5 (.610)	11.4 (.449)	2.0 (.079)	YA-5 YPT-60N YPT-150-1 BCT-860L BCT-8150L YF-1 E-4 EP-1	50
	1/4	6	60-6		6.4 (.252)	22.0 (.866)	49.7(1.957)	20.7 (.815)							
	5/16	8	60-S8		8.4 (.331)	16.0 (.630)	46.7(1.839)	20.7 (.815)							
	5/16	8	60-8	R60-8	UL LF0001	8.4 (.331)	22.0 (.866)	49.7(1.957)	20.7 (.815)						
	3/8	9	60-9		UL LF0001	9.8 (.386)	22.0 (.866)	49.7(1.957)	20.7 (.815)						
	3/8	10	60-S10		UL LF0001	10.5 (.413)	16.0 (.630)	46.7(1.839)	20.7 (.815)						
	3/8	10	60-10	R60-10	UL LF0001	10.5 (.413)	22.0 (.866)	49.7(1.957)	20.7 (.815)						
	7/16	11	60-11		UL LF0001	11.5 (.453)	22.0 (.866)	49.7(1.957)	20.7 (.815)						
	1/2	12	60-12	R60-12	UL LF0001	13.0 (.512)	22.0 (.866)	49.7(1.957)	20.7 (.815)						
	1/2	14	60-14	R60-14	UL LF0001	15.0 (.591)	32.0(1.260)	57.5(2.264)	23.5 (.925)						
	5/8	16	60-16		UL LF0001	17.0 (.669)	32.0(1.260)	57.5(2.264)	23.5 (.925)						
	11/16	18	60-18		UL LF0001	19.0 (.748)	32.0(1.260)	57.5(2.264)	23.5 (.925)						
	3/4	20	60-20		UL LF0001	21.0 (.827)	32.0(1.260)	57.5(2.264)	23.5 (.925)						
7/8	22	60-22		UL LF0001	23.0 (.906)	32.0(1.260)	57.5(2.264)	23.5 (.925)							
2/0 (60.57 to 76.28)	1/4	6	70-6		UL LF0001	6.4 (.252)	24.0 (.945)	51.0(2.008)	20.0 (.787)	19.0 (.748)	17.5 (.689)	13.3 (.524)	2.0 (.079)	YPT-150-1 BCT-8150L YF-1 E-4 EP-1	25
	5/16	8	70-8			8.4 (.331)	24.0 (.945)	51.0(2.008)	20.0 (.787)						
	3/8	9	70-9			9.8 (.386)	24.0 (.945)	51.0(2.008)	20.0 (.787)						
	3/8	10	70-10			10.5 (.413)	24.0 (.945)	51.0(2.008)	20.0 (.787)						
	7/16	11	70-11			11.5 (.453)	24.0 (.945)	51.0(2.008)	20.0 (.787)						
	1/2	12	70-12			13.0 (.512)	24.0 (.945)	51.0(2.008)	20.0 (.787)						
	1/2	14	70-14			15.0 (.591)	32.0(1.260)	61.0(2.402)	26.0(1.024)						
	5/8	16	70-16			17.0 (.669)	32.0(1.260)	61.0(2.402)	26.0(1.024)						
	11/16	18	70-18			19.0 (.748)	32.0(1.260)	61.0(2.402)	26.0(1.024)						
	3/4	20	70-20			21.0 (.827)	32.0(1.260)	61.0(2.402)	26.0(1.024)						
	7/8	22	70-22			23.0 (.906)	32.0(1.260)	61.0(2.402)	26.0(1.024)						

Note: 1) Products with the JIS mark (JIS) conform to JIS C2805.
 2) Part numbers containing "S0" do not have stud holes.
 3) Delivery lead times may vary depending on the product. Contact JST for details.

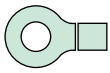

RING TONGUE (R type) Non-insulated

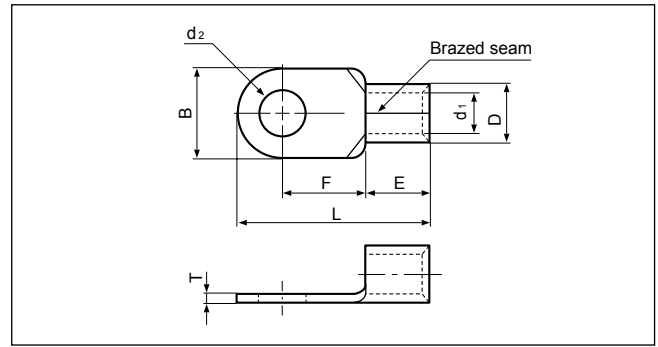
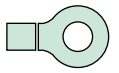

Applicable Wire AWG#(mm ²)	Stud size		Part No.		Standard	Dimensions mm (in.)								Tool No.	Qty/box
	American	Metric	JST	JIS		ød ₂	B	L	F	E	øD	ød ₁	T		
3/0 (76.28 to 96.3)	1/4	6	80-6		UL CSA SP	6.4 (.252)	27.0(1.063)	54.2(2.134)	20.7 (.815)	20.0 (.787)	19.5 (.768)	14.5 (.571)	2.3 (.091)	YPT-150-1 BCT-8150L YF-1 E-4 EP-1 YET-150-1 YF-1 E-4 YET-300-1 YET-300N	25
	5/16	8	80-8			8.4 (.331)	27.0(1.063)	54.2(2.134)	20.7 (.815)						
	5/16	8	80-L8			8.4 (.331)	32.0(1.260)	68.0(2.677)	32.0(1.260)						
	3/8	10	80-10			10.5 (.413)	27.0(1.063)	54.2(2.134)	20.7 (.815)						
	3/8	10	80-L10			10.5 (.413)	32.0(1.260)	68.0(2.677)	32.0(1.260)						
	7/16	11	80-11			11.5 (.453)	27.0(1.063)	54.2(2.134)	20.7 (.815)						
	1/2	12	80-12			13.0 (.512)	27.0(1.063)	54.2(2.134)	20.7 (.815)						
	1/2	12	80-L12			13.0 (.512)	32.0(1.260)	68.0(2.677)	32.0(1.260)						
	1/2	14	80-14			15.0 (.591)	32.0(1.260)	68.0(2.677)	32.0(1.260)						
	5/8	16	80-16			17.0 (.669)	32.0(1.260)	68.0(2.677)	32.0(1.260)						
	11/16	18	80-18			19.0 (.748)	32.0(1.260)	68.0(2.677)	32.0(1.260)						
	3/4	20	80-20			21.0 (.827)	32.0(1.260)	68.0(2.677)	32.0(1.260)						
	4/0 (96.3 to 117.2)	1/4	6	100-6			UL CSA SP JIS	6.4 (.252)	28.5(1.122)						
5/16		8	100-8		8.4 (.331)	28.5(1.122)		55.6(2.189)	20.4 (.803)						
5/16		8	100-L8		8.4 (.331)	32.0(1.260)		69.0(2.717)	32.0(1.260)						
3/8		9	100-9		9.8 (.386)	28.5(1.122)		55.6(2.189)	20.4 (.803)						
3/8		10	100-10	R100-10	10.5 (.413)	28.5(1.122)		55.6(2.189)	20.4 (.803)						
3/8		10	100-L10		10.5 (.413)	32.0(1.260)		69.0(2.717)	32.0(1.260)						
1/2		12	100-12	R100-12	13.0 (.512)	28.5(1.122)		55.6(2.189)	20.4 (.803)						
1/2		12	100-L12		13.0 (.512)	32.0(1.260)		69.0(2.717)	32.0(1.260)						
1/2		14	100-14	R100-14	15.0 (.591)	32.0(1.260)		69.0(2.717)	32.0(1.260)						
5/8		16	100-16	R100-16	17.0 (.669)	32.0(1.260)		69.0(2.717)	32.0(1.260)						
7/8	22	100-22		23.0 (.906)	32.0(1.260)	69.0(2.717)	32.0(1.260)								

Note: 1) Products with the JIS mark (JIS) conform to JIS C2805.
 2) Part numbers containing "S0" or "L0" do not have stud holes.

Solderless terminals

RING TONGUE (R type) Non-insulated

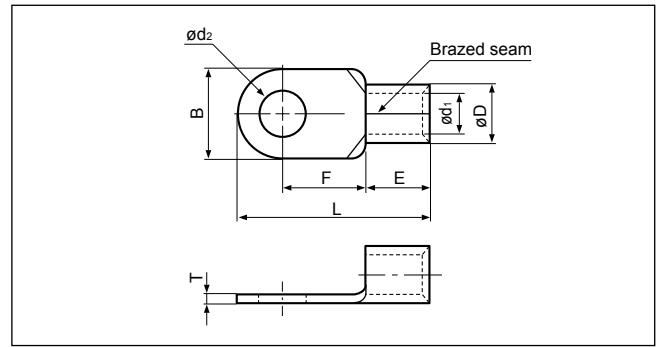

Applicable Wire AWG#(mm ²)	Stud size		Part No.	Standard	Dimensions mm (in.)								Tool No.	Qty/box
	American	Metric			ød2	B	L	F	E	øD	ød1	T		
250/300 (117.2 to 152.05)	-	-	150-L0		-	36.0(1.417)	81.0(3.189)	36.0(1.417)	27.0 (1.063)	26.5 (1.043)	19.5 (.768)	3.2 (.126)	YPT-150-1 BCT-8150L YF-1 E-4 YET-150-1 EP-1 YF-1 YET-300-1 E-4 YET-300N	20
	1/4	6	150-6	UL SF	6.4 (.252)	36.0(1.417)	66.0(2.600)	23.0 (.906)						
	5/16	8	150-8	UL SF	8.4 (.331)	36.0(1.417)	66.0(2.600)	23.0 (.906)						
	5/16	8	150-L8		8.4 (.331)	36.0(1.417)	81.0(3.189)	36.0(1.417)						
	3/8	10	R150-10	UL SF JIS	10.5 (.413)	36.0(1.417)	66.0(2.600)	21.0 (.827)						
	3/8	10	150-10	UL SF	10.5 (.413)	36.0(1.417)	66.0(2.600)	23.0 (.906)						
	3/8	10	150-L10	UL SF	10.5 (.413)	36.0(1.417)	81.0(3.189)	36.0(1.417)						
	7/16	11	150-11	UL SF	11.5 (.453)	36.0(1.417)	66.0(2.600)	23.0 (.906)						
	1/2	12	R150-12	UL SF JIS	13.0 (.512)	36.0(1.417)	66.0(2.600)	21.0 (.827)						
	1/2	12	150-12	UL SF	13.0 (.512)	36.0(1.417)	66.0(2.600)	23.0 (.906)						
	1/2	12	150-L12	UL SF	13.0 (.512)	36.0(1.417)	81.0(3.189)	36.0(1.417)						
	1/2	14	R150-14	UL SF JIS	15.0 (.591)	36.0(1.417)	68.0(2.677)	23.0 (.906)						
	5/8	16	150-16	UL SF	17.0 (.669)	36.0(1.417)	66.0(2.600)	23.0 (.906)						
	5/8	16	R150-16	UL SF JIS	17.0 (.669)	36.0(1.417)	68.0(2.677)	23.0 (.906)						
	5/8	16	150-L16	UL SF	17.0 (.669)	36.0(1.417)	81.0(3.189)	36.0(1.417)						
	11/16	18	R150-18	UL SF JIS	19.0 (.748)	36.0(1.417)	81.0(3.189)	36.0(1.417)						
	3/4	20	R150-20	UL SF JIS	21.0 (.827)	36.0(1.417)	81.0(3.189)	36.0(1.417)						
	350 (152.05 to 192.60)	7/8	22	150-22	UL SF	23.0 (.906)	36.0(1.417)	81.0(3.189)						
15/16		24	150-24	UL SF	25.0 (.984)	36.0(1.417)	81.0(3.189)	36.0(1.417)						
1		27	150-27	UL SF	28.0(1.102)	36.0(1.417)	81.0(3.189)	36.0(1.417)						
5/16		8	180-8		8.4 (.331)	38.5(1.516)	69.0(2.717)	24.5 (.965)						
5/16		8	180-L8		8.4 (.331)	38.5(1.516)	86.8(3.417)	39.0(1.535)						
3/8		10	180-10		10.5 (.413)	38.5(1.516)	69.0(2.717)	24.5 (.965)						
3/8		10	180-L10		10.5 (.413)	38.5(1.516)	86.8(3.417)	39.0(1.535)						
7/16		11	180-11		1.5 (.453)	38.5(1.516)	69.0(2.717)	24.5 (.965)						
1/2		12	180-12		13.0 (.512)	38.5(1.516)	69.0(2.717)	24.5 (.965)						
1/2		12	180-L12	UL SF	13.0 (.512)	38.5(1.516)	86.8(3.417)	39.0(1.535)						
1/2		14	180-14	UL SF	15.0 (.591)	38.5(1.516)	69.0(2.717)	24.5 (.965)						
5/8		16	180-L16	UL SF	17.0 (.669)	38.5(1.516)	86.8(3.417)	39.0(1.535)						
5/8		16	180-16	UL SF	17.0 (.669)	38.5(1.516)	69.0(2.717)	24.5 (.965)						
11/16		18	180-18	UL SF	19.0 (.748)	38.5(1.516)	86.8(3.417)	39.0(1.535)						
3/4	20	180-20	UL SF	21.0 (.827)	38.5(1.516)	86.8(3.417)	39.0(1.535)							
7/8	22	180-22	UL SF	23.0 (.906)	38.5(1.516)	86.8(3.417)	39.0(1.535)							
15/16	24	180-24	UL SF	25.0 (.984)	38.5(1.516)	86.8(3.417)	39.0(1.535)							
1	27	180-27	UL SF	28.0 (1.102)	38.5(1.516)	86.8(3.417)	39.0(1.535)							

Note: 1) Products with the JIS mark conform to JIS C2805.
 2) Part numbers containing "S0" or "L0" do not have stud holes.
 3) Delivery lead times may vary depending on the product. Contact JST for details.



RING TONGUE (R type) Non-insulated

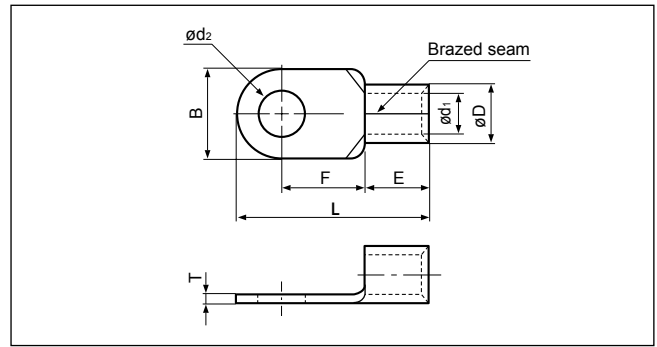

Applicable Wire AWG#(mm ²)	Stud size		Part No.	Standard	Dimensions mm (in.)							Tool No.	Qty/box	
	American	Metric			ϕd_2	B	L	F	E	ϕD	ϕd_1			T
400 (192.60 to 242.27)	-	-	200-L0		-	44.0(1.732)	91.0(3.583)	37.5(1.476)	31.5 (1.240)	32.7 (1.287)	24.0 (.945)	4.0 (.157)	YF-1 YET-300-1 E-4 YET-300N	10
	12/16	8	200-8		8.4 (.331)	44.0(1.732)	72.0(2.835)	24.5 (.965)						
	5/16	8	200-L8		8.4 (.331)	44.0(1.732)	72.0(2.835)	24.5 (.965)						
	3/8	10	200-10	UL SF	10.5 (.413)	44.0(1.732)	72.0(2.835)	24.5 (.965)						
	3/8	10	200-L10		10.5 (.413)	44.0(1.732)	91.0(3.583)	37.5(1.476)						
	7/16	11	200-11		11.5 (.453)	44.0(1.732)	72.0(2.835)	24.5 (.965)						
	1/2	12	200-12		13.0 (.512)	44.0(1.732)	72.0(2.835)	24.5 (.965)						
	1/2	12	R200-12	UL SF JIS	13.0 (.512)	44.0(1.732)	78.0(3.071)	24.5 (.965)						
	1/2	12	200-L12		13.0 (.512)	44.0(1.732)	91.0(3.583)	37.5(1.476)						
	1/2	14	200-14	UL SF	15.0 (.591)	44.0(1.732)	72.0(2.835)	24.5 (.965)						
	1/2	14	R200-14	UL SF JIS	15.0 (.591)	44.0(1.732)	78.0(3.071)	24.5 (.965)						
	5/8	16	200-16	UL SF	17.0 (.669)	44.0(1.732)	72.0(2.835)	24.5 (.965)						
	5/8	16	R200-16	UL SF JIS	17.0 (.669)	44.0(1.732)	78.0(3.071)	24.5 (.965)						
	5/8	16	200-L16	UL SF	17.0 (.669)	44.0(1.732)	91.0(3.583)	37.5(1.476)						
	11/16	18	R200-18		19.0 (.748)	44.0(1.732)	91.0(3.583)	37.5(1.476)						
	3/4	20	R200-20		21.0 (.827)	44.0(1.732)	91.0(3.583)	37.5(1.476)						
	7/8	22	R200-22	UL SF JIS	23.0 (.906)	44.0(1.732)	91.0(3.583)	37.5(1.476)						
	15/16	24	R200-24		25.0 (.984)	44.0(1.732)	91.0(3.583)	37.5(1.476)						
1	27	R200-27		28.0(1.102)	44.0(1.732)	91.0(3.583)	37.5(1.476)							
N.A. (250)	1/2	12	250-12		13.0 (.512)	44.0(1.732)	78.0(3.071)	24.5 (.965)	31.5 (1.240)	35.6 (1.402)	26.0 (1.024)	4.5 (.177)	YF-1 YET-300-1 E-4 YET-300N	
	1/2	14	250-14		15.0 (.591)									
	5/8	16	250-16		17.0 (.669)									
600/650 (242.27 to 325)	-	-	325-L0		-	50.5(1.988)	105.7(4.161)	45.0(1.772)	35.5 (1.398)	37.6 (1.480)	28.0 (1.102)	4.5 (.177)	YF-1 YET-300-1 E-4 YET-300N	5
	12/16	8	325-8		8.4 (.331)	50.5(1.988)	88.0(3.465)	33.5(1.319)						
	5/16	8	325-L8		8.4 (.331)	50.5(1.988)	105.7(4.161)	45.0(1.772)						
	3/8	10	325-10		10.5 (.413)	50.5(1.988)	88.0(3.465)	33.5(1.319)						
	3/8	10	325-L10		10.5 (.413)	50.5(1.988)	105.7(4.161)	45.0(1.772)						
	7/16	11	325-11	UL SF	11.5 (.453)	50.5(1.988)	88.0(3.465)	33.5(1.319)						
	1/2	12	325-12		13.0 (.512)	50.5(1.988)	88.0(3.465)	33.5(1.319)						
	1/2	12	325-L12		13.0 (.512)	50.5(1.988)	105.7(4.161)	45.0(1.772)						
	1/2	14	325-14		15.0 (.591)	50.5(1.988)	88.0(3.465)	33.5(1.319)						
	5/8	16	325-16		17.0 (.669)	50.5(1.988)	88.0(3.465)	33.5(1.319)						
	5/8	16	R325-16	UL SF JIS	17.0 (.669)	50.5(1.988)	94.2(3.709)	33.5(1.319)						
	5/8	16	325-L16		17.0 (.669)	50.5(1.988)	105.7(4.161)	45.0(1.772)						
	11/16	18	325-M18	UL SF	19.0 (.748)	50.5(1.988)	94.2(3.709)	33.5(1.319)						
	11/16	18	R325-18		19.0 (.748)	50.5(1.988)	105.7(4.161)	45.0(1.772)						
	3/4	20	R325-20		21.0 (.827)	50.5(1.988)	105.7(4.161)	45.0(1.772)						
	7/8	22	R325-22	UL SF JIS	23.0 (.906)	50.5(1.988)	105.7(4.161)	45.0(1.772)						
	15/16	24	R325-24		25.0 (.984)	50.5(1.988)	105.7(4.161)	45.0(1.772)						
	1	27	R325-27		28.0(1.102)	50.5(1.988)	105.7(4.161)	45.0(1.772)						

Note: 1) Products with the JIS mark conform to JIS C2805.
 2) Part numbers containing "S0" or "L0" do not have stud holes.
 3) Delivery lead times may vary depending on the product. Contact JST for details.

单击下面可查看定价，库存，交付和生命周期等信息

[>>JST\(杰世腾\)](#)