



APPROVAL SHEET

Approval Specification	Customer' s Approval Certificate
TO:	Checked & Approved by:
Part No.:	Date:
Customer' s Part No.:	Please return this copy as a certification of your approval

KaiTuo Crystal Technology (Zhongshan) Co., Ltd.

Tel: +86-760-22556637

Fax: +86-760-22556637

E-mail: sales@kt-saw.com

QQ: 88210849

Website: <http://www.kt-saw.com>

Add: Building 17, Zhongnan Hi Tech Zhihui Valley, Banfu Town, Zhongshan City

Part No.	: R433T
Pages	: 6
Date	: 2023/3/1
Revision	: 1.0

Repared by:	<i>liule</i>
Checked by:	<i>55</i>
Approved by:	<i>14G</i>

1.Features

- 1-port Resonator
- Ceramic Package for **Surface Mounted Technology (SMT)**
- **RoHS** compatible
- Package size 6.0*2.6*1.6mm³
- Package Code MEMS2660
- **Electrostatic Sensitive Device(ESD)**

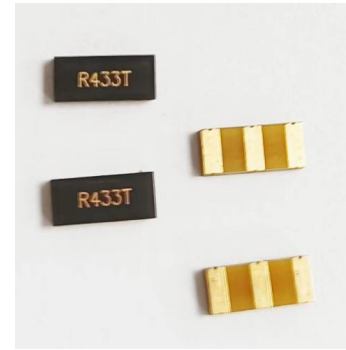

Package Dimensions (MEMS2660)

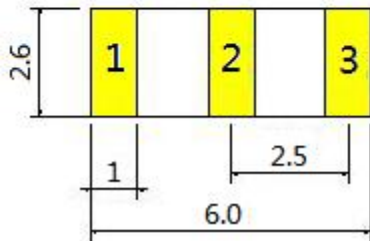
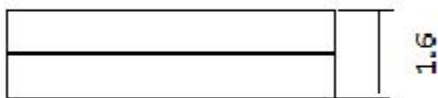

R	SAW Resonator
433T	Part number

Pin Configuration

1	Input/Output
3	Output/Input
2	Case Ground

Test Circuit

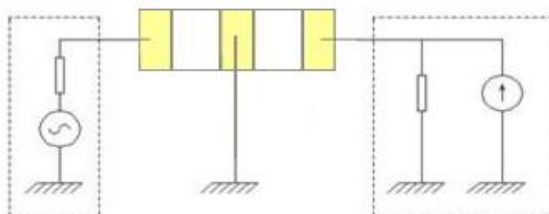

Equivalent LC Model

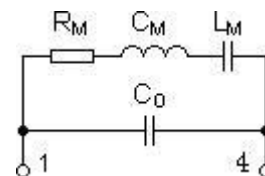

2.Application

Typical Low-Power Transmitter Application

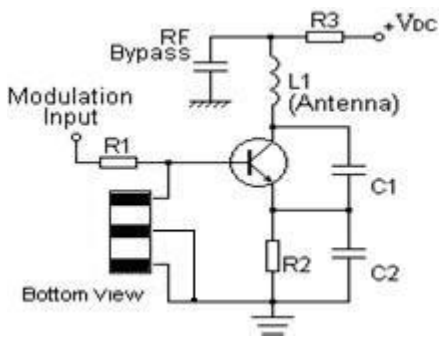

Typical Local Oscillator Application

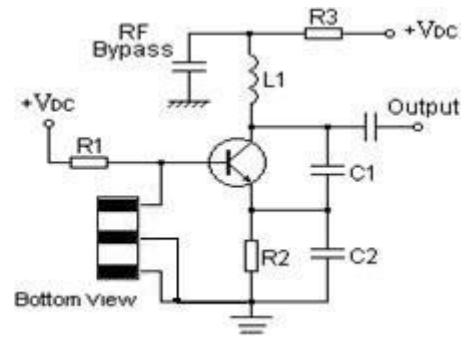

3.Performance

Maximum Rating

Item		Value	Unit
DC Voltage	VDC	±30	V
Operation Temperature	T	-40 ~ +85	°C
Storage Temperature	Tstg	-40 ~ +85	°C
RF Power Dissipation	P	25	dBm

Frequency Response

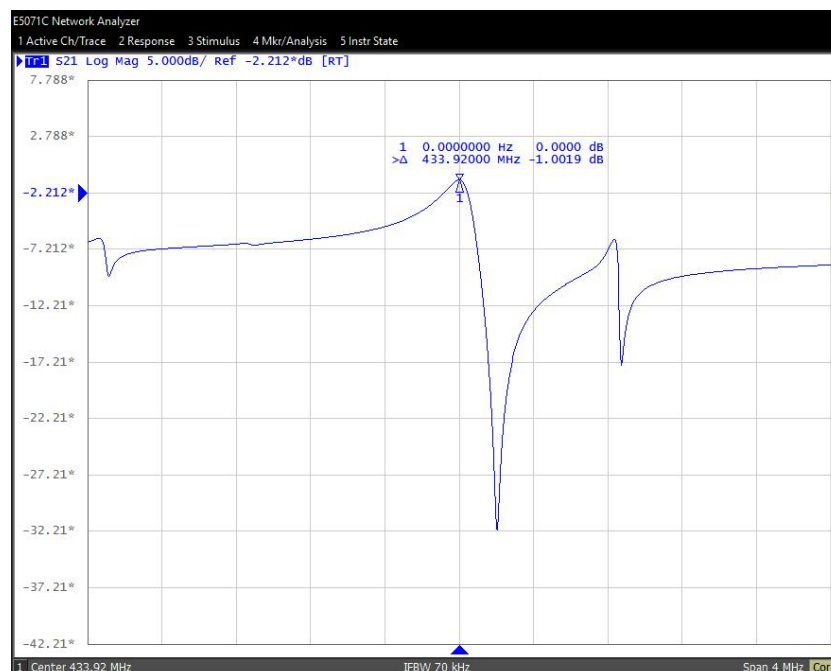

Electronic Characteristics

Test Temperature: 25°C±2°C

Terminating source impedance: 50Ω

Terminating load impedance: 50Ω

Item			Minimum	Typical	Maximum	Unit
Center Frequency	Absolute Frequency	f_c	433.845	433.920	433.995	MHz
	Tolerance from 433.92MHz	Δf_c		±75		KHz
Insertion Loss(min)		IL		1.0	2.0	dB
Quality Factor	Unloaded Q	Q_U		16120		
	50Ω Loaded Q	Q_L		1911		
Frequency Aging	Absolute Value during the First Year	$ f_A $		≤10		ppm/yr
DC Insulation Resistance between Any Two Pins			1.0			MΩ
RF Equivalent RLC Model	Motional Resistance	R_M		12.8	20.0	Ω
	Motional Inductance	L_M		75.3		μH
	Motional Capacitance	C_M		1.76		fF
	Static Capacitance	C_0		2.8		pF

4. Reliability

(The SAW components shall remain electrical performance after tests)

No.	Test item	Test condition
1	Temperature Storage	Temperature: 85°C±2°C , Duration: 250h , Recovery time: 2h±0.5h Temperature: -40°C±3°C , Duration: 250h , Recovery time: 2h±0.5h
2	Humidity Test	Conditions: 60°C±2°C , 90~95% RH Duration: 250h
3	Thermal Shock	Heat cycle conditions: TA=-40°C±3°C, TB=85°C±2°C, t1=t2=30min, Switch time: ≤3min , Cycle time: 100 times , Recovery time : 2h±0.5h.
4	Vibration Fatigue	Frequency of vibration: 10~55Hz Amplitude:1.5mm Directions: X,Y and Z Duration: 2h
5	Drop Test	Cycle time: 10 times Height: 1.0m
6	Solder Ability Test	Temperature: 245°C±5°C Duration: 3.0s--5.0s Depth: DIP--2/3 , SMD--1/5
7	Resistance to Soldering Heat	(1)Thickness of PCB:1mm , Solder condition: 260 °C ± 5 °C , Duration: 10 ± 1s (2)Temperature of Soldering Iron: 350°C±10°C , Duration: 3~4s , Recovery time : 2 ± 0.5h

Notes

1. As a result of the particularity of inner structure of SAW products, it is easy to be broken down by electrostatic, so we should pay attention to **ESD protect** in the test.
2. **Static voltage** between signal load and ground may cause deterioration and destruction of the component. Please avoid static voltage.
3. **Ultrasonic cleaning** may cause deterioration and destruction of the component. Please avoid ultrasonic cleaning.
4. Only leads of component may **be soldered**. Please avoid soldering another part of component.
5. There is a close relationship between the device's performance and **matching network**.
The specifications of this device are based on the test circuit shown above. L and C values may change depending on board layout. Values shown are intended as a guide only.

单击下面可查看定价，库存，交付和生命周期等信息

[>>Kaituo Crystal\(开拓晶体\)](#)