

#### THREE TERMINAL NEGATIVE VOLTAGE REGULATORS -5V, -6V, -7V, -8V, -12V, -15V, -18V, -20V, -24V.

#### FEATURES

- Suitable for C-MOS, TTL, and the other digital IC power supply.
- Internal thermal overload protecting.
- Output Current up to 1.5A.
- Internal short circuit current limiting.
- Package is TO-220AB

#### LINE-UP

ITEM	OUTPUT VOLTAGE (Typ.)	UNIT
KIA7905P	-5	V
KIA7906P	-6	
KIA7907P	-7	
KIA7908P	-8	
KIA7909P	-9	
KIA7910P	-10	
KIA7912P	-12	
KIA7915P	-15	
KIA7918P	-18	
KIA7920P	-20	
KIA7924P	-24	

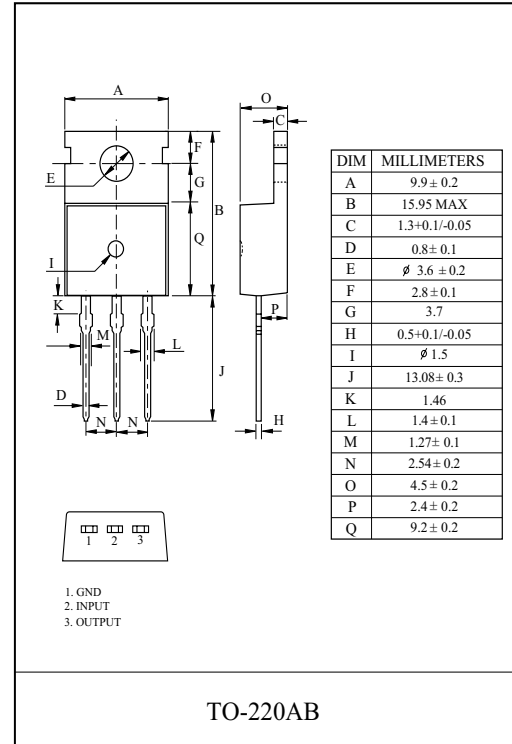

#### MAXIMUM RATINGS (Ta=25°C)

CHARACTERISTIC		SYMBOL	RATING	UNIT
Input Voltage	KIA7905P ~ KIA7915P	V <sub>IN</sub>	-35	V
	KIA7918P ~ KIA7924P		-40	
Power Dissipation-1 (No Heatsink)		P <sub>D1</sub>	1.9	W
Power Dissipation-2 (Infinite Heatsink)		P <sub>D2</sub>	30	W
Operating Junction Temperature		T <sub>j</sub>	-40 ~ 150	°C
Storage Temperature		T <sub>stg</sub>	-55 ~ 150	°C
Maximum Junction Temperature		T <sub>j(max)</sub>	150	°C

# KIA7905P~KIA7924P

## EQUIVALENT CIRCUIT

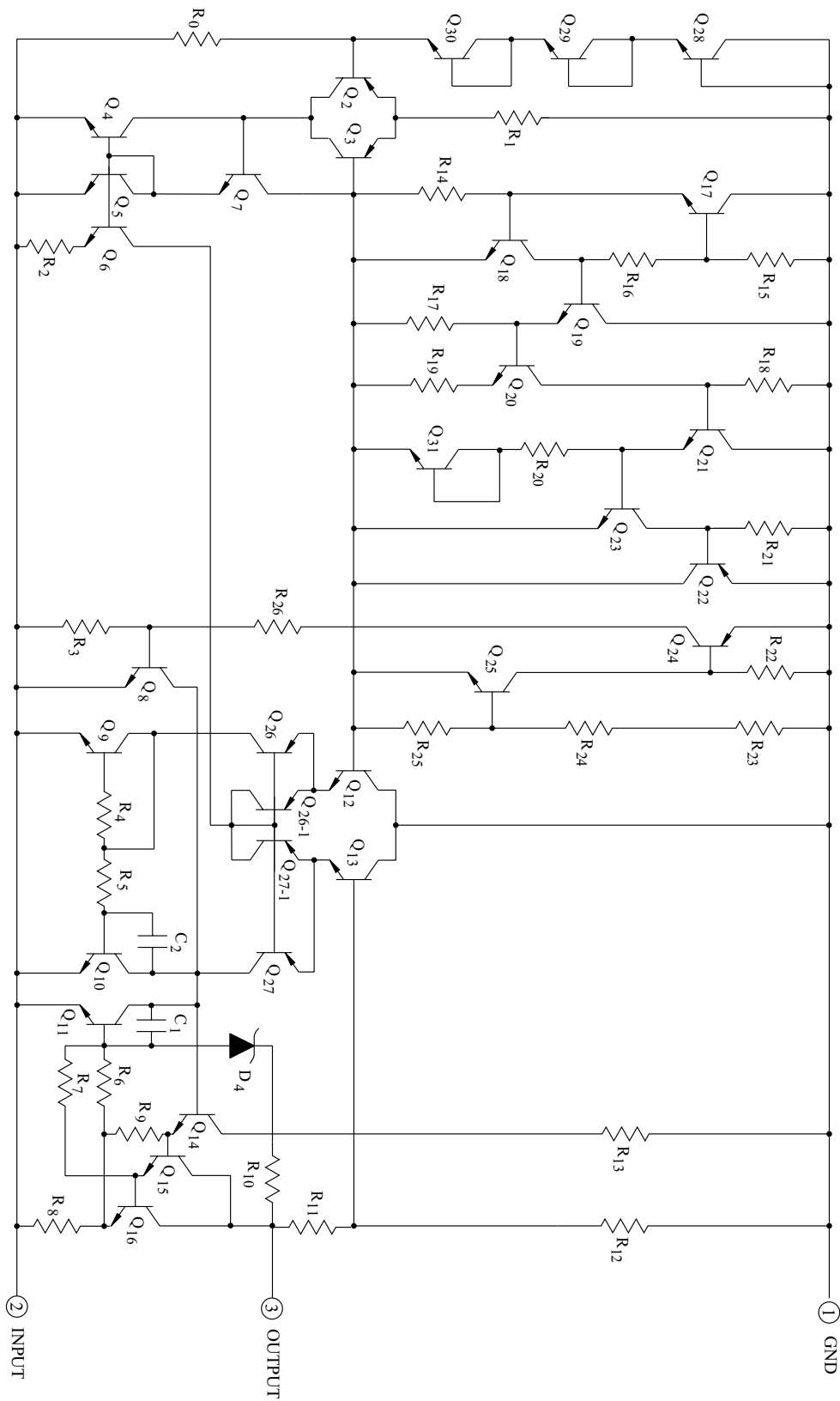

# KIA7905P~KIA7924P

## ELECTRICAL CHARACTERISTICS

### KIA7905P

(Unless otherwise specified,  $V_{IN}=-10V$ ,  $I_{OUT}=500mA$ ,  $0\text{ }^{\circ}C \leq T_j \leq 125\text{ }^{\circ}C$ ,  $C_{IN}=2.2\mu F$ ,  $C_{OUT}=1\mu F$ )

CHARACTERISTIC	SYMBOL	TEST CIRCUIT	TEST CONDITION	MIN.	TYP.	MAX.	UNIT	
Output Voltage	$V_{OUT}$	Fig.1	$T_j=25\text{ }^{\circ}C$	-5.2	-5.0	-4.8	V	
Input Regulation	Reg line	Fig.1	$T_j=25\text{ }^{\circ}C$	$-12V \leq V_{IN} \leq -8V$	-	5	50	mV
				$-25V \leq V_{IN} \leq -7V$	-	10	100	
Load Regulation	Reg load	Fig.1	$T_j=25\text{ }^{\circ}C$	$5mA \leq I_{OUT} \leq 1.5A$	-	10	100	mV
				$250mA \leq I_{OUT} \leq 750mA$	-	3	50	
Output Voltage	$V_{OUT}$	Fig.1	$-20V \leq V_{IN} \leq -7V$ $5mA \leq I_{OUT} \leq 1.0A$	-5.25	-5.0	-4.75	V	
Quiescent Current	$I_B$	Fig.1	$T_j=25\text{ }^{\circ}C$	-	3	6	mA	
Quiescent Current Change	$\Delta I_{BI}$	Fig.1	$-25V \leq V_{IN} \leq -8V$ $5mA \leq I_{OUT} \leq 1.0A$	-	0.1	1.3	mA	
	$\Delta I_{BO}$			-	0.05	0.5		
Output Noise Voltage	$V_{NO}$	Fig.2	$T_a=25\text{ }^{\circ}C$ , $10Hz \leq f \leq 100kHz$	-	100	-	$\mu V_{rms}$	
Ripple Rejection Ratio	RR	Fig.3	$f=120Hz$ , $I_{OUT}=20mA$ ,	54	60	-	dB	
Short Circuit Current Limit	$I_{SC}$	Fig.1	$T_j=25\text{ }^{\circ}C$	-	1.9	-	A	
Average Temperature Coefficient of Output Voltage	$T_{CVO}$	Fig.1	$I_{OUT}=5.0mA$	-	-0.4	-	mV/ $^{\circ}C$	
Dropout Voltage	$V_D$	Fig.1	$T_j=25\text{ }^{\circ}C$ , $I_{OUT}=1A$	-	2.0	-	V	

# KIA7905P~KIA7924P

## ELECTRICAL CHARACTERISTICS

### KIA7906P

(Unless otherwise specified,  $V_{IN}=-11V$ ,  $I_{OUT}=500mA$ ,  $0^{\circ}C \leq T_j \leq 125^{\circ}C$ ,  $C_{IN}=2.2\mu F$ ,  $C_{OUT}=1\mu F$ )

CHARACTERISTIC		SYMBOL	TEST CIRCUIT	TEST CONDITION	MIN.	TYP.	MAX.	UNIT	
Output Voltage		$V_{OUT}$	Fig.1	$T_j=25^{\circ}C$	-6.25	-6.0	-5.75	V	
Input Regulation		Reg line	Fig.1	$T_j=25^{\circ}C$	$-13V \leq V_{IN} \leq -9V$	-	5	60	mV
					$-25V \leq V_{IN} \leq -8V$	-	10	120	
Load Regulation		Reg load	Fig.1	$T_j=25^{\circ}C$	$5mA \leq I_{OUT} \leq 1.5A$	-	10	120	mV
					$250mA \leq I_{OUT} \leq 750mA$	-	3	60	
Output Voltage		$V_{OUT}$	Fig.1	$-21V \leq V_{IN} \leq -9V$ $5mA \leq I_{OUT} \leq 1.0A$	-6.3	-6.0	-5.7	V	
Quiescent Current		$I_B$	Fig.1	$T_j=25^{\circ}C$	-	3	6	mA	
Quiescent Current Change		Line	Fig.1	$-25V \leq V_{IN} \leq -9V$ $5mA \leq I_{OUT} \leq 1.0A$	-	-	1.3	mA	
		Load					0.5		
Output Noise Voltage		$V_{NO}$	Fig.2	$T_a=25^{\circ}C$ , $10Hz \leq f \leq 100kHz$	-	130	-	$\mu V_{rms}$	
Ripple Rejection Ratio		RR	Fig.3	$f=120Hz$ , $I_{OUT}=20mA$ ,	54	60	-	dB	
Short Circuit Current Limit		$I_{SC}$	Fig.1	$T_j=25^{\circ}C$	-	1.9	-	A	
Average Temperature Coefficient of Output Voltage		$T_{CVO}$	Fig.1	$I_{OUT}=5mA$	-	-0.5	-	mV/ $^{\circ}C$	
Dropout Voltage		$V_D$	Fig.1	$T_j=25^{\circ}C$ , $I_{OUT}=1A$	-	2.0	-	V	

# KIA7905P~KIA7924P

## ELECTRICAL CHARACTERISTICS

### KIA7907P

(Unless otherwise specified,  $V_{IN}=-12V$ ,  $I_{OUT}=500mA$ ,  $0\text{ }^{\circ}C \leq T_j \leq 125\text{ }^{\circ}C$ ,  $C_{IN}=2.2\mu F$ ,  $C_{OUT}=1\mu F$ )

CHARACTERISTIC		SYMBOL	TEST CIRCUIT	TEST CONDITION	MIN.	TYP.	MAX.	UNIT	
Output Voltage		$V_{OUT}$	Fig.1	$T_j=25\text{ }^{\circ}C$	-7.28	-7.0	-6.72	V	
Input Regulation		Reg line	Fig.1	$T_j=25\text{ }^{\circ}C$	$-15V \leq V_{IN} \leq -10V$	-	10	70	mV
					$-25V \leq V_{IN} \leq -9V$	-	45	140	
Load Regulation		Reg load	Fig.1	$T_j=25\text{ }^{\circ}C$	$5mA \leq I_{OUT} \leq 1.5A$	-	20	140	mV
					$250mA \leq I_{OUT} \leq 750mA$	-	7	70	
Output Voltage		$V_{OUT}$	Fig.1	$-22V \leq V_{IN} \leq -9V$ $5mA \leq I_{OUT} \leq 1.0A$	-7.35	-	-6.65	V	
Quiescent Current		$I_B$	Fig.1	$T_j=25\text{ }^{\circ}C$	-	4.3	8.0	mA	
Quiescent Current Change		Line	Fig.1	$-25V \leq V_{IN} \leq -9V$	-	-	1.0	mA	
		Load							$5mA \leq I_{OUT} \leq 1.0A$
Output Noise Voltage		$V_{NO}$	Fig.2	$T_a=25\text{ }^{\circ}C$ , $10Hz \leq f \leq 100kHz$	-	49	-	$\mu V_{rms}$	
Ripple Rejection Ratio		RR	Fig.3	$f=120Hz$ , $I_{OUT}=20mA$ ,	60	67	-	dB	
Short Circuit Current Limit		$I_{SC}$	Fig.1	$T_j=25\text{ }^{\circ}C$	-	1.9	-	A	
Average Temperature Coefficient of Output Voltage		$T_{CVO}$	Fig.1	$I_{OUT}=5mA$	-	0.9	-	mV/ $^{\circ}C$	
Dropout Voltage		$V_D$	Fig.1	$T_j=25\text{ }^{\circ}C$ , $I_{OUT}=1A$	-	2.0	-	V	

# KIA7905P~KIA7924P

## ELECTRICAL CHARACTERISTICS

### KIA7908P

(Unless otherwise specified,  $V_{IN}=-14V$ ,  $I_{OUT}=500mA$ ,  $0^{\circ}C \leq T_j \leq 125^{\circ}C$ ,  $C_{IN}=2.2\mu F$ ,  $C_{OUT}=1\mu F$ )

CHARACTERISTIC		SYMBOL	TEST CIRCUIT	TEST CONDITION	MIN.	TYP.	MAX.	UNIT	
Output Voltage		$V_{OUT}$	Fig.1	$T_j=25^{\circ}C$	-8.3	-8.0	-7.7	V	
Input Regulation		Reg line	Fig.1	$T_j=25^{\circ}C$	$-17V \leq V_{IN} \leq -11V$	-	5	80	mV
					$-25V \leq V_{IN} \leq -10.5V$	-	10	100	
Load Regulation		Reg load	Fig.1	$T_j=25^{\circ}C$	$5mA \leq I_{OUT} \leq 1.5A$	-	12	160	mV
					$250mA \leq I_{OUT} \leq 750mA$	-	4	80	
Output Voltage		$V_{OUT}$	Fig.1	$-23V \leq V_{IN} \leq -11.5V$ $5mA \leq I_{OUT} \leq 1.0A$	-8.4	-8.0	-7.6	V	
Quiescent Current		$I_B$	Fig.1	$T_j=25^{\circ}C$	-	3	6	mA	
Quiescent Current Change		Line	Fig.1	$-25V \leq V_{IN} \leq -11.5V$ $5mA \leq I_{OUT} \leq 1.0A$	-	0.1	1.0	mA	
		Load			$\Delta I_{BO}$	-	0.05		0.5
Output Noise Voltage		$V_{NO}$	Fig.2	$T_a=25^{\circ}C$ , $10Hz \leq f \leq 100kHz$	-	175	-	$\mu V_{rms}$	
Ripple Rejection Ratio		RR	Fig.3	$f=120Hz$ , $I_{OUT}=20mA$ ,	54	60	-	dB	
Short Circuit Current Limit		$I_{SC}$	Fig.1	$T_j=25^{\circ}C$	-	1.9	-	A	
Average Temperature Coefficient of Output Voltage		$T_{CVO}$	Fig.1	$I_{OUT}=5mA$	-	-0.6	-	mV/ $^{\circ}C$	
Dropout Voltage		$V_D$	Fig.1	$T_j=25^{\circ}C$ , $I_{OUT}=1A$	-	2.0	-	V	

# KIA7905P~KIA7924P

## ELECTRICAL CHARACTERISTICS

### KIA7909P

(Unless otherwise specified,  $V_{IN}=-15V$ ,  $I_{OUT}=500mA$ ,  $0\text{ }^{\circ}C \leq T_j \leq 125\text{ }^{\circ}C$ ,  $C_{IN}=2.2\mu F$ ,  $C_{OUT}=1\mu F$ )

CHARACTERISTIC		SYMBOL	TEST CIRCUIT	TEST CONDITION	MIN.	TYP.	MAX.	UNIT	
Output Voltage		$V_{OUT}$	Fig.1	$T_j=25\text{ }^{\circ}C$	-9.3	-9.0	-8.7	V	
Input Regulation		Reg line	Fig.1	$T_j=25\text{ }^{\circ}C$	$-19V \leq V_{IN} \leq -13V$	-	5	90	mV
					$-26V \leq V_{IN} \leq -11.5V$	-	10	100	
Load Regulation		Reg load	Fig.1	$T_j=25\text{ }^{\circ}C$	$5mA \leq I_{OUT} \leq 1.5A$	-	10	150	mV
					$250mA \leq I_{OUT} \leq 750mA$	-	5	120	
Output Voltage		$V_{OUT}$	Fig.1	$-24V \leq V_{IN} \leq -11.5V$ $5mA \leq I_{OUT} \leq 1.0A$	-9.4	-9.0	-8.6	V	
Quiescent Current		$I_B$	Fig.1	$T_j=25\text{ }^{\circ}C$	-	3	6	mA	
Quiescent Current Change		Line	Fig.1	$-26.5V \leq V_{IN} \leq -13V$	-	0.1	1.0	mA	
		Load							$5mA \leq I_{OUT} \leq 1.0A$
Output Noise Voltage		$V_{NO}$	Fig.2	$T_a=25\text{ }^{\circ}C$ , $10Hz \leq f \leq 100kHz$	-	180	-	$\mu V_{rms}$	
Ripple Rejection Ratio		RR	Fig.3	$f=120Hz$ , $I_{OUT}=20mA$ ,	54	60	-	dB	
Short Circuit Current Limit		$I_{SC}$	Fig.1	$T_j=25\text{ }^{\circ}C$	-	1.9	-	A	
Average Temperature Coefficient of Output Voltage		$T_{CVO}$	Fig.1	$I_{OUT}=5mA$	-	-0.7	-	mV/ $^{\circ}C$	
Dropout Voltage		$V_D$	Fig.1	$T_j=25\text{ }^{\circ}C$ , $I_{OUT}=1A$	-	2.0	-	V	

# KIA7905P~KIA7924P

## ELECTRICAL CHARACTERISTICS

### KIA7910P

(Unless otherwise specified,  $V_{IN}=-16V$ ,  $I_{OUT}=500mA$ ,  $0^{\circ}C \leq T_j \leq 125^{\circ}C$ ,  $C_{IN}=2.2\mu F$ ,  $C_{OUT}=1\mu F$ )

CHARACTERISTIC		SYMBOL	TEST CIRCUIT	TEST CONDITION	MIN.	TYP.	MAX.	UNIT	
Output Voltage		$V_{OUT}$	Fig.1	$T_j=25^{\circ}C$	-10.4	-10	-9.6	V	
Input Regulation		Reg line	Fig.1	$T_j=25^{\circ}C$	$-20V \leq V_{IN} \leq -14V$	-	5	100	mV
					$-27V \leq V_{IN} \leq -12.5V$	-	10	110	
Load Regulation		Reg load	Fig.1	$T_j=25^{\circ}C$	$5mA \leq I_{OUT} \leq 1.5A$	-	10	180	mV
					$250mA \leq I_{OUT} \leq 750mA$	-	6	120	
Output Voltage		$V_{OUT}$	Fig.1	$-25V \leq V_{IN} \leq -12.5V$ $5mA \leq I_{OUT} \leq 1.0A$	-10.5	-10	-9.5	V	
Quiescent Current		$I_B$	Fig.1	$T_j=25^{\circ}C$	-	3	6	mA	
Quiescent Current Change		Line	Fig.1	$-27.5V \leq V_{IN} \leq -14V$	-	0.1	1.0	mA	
		Load							$5mA \leq I_{OUT} \leq 1.0A$
Output Noise Voltage		$V_{NO}$	Fig.2	$T_a=25^{\circ}C$ , $10Hz \leq f \leq 100kHz$	-	190	-	$\mu V_{rms}$	
Ripple Rejection Ratio		RR	Fig.3	$f=120Hz$ , $I_{OUT}=20mA$	54	60	-	dB	
Short Circuit Current Limit		$I_{SC}$	Fig.1	$T_j=25^{\circ}C$	-	1.9	-	A	
Average Temperature Coefficient of Output Voltage		$T_{CVO}$	Fig.1	$I_{OUT}=5mA$	-	-0.7	-	mV/ $^{\circ}C$	
Dropout Voltage		$V_D$	Fig.1	$T_j=25^{\circ}C$ , $I_{OUT}=1A$	-	2.0	-	V	



# KIA7905P~KIA7924P

## ELECTRICAL CHARACTERISTICS

### KIA7912P

(Unless otherwise specified,  $V_{IN}=-18V$ ,  $I_{OUT}=500mA$ ,  $0^{\circ}C \leq T_j \leq 125^{\circ}C$ ,  $C_{IN}=2.2\mu F$ ,  $C_{OUT}=1\mu F$ )

CHARACTERISTIC		SYMBOL	TEST CIRCUIT	TEST CONDITION	MIN.	TYP.	MAX.	UNIT	
Output Voltage		$V_{OUT}$	Fig.1	$T_j=25^{\circ}C$	-12.5	-12	-11.5	V	
Input Regulation		Reg line	Fig.1	$T_j=25^{\circ}C$	$-22V \leq V_{IN} \leq -16V$	-	6	120	mV
					$-30V \leq V_{IN} \leq -14.5V$	-	12	240	
Load Regulation		Reg load	Fig.1	$T_j=25^{\circ}C$	$5mA \leq I_{OUT} \leq 1.5A$	-	12	240	mV
					$250mA \leq I_{OUT} \leq 750mA$	-	4	120	
Output Voltage		$V_{OUT}$	Fig.1	$-27V \leq V_{IN} \leq -15.5V$ $5mA \leq I_{OUT} \leq 1.0A$	-12.6	-12	-11.4	V	
Quiescent Current		$I_B$	Fig.1	$T_j=25^{\circ}C$	-	3	6	mA	
Quiescent Current Change		Line	Fig.1	$-30V \leq V_{IN} \leq -15V$ $5mA \leq I_{OUT} \leq 1.0A$	-	0.1	1.0	mA	
		Load			$\Delta I_{BO}$	-	0.05		0.5
Output Noise Voltage		$V_{NO}$	Fig.2	$T_a=25^{\circ}C$ , $10Hz \leq f \leq 100kHz$	-	200	-	$\mu V_{rms}$	
Ripple Rejection Ratio		RR	Fig.3	$f=120Hz$ , $I_{OUT}=20mA$ ,	54	60	-	dB	
Short Circuit Current Limit		$I_{SC}$	Fig.1	$T_j=25^{\circ}C$	-	1.9	-	A	
Average Temperature Coefficient of Output Voltage		$T_{CVO}$	Fig.1	$I_{OUT}=5mA$	-	-0.8	-	mV/ $^{\circ}C$	
Dropout Voltage		$V_D$	Fig.1	$T_j=25^{\circ}C$ , $I_{OUT}=1A$	-	2.0	-	V	

# KIA7905P~KIA7924P

## ELECTRICAL CHARACTERISTICS

### KIA7915P

(Unless otherwise specified,  $V_{IN}=-23V$ ,  $I_{OUT}=500mA$ ,  $0^{\circ}C \leq T_j \leq 125^{\circ}C$ ,  $C_{IN}=2.2\mu F$ ,  $C_{OUT}=1\mu F$ )

CHARACTERISTIC		SYMBOL	TEST CIRCUIT	TEST CONDITION	MIN.	TYP.	MAX.	UNIT	
Output Voltage		$V_{OUT}$	Fig.1	$T_j=25^{\circ}C$	-15.6	-15	-14.4	V	
Input Regulation		Reg line	Fig.1	$T_j=25^{\circ}C$	$-26V \leq V_{IN} \leq -20V$	-	6	150	mV
					$-30V \leq V_{IN} \leq -17.5V$	-	12	300	
Load Regulation		Reg load	Fig.1	$T_j=25^{\circ}C$	$5mA \leq I_{OUT} \leq 1.5A$	-	12	300	mV
					$250mA \leq I_{OUT} \leq 750mA$	-	4	150	
Output Voltage		$V_{OUT}$	Fig.1	$-30V \leq V_{IN} \leq -18V$ $5mA \leq I_{OUT} \leq 1.0A$	-15.75	-15	-14.25	V	
Quiescent Current		$I_B$	Fig.1	$T_j=25^{\circ}C$	-	3	6	mA	
Quiescent Current Change		Line	Fig.1	$-30V \leq V_{IN} \leq -17.5V$ $5mA \leq I_{OUT} \leq 1.0A$	-	0.1	1.0	mA	
		Load			-	0.05	0.5		
Output Noise Voltage		$V_{NO}$	Fig.2	$T_a=25^{\circ}C$ , $10Hz \leq f \leq 100kHz$	-	250	-	$\mu V_{rms}$	
Ripple Rejection Ratio		RR	Fig.3	$f=120Hz$ , $I_{OUT}=20mA$ ,	54	60	-	dB	
Short Circuit Current Limit		$I_{SC}$	Fig.1	$T_j=25^{\circ}C$	-	1.9	-	A	
Average Temperature Coefficient of Output Voltage		$T_{CVO}$	Fig.1	$I_{OUT}=5mA$	-	-0.9	-	mV/ $^{\circ}C$	
Dropout Voltage		$V_D$	Fig.1	$T_j=25^{\circ}C$ , $I_{OUT}=1A$	-	2.0	-	V	

# KIA7905P~KIA7924P

## ELECTRICAL CHARACTERISTICS

### KIA7918P

(Unless otherwise specified,  $V_{IN}=-27V$ ,  $I_{OUT}=500mA$ ,  $0^{\circ}C \leq T_j \leq 125^{\circ}C$ ,  $C_{IN}=2.2\mu F$ ,  $C_{OUT}=1\mu F$ )

CHARACTERISTIC		SYMBOL	TEST CIRCUIT	TEST CONDITION	MIN.	TYP.	MAX.	UNIT
Output Voltage		$V_{OUT}$	Fig.1	$T_j=25^{\circ}C$	-18.7	-18	-17.3	V
Input Regulation	Reg line	Fig.1	$T_j=25^{\circ}C$	$-30V \leq V_{IN} \leq -24V$	-	8	180	mV
				$-33V \leq V_{IN} \leq -21V$	-	15	360	
Load Regulation	Reg load	Fig.1	$T_j=25^{\circ}C$	$5mA \leq I_{OUT} \leq 1.5A$	-	15	360	mV
				$250mA \leq I_{OUT} \leq 750mA$	-	5	180	
Output Voltage		$V_{OUT}$	Fig.1	$-33V \leq V_{IN} \leq -22.5V$ $5mA \leq I_{OUT} \leq 1.0A$	-18.85	-18	-17.15	V
Quiescent Current		$I_B$	Fig.1	$T_j=25^{\circ}C$	-	3	6	mA
Quiescent Current Change	Line	$\Delta I_{BI}$	Fig.1	$-33V \leq V_{IN} \leq -22V$	-	-	1.0	mA
	Load	$\Delta I_{BO}$		$5mA \leq I_{OUT} \leq 1.0A$	-	-	0.5	
Output Noise Voltage		$V_{NO}$	Fig.2	$T_a=25^{\circ}C$ , $10Hz \leq f \leq 100kHz$	-	300	-	$\mu V_{rms}$
Ripple Rejection Ratio		RR	Fig.3	$f=120Hz$ , $I_{OUT}=20mA$ ,	54	60	-	dB
Short Circuit Current Limit		$I_{SC}$	Fig.1	$T_j=25^{\circ}C$	-	1.9	-	A
Average Temperature Coefficient of Output Voltage		$T_{CVO}$	Fig.1	$I_{OUT}=5mA$	-	-1.0	-	mV/ $^{\circ}C$
Dropout Voltage		$V_D$	Fig.1	$T_j=25^{\circ}C$ , $I_{OUT}=1A$	-	2.0	-	V

# KIA7905P~KIA7924P

## ELECTRICAL CHARACTERISTICS

### KIA7920P

(Unless otherwise specified,  $V_{IN}=-30V$ ,  $I_{OUT}=500mA$ ,  $0^{\circ}C \leq T_j \leq 125^{\circ}C$ ,  $C_{IN}=2.2\mu F$ ,  $C_{OUT}=1\mu F$ )

CHARACTERISTIC		SYMBOL	TEST CIRCUIT	TEST CONDITION	MIN.	TYP.	MAX.	UNIT	
Output Voltage		$V_{OUT}$	Fig.1	$T_j=25^{\circ}C$	-20.8	-20	-19.2	V	
Input Regulation		Reg line	Fig.1	$T_j=25^{\circ}C$	$-32V \leq V_{IN} \leq -26V$	-	10	180	mV
					$-35V \leq V_{IN} \leq -24V$	-	18	360	
Load Regulation		Reg load	Fig.1	$T_j=25^{\circ}C$	$5mA \leq I_{OUT} \leq 1.5A$	-	18	360	mV
					$250mA \leq I_{OUT} \leq 750mA$	-	10	180	
Output Voltage		$V_{OUT}$	Fig.1	$-35V \leq V_{IN} \leq -24$ $5mA \leq I_{OUT} \leq 1.0A$	-21.0	-20	-19.0	V	
Quiescent Current		$I_B$	Fig.1	$T_j=25^{\circ}C$	-	3	6	mA	
Quiescent Current Change		Line	Fig.1	$-36.5V \leq V_{IN} \leq -25V$	-	-	1.0	mA	
		Load							$5mA \leq I_{OUT} \leq 1.0A$
Output Noise Voltage		$V_{NO}$	Fig.2	$T_a=25^{\circ}C$ , $10Hz \leq f \leq 100kHz$	-	350	-	$\mu V_{rms}$	
Ripple Rejection Ratio		RR	Fig.3	$f=120Hz$ , $I_{OUT}=20mA$	54	60	-	dB	
Short Circuit Current Limit		$I_{SC}$	Fig.1	$T_j=25^{\circ}C$	-	1.9	-	A	
Average Temperature Coefficient of Output Voltage		$T_{CVO}$	Fig.1	$I_{OUT}=5mA$	-	-1.0	-	mV/ $^{\circ}C$	
Dropout Voltage		$V_D$	Fig.1	$T_j=25^{\circ}C$ , $I_{OUT}=1A$	-	2.0	-	V	

# KIA7905P~KIA7924P

## ELECTRICAL CHARACTERISTICS

### KIA7924P

(Unless otherwise specified,  $V_{IN}=-33V$ ,  $I_{OUT}=500mA$ ,  $0\text{ }^{\circ}C \leq T_j \leq 125\text{ }^{\circ}C$ ,  $C_{IN}=0.33\mu F$ ,  $C_{OUT}=0.1\mu F$ )

CHARACTERISTIC	SYMBOL	TEST CIRCUIT	TEST CONDITION	MIN.	TYP.	MAX.	UNIT	
Output Voltage	$V_{OUT}$	Fig.1	$T_j=25\text{ }^{\circ}C$	-25	-24	-23	V	
Input Regulation	Reg line	Fig.1	$T_j=25\text{ }^{\circ}C$	$-36V \leq V_{IN} \leq -30V$	-	8	240	mV
				$-38V \leq V_{IN} \leq -27V$	-	15	480	
Load Regulation	Reg load	Fig.1	$T_j=25\text{ }^{\circ}C$	$5mA \leq I_{OUT} \leq 1.5A$	-	15	480	mV
				$250mA \leq I_{OUT} \leq 750mA$	-	5	240	
Output Voltage	$V_{OUT}$	Fig.1	$-38V \leq V_{IN} \leq -27V$ $5mA \leq I_{OUT} \leq 1.0A$	-25.2	-24	-22.5	V	
Quiescent Current	$I_B$	Fig.1	$T_j=25\text{ }^{\circ}C$	-	3	6	mA	
Quiescent Current Change	Line	Fig.1	$-38V \leq V_{IN} \leq -27V$ $5mA \leq I_{OUT} \leq 1.0A$	-	-	1.0	mA	
	Load							$\Delta I_{BO}$
Output Noise Voltage	$V_{NO}$	Fig.2	$T_a=25\text{ }^{\circ}C$ , $10Hz \leq f \leq 100kHz$	-	400	-	$\mu V_{rms}$	
Ripple Rejection Ratio	RR	Fig.3	$f=120Hz$ , $I_{OUT}=20mA$ ,	54	60	-	dB	
Short Circuit Current Limit	$I_{SC}$	Fig.1	$T_j=25\text{ }^{\circ}C$	-	1.9	-	A	
Average Temperature Coefficient of Output Voltage	$T_{CVO}$	Fig.1	$I_{OUT}=5mA$	-	-1.0	-	mV/ $^{\circ}C$	
Dropout Voltage	$V_D$	Fig.1	$T_a=25\text{ }^{\circ}C$ , $I_{OUT}=1A$	-	2.0	-	V	

# KIA7905P~KIA7924P

## TEST CIRCUIT

Fig.1 Standard Test Circuit

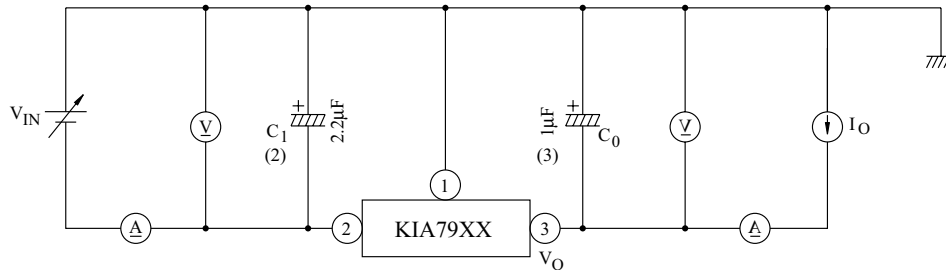

Notes : (1) To specify an output voltage, substitute voltage value for "XX"

(2) Required for stability. For value given, capacitor must be solid tantalum. If aluminium electrolytics are used, at least ten times value shown should be selected.  $C_1$  is required if regulator is located an appreciable distance from power supply filter.

(3) To improve transient response. If large capacitors are used, a high current diode from input to output (1N4001 or similar) should be introduced to protect the device from momentary input short circuit.

Fig.2  $V_{NO}$  Test Circuit

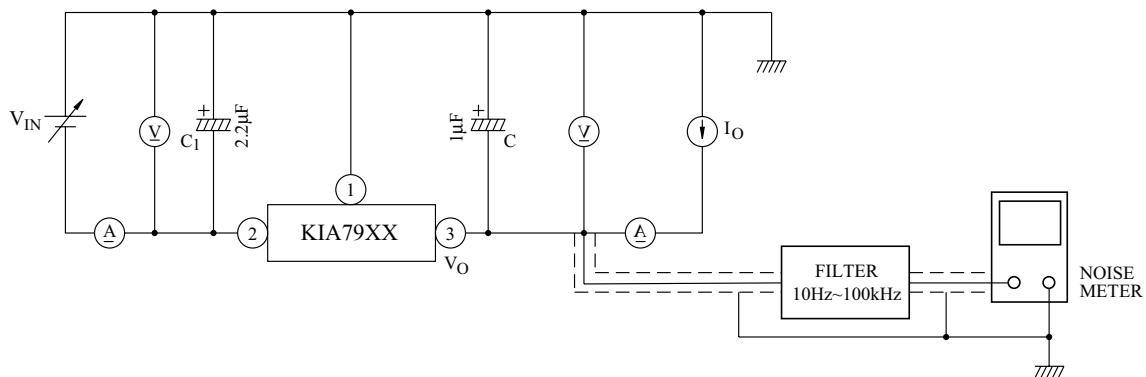
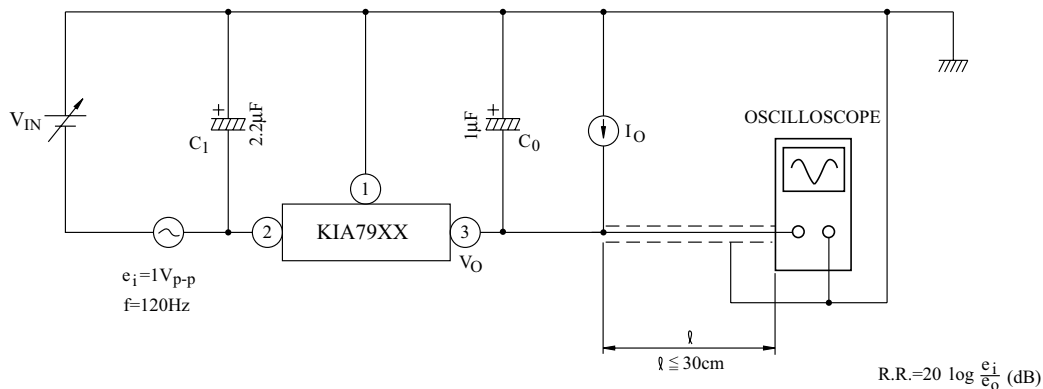

Fig.3 Ripple Rejection Test Circuit



# KIA7905P~KIA7924P

Fig. 4

$I_B - T_j$

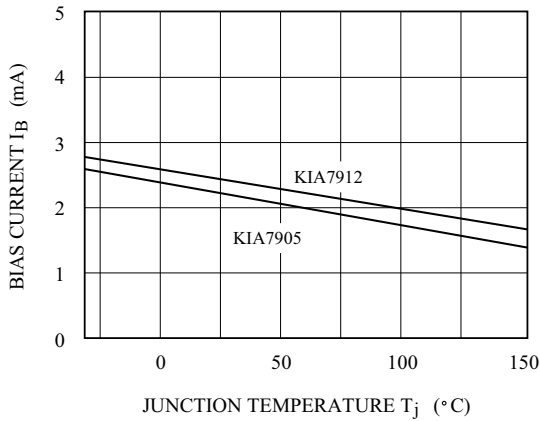

Fig. 5

$V_{OUT} - T_j$

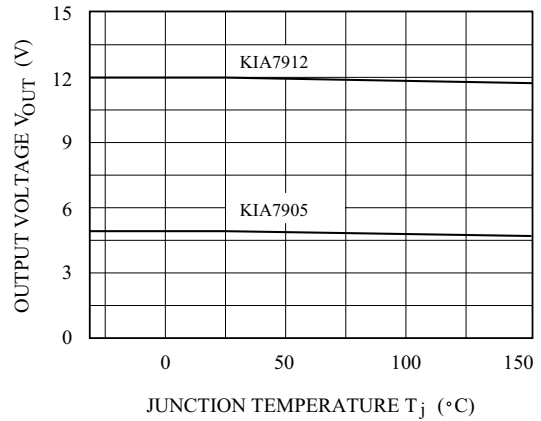

Fig. 6

$RR - I_{OUT}$

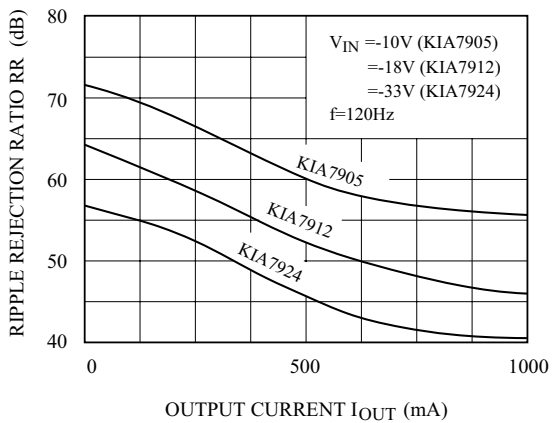

Fig. 7

$I_{SC} - V_{IN}$

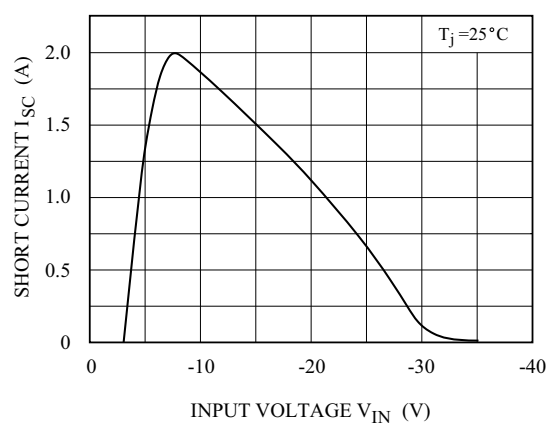

Fig. 8

$V_D - T_j$

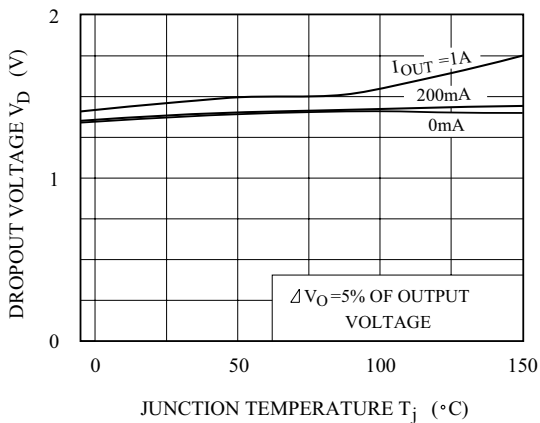
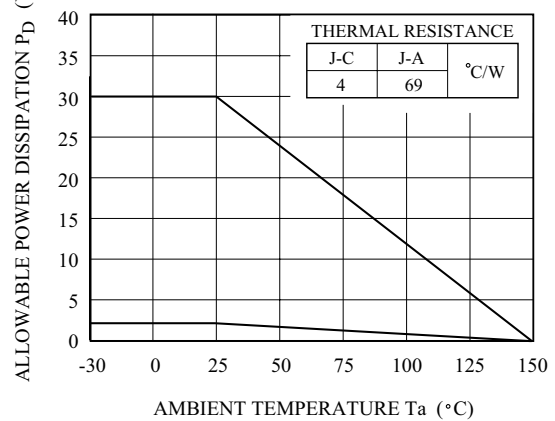

Fig. 9

$P_D - T_a$



单击下面可查看定价，库存，交付和生命周期等信息

[>>KEC\(开益禧\)](#)