

**GENERAL PURPOSE APPLICATION.
DPAK FOR SURFACE MOUNT APPLICATIONS.**

FEATURES

- Low Collector Saturation Voltage
: $V_{CE(sat)} = -1.0V(\text{Max.})$ at $I_C = -2A, I_B = -0.2A$.
- Complementary to KTC2020D.
- Suffix U : Qualified to AEC-Q 101
ex) KTA1040D-Y-RTF/HU

MAXIMUM RATING (Ta=25 °C)

CHARACTERISTIC	SYMBOL	RATING	UNIT
Collector-Base Voltage	V_{CBO}	-60	V
Collector-Emitter Voltage	V_{CEO}	-60	V
Emitter-Base Voltage	V_{EBO}	-7	V
Collector Current	I_C	-3	A
Base Current	I_B	-0.5	A
Collector Power Dissipation	P_C	Ta=25°C	1.0
		Tc=25°C	20
Junction Temperature	T_j	150	°C
Storage Temperature Range	T_{stg}	-55 ~ 150	°C

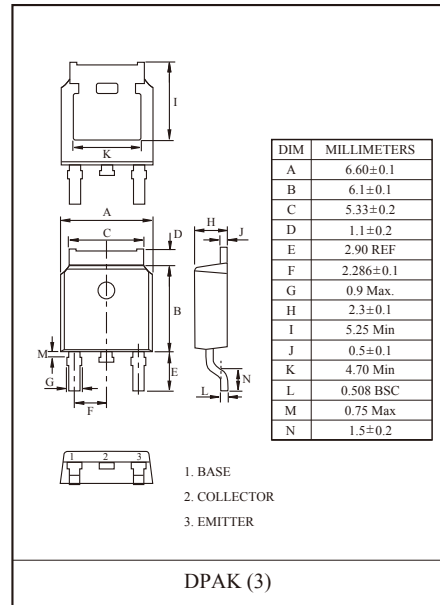
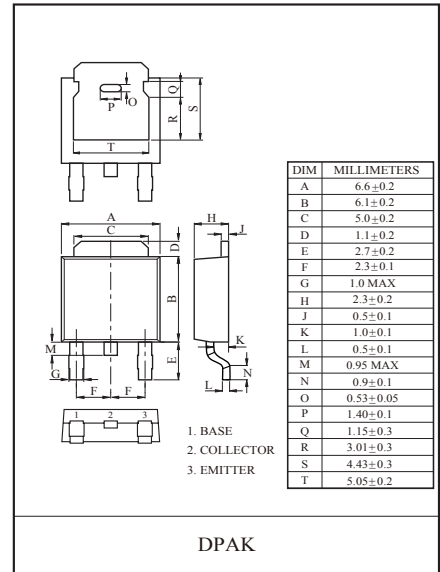

ELECTRICAL CHARACTERISTICS (Ta=25°C)

CHARACTERISTIC	SYMBOL	TEST CONDITION	MIN.	TYP.	MAX.	UNIT
Collector Cut-off Current	I_{CBO}	$V_{CB} = -60V, I_E = 0$	-	-	-1	μA
Emitter Cut-off Current	I_{EBO}	$V_{EB} = -7V, I_C = 0$	-	-	-1	μA
Collector-Emitter Breakdown Voltage	$V_{(BR)CEO}$	$I_C = -50mA, I_B = 0$	-60	-	-	V
DC Current Gain	$h_{FE(1)}$ (Note)	$V_{CE} = -5V, I_C = -0.5A$	100	-	300	
	$h_{FE(2)}$	$V_{CE} = -5V, I_C = -3A$	20	-	-	
Collector Emitter Saturation Voltage	$V_{CE(sat)}$	$I_C = -2A, I_B = -0.2A$	-	-0.25	-1.0	V
Base-Emitter Voltage	V_{BE}	$V_{CE} = -5V, I_C = -0.5A$	-	-0.7	-1.0	V
Transition Frequency	f_T	$V_{CE} = -5V, I_C = -0.5A$	-	30	-	MHz
Collector Output Capacitance	C_{ob}	$V_{CB} = -10V, I_E = 0, f = 1MHz$	-	45	-	pF
Switching Time	Turn-on Time	t_{on}	-	0.4	-	μS
	Storage Time	t_{stg}	-	1.7	-	
	Fall Time	t_f	-	0.5	-	

$-I_{B1} = I_{B2} = 0.2A$
DUTY CYCLE ≤ 1%

Note : $h_{FE(1)}$ Classification Y:100~200, GR:150~300.

KTA1040D

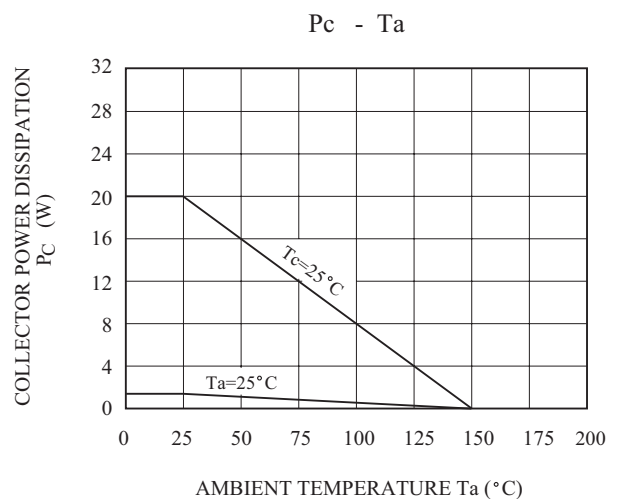
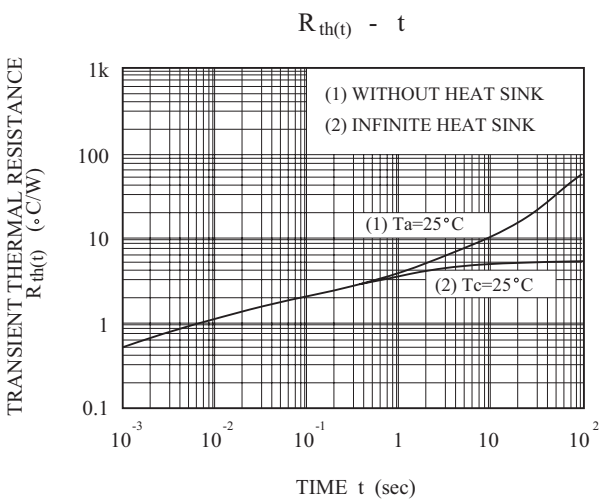
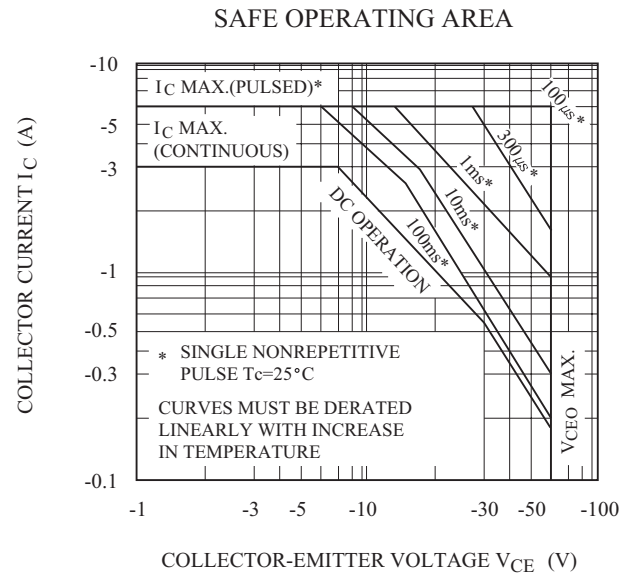
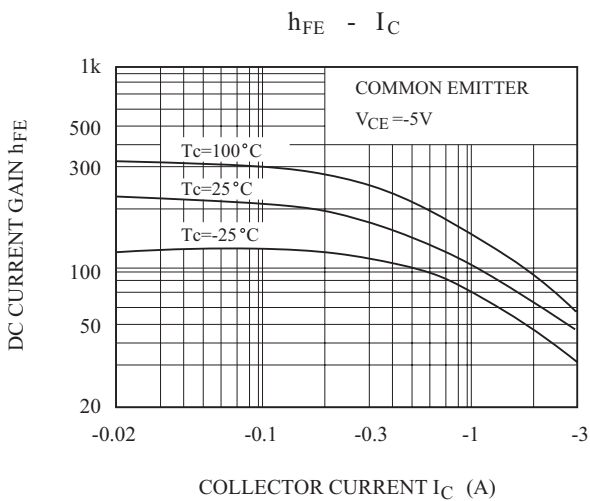
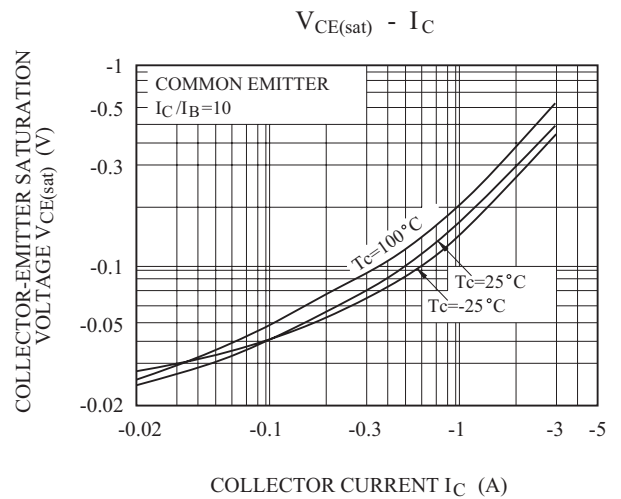
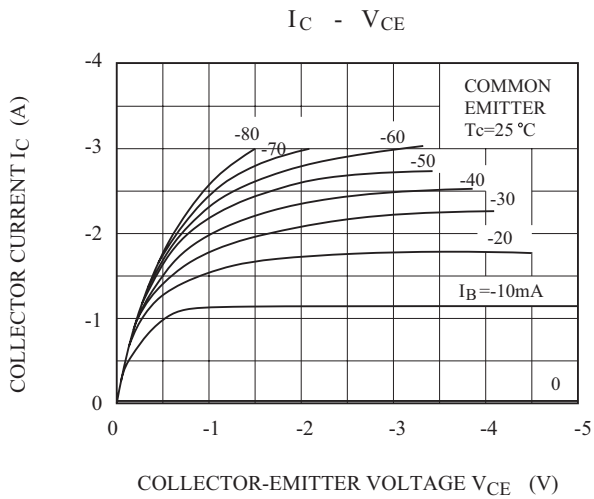

单击下面可查看定价，库存，交付和生命周期等信息

[>>KEC\(开益禧\)](#)