

linear dimension(Tolerances Standard GB/T 14486-2008)								—	\square	\perp
variable range	to	over	over	over	over	over	over	to	over	over
	6	6 to 10	10 to 30	30 to 60	60 to 100	100 to 160	160 to		10 to 100	100 to
tolerance	± 0.20	± 0.30	± 0.50	± 0.70	± 1.00	± 1.30	± 1.60	0.10	0.30	0.60

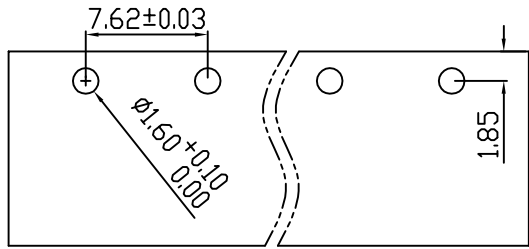

PCB LAYOUT

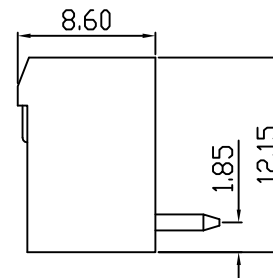
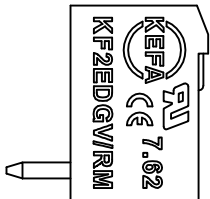
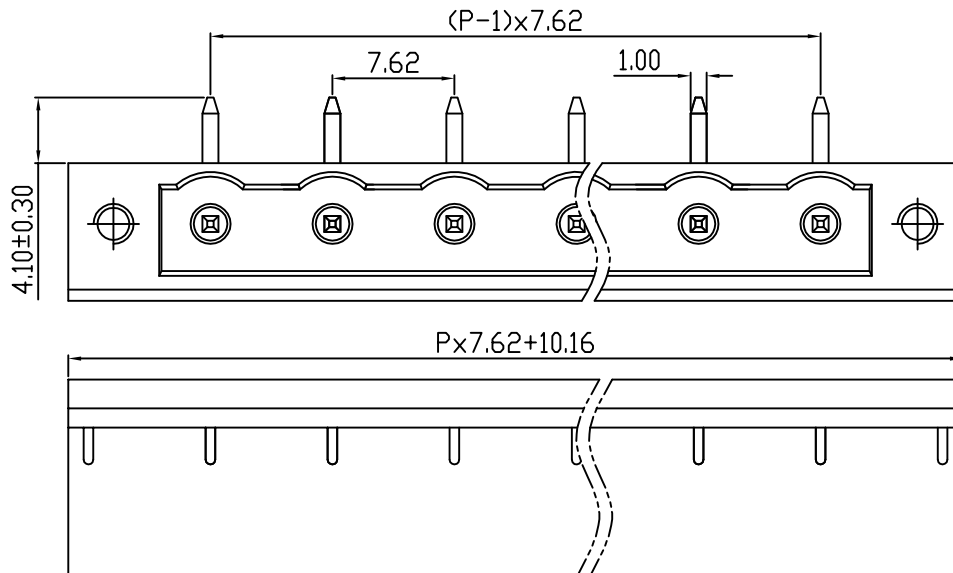

REVISION RECORD				
REV.	DESCRIPTION	ECN No.	APPROVED	DATE
A	新发行		CLF	21.03.15

UL/CUL 技术参数 UL/CUL Technical Data				
等级 Use Group	B	C	D	
额定电压 Rated Voltage [V]	300	-	300	
额定电流 Rated Current [A]	10	-	10	
接线范围 Wire Range	-			
单/多芯线 Solid/Stranded [AWG]	-			
耐电压 Withstanding Voltage	1600V/1Min			
IEC 技术参数 IEC Technical Data				
过电压类别 Overvoltage Category	III	III	II	
污染等级 Contamination Class	3	2	2	
额定电压 Rated Voltage [V]	-	630	1000	
额定电流 Rated Current [A]	-	15	15	
额定冲击电压 Impulse withstand voltage ^a [KV]	-	6.0	6.0	
导线截面积 Conductor cross section	-			
硬质/柔性导线 Solid/flexible [mm ²]	-			
材料 Material				
绝缘材料 Insulation Material	PA66			
阻燃等级 Inflammability	UL94V-0			
导体材料 Contactor Material	铜合金 Copper alloy			
导体表面镀层 Contactive Coating	镀锡 Tin Plated			
一般参数 Other Data				
间距 Pitch [mm]	7.62			
极数 Poles [P]	2-24			
剥线长度 Stripping Length [mm]	-			
螺丝 Screw/扭矩 Torque(Max) [N.m]	-			
工作温度 Operating temperatur [°C]	-40~+105			
引针尺寸 Pin Dimensions [mm]	4.1			
PCB板孔径 PCB Hole Diameter [mm]	1.6			

DES.	FZM	DATE	21.03.15	单位/UNITS	mm	尺寸/SIZE	A4	比例/SCALE	1:1	第三视角/THIRD ANGLE PROJECTION	版本/REV	A
CHK.	SY	DATE	21.03.15	慈溪市科发电子有限公司 CIXI KEFA ELECTRONICS CO., LTD				名称/TITLE	KF2EDGRM-7.62			
APP.	CLF	DATE	21.03.15									

单击下面可查看定价，库存，交付和生命周期等信息

[>>KEFA\(科发\)](#)