

## Overview

Dual in-line (DIL) metallized polyester (PET) film capacitor for surface mounting is encapsulated in a self-extinguishing material, meeting the requirements of UL 94 V-0.

## Applications

Typical applications include high frequency switched-mode power supplies, DC/DC converters and input/output filtering.

## Benefits

- Rated voltage: 50 – 630 VDC
- Rated voltage: 30 – 220 VAC
- Capacitance range: 0.033 – 15  $\mu$ F
- Capacitance tolerance:  $\pm$ 5%,  $\pm$ 10%, other tolerances on request
- Climatic category: 55/125/56
- RoHS compliant and lead-free terminations
- Operating temperature range of  $-55^{\circ}\text{C}$  to  $+125^{\circ}\text{C}$

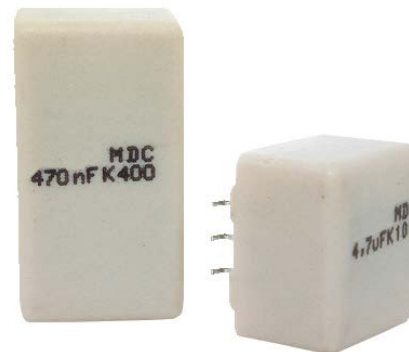

## Legacy Part Number System

MDC	10	333	K	50	A52	P3	TUBE
Series	Lead Spacing (mm)	Capacitance Code (pF)	Capacitance Tolerance	Rated Voltage (VDC)	Size Code	Number of Leads per Side	Packaging
Dual In-Line, Metallized Polyester	10 15	First two digits indicate the two most significant digits of the capacitance value in picofarads. The third digit is the number of following zeros.	J = $\pm$ 5 K = $\pm$ 10% Other tolerances on request.	50 100 250 400 630	See Dimension Table	P3 = 3 leads P4 = 4 leads P5 = 5 leads P7 = 7 leads P8 = 8 leads	See Ordering Options Table

## New KEMET Part Number System

F	15	3	A	A	333	K	050	T
Capacitor Class	Series	Number of Leads per Side	Lead Spacing (mm)	Size Code	Capacitance Code (pF)	Capacitance Tolerance	Rated Voltage (VDC)	Packaging
F = Film	Dual In-line, Metallized Polyester	3 = 3 leads 4 = 4 leads 5 = 5 leads 7 = 7 leads 8 = 8 leads	A = 10 B = 15	A = Standard box size	First two digits indicate the two most significant digits of the capacitance value in picofarads. The third digit is the number of following zeros.	J = $\pm$ 5 K = $\pm$ 10% Other tolerances on request	050 = 50 100 = 100 250 = 250 400 = 400 630 = 630	See Ordering Options Table

## Ordering Options Table

Packaging Type		KEMET Packaging Code	Legacy Packaging Code
Standard Packaging Options			
Bulk (Tube)		T	TUBE
Case Size A53	Tape & Reel (Standard Reel)	VV687	TR32

## Dimensions – Millimeters

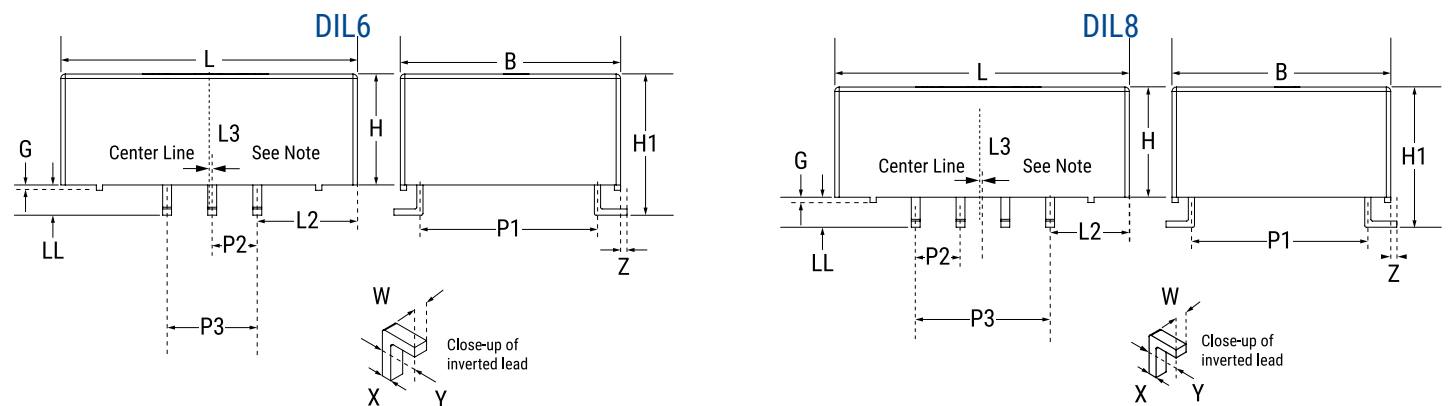

Legacy Size Code	Leads per Side	P1	P2	P3 <sup>(1)</sup>	B	H	L	H1	L2	L3 <sup>(2)</sup>	W	X	Y	Z	LL	G
		±0.2	±0.2	±0.2	±0.2	±0.2	±0.2	±0.2	±0.4	±0.2	Maximum	±0.05	±0.05	±0.2	Nominal	±0.2
A52	3	10.0	2.54	5.08	12.2	6.05	11.0	7.75	2.96	0.2	0.5	0.35	1.5	0.25	1.7	0.3
A53	3	10.0	2.54	5.08	12.7	9.00	14.0	10.5	4.46	0.2	0.5	0.35	1.5	0	1.5	0.3
A54	3	10.0	2.54	5.08	12.2	6.05	13.5	7.75	4.21	0.2	0.5	0.35	1.5	0.25	1.7	0.3
A55	3	10.0	2.54	5.08	12.2	6.05	16.5	7.75	5.71	0.2	0.5	0.35	1.5	0.25	1.7	0.3
B53	3	15.0	2.54	5.08	16.5	6.05	11.0	7.75	2.96	0.2	0.5	0.35	1.5	0.6	1.7	0.3
B55	3	15.0	2.54	5.08	16.5	6.05	12.2	7.75	3.56	0.2	0.5	0.35	1.5	0.6	1.7	0.3
A53	4	10.0	2.54	7.62	12.7	9.00	14.0	10.5	3.19	0.2	0.5	0.35	1.5	0	1.5	0.3
A54	4	10.0	2.54	7.62	12.2	6.05	13.5	7.75	2.94	0.2	0.5	0.35	1.5	0.25	1.7	0.3
A55	4	10.0	2.54	7.62	12.2	6.05	16.5	7.75	4.44	0.2	0.5	0.35	1.5	0.25	1.7	0.3
B55	4	15.0	2.54	7.62	16.5	6.05	12.2	7.75	2.29	0.2	0.5	0.35	1.5	0.6	1.7	0.3
A55	5	10.0	2.54	10.16	12.2	6.05	16.5	7.75	3.17	0.2	0.5	0.35	1.5	0.25	1.7	0.3
A58	7	10.0	2.54	15.24	12.7	11.0	23.0	12.5	3.88	0.2	0.5	0.35	1.5	0	1.5	0.3
A58	8	10.0	2.54	17.78	12.7	11.0	23.00	12.5	2.61	0.2	0.5	0.35	1.5	0	1.5	0.3

(1) P3 represents the cumulative tolerance of all leads.

(2) L3 represents the extent to which the center line of the leads misaligns with the center line of the body. Dimension shown is the maximum such misalignment allowed.

## Dimensions – Millimeters cont.

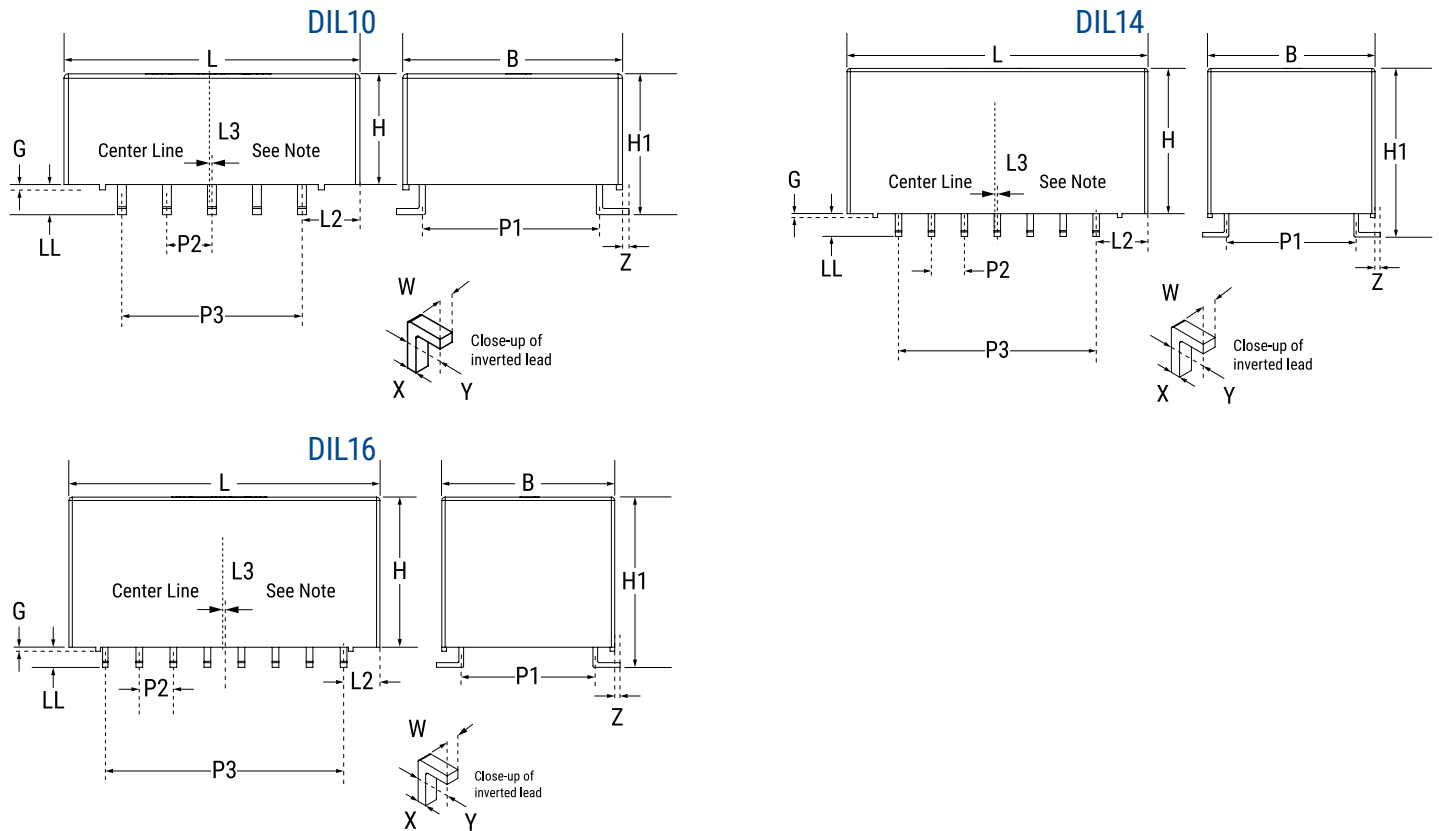

Legacy Size Code	Leads per Side	P1	P2	P3 <sup>(1)</sup>	B	H	L	H1	L2	L3 <sup>(2)</sup>	W	X	Y	Z	LL	G
		±0.2	±0.2	±0.2	±0.2	±0.2	±0.2	±0.2	±0.4	±0.2	Maximum	±0.05	±0.05	±0.2	Nominal	±0.2
A52	3	10.0	2.54	5.08	12.2	6.05	11.0	7.75	2.96	0.2	0.5	0.35	1.5	0.25	1.7	0.3
A53	3	10.0	2.54	5.08	12.7	9.00	14.0	10.5	4.46	0.2	0.5	0.35	1.5	0	1.5	0.3
A54	3	10.0	2.54	5.08	12.2	6.05	13.5	7.75	4.21	0.2	0.5	0.35	1.5	0.25	1.7	0.3
A55	3	10.0	2.54	5.08	12.2	6.05	16.5	7.75	5.71	0.2	0.5	0.35	1.5	0.25	1.7	0.3
B53	3	15.0	2.54	5.08	16.5	6.05	11.0	7.75	2.96	0.2	0.5	0.35	1.5	0.6	1.7	0.3
B55	3	15.0	2.54	5.08	16.5	6.05	12.2	7.75	3.56	0.2	0.5	0.35	1.5	0.6	1.7	0.3
A53	4	10.0	2.54	7.62	12.7	9.00	14.0	10.5	3.19	0.2	0.5	0.35	1.5	0	1.5	0.3
A54	4	10.0	2.54	7.62	12.2	6.05	13.5	7.75	2.94	0.2	0.5	0.35	1.5	0.25	1.7	0.3
A55	4	10.0	2.54	7.62	12.2	6.05	16.5	7.75	4.44	0.2	0.5	0.35	1.5	0.25	1.7	0.3
B55	4	15.0	2.54	7.62	16.5	6.05	12.2	7.75	2.29	0.2	0.5	0.35	1.5	0.6	1.7	0.3
A55	5	10.0	2.54	10.16	12.2	6.05	16.5	7.75	3.17	0.2	0.5	0.35	1.5	0.25	1.7	0.3
A58	7	10.0	2.54	15.24	12.7	11.0	23.0	12.5	3.88	0.2	0.5	0.35	1.5	0	1.5	0.3
A58	8	10.0	2.54	17.78	12.7	11.0	23.00	12.5	2.61	0.2	0.5	0.35	1.5	0	1.5	0.3

(1) P3 represents the cumulative tolerance of all leads.

(2) L3 represents the extent to which the center line of the leads misaligns with the center line of the body. Dimension shown is the maximum such misalignment allowed.

## Performance Characteristics

Rated Voltage (VDC)	50	100	250	400	630
Rated Voltage (VAC)	30	63	160	200	220
Capacitance Range (µF)	0.033 – 15	0.033 – 10	0.033 – 1.5	0.033 – 0.47	0.033 – 0.18
Capacitance Tolerance	±5%, ±10%, other tolerances on request				
Category Temperature Range	-55°C to +125°C				
Rated Temperature	+85°C				
Voltage Derating	The rated voltage is decreased with 1.25%/°C from +85°C				
Climatic Category	55/125/56				
Test Voltage	1.6 x V <sub>R</sub> 60 seconds				
Insulation Resistance	Measured at +20°C According to IEC 60384-2				
	Minimum Value Between Terminals				
		C ≤ 0.33 µF		C > 0.33 µF	
	V <sub>R</sub> ≤ 100	15,000 MΩ		5,000 MΩ · µF	
	V <sub>R</sub> > 100	30,000 MΩ		10,000 MΩ · µF	
Dissipation Factor	Maximum Values at +23°C				
		C ≤ 0.1 µF	0.1 < C < 3.3 µF	3.3 ≤ C ≤ 10 µF	C > 10 µF
	1 kHz	0.8%	0.8%	0.8%	0.8%
	10 kHz	1.5%	1.5%	1.5%	2.0%
	100 kHz	2.5%	5.0%		
Self Inductance	Approximately 4 nH				

## Maximum $V_{rms}$ vs. Frequency (Sinusoidal Waveform/Th $\leq 40^{\circ}\text{C}$ )

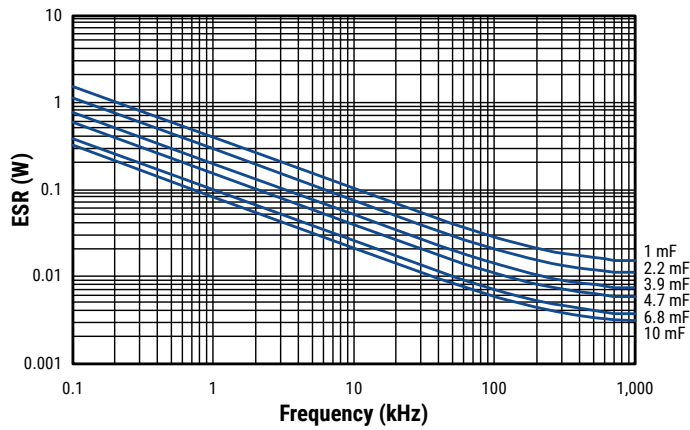

## Maximum $I_{rms}$ vs. Frequency (Sinusoidal Waveform/Th $\leq 40^{\circ}\text{C}$ )

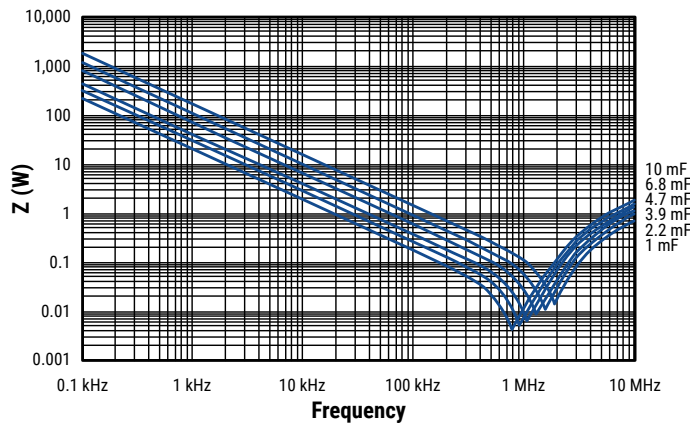

## Environmental Compliance

All KEMET surface mount capacitors are RoHS compliant.



**Table 1 – Ratings & Part Number Reference**

VDC	VAC	Cap Value (µF)	Size Code (New/Legacy)	Dimensions in mm			Lead Spacing (p)	ESR 500 kHz (mΩ)	New KEMET Part Number	Legacy Part Number
				B	H	L				
50	30	0.033	AA/A52	12.2	6.05	11.0	10	390	F153AA333(1)050T	MDC10333(1)50A52P3TUBE
50	30	0.039	AA/A52	12.2	6.05	11.0	10	330	F153AA393(1)050T	MDC10393(1)50A52P3TUBE
50	30	0.047	AA/A52	12.2	6.05	11.0	10	270	F153AA473(1)050T	MDC10473(1)50A52P3TUBE
50	30	0.056	AA/A52	12.2	6.05	11.0	10	230	F153AA563(1)050T	MDC10563(1)50A52P3TUBE
50	30	0.068	AA/A52	12.2	6.05	11.0	10	190	F153AA683(1)050T	MDC10683(1)50A52P3TUBE
50	30	0.082	AA/A52	12.2	6.05	11.0	10	160	F153AA823(1)050T	MDC10823(1)50A52P3TUBE
50	30	0.10	AA/A52	12.2	6.05	11.0	10	130	F153AA104(1)050T	MDC10104(1)50A52P3TUBE
50	30	0.12	AA/A52	12.2	6.05	11.0	10	110	F153AA124(1)050T	MDC10124(1)50A52P3TUBE
50	30	0.15	AA/A52	12.2	6.05	11.0	10	85	F153AA154(1)050T	MDC10154(1)50A52P3TUBE
50	30	0.18	AA/A52	12.2	6.05	11.0	10	70	F153AA184(1)050T	MDC10184(1)50A52P3TUBE
50	30	0.22	AA/A52	12.2	6.05	11.0	10	58	F153AA224(1)050T	MDC10224(1)50A52P3TUBE
50	30	0.27	AA/A52	12.2	6.05	11.0	10	47	F153AA274(1)050T	MDC10274(1)50A52P3TUBE
50	30	0.33	AA/A52	12.2	6.05	11.0	10	39	F153AA334(1)050T	MDC10334(1)50A52P3TUBE
50	30	0.39	AA/A52	12.2	6.05	11.0	10	33	F153AA394(1)050T	MDC10394(1)50A52P3TUBE
50	30	0.47	AA/A52	12.2	6.05	11.0	10	30	F153AA474(1)050T	MDC10474(1)50A52P3TUBE
50	30	0.56	AA/A52	12.2	6.05	11.0	10	26	F153AA564(1)050T	MDC10564(1)50A52P3TUBE
50	30	0.68	AA/A52	12.2	6.05	11.0	10	21	F153AA684(1)050T	MDC10684(1)50A52P3TUBE
50	30	0.82	AA/A52	12.2	6.05	11.0	10	18	F153AA824(1)050T	MDC10824(1)50A52P3TUBE
50	30	1.0	AA/A52	12.2	6.05	11.0	10	15	F153AA105(1)050T	MDC10105(1)50A52P3TUBE
50	30	1.2	AA/A52	12.2	6.05	11.0	10	14	F153AA125(1)050T	MDC10125(1)50A52P3TUBE
50	30	1.5	AA/A52	12.2	6.05	11.0	10	13	F153AA155(1)050T	MDC10155(1)50A52P3TUBE
50	30	1.8	AA/A52	12.2	6.05	11.0	10	12	F153AA185(1)050T	MDC10185(1)50A52P3TUBE
50	30	2.2	AA/A52	12.2	6.05	11.0	10	11	F153AA225(1)050T	MDC10225(1)50A52P3TUBE
50	30	2.7	AA/A52	12.2	6.05	11.0	10	10	F153AA275(1)050T	MDC10275(1)50A52P3TUBE
50	30	3.3	AA/A52	12.2	6.05	11.0	10	8	F153AA335(1)050T	MDC10335(1)50A52P3TUBE
50	30	3.9	AA/A52	12.2	6.05	11.0	10	7	F153AA395(1)050T	MDC10395(1)50A52P3TUBE
50	30	4.7	AA/A52	12.2	6.05	11.0	10	6	F153AA475(1)050T	MDC10475(1)50A52P3TUBE
50	30	5.6	AA/A54	12.2	6.05	13.5	10	5	F15(2)AA565(1)050T	MDC10565(1)50A54P(2)TUBE
50	30	6.8	AA/A55	12.2	6.05	16.5	10	5	F15(3)AA685(1)050T	MDC10685(1)50A55P(3)TUBE
50	30	8.2	AA/A58	12.7	11.0	23.0	10	4	F15(4)AA685(1)050T	MDC10825(1)50A58P(4)TUBE
50	30	10	AA/A58	12.7	11.0	23.0	10	3	F15(4)AA106(1)050T	MDC10106(1)50A58P(4)TUBE
50	30	12	AA/A58	12.7	11.0	23.0	10	3	F15(4)AA126(1)050T	MDC10126(1)50A58P(4)TUBE
50	30	15	AA/A58	12.7	11.0	23.0	10	3	F15(4)AA156(1)050T	MDC10156(1)50A58P(4)TUBE
50	30	0.033	BA/B53	16.5	6.05	11.0	15	390	F153BA333(1)050T	MDC15333(1)50B53P3TUBE
50	30	0.039	BA/B53	16.5	6.05	11.0	15	330	F153BA393(1)050T	MDC15393(1)50B53P3TUBE
50	30	0.047	BA/B53	16.5	6.05	11.0	15	270	F153BA473(1)050T	MDC15473(1)50B53P3TUBE
50	30	0.056	BA/B53	16.5	6.05	11.0	15	230	F153BA563(1)050T	MDC15563(1)50B53P3TUBE
50	30	0.068	BA/B53	16.5	6.05	11.0	15	190	F153BA683(1)050T	MDC15683(1)50B53P3TUBE
50	30	0.082	BA/B53	16.5	6.05	11.0	15	160	F153BA823(1)050T	MDC15823(1)50B53P3TUBE
50	30	0.10	BA/B53	16.5	6.05	11.0	15	130	F153BA104(1)050T	MDC15104(1)50B53P3TUBE
50	30	0.12	BA/B53	16.5	6.05	11.0	15	110	F153BA124(1)050T	MDC15124(1)50B53P3TUBE
50	30	0.15	BA/B53	16.5	6.05	11.0	15	85	F153BA154(1)050T	MDC15154(1)50B53P3TUBE
50	30	0.18	BA/B53	16.5	6.05	11.0	15	70	F153BA184(1)050T	MDC15184(1)50B53P3TUBE
50	30	0.22	BA/B53	16.5	6.05	11.0	15	58	F153BA224(1)050T	MDC15224(1)50B53P3TUBE
50	30	0.27	BA/B53	16.5	6.05	11.0	15	47	F153BA274(1)050T	MDC15274(1)50B53P3TUBE
50	30	0.33	BA/B53	16.5	6.05	11.0	15	39	F153BA334(1)050T	MDC15334(1)50B53P3TUBE
50	30	0.39	BA/B53	16.5	6.05	11.0	15	39	F153BA394(1)050T	MDC15394(1)50B53P3TUBE
50	30	0.47	BA/B53	16.5	6.05	11.0	15	30	F153BA474(1)050T	MDC15474(1)50B53P3TUBE
50	30	0.56	BA/B53	16.5	6.05	11.0	15	26	F153BA564(1)050T	MDC15564(1)50B53P3TUBE
50	30	0.68	BA/B53	16.5	6.05	11.0	15	21	F153BA684(1)050T	MDC15684(1)50B53P3TUBE
50	30	0.82	BA/B53	16.5	6.05	11.0	15	18	F153BA824(1)050T	MDC15824(1)50B53P3TUBE
50	30	1.0	BA/B53	16.5	6.05	11.0	15	15	F153BA105(1)050T	MDC15105(1)50B53P3TUBE
50	30	1.2	BA/B53	16.5	6.05	11.0	15	15	F153BA125(1)050T	MDC15125(1)50B53P3TUBE
50	30	1.5	BA/B53	16.5	6.05	11.0	15	13	F153BA155(1)050T	MDC15155(1)50B53P3TUBE
50	30	1.8	BA/B53	16.5	6.05	11.0	15	13	F153BA185(1)050T	MDC15185(1)50B53P3TUBE
50	30	2.2	BA/B53	16.5	6.05	11.0	15	11	F153BA225(1)050T	MDC15225(1)50B53P3TUBE
50	30	2.7	BA/B53	16.5	6.05	11.0	15	11	F153BA275(1)050T	MDC15275(1)50B53P3TUBE
VDC	VAC	Cap Value (µF)	Size Code (New/Legacy)	B (mm)	H (mm)	L (mm)	Lead Spacing (p)	ESR 500 kHz (mΩ)	New KEMET Part Number	Legacy Part Number

(1) J = ±5%, K = ±10%, other tolerances on request.

(2) = Number of leads per side, 3 or 4.

(3) = Number of leads per side, 3, 4 or 5.

(4) = Number of leads per side, 7 or 8.

**Table 1 – Ratings & Part Number Reference cont.**

VDC	VAC	Cap Value (µF)	Size Code (New/Legacy)	Dimensions in mm			Lead Spacing (p)	ESR 500 kHz (mΩ)	New KEMET Part Number	Legacy Part Number
				B	H	L				
50	30	3.3	BA/B53	16.5	6.05	11.0	15	8	F153BA335(1)050T	MDC15335(1)50B53P3TUBE
50	30	3.9	BA/B53	16.5	6.05	11.0	15	8	F153BA395(1)050T	MDC15395(1)50B53P3TUBE
50	30	4.7	BA/B53	16.5	6.05	11.0	15	6	F153BA475(1)050T	MDC15475(1)50B53P3TUBE
50	30	5.6	BA/B53	16.5	6.05	11.0	15	5	F153BA565(1)050T	MDC15565(1)50B53P3TUBE
50	30	6.8	BA/B53	16.5	6.05	11.0	15	5	F153BA685(1)050T	MDC15685(1)50B53P3TUBE
100	63	0.033	AA/A52	12.2	6.05	11.0	10	390	F153AA333(1)100T	MDC10333(1)100A52P3TUBE
100	63	0.039	AA/A52	12.2	6.05	11.0	10	330	F153AA393(1)100T	MDC10393(1)100A52P3TUBE
100	63	0.047	AA/A52	12.2	6.05	11.0	10	270	F153AA473(1)100T	MDC10473(1)100A52P3TUBE
100	63	0.056	AA/A52	12.2	6.05	11.0	10	230	F153AA563(1)100T	MDC10563(1)100A52P3TUBE
100	63	0.068	AA/A52	12.2	6.05	11.0	10	190	F153AA683(1)100T	MDC10683(1)100A52P3TUBE
100	63	0.082	AA/A52	12.2	6.05	11.0	10	160	F153AA823(1)100T	MDC10823(1)100A52P3TUBE
100	63	0.10	AA/A52	12.2	6.05	11.0	10	130	F153AA104(1)100T	MDC10104(1)100A52P3TUBE
100	63	0.12	AA/A52	12.2	6.05	11.0	10	110	F153AA124(1)100T	MDC10124(1)100A52P3TUBE
100	63	0.15	AA/A52	12.2	6.05	11.0	10	85	F153AA154(1)100T	MDC10154(1)100A52P3TUBE
100	63	0.18	AA/A52	12.2	6.05	11.0	10	70	F153AA184(1)100T	MDC10184(1)100A52P3TUBE
100	63	0.22	AA/A52	12.2	6.05	11.0	10	58	F153AA224(1)100T	MDC10224(1)100A52P3TUBE
100	63	0.27	AA/A52	12.2	6.05	11.0	10	47	F153AA274(1)100T	MDC10274(1)100A52P3TUBE
100	63	0.33	AA/A52	12.2	6.05	11.0	10	39	F153AA334(1)100T	MDC10334(1)100A52P3TUBE
100	63	0.39	AA/A52	12.2	6.05	11.0	10	33	F153AA394(1)100T	MDC10394(1)100A52P3TUBE
100	63	0.47	AA/A52	12.2	6.05	11.0	10	30	F153AA474(1)100T	MDC10474(1)100A52P3TUBE
100	63	0.56	AA/A52	12.2	6.05	11.0	10	26	F153AA564(1)100T	MDC10564(1)100A52P3TUBE
100	63	0.68	AA/A52	12.2	6.05	11.0	10	21	F153AA684(1)100T	MDC10684(1)100A52P3TUBE
100	63	0.82	AA/A52	12.2	6.05	11.0	10	18	F153AA824(1)100T	MDC10824(1)100A52P3TUBE
100	63	1.0	AA/A52	12.2	6.05	11.0	10	15	F153AA105(1)100T	MDC10105(1)100A52P3TUBE
100	63	1.2	AA/A52	12.2	6.05	11.0	10	14	F153AA125(1)100T	MDC10125(1)100A52P3TUBE
100	63	1.5	AA/A52	12.2	6.05	11.0	10	13	F153AA155(1)100T	MDC10155(1)100A52P3TUBE
100	63	1.8	AA/A52	12.2	6.05	11.0	10	12	F153AA185(1)100T	MDC10185(1)100A52P3TUBE
100	63	2.2	AA/A52	12.2	6.05	11.0	10	11	F153AA225(1)100T	MDC10225(1)100A52P3TUBE
100	35	2.7	AA/A52	12.2	6.05	11.0	10	10	F153AA275(1)100T	MDC10275(1)100A52P3TUBE
100	35	3.3	AA/A52	12.2	6.05	11.0	10	8	F153AA335(1)100T	MDC10335(1)100A52P3TUBE
100	35	3.9	AA/A52	12.2	6.05	11.0	10	7	F153AA395(1)100T	MDC10395(1)100A52P3TUBE
100	35	4.7	AA/A54	12.2	6.05	13.5	10	6	F15(2)AA475(1)100T	MDC10475(1)100A54P(2)TUBE
100	35	4.7	AA/A53	12.7	9.0	14.0	10	6	F15(2)AA475(1)100V687	MDC10475(1)100A53P(2)TR32
100	35	5.6	AA/A55	12.2	6.05	16.5	10	5	F15(3)AA565(1)100T	MDC10565(1)100A55P(3)TUBE
100	63	6.8	AA/A58	12.7	11.0	23.0	10	5	F15(4)AA685(1)100T	MDC10685(1)100A58P(4)TUBE
100	63	8.2	AA/A58	12.7	11.0	23.0	10	4	F15(4)AA825(1)100T	MDC10825(1)100A58P(4)TUBE
100	63	10	AA/A58	12.7	11.0	23.0	10	3	F15(4)AA106(1)100T	MDC10106(1)100A58P(4)TUBE
100	63	0.033	BA/B53	16.5	6.05	11.0	15	390	F153BA333(1)100T	MDC15333(1)100B53P3TUBE
100	63	0.039	BA/B53	16.5	6.05	11.0	15	330	F153BA393(1)100T	MDC15393(1)100B53P3TUBE
100	63	0.047	BA/B53	16.5	6.05	11.0	15	270	F153BA473(1)100T	MDC15473(1)100B53P3TUBE
100	63	0.056	BA/B53	16.5	6.05	11.0	15	230	F153BA563(1)100T	MDC15563(1)100B53P3TUBE
100	63	0.068	BA/B53	16.5	6.05	11.0	15	190	F153BA683(1)100T	MDC15683(1)100B53P3TUBE
100	63	0.082	BA/B53	16.5	6.05	11.0	15	160	F153BA823(1)100T	MDC15823(1)100B53P3TUBE
100	63	0.10	BA/B53	16.5	6.05	11.0	15	130	F153BA104(1)100T	MDC15104(1)100B53P3TUBE
100	63	0.12	BA/B53	16.5	6.05	11.0	15	110	F153BA124(1)100T	MDC15124(1)100B53P3TUBE
100	63	0.15	BA/B53	16.5	6.05	11.0	15	85	F153BA154(1)100T	MDC15154(1)100B53P3TUBE
100	63	0.18	BA/B53	16.5	6.05	11.0	15	70	F153BA184(1)100T	MDC15184(1)100B53P3TUBE
100	63	0.22	BA/B53	16.5	6.05	11.0	15	58	F153BA224(1)100T	MDC15224(1)100B53P3TUBE
100	63	0.27	BA/B53	16.5	6.05	11.0	15	47	F153BA274(1)100T	MDC15274(1)100B53P3TUBE
100	63	0.33	BA/B53	16.5	6.05	11.0	15	39	F153BA334(1)100T	MDC15334(1)100B53P3TUBE
100	63	0.39	BA/B53	16.5	6.05	11.0	15	39	F153BA394(1)100T	MDC15394(1)100B53P3TUBE
100	63	0.47	BA/B53	16.5	6.05	11.0	15	30	F153BA474(1)100T	MDC15474(1)100B53P3TUBE
100	63	0.56	BA/B53	16.5	6.05	11.0	15	26	F153BA564(1)100T	MDC15564(1)100B53P3TUBE
100	63	0.68	BA/B53	16.5	6.05	11.0	15	21	F153BA684(1)100T	MDC15684(1)100B53P3TUBE
100	63	0.82	BA/B53	16.5	6.05	11.0	15	18	F153BA824(1)100T	MDC15824(1)100B53P3TUBE
100	63	1.0	BA/B53	16.5	6.05	11.0	15	15	F153BA105(1)100T	MDC15105(1)100B53P3TUBE
100	63	1.2	BA/B53	16.5	6.05	11.0	15	15	F153BA125(1)100T	MDC15125(1)100B53P3TUBE
VDC	VAC	Cap Value (µF)	Size Code (New/Legacy)	B (mm)	H (mm)	L (mm)	Lead Spacing (p)	ESR 500 kHz (mΩ)	New KEMET Part Number	Legacy Part Number

(1) J = ±5%, K = ±10%, other tolerances on request.

(2) = Number of leads per side, 3 or 4.

(3) = Number of leads per side, 3, 4 or 5.

(4) = Number of leads per side, 7 or 8.

**Table 1 – Ratings & Part Number Reference cont.**

VDC	VAC	Cap Value (µF)	Size Code (New/Legacy)	Dimensions in mm			Lead Spacing (p)	ESR 500 kHz (mΩ)	New KEMET Part Number	Legacy Part Number
				B	H	L				
100	63	1.5	BA/B53	16.5	6.05	11.0	15	13	F153BA155(1)100T	MDC15155(1)100B53P3TUBE
100	63	1.8	BA/B53	16.5	6.05	11.0	15	13	F153BA185(1)100T	MDC15185(1)100B53P3TUBE
100	63	2.2	BA/B53	16.5	6.05	11.0	15	11	F153BA225(1)100T	MDC15225(1)100B53P3TUBE
100	63	2.7	BA/B53	16.5	6.05	11.0	15	11	F153BA275(1)100T	MDC15275(1)100B53P3TUBE
100	63	3.3	BA/B53	16.5	6.05	11.0	15	8	F153BA335(1)100T	MDC15335(1)100B53P3TUBE
100	63	3.9	BA/B53	16.5	6.05	11.0	15	8	F153BA395(1)100T	MDC15395(1)100B53P3TUBE
100	35	4.7	BA/B53	16.5	6.05	11.0	15	6	F153BA475(1)100T	MDC15475(1)100B53P3TUBE
100	63	5.6	BA/B55	16.5	6.05	12.2	15	5	F15(2)BA565(1)100T	MDC15565(1)100B55P(2)TUBE
250	160	0.033	AA/A52	12.2	6.05	11.0	10	390	F153AA333(1)250T	MDC10333(1)250A52P3TUBE
250	160	0.039	AA/A52	12.2	6.05	11.0	10	330	F153AA393(1)250T	MDC10393(1)250A52P3TUBE
250	160	0.047	AA/A52	12.2	6.05	11.0	10	270	F153AA473(1)250T	MDC10473(1)250A52P3TUBE
250	160	0.056	AA/A52	12.2	6.05	11.0	10	230	F153AA563(1)250T	MDC10563(1)250A52P3TUBE
250	160	0.068	AA/A52	12.2	6.05	11.0	10	190	F153AA683(1)250T	MDC10683(1)250A52P3TUBE
250	160	0.082	AA/A52	12.2	6.05	11.0	10	160	F153AA823(1)250T	MDC10823(1)250A52P3TUBE
250	160	0.10	AA/A52	12.2	6.05	11.0	10	130	F153AA104(1)250T	MDC10104(1)250A52P3TUBE
250	160	0.12	AA/A52	12.2	6.05	11.0	10	130	F153AA124(1)250T	MDC10124(1)250A52P3TUBE
250	160	0.15	AA/A52	12.2	6.05	11.0	10	130	F153AA154(1)250T	MDC10154(1)250A52P3TUBE
250	160	0.18	AA/A52	12.2	6.05	11.0	10	70	F153AA184(1)250T	MDC10184(1)250A52P3TUBE
250	160	0.22	AA/A52	12.2	6.05	11.0	10	58	F153AA224(1)250T	MDC10224(1)250A52P3TUBE
250	160	0.27	AA/A52	12.2	6.05	11.0	10	47	F153AA274(1)250T	MDC10274(1)250A52P3TUBE
250	160	0.33	AA/A52	12.2	6.05	11.0	10	39	F153AA334(1)250T	MDC10334(1)250A52P3TUBE
250	160	0.39	AA/A52	12.2	6.05	11.0	10	33	F153AA394(1)250T	MDC10394(1)250A52P3TUBE
250	160	0.47	AA/A52	12.2	6.05	11.0	10	30	F153AA474(1)250T	MDC10474(1)250A52P3TUBE
250	160	0.56	AA/A54	12.2	6.05	13.5	10	26	F15(2)AA564(1)250T	MDC10564(1)250A54P(2)TUBE
250	160	0.68	AA/A55	12.2	6.05	16.5	10	21	F15(3)AA684(1)250T	MDC10684(1)250A55P(3)TUBE
250	160	0.82	AA/A58	12.7	11.0	23.0	10	18	F15(4)AA824(1)250T	MDC10824(1)250A58P(4)TUBE
250	160	1.0	AA/A58	12.7	11.0	23.0	10	15	F15(4)AA105(1)250T	MDC10105(1)250A58P(4)TUBE
250	160	1.2	AA/A58	12.7	11.0	23.0	10	14	F15(4)AA125(1)250T	MDC10125(1)250A58P(4)TUBE
250	160	1.5	AA/A58	12.7	11.0	23.0	10	13	F15(4)AA155(1)250T	MDC10155(1)250A58P(4)TUBE
250	160	0.033	BA/B53	16.5	6.05	11.0	15	390	F153BA333(1)250T	MDC15333(1)250B53P3TUBE
250	160	0.039	BA/B53	16.5	6.05	11.0	15	330	F153BA393(1)250T	MDC15393(1)250B53P3TUBE
250	160	0.047	BA/B53	16.5	6.05	11.0	15	270	F153BA473(1)250T	MDC15473(1)250B53P3TUBE
250	160	0.056	BA/B53	16.5	6.05	11.0	15	230	F153BA563(1)250T	MDC15563(1)250B53P3TUBE
250	160	0.068	BA/B53	16.5	6.05	11.0	15	190	F153BA683(1)250T	MDC15683(1)250B53P3TUBE
250	160	0.082	BA/B53	16.5	6.05	11.0	15	160	F153BA823(1)250T	MDC15823(1)250B53P3TUBE
250	160	0.10	BA/B53	16.5	6.05	11.0	15	130	F153BA104(1)250T	MDC15104(1)250B53P3TUBE
250	160	0.12	BA/B53	16.5	6.05	11.0	15	110	F153BA124(1)250T	MDC15124(1)250B53P3TUBE
250	160	0.15	BA/B53	16.5	6.05	11.0	15	85	F153BA154(1)250T	MDC15154(1)250B53P3TUBE
250	160	0.18	BA/B53	16.5	6.05	11.0	15	70	F153BA184(1)250T	MDC15184(1)250B53P3TUBE
250	160	0.22	BA/B53	16.5	6.05	11.0	15	58	F153BA224(1)250T	MDC15224(1)250B53P3TUBE
250	160	0.27	BA/B53	16.5	6.05	11.0	15	47	F153BA274(1)250T	MDC15274(1)250B53P3TUBE
250	160	0.33	BA/B53	16.5	6.05	11.0	15	39	F153BA334(1)250T	MDC15334(1)250B53P3TUBE
250	160	0.39	BA/B53	16.5	6.05	11.0	15	39	F153BA394(1)250T	MDC15394(1)250B53P3TUBE
250	160	0.47	BA/B53	16.5	6.05	11.0	15	30	F153BA474(1)250T	MDC15474(1)250B53P3TUBE
250	160	0.56	BA/B53	16.5	6.05	11.0	15	26	F153BA564(1)250T	MDC15564(1)250B53P3TUBE
250	160	0.68	BA/B53	16.5	6.05	11.0	15	21	F153BA684(1)250T	MDC15684(1)250B53P3TUBE
400	200	0.033	AA/A52	12.2	6.05	11.0	10	390	F153AA333(1)400T	MDC10333(1)400A52P3TUBE
400	200	0.039	AA/A52	12.2	6.05	11.0	10	330	F153AA393(1)400T	MDC10393(1)400A52P3TUBE
400	200	0.047	AA/A52	12.2	6.05	11.0	10	270	F153AA473(1)400T	MDC10473(1)400A52P3TUBE
400	200	0.056	AA/A52	12.2	6.05	11.0	10	230	F153AA563(1)400T	MDC10563(1)400A52P3TUBE
400	200	0.068	AA/A52	12.2	6.05	11.0	10	190	F153AA683(1)400T	MDC10683(1)400A52P3TUBE
400	200	0.082	AA/A52	12.2	6.05	11.0	10	160	F153AA823(1)400T	MDC10823(1)400A52P3TUBE
400	200	0.10	AA/A52	12.2	6.05	11.0	10	130	F153AA104(1)400T	MDC10104(1)400A52P3TUBE
400	200	0.12	AA/A52	12.2	6.05	11.0	10	110	F153AA124(1)400T	MDC10124(1)400A52P3TUBE
400	200	0.15	AA/A52	12.2	6.05	11.0	10	85	F153AA154(1)400T	MDC10154(1)400A52P3TUBE
400	200	0.18	AA/A52	12.2	6.05	11.0	10	70	F153AA184(1)400T	MDC10184(1)400A52P3TUBE
400	200	0.22	AA/A58	12.7	11.0	23.0	10	58	F15(4)AA224(1)400T	MDC10224(1)400A58P(4)TUBE
VDC	VAC	Cap Value (µF)	Size Code (New/Legacy)	B (mm)	H (mm)	L (mm)	Lead Spacing (p)	ESR 500 kHz (mΩ)	New KEMET Part Number	Legacy Part Number

(1) J = ±5%, K = ±10%, other tolerances on request.

(2) = Number of leads per side, 3 or 4.

(3) = Number of leads per side, 3, 4 or 5.

(4) = Number of leads per side, 7 or 8.



**Table 1 – Ratings & Part Number Reference cont.**

VDC	VAC	Cap Value (µF)	Size Code (New/Legacy)	Dimensions in mm			Lead Spacing (p)	ESR 500 kHz (mΩ)	New KEMET Part Number	Legacy Part Number
				B	H	L				
400	200	0.27	AA/A58	12.7	11.0	23.0	10	47	F15(4)AA274(1)400T	MDC10274(1)400A58P(4)TUBE
400	200	0.33	AA/A58	12.7	11.0	23.0	10	39	F15(4)AA334(1)400T	MDC10334(1)400A58P(4)TUBE
400	200	0.39	AA/A58	12.7	11.0	23.0	10	33	F15(4)AA394(1)400T	MDC10394(1)400A58P(4)TUBE
400	200	0.47	AA/A58	12.7	11.0	23.0	10	30	F15(4)AA474(1)400T	MDC10474(1)400A58P(4)TUBE
400	200	0.033	BA/B53	16.5	6.05	11.0	15	390	F153BA333(1)400T	MDC15333(1)400B53P3TUBE
400	200	0.039	BA/B53	16.5	6.05	11.0	15	330	F153BA393(1)400T	MDC15393(1)400B53P3TUBE
400	200	0.047	BA/B53	16.5	6.05	11.0	15	270	F153BA473(1)400T	MDC15473(1)400B53P3TUBE
400	200	0.056	BA/B53	16.5	6.05	11.0	15	230	F153BA563(1)400T	MDC15563(1)400B53P3TUBE
400	200	0.068	BA/B53	16.5	6.05	11.0	15	190	F153BA683(1)400T	MDC15683(1)400B53P3TUBE
400	200	0.082	BA/B53	16.5	6.05	11.0	15	160	F153BA823(1)400T	MDC15823(1)400B53P3TUBE
400	200	0.10	BA/B53	16.5	6.05	11.0	15	130	F153BA104(1)400T	MDC15104(1)400B53P3TUBE
400	200	0.12	BA/B53	16.5	6.05	11.0	15	110	F153BA124(1)400T	MDC15124(1)400B53P3TUBE
400	200	0.15	BA/B53	16.5	6.05	11.0	15	85	F153BA154(1)400T	MDC15154(1)400B53P3TUBE
400	200	0.18	BA/B53	16.5	6.05	11.0	15	70	F153BA184(1)400T	MDC15184(1)400B53P3TUBE
400	200	0.22	BA/B53	16.5	6.05	11.0	15	58	F153BA224(1)400T	MDC15224(1)400B53P3TUBE
400	200	0.27	BA/B53	16.5	6.05	11.0	15	47	F153BA274(1)400T	MDC15274(1)400B53P3TUBE
400	200	0.33	BA/B55	16.5	6.05	12.2	15	39	F15(2)BA334(1)400T	MDC15334(1)400B55P(2)TUBE
630	220	0.033	AA/A52	12.2	6.05	11.0	10	390	F153AA333(1)630T	MDC10333(1)630A52P3TUBE
630	220	0.039	AA/A52	12.2	6.05	11.0	10	330	F153AA393(1)630T	MDC10393(1)630A52P3TUBE
630	220	0.047	AA/A52	12.2	6.05	11.0	10	270	F153AA473(1)630T	MDC10473(1)630A52P3TUBE
630	220	0.056	AA/A52	12.2	6.05	11.0	10	230	F153AA563(1)630T	MDC10563(1)630A52P3TUBE
630	220	0.068	AA/A54	12.2	6.05	13.5	10	190	F15(2)AA683(1)630T	MDC10683(1)630A54P(2)TUBE
630	220	0.082	AA/A58	12.7	11.0	23.0	10	160	F15(4)AA823(1)630T	MDC10823(1)630A58P(4)TUBE
630	220	0.10	AA/A58	12.7	11.0	23.0	10	130	F15(4)AA104(1)630T	MDC10104(1)630A58P(4)TUBE
630	220	0.12	AA/A58	12.7	11.0	23.0	10	110	F15(4)AA124(1)630T	MDC10124(1)630A58P(4)TUBE
630	220	0.15	AA/A58	12.7	11.0	23.0	10	85	F15(4)AA154(1)630T	MDC10154(1)630A58P(4)TUBE
630	220	0.18	AA/A58	12.7	11.0	23.0	10	70	F15(4)AA184(1)630T	MDC10184(1)630A58P(4)TUBE
630	220	0.033	BA/B53	16.5	6.05	11.0	15	390	F153BA333(1)630T	MDC15333(1)630B53P3TUBE
630	220	0.039	BA/B53	16.5	6.05	11.0	15	330	F153BA393(1)630T	MDC15393(1)630B53P3TUBE
630	220	0.047	BA/B53	16.5	6.05	11.0	15	270	F153BA473(1)630T	MDC15473(1)630B53P3TUBE
630	220	0.056	BA/B53	16.5	6.05	11.0	15	230	F153BA563(1)630T	MDC15563(1)630B53P3TUBE
630	220	0.068	BA/B53	16.5	6.05	11.0	15	190	F153BA683(1)630T	MDC15683(1)630B53P3TUBE
630	220	0.082	BA/B53	16.5	6.05	11.0	15	160	F153BA823(1)630T	MDC15823(1)630B53P3TUBE
630	220	0.10	BA/B53	16.5	6.05	11.0	15	130	F153BA104(1)630T	MDC15104(1)630B53P3TUBE
VDC	VAC	Cap Value (µF)	Size Code (New/Legacy)	B (mm)	H (mm)	L (mm)	Lead Spacing (p)	ESR 500 kHz (mΩ)	New KEMET Part Number	Legacy Part Number

(1) J = ±5%, K = ±10%, other tolerances on request.

(2) = Number of leads per side, 3 or 4.

(3) = Number of leads per side, 3, 4 or 5.

(4) = Number of leads per side, 7 or 8.

## Soldering Process

**Reflow soldering temperature is measured on the top surface of the component:** Preheating temperature should be less than 170°C. The time above 217°C should be less than 50 seconds. The peak temperature must not exceed 240°C.

A lead-free soldering process for this series is in development. Please contact KEMET for details.

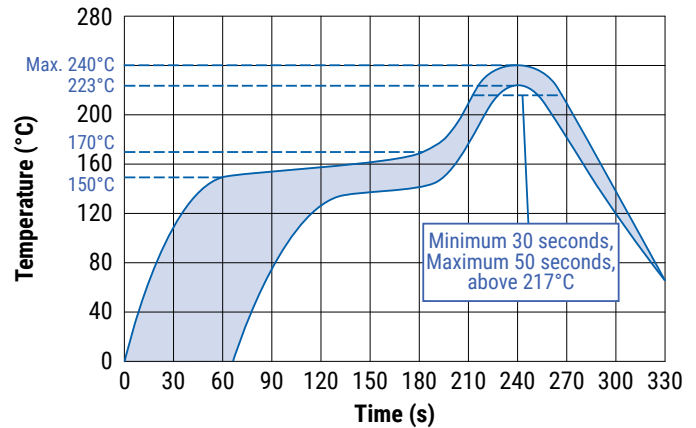

## Marking

- KEMET
- Capacitance
- Capacitance tolerance code
- Rated voltage
- Capacitor family code MDC

## Packaging Quantities

Size Code	Lead Spacing	Base (mm)	Height (mm)	Length (mm)	Bulk	Reel
A52	10.0	12.2	6.05	11.0	43	
A53		12.7	9.0	14.0	34	200
A54		12.2	6.05	13.5	35	
A55		12.2	6.05	16.5	28	
A58		12.7	11.0	23.0	21	
B53	15.0	16.5	6.05	11.0	43	
B55		16.5	6.05	12.2	39	

## Tube Packaging

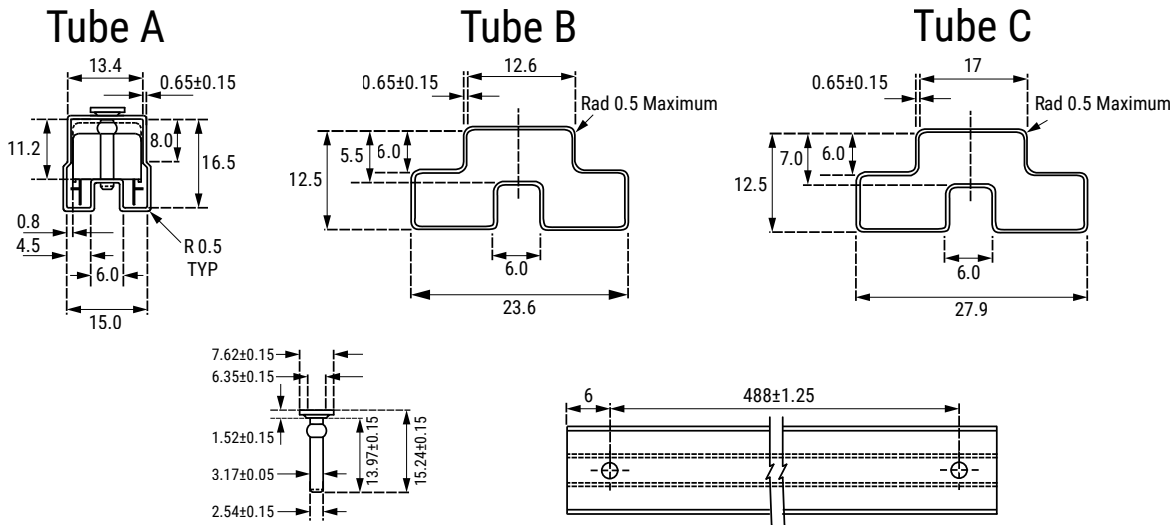

Size Code	Dimensions in mm	Tube
A52	10.0 – 12.2 x 6.05 x 11.0	Tube B
A53	10.0 – 12.7 x 9.0 x 14.0	Tube A
A54	10.0 – 12.2 x 6.05 x 13.5	Tube B
A55	10.0 – 12.2 x 6.05 x 16.5	Tube B
A58	10.0 – 12.7 x 11.0 x 23.0	Tube A
B53	15.0 – 16.5 x 6.05 x 11.0	Tube C
B55	15.0 – 16.5 x 6.05 x 12.2	Tube C

## Landing

Size	Dimensions in mm						
	p	A	B	C	D	E	F
A52	10	1	2	9.15	13.15	2.54	0.25
A53	10	1	2	9.15	13.15	2.54	0.25
A54	10	1	2	9.15	13.15	2.54	0.25
A55	10	1	2	9.15	13.15	2.54	0.25
A58	10	1	2	9.15	13.15	2.54	0.25
B53	15	1	2	14.15	18.15	2.54	0.25
B55	15	1	2	14.15	18.15	2.54	0.25

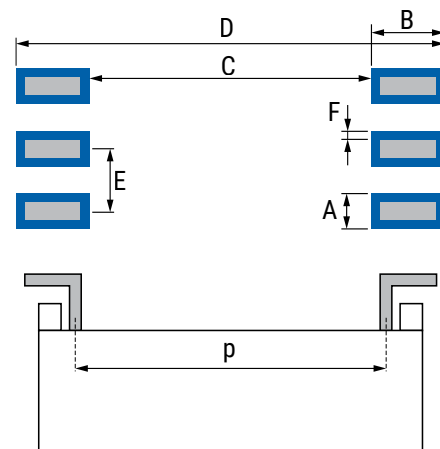

## KEMET Electronics Corporation Sales Offices

For a complete list of our global sales offices, please visit [www.kemet.com/sales](http://www.kemet.com/sales).

---

### Disclaimer

All product specifications, statements, information and data (collectively, the "Information") in this datasheet are subject to change. The customer is responsible for checking and verifying the extent to which the Information contained in this publication is applicable to an order at the time the order is placed. All Information given herein is believed to be accurate and reliable, but it is presented without guarantee, warranty, or responsibility of any kind, expressed or implied.

Statements of suitability for certain applications are based on KEMET Electronics Corporation's ("KEMET") knowledge of typical operating conditions for such applications, but are not intended to constitute – and KEMET specifically disclaims – any warranty concerning suitability for a specific customer application or use. The Information is intended for use only by customers who have the requisite experience and capability to determine the correct products for their application. Any technical advice inferred from this Information or otherwise provided by KEMET with reference to the use of KEMET's products is given gratis, and KEMET assumes no obligation or liability for the advice given or results obtained.

Although KEMET designs and manufactures its products to the most stringent quality and safety standards, given the current state of the art, isolated component failures may still occur. Accordingly, customer applications which require a high degree of reliability or safety should employ suitable designs or other safeguards (such as installation of protective circuitry or redundancies) in order to ensure that the failure of an electrical component does not result in a risk of personal injury or property damage.

Although all product-related warnings, cautions and notes must be observed, the customer should not assume that all safety measures are indicated or that other measures may not be required.

*KEMET is a registered trademark of KEMET Electronics Corporation.*

单击下面可查看定价，库存，交付和生命周期等信息

[>>KEMET\(基美\)](#)