

Overview

These electrolytic capacitors contain a radial crown, which allows them to be mounted in a standing position. They feature outstanding electrical performance, a polarized, all-welded design, tinned copper wire leads, and a negative pole connected to the case. The winding is housed in a cylindrical aluminium can with a high purity aluminium lid and a high quality rubber gasket. Low ESR is a result of a low resistive electrolyte/paper system and an all-welded design. Thanks to its mechanical robustness, these capacitors are suitable for use in mobile and aircraft installations, with operation up to +150°C. KEMET automotive grade capacitors meet the demanding Automotive Electronics Council's AEC-Q200 qualification requirements.

Applications

The KEMET PEH220, PEH225, and PEH226 are high performance electrolytic capacitors. They are designed for automotive applications with high demands for resistance to vibrations and high ambient temperature.

Benefits

- AEC-Q200 automotive qualified
- Up to 2,000 hours at +150°C
- Resistance to vibrations
- Resistance to high ambient temperature
- High ripple current
- Low ESR
- Polarized all-welded design
- Outstanding electrical performance
- Radial crown which allows mounting in a standing position

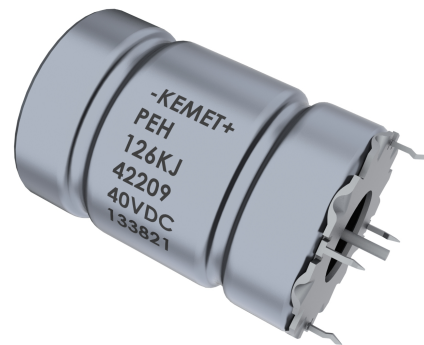

Part Number System

PEH220	H	F	415	0	M	E4
Series	Rated Voltage (VDC)	Size Code	Capacitance Code (pF)	Version	Capacitance Tolerance	Packaging
Radial Crown Aluminum Electrolytic with Soldering Star Termination	H = 25 K = 40 M = 63	See Dimension Table	The last two digits represent significant figures. The first digit indicates the total number digits.	0 = Standard (without shrink tape)	Q = -10 +30% M = ±20%	E4 = Tray

PEH225	H	F	422	0	M	E4
Series	Rated Voltage (VDC)	Size Code	Capacitance Code (pF)	Version	Capacitance Tolerance	Packaging
Radial Crown Aluminum Electrolytic with Soldering Star Termination	H = 25 K = 40 M = 63	See Dimension Table	The last two digits represent significant figures. The first digit indicates the total number digits.	0 = Standard (without shrink tape)	Q = -10 +30% M = ±20%	E4 = Tray

PEH226	H	F	415	0	M	E4
Series	Rated Voltage (VDC)	Size Code	Capacitance Code (pF)	Version	Capacitance Tolerance	Packaging
Radial Crown Aluminum Electrolytic with Soldering Star Termination	H = 25 K = 40 M = 63 N = 80	See Dimension Table	The last two digits represent significant figures. The first digit indicates the total number digits.	0 = Standard (without shrink tape)	Q = -10 +30% M = ±20%	E4 = Tray

Performance Characteristics – PEH220

Item	Performance Characteristics		
Capacitance Range	250 – 4,700 μ F		
Rated Voltage	25 – 63 VDC		
Operating Temperature	-40 to +150°C		
Capacitance Tolerance	-10/+30%, (\pm 20% select values) at 100 Hz/+20°C		
Operational Lifetime	D (mm)	Rated voltage, +125°C (hours)	Rated voltage, +150°C (hours)
	16	6,300	1,500
	18 and 20	8,400	2,000
Shelf Life	5,000 hours at +105°C or 10 years at +40°C 0 VDC		
Leakage Current	$I = 0.003 CV + 4.0$ (μ A)		
	C = rated capacitance (μ F), V = rated voltage (VDC). Voltage applied for 5 minutes at +20°C.		
Vibration Test Specifications	Procedure		Requirements
	1.5 mm displacement amplitude or 20 G maximum acceleration. Vibration applied for three 22-hour sessions at 10 – 2,000 Hz (capacitor clamped by body).		No leakage of electrolyte or other visible damage. Deviations in capacitance from initial measurements must not exceed: $\Delta C/C < 5\%$
Standards	IEC 60384-4 long life grade 40/125/56, AEC-Q200		

Performance Characteristics – PEH225

Item	Performance Characteristics		
Capacitance Range	470 – 6,300 μ F		
Rated Voltage	25 – 63 VDC		
Operating Temperature	-40 to +125°C (-40 to +150°C at derated voltage)		
Capacitance Tolerance	-10/+30%, (\pm 20% select values) at 100 Hz/+20°C		
Operational Lifetime	D (mm)	Rated voltage, +125°C (hours)	Rated voltage, +150°C (hours)
	16	6,300	1,500
	18 and 20	8,400	2,000
Shelf Life	5,000 hours at +105°C or 10 years at +40°C 0 VDC		
Leakage Current	$I = 0.003 CV + 4.0$ (μ A)		
	C = rated capacitance (μ F), V = rated voltage (VDC). Voltage applied for 5 minutes at +20°C.		
Vibration Test Specifications	Procedure		Requirements
	1.5 mm displacement amplitude or 20 G maximum acceleration. Vibration applied for three 22-hour sessions at 10 – 2,000 Hz (capacitor clamped by body).		No leakage of electrolyte or other visible damage. Deviations in capacitance from initial measurements must not exceed: $\Delta C/C < 5\%$
Standards	IEC 60384-4 long life grade 40/125/56, AEC-Q200		

Performance Characteristics – PEH226

Item	Performance Characteristics		
Capacitance Range	250 – 4,700 μ F		
Rated Voltage	25 – 80 VDC		
Operating Temperature	-40 to +150°C		
Capacitance Tolerance	-10/+30%, (\pm 20% select values) at 100 Hz/+20°C		
Operational Lifetime	D (mm)	Rated voltage, +125°C (hours)	Rated voltage, +150°C (hours)
	16	6,300	1,500
	18 and 20	8,400	2,000
Shelf Life	5,000 hours at +105°C or 10 years at +40°C 0 VDC		
Leakage Current	$I = 0.003 CV + 4.0 (\mu A)$		
	C = rated capacitance (μ F), V = rated voltage (VDC). Voltage applied for 5 minutes at +20°C.		
Vibration Test Specifications	Procedure		Requirements
	1.5 mm displacement amplitude or 20 G maximum acceleration. Vibration applied for three 22-hour sessions at 10 – 2,000 Hz (capacitor clamped by body).		No leakage of electrolyte or other visible damage. Deviations in capacitance from initial measurements must not exceed: $\Delta C/C < 5\%$
Standards	IEC 60384-4 long life grade 40/125/56, AEC-Q200		

Compensation Factor of Ripple Current (RC) vs. Frequency

Frequency	100 Hz	300 Hz	1 kHz	5 kHz	100 kHz
Coefficient	0.35	0.57	0.80	1.00	1.04

Test Method & Performance

Endurance Life Test	
Conditions	Performance
Temperature	+150°C
Test Duration	1,500 hours (D = 16 mm)
	2,000 hours (D = 18 and 20 mm)
Ripple Current	Maximum ripple current specified in table
Voltage	The sum of DC voltage and the peak AC voltage must not exceed the rated voltage of the capacitor
Performance	The following specifications will be satisfied when the capacitor is tested at +20°C:
Capacitance Change	Within 15% of the initial value
Equivalent Series Resistance	Does not exceed 200% of the initial value
Leakage Current	Does not exceed leakage current limit

Ordering Options Table

Packaging Kind	Lead Length (mm)	Lead and Packaging Code
Standard Packaging Option		
Tray	3.3 ±0.5	E4

Dimensions – Top Welded Crown (Millimeters)

END VIEW (+)

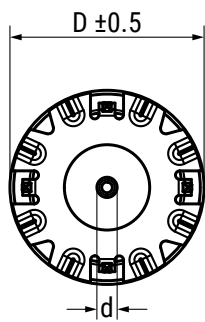

SIDE VIEW

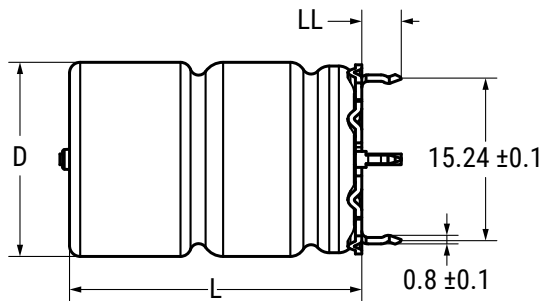

Size Code	Dimensions in mm				Comment	Approximate Weight Grams
	D	L	d	LL		
	±0.5	±1	±0.03	±0.5		
F	16.0	27.7	1.0	3.3	New Project Design*	8
G	16.0	35.7	1.0	3.3	New Project Design*	11
M	18.0	27.5	1.0	3.3		11
N	18.0	35.5	1.0	3.3		14
V	18.0	39.5	1.0	3.3		16
H	20.0	27.7	1.0	3.3	New Project Design*	13
J	20.0	35.7	1.0	3.3	New Project Design*	20
L	20.0	43.7	1.0	3.3	New Project Design*	24

New Project Design - Catalog parts in these sizes will come with the original Side Weld Crown shown below. New designs using these sizes will be issued a new part number and utilize the Top Weld Crown style.*

Dimensions – Side Welded Crown (Millimeters)

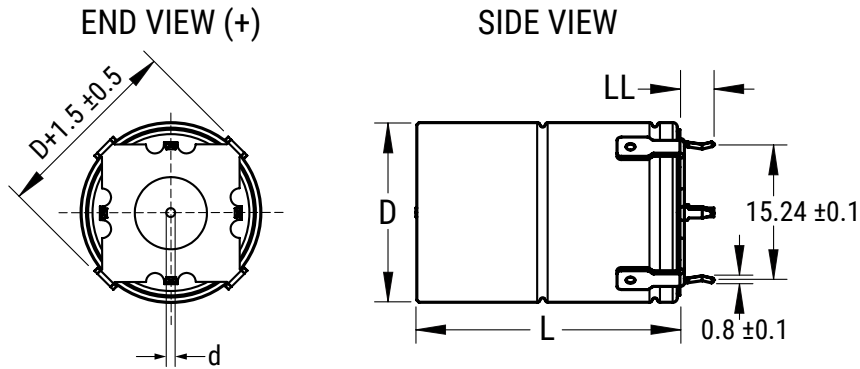

Size Code	Dimensions in mm				Approximate Weight Grams
	D	L	d	LL	
	±0.5	±1	±0.03	±0.5	
F	16.0	27.7	1.0	3.3	8
G	16.0	35.7	1.0	3.3	11
H	20.0	27.7	1.0	3.3	13
J	20.0	35.7	1.0	3.3	20
L	20.0	43.7	1.0	3.3	24

Shelf Life

The capacitance, ESR and impedance of a capacitor will not change significantly after extended storage periods, however, the leakage current will very slowly increase. KEMET products are particularly stable and allow a shelf life in excess of ten years at 40°C. See sectional specification under each product for specific data.

Failure Rate

Estimated field failure rate: ≤ 0.15 ppm (failures per year/produced number of capacitors per year).
The expected failure rate for this capacitor range is based on field experience for capacitors with structural similarity.
As per PEG Equivalents.

Environmental Compliance

As an environmentally conscious company, KEMET is working continuously with improvements concerning the environmental effects of both our capacitors and their production. In Europe (RoHS Directive) and in some other geographical areas like China, legislation has been put in place to prevent the use of some hazardous materials, such as lead (Pb), in electronic equipment. All products in this catalog are produced to help our customers' obligations to guarantee their products and fulfill these legislative requirements. The only material of concern in our products has been lead (Pb), which has been removed from all designs to fulfill the requirement of containing less than 0.1% of lead in any homogeneous material. KEMET will closely follow any changes in legislation world wide and make any necessary changes in its products, whenever needed.

Some customer segments such as medical, military and automotive electronics may still require the use of lead in electrode coatings. To clarify the situation and distinguish products from each other, a special symbol is used on the packaging labels for RoHS compatible capacitors.

Because of customer requirements, there may appear additional markings such as lead-free (LF) or lead-free wires (LFW) on the label.

Table 1A – PEH220, Ratings & Part Number Reference

VDC	Rated Capacitance	Size Code	Case Size	Ripple Current					ESR Maximum			Part Number
				Maximum			Rated	Maximum	100 Hz 20°C (mΩ)	100 kHz 20°C (mΩ)	5 – 100 kHz 125 – 150°C (mΩ)	
				≥ 5 kHz 125°C (A) ¹	≥ 5 kHz 140°C (A) ¹	≥ 5 kHz 150°C (A) ¹	≥ 5 kHz 125°C (A)	≥ 5 kHz 125°C (A)				
25	1500	F	16 x 27	13.9	8.8	3.9	4.8	6.1	78	42	18.4	PEH220HF4150ME4
25	2200	G	16 x 35	15.8	10.0	4.5	5.8	7.4	56	31	14.3	PEH220HG4220ME4
25	2000	M	18 x 27	15.1	9.5	4.3	5.2	6.6	61	34	17.2	PEH220HM4200QE4
25	3000	N	18 x 35	16.0	10.1	4.5	6.0	7.5	43	25	15.2	PEH220HN4300QE4
25	3400	V	18 x 39	17.9	11.3	5.1	6.7	8.6	38	22	12.2	PEH220HV4340QE4
25	2200	H	20 x 27	16.6	10.5	4.7	5.2	6.6	61	36	19.0	PEH220HH4220QE4
25	3300	J	20 x 35	19.1	12.1	5.4	6.4	8.1	43	26	14.3	PEH220HJ4330QE4
25	4700	L	20 x 43	21.0	13.3	5.9	7.4	9.3	32	20	11.8	PEH220HL4470QE4
40	800	F	16 x 27	13.6	8.6	3.9	4.7	5.9	108	43	19.2	PEH220KF3800QE4
40	1200	G	16 x 35	15.5	9.8	4.4	5.7	7.2	74	31	14.8	PEH220KG4120QE4
40	1200	M	18 x 27	14.9	9.4	4.2	5.1	6.5	77	34	17.7	PEH220KM4120QE4
40	1700	N	18 x 35	16.9	10.7	4.8	6.2	7.9	55	25	13.7	PEH220KN4170QE4
40	2000	V	18 x 39	17.6	11.1	5.0	6.7	8.5	48	22	12.6	PEH220KV4200QE4
40	1500	H	20 x 27	17.1	10.8	4.8	5.4	6.8	68	33	17.8	PEH220KH4150QE4
40	2200	J	20 x 35	19.4	12.2	5.5	6.5	8.2	49	25	13.9	PEH220KJ4220QE4
40	2700	L	20 x 43	20.7	13.1	5.9	7.3	9.2	39	20	12.1	PEH220KL4270QE4
63	250	F	16 x 27	10.5	6.6	3.0	3.6	4.5	233	59	32.4	PEH220MF3250QE4
63	370	G	16 x 35	12.2	7.7	3.5	4.5	5.7	160	42	23.9	PEH220MG3370QE4
63	380	M	18 x 27	12.1	7.6	3.4	4.2	5.3	158	44	26.8	PEH220MM3380QE4
63	560	N	18 x 35	14.0	8.8	4.0	5.2	6.6	110	32	20.0	PEH220MN3560QE4
63	640	V	18 x 39	14.7	9.3	4.2	5.6	7.1	96	28	18.1	PEH220MV3640QE4
63	470	H	20 x 27	14.2	9.0	4.0	4.5	5.7	134	41	25.9	PEH220MH3470QE4
63	680	J	20 x 35	16.3	10.3	4.6	5.6	7.0	94	30	19.7	PEH220MJ3680QE4
63	900	L	20 x 43	17.7	11.2	5.0	6.3	7.9	74	25	16.6	PEH220ML3900QE4
VDC	Rated Capacitance	Size Code	Case Size	Ripple Current					ESR			Part Number

¹ Capacitor mounted with low thermal resistance path (heat-sink.)

Table 1B – PEH225, Ratings & Part Number Reference

VDC	VDC	Rated Capacitance	Size Code	Case Size	Ripple Current					ESR Maximum			Part Number
					Maximum			Rated	Maximum (Reduced Voltage)	100 Hz 20°C (mΩ)	100 kHz 20°C (mΩ)	5 – 100 kHz 125 – 150°C (mΩ)	
	(150°C)	100 Hz 20°C (μF)	D x L (mm)	≥ 5 kHz 125°C (A) ¹	≥ 5 kHz 140°C (A) ²	≥ 5 kHz 150°C (A) ²	≥ 5 kHz 125°C (A)	≥ 5 kHz 125°C (A)					
25	18	2200	F	16 x 27	17.3	11.0	4.9	6.1	7.7	60	34	11.9	PEH225HF4220ME4
25	18	3000	G	16 x 35	19.7	12.5	5.6	7.4	9.4	44	25	9.2	PEH225HG4300ME4
25	18	2700	M	18 x 27	19.0	12.0	5.4	6.6	8.3	46	26	10.8	PEH225HM4270QE4
25	18	4000	N	18 x 35	21.3	13.5	6.0	7.9	10.0	33	19	8.6	PEH225HN4400QE4
25	18	4600	V	18 x 39	22.1	14.0	6.3	8.4	10.6	29	17	8.0	PEH225HV4460QE4
25	18	3600	H	20 x 27	23.5	14.9	6.7	7.6	9.6	38	22	9.4	PEH225HH4360QE4
25	18	4800	J	20 x 35	26.7	16.9	7.6	9.2	11.7	28	16	7.3	PEH225HJ4480QE4
25	18	6300	L	20 x 43	28.3	17.9	8.0	10.2	12.9	24	14	6.5	PEH225HL4630QE4
40	32	1200	F	16 x 27	16.6	10.5	4.7	5.8	7.4	80	36	13.0	PEH225KF4120ME4
40	32	1800	G	16 x 35	19.3	12.2	5.5	7.2	9.2	55	25	9.6	PEH225KG4180ME4
40	32	1600	M	18 x 27	18.7	11.8	5.3	6.5	8.2	59	26	11.2	PEH225KM4160QE4
40	32	2200	N	18 x 35	20.7	13.1	5.9	7.7	9.7	44	20	9.1	PEH225KN4220QE4
40	32	2600	V	18 x 39	21.7	13.7	6.1	8.2	10.4	37	17	8.3	PEH225KV4260QE4
40	32	2000	H	20 x 27	22.8	14.4	6.5	7.3	9.3	50	23	10.0	PEH225KH4200QE4
40	32	3000	J	20 x 35	25.8	16.3	7.3	8.9	11.3	35	17	7.8	PEH225KJ4300QE4
40	32	3900	L	20 x 43	27.7	17.5	7.8	10.0	12.7	28	14	6.8	PEH225KL4390QE4
63	54	470	F	16 x 27	12.1	7.7	3.4	4.2	5.3	156	52	24.3	PEH225MF3470QE4
63	54	680	G	16 x 35	13.8	8.7	3.9	5.3	6.7	109	37	18.7	PEH225MG3680QE4
63	54	720	M	18 x 27	14.6	9.2	4.1	5.0	6.4	110	36	18.4	PEH225MM3720QE4
63	54	1000	N	18 x 35	16.6	10.5	4.7	6.2	7.8	75	26	14.1	PEH225MN4100QE4
63	54	1200	V	18 x 39	17.6	11.1	5.0	6.7	8.5	64	23	12.6	PEH225MV4120QE4
63	54	900	H	20 x 27	18.0	11.4	5.1	5.8	7.3	86	31	16.1	PEH225MH3900QE4
63	54	1400	J	20 x 35	20.9	13.2	5.9	7.3	9.2	57	22	11.9	PEH225MJ4140QE4
63	54	1800	L	20 x 43	22.8	14.4	6.5	8.3	10.5	45	18	10.0	PEH225ML4180QE4
VDC	VDC (150°C)	Rated Capacitance	Size Code	Case Size	Ripple Current					ESR			Part Number

¹ Capacitor-mounted with low thermal resistance path (heat-sink).

² Valid for capacitor supplied with reduced DC voltage, capacitor-mounted with low thermal resistance path.

Table 1C – PEH226, Ratings & Part Number Reference

VDC	Rated Capacitance	Size Code	Case Size	Ripple Current					ESR Maximum			Part Number
				Maximum			Rated	Maximum	100 Hz 20°C (mΩ)	100 kHz 20°C (mΩ)	5 – 100 kHz 1 25 – 150°C (mΩ)	
				≥ 5 kHz 125°C (A) ¹	≥ 5 kHz 140°C (A) ¹	≥ 5 kHz 150°C (A) ¹	≥ 5 kHz 125°C (A) ²	≥ 5 kHz 125°C (A)				
25	1500	F	16 x 27	16.8	10.6	4.7	5.9	7.4	72	36	12.7	PEH226HF4150ME4
25	2200	G	16 x 35	19.2	12.1	5.4	7.2	9.1	51	26	9.7	PEH226HG4220ME4
25	2000	M	18 x 27	18.8	11.9	5.3	6.5	8.3	53	26	11.0	PEH226HM4200QE4
25	3000	N	18 x 35	21.2	13.4	6.0	7.9	10.0	37	19	8.7	PEH226HN4300QE4
25	3400	V	18 x 39	22.0	13.9	6.2	8.3	10.5	33	17	8.1	PEH226HV4340QE4
25	2200	H	20 x 27	22.2	14.0	6.3	7.1	9.1	50	25	10.6	PEH226HH4220QE4
25	3300	J	20 x 35	25.8	16.3	7.3	8.9	11.3	34	17	7.8	PEH226HJ4330QE4
25	4700	L	20 x 43	28.5	18.0	8.1	10.3	13.1	25	13	6.4	PEH226HL4470QE4
40	800	F	16 x 27	16.2	10.2	4.6	5.6	7.2	100	36	13.6	PEH226KF3800QE4
40	1200	G	16 x 35	18.6	11.8	5.3	7.0	8.8	69	26	10.3	PEH226KG4120QE4
40	1200	M	18 x 27	18.3	11.6	5.2	6.3	8.0	70	27	11.7	PEH226KM4120QE4
40	1800	N	18 x 35	20.5	13.0	5.8	7.6	9.6	49	20	9.3	PEH226KN4180QE4
40	2000	V	18 x 39	21.4	13.6	6.1	8.1	10.3	43	17	8.5	PEH226KV4200QE4
40	1500	H	20 x 27	22.8	14.4	6.5	7.3	9.3	57	22	10.0	PEH226KH4150QE4
40	2200	J	20 x 35	25.7	16.2	7.3	8.9	11.2	41	17	7.9	PEH226KJ4220QE4
40	2700	L	20 x 43	27.9	17.6	7.9	10.1	12.8	32	13	6.7	PEH226KL4270QE4
63	250	F	16 x 27	11.5	7.3	3.3	4.0	5.1	227	53	26.9	PEH226MF3250QE4
63	370	G	16 x 35	13.6	8.6	3.9	5.1	6.4	155	37	19.2	PEH226MG3370QE4
63	380	M	18 x 27	14.0	8.9	4.0	4.9	6.1	151	36	19.9	PEH226MM3380QE4
63	560	N	18 x 35	16.2	10.2	4.6	6.0	7.6	104	26	14.9	PEH226MN3560QE4
63	640	V	18 x 39	17.1	10.8	4.8	6.5	8.2	91	23	13.3	PEH226MV3640QE4
63	470	H	20 x 27	17.3	10.9	4.9	5.5	7.0	125	32	17.5	PEH226MH3470QE4
63	680	J	20 x 35	20.0	12.7	5.7	6.9	8.7	87	23	13.0	PEH226MJ3680QE4
63	900	L	20 x 43	22.2	14.0	6.3	8.1	10.2	67	18	10.6	PEH226ML3900QE4
80	250	F	16 x 27	9.9	6.3	2.8	3.4	4.4	279	105	36.3	PEH226NF3250QE4
80	370	G	16 x 35	12.0	7.6	3.4	4.4	5.7	190	72	25.0	PEH226NG3370QE4
80	380	M	18 x 27	12.2	7.7	3.4	4.3	5.5	187	72	26.3	PEH226NM3380QE4
80	560	N	18 x 35	14.3	9.0	4.0	5.4	6.9	128	50	19.2	PEH226NN3560QE4
80	640	V	18 x 39	15.0	9.5	4.2	5.9	7.5	113	45	17.4	PEH226NV3640QE4
80	470	H	20 x 27	15.4	9.8	4.4	4.9	6.4	152	60	21.9	PEH226NH3470QE4
80	680	J	20 x 35	18.1	11.4	5.1	6.3	8.0	106	42	15.9	PEH226NJ3680QE4
80	900	L	20 x 43	20.3	12.8	5.7	7.4	9.4	81	32	12.7	PEH226NL3900QE4
VDC	Rated Capacitance	Size Code	Case Size	Ripple Current					ESR			Part Number

¹ Capacitor mounted with low thermal resistance path (heat-sink)

² Continuous operation at natural convection

Packaging Quantities

Size Code	Packaging Quantities
	Tray
F	528
G	352
M	480
N	320
V	320
H	432
J	288
L	288

Marking

PEH 220, +150°C, PEH 225, +125°C and +150°C, and PEH226, +150°C

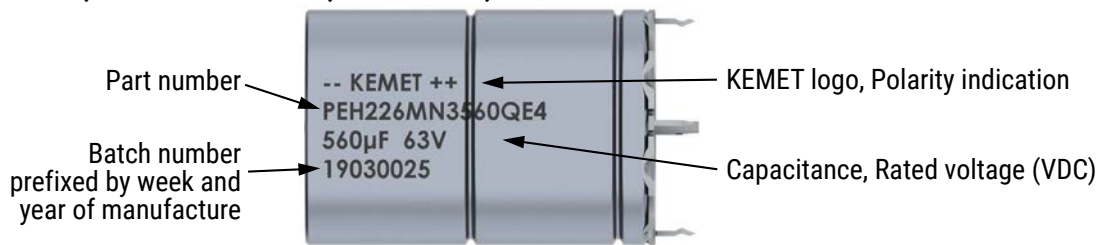

Construction

PEH 220, +150°C, PEH 225, +125°C and +150°C, and PEH226, +150°C

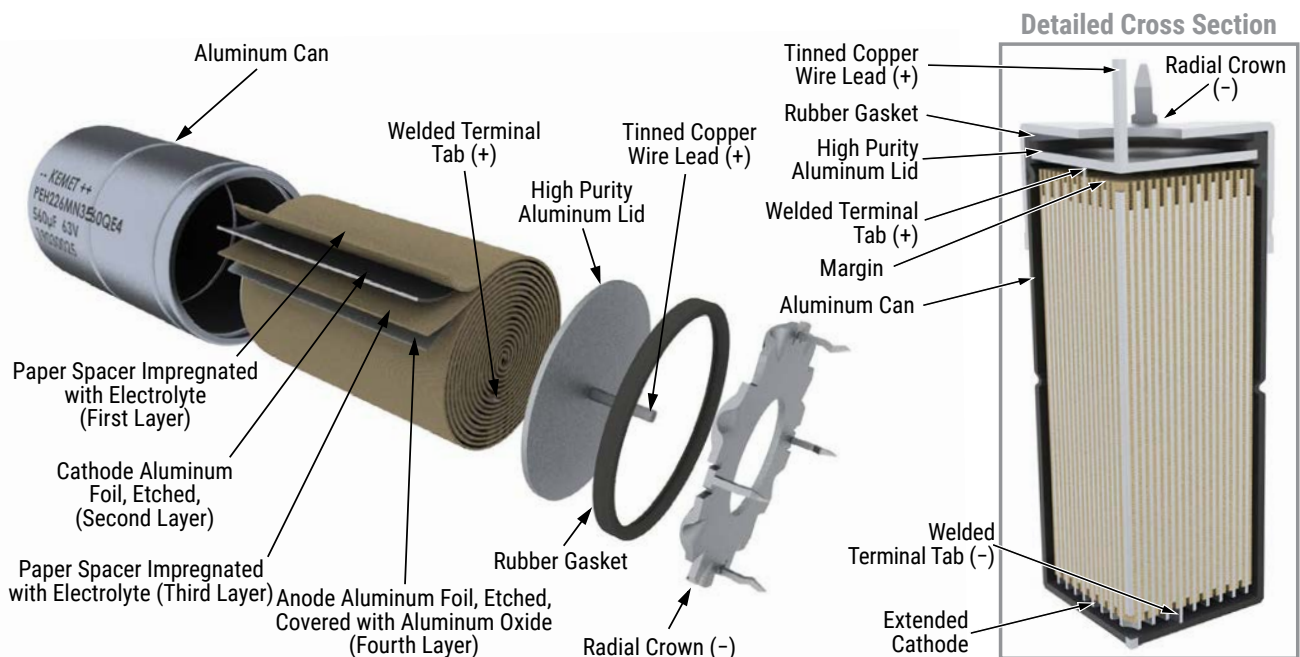

Construction Data – PEH 220, +150°C, PEH 225, +125°C and +150°C, and PEH226, +150°C

The manufacturing process begins with the anode foil being electrochemically etched to increase the surface area and then “formed” to produce the aluminum oxide layer. Both the anode and cathode foils are then interleaved with absorbent paper and wound into a cylinder. During the winding process, aluminum tabs are attached to each foil to provide the electrical contact.

The winding is assembled to the capacitor Al-can and to the Al-lid. The can is filled with electrolyte and the winding is impregnated during a vacuum treatment. The capacitor is sealed. Throughout the process, all materials inside the housing must be maintained at the highest purity and be compatible with the electrolyte.

Each capacitor is aged and tested before being packed. The purpose of aging is to repair any damage in the oxide layer and thus reduce the leakage current to a very low level. Aging is carried out at elevated temperature and is accomplished by applying voltage to the device while carefully controlling the supply current. The process takes between 2 and 20 hours, depending on voltage rating.

Damage to the oxide layer can occur due to a variety of reasons:

- Slitting of the anode foil after forming
- Attaching the tabs to the anode foil
- Minor mechanical damage caused during winding

The following tests are applied for each individual capacitor.

Electrical:

- Leakage current
- Capacitance
- ESR
- Tan Delta

Mechanical/Visual:

- Pull strength test of wire terminals
- Print detail
- Box labels
- Packaging, including packed quantity

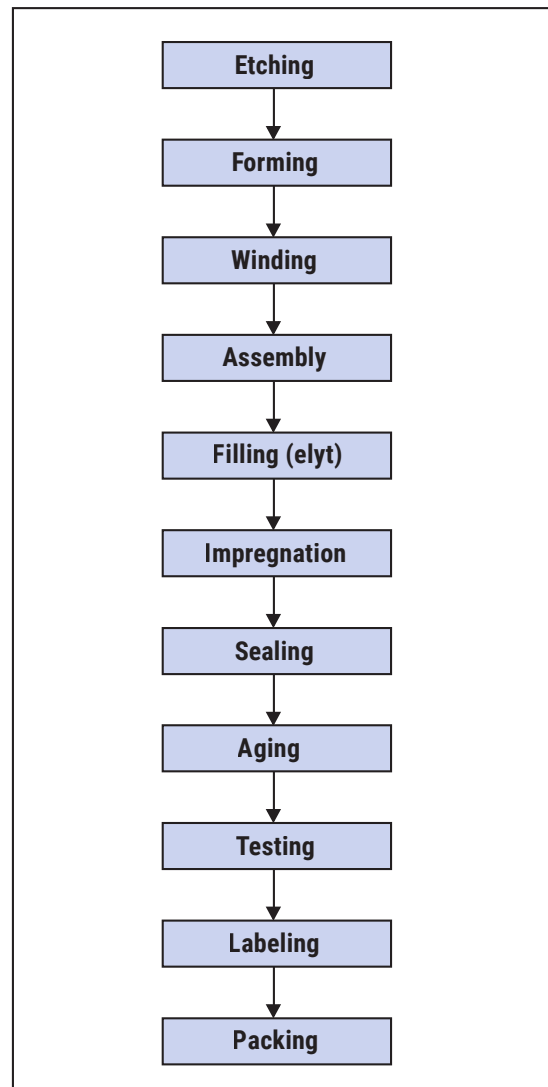
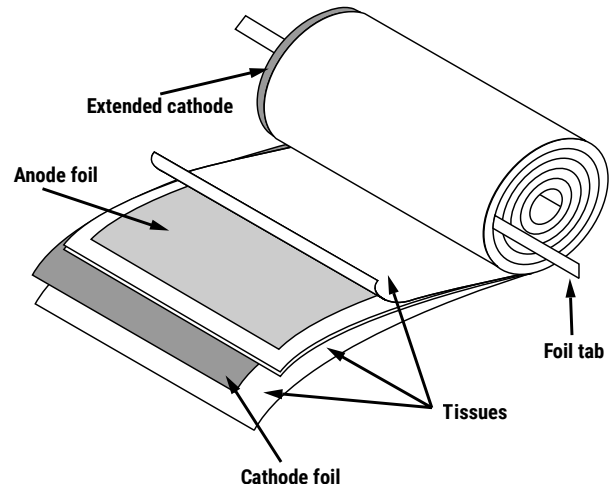

KEMET Electronics Corporation Sales Offices

For a complete list of our global sales offices, please visit www.kemet.com/sales.

Disclaimer

All product specifications, statements, information and data (collectively, the "Information") in this datasheet are subject to change. The customer is responsible for checking and verifying the extent to which the Information contained in this publication is applicable to an order at the time the order is placed. All Information given herein is believed to be accurate and reliable, but it is presented without guarantee, warranty, or responsibility of any kind, expressed or implied.

Statements of suitability for certain applications are based on KEMET Electronics Corporation's ("KEMET") knowledge of typical operating conditions for such applications, but are not intended to constitute – and KEMET specifically disclaims – any warranty concerning suitability for a specific customer application or use. The Information is intended for use only by customers who have the requisite experience and capability to determine the correct products for their application. Any technical advice inferred from this Information or otherwise provided by KEMET with reference to the use of KEMET's products is given gratis, and KEMET assumes no obligation or liability for the advice given or results obtained.

Although KEMET designs and manufactures its products to the most stringent quality and safety standards, given the current state of the art, isolated component failures may still occur. Accordingly, customer applications which require a high degree of reliability or safety should employ suitable designs or other safeguards (such as installation of protective circuitry or redundancies) in order to ensure that the failure of an electrical component does not result in a risk of personal injury or property damage.

Although all product-related warnings, cautions and notes must be observed, the customer should not assume that all safety measures are indicated or that other measures may not be required.

KEMET is a registered trademark of KEMET Electronics Corporation.

单击下面可查看定价，库存，交付和生命周期等信息

[>>KEMET\(基美\)](#)

[>>点击查看相关商品](#)