

## R76PN3220GYH3J

Aliases (76PN3220GYH3J)

R76H, Film, Double Metallized Polypropylene, Automotive Grade, 0.22 uF, 5%, 630 VDC, 105°C, Lead Spacing = 22.5mm

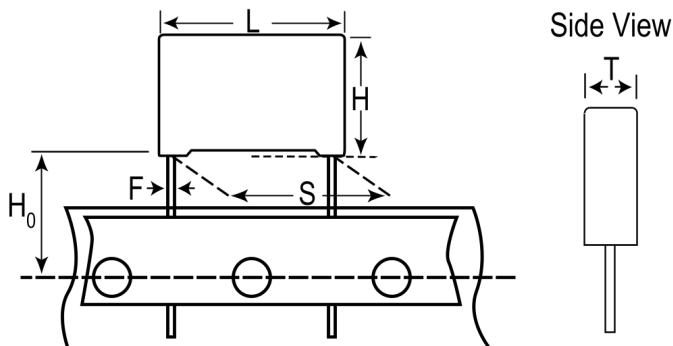

Click [here](#) for the 3D model.

### Dimensions

|    |                    |
|----|--------------------|
| L  | 26.5mm +0.3/-0.5mm |
| H  | 18.5mm +0.1/-0.5mm |
| T  | 10mm +0.2/-0.5mm   |
| S  | 22.5mm +/-0.4mm    |
| H0 | 18.5mm +/-0.5mm    |
| F  | 0.8mm +/-0.05mm    |

### Packaging Specifications

|                    |     |
|--------------------|-----|
| Packaging          | T&R |
| Packaging Quantity | 160 |

### General Information

|                 |                                 |
|-----------------|---------------------------------|
| Series          | R76H                            |
| Dielectric      | Double Metallized Polypropylene |
| Style           | Radial                          |
| Features        | Automotive Grade, Pulse         |
| RoHS            | Yes                             |
| Lead            | Wire Leads                      |
| Qualifications  | AEC-Q200                        |
| AEC-Q200        | Yes                             |
| THB Performance | Yes                             |

### Specifications

|                       |  |
|-----------------------|--|
| Capacitance           | 0.22 uF                                  |
| Capacitance Tolerance | 5%                                       |
| Voltage AC            | 400 VAC                                  |
| Voltage DC            | 630 VDC                                  |
| Temperature Range     | -55/+125°C                               |
| Rated Temperature     | 105°C                                    |
| Dissipation Factor    | 0.03% 1kHz, 0.06% 10kHz                  |
| Insulation Resistance | 100 GOhms                                |
| Max dV/dt             | 1500 V/us                                |
| Resistance            | 10.85 mOhms (100kHz)                     |
| Ripple Current        | 6.29 Amps (100kHz 100C), 330 Amps (Peak) |
| Inductance            | 16 nH                                    |

Statements of suitability for certain applications are based on our knowledge of typical operating conditions for such applications, but are not intended to constitute - and we specifically disclaim - any warranty concerning suitability for a specific customer application or use. This information is intended for use only by customers who have the requisite experience and capability to determine the correct products for their application. Any technical advice inferred from this information or otherwise provided by us with reference to the use of our products is given gratis, and we assume no obligation or liability for the advice given or results obtained.

单击下面可查看定价，库存，交付和生命周期等信息

[>>KEMET\(基美\)](#)