

## KL2601, KL2611

## DIP8 HIGH SPEED 10MBit/s

## LOGIC GATE PHOTOCOUPLER

DIP8 高速10MBit/s逻辑门光耦

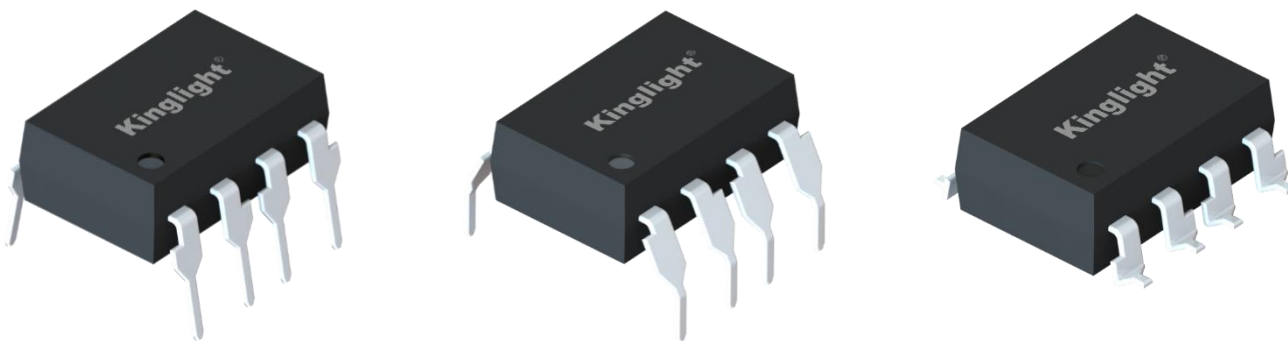

\* 本文档中包含的信息反映了具有代表性的使用场景，仅供技术参考。

The information contained in this document reflects representative usage scenarios and is intended for technical reference only.

\* 本文档中提到的产品型号和规格如有更改或改进，恕不另行通知。在生产使用之前，客户应参考产品规格书的最新数据表。

Product models and specifications mentioned in this document are subject to change or improvement without notice. Customers should refer to the latest data sheets in the product specifications prior to production use.

\* 在使用本文档中引用的产品时，请确保产品在数据手册中规定的环境和电气限制范围内运行。如果客户使用超过指定的限制，晶台将不会对任何后续问题负责。

When using the products referenced in this document, ensure that the products are operated within the environmental and electrical limits specified in the data sheet. If the customer uses the product beyond the specified limits, Kinglight will not be responsible for any subsequent problems.

\* 本文档中的信息适用于电子元器件应用中的典型用法。如有任何特殊用途，请向晶台咨询，以获得进一步的帮助。

The information in this document applies to typical use in electronic component applications. For special applications, please contact Kinglight for further assistance.

\* 未经晶台允许，不得复制或转载本文件的内容和信息。对于最新的信息，请参考官方网站 [Http://www.kinglight-semi.com](http://www.kinglight-semi.com)。

The contents and information in this document may not be copied or reproduced without the permission of Kinglight. For the latest information, please visit the official website [Http://www.kinglight-semi.com](http://www.kinglight-semi.com).

## 1. 产品特点 Product features

- 高速10MBit/s High speed 10Mbit/s
- 最小10kV/μs 共模瞬变抗扰度 (KL2611)  
10kV/μs min. common mode transient immunity (KL2611)
- 可保证在-40 至 85°C 温度范围内运行 Guaranteed performance from -40 to 85°C
- 逻辑门输出 Logic gate output
- 输入与输出间高隔离电压(Viso=5000 V rms)  
High isolation voltage between inputs and output (Viso=5000 V rms)
- 无卤素 (溴<900ppm, 氯<900ppm, 溴+氯<1500ppm)  
Halogens free (Br < 900ppm, Cl < 900ppm, Br+Cl < 1500ppm)
- 符合欧盟REACH法规 Compliance with EU REACH
- 无Pb且符合ROHS标准 Pb free and RoHS compliant
- 安全审批 Safety approval  
CQC认证已批准(编号:CQC23001408000) CQC approved (No: CQC23001408000)  
UL认证已批准(编号: UL-CA-2340753-0) UL approved (No: UL-CA-2340753-0)

## 2. 产品描述 Product Description

- KL2601 和 KL2611 由一个红外发射二极管和一个高速集成光电探测器逻辑门组成，后者具有频闪输出  
The KL2601 and KL2611 consist of an infrared emitting diode optically coupled to a high speed integrated photo detector logic gate with a strobable output
- 它们采用 8 引脚 DIP 封装，有宽引线间距和 SMD 两种选择  
They are packaged in a 8-pin DIP package and available in wide-lead spacing and SMD options

## 3. 产品应用 Product Applications

- 消除接地回路 Ground loop elimination
- LSTTL 至 TTL、LSTTL 或 5V CMOS LSTTL to TTL, LSTTL or 5 Volt CMOS
- 线路接收器、数据传输 Line receiver, data transmission
- 数据多路复用 Data multiplexing
- 开关电源 Switching power supplies
- 脉冲变压器更换 Pulse transformer replacement
- 计算机外围接口 Computer peripheral interface
- 高速逻辑接地隔离 High speed logic ground isolation

真值表(正逻辑) Truth Table (Positive Logic)

输入 Input	启用 Enable	输出 Output
H	H	L
L	H	H
H	L	H
L	L	H
H	NC	L
L	NC	H

## 4. 功能图 Functional Diagram

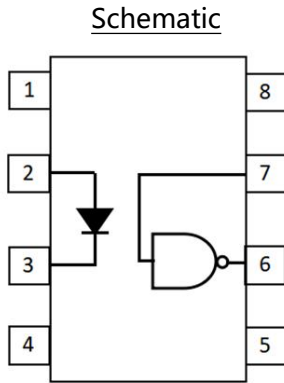

### 引脚配置 Pin Configuration

引脚5和引脚8之间必须连接0.1 $\mu$ F旁路电容器(3\*)  
A 0.1 $\mu$ F bypass capacitor must be connected  
between pins 8 and 5

### 引脚配置 Pin Configuration

- |                      |                   |
|----------------------|-------------------|
| 1. 无连线 No Connection | 5. 接地 GND         |
| 2. 阳极 Anode          | 6. 输出电压 $V_{out}$ |
| 3. 阴极 Cathode        | 7. 使能电压 $V_E$     |
| 4. 无连线 No Connection | 8. 工作电压 $V_{CC}$  |

## 5. 光电特性 Electrical-Optical characteristics

• 最大限度额定值(温度=25°C) Absolute Maximum Ratings(Ta=25°C)

参数 Parameter		符号 Symbol	额定值 Rated Value	单位 Unit
输入 Input	正向电流 Forward current	$I_F$	50	mA
	使能输入电压不超过 $V_{CC}$ 500mV Enable input voltage Not exceed $V_{CC}$ by more than 500mV	$V_E$	5.5	V
	反向电压 Reverse voltage	$V_R$	5	V
	功耗 Power dissipation ( $T_A = 25^\circ\text{C}$ )	$P_D$	100	mW
输出 Output	功耗 Power dissipation ( $T_A = 25^\circ\text{C}$ )	$P_C$	85	mW
	输出电流 Output current	$I_O$	50	mA
	输出电压 Output voltage	$V_O$	7.0	V
	工作电压 Supply voltage	$V_{CC}$	7.0	V
输出功率 Output Power Dissipation		$P_O$	100	mW
隔离电压 ( 1* ) Isolation Voltage		$V_{iso}$	5000	Vrms
工作温度 Operating temperature		$T_{OPR}$	-40 to +85	°C
储存温度 Storage temperature		$T_{STG}$	-55 to +125	°C
焊接温度 ( 2* ) Soldering temperature		$T_{SOL}$	260	°C

附注 (Notes):

1\* 交流电源1分钟内, 相对湿度在40~60%RH环境下, 隔离电压测试时, 1、2、3&4脚短接在一起, 5、6、7&8脚短接在一起

AC for 1 minute, R.H.= 40 ~ 60% R.H. In this test, pins 1, 2, 3&4 are shorted together, and pins 5, 6, 7&8 are shorted together.

2\* 焊接时间为10秒 Soldering time is 10 seconds

## 6. 电气特性(Ta=-40至85°C,除非另有规定)

## Electrical Characteristics(Ta=-40 to 85°C unless specified otherwise)

	参数 Parameter	符号 Symbol	最小值 Min.	规格值 Typ.	最大值 Max.	单位 Unit	条件 Condition
输入 In put	正向电压 Forward voltage	$V_F$	-	1.4	1.8	V	$I_F=10\text{mA}$
	反向电压 Reverse voltage	$V_R$	5.0	-	-	V	$I_R=10\mu\text{A}$
	正向电压温度系数 Temperature coefficient of forward voltage	$\Delta V_F/\Delta T_A$	-	-1.8	-	mV/°C	$I_F=10\text{mA}$
	输入电容 Input capacitance	$C_{IN}$	-	60	-	pF	$V_F=0$ , $f=1\text{MHz}$
输出 Out put	高电平工作电流 High level supply current	$I_{CCH}$	-	7	10	mA	$I_F=0\text{mA}$ , $V_E=0.5\text{V}$ $V_{CC}=5.5\text{V}$
	低电平工作电流 Low level supply current	$I_{CCL}$	-	9	13	mA	$I_F=10\text{mA}$ , $V_{CC}=5.5\text{V}$
	高电平使能电流 High level enable current	$I_{EH}$	-	-0.6	-1.6	mA	$V_E=2.0\text{V}$ , $V_{CC}=5.5\text{V}$
	低电平使能电流 Low level enable current	$I_{EL}$	-	-0.8	-1.6	mA	$V_E=0.5\text{V}$ , $V_{CC}=5.5\text{V}$
	高电平使能电压 High level enable voltage	$V_{EH}$	2.0	-	-	V	$I_F=10\text{mA}$ , $V_{CC}=5.5\text{V}$
	低电平使能电压(4*) Low level enable voltage	$V_{EL}$	-	-	0.8	V	$I_F=10\text{mA}$ , $V_{CC}=5.5\text{V}$

- 传输特性 (Ta=-40至85°C,除非另有规定)

Transfer Characteristics (Ta=-40 to 85°C unless specified otherwise)

参数 Parameter	符号 Symbol	最小值 Min.	规格值 Typ.*	最大值 Max.	单位 Unit	条件 Condition
高电平输出电流 HIGH Level Output Current	I <sub>OH</sub>	-	2.1	100	μA	V <sub>CC</sub> =5.5V, V <sub>O</sub> =5.5V, I <sub>F</sub> =250μA, V <sub>E</sub> =2.0V
低电平输出电压 LOW Level Output Current	V <sub>OL</sub>	-	0.35	0.6	V	V <sub>CC</sub> = 5.5V, I <sub>F</sub> =5mA V <sub>E</sub> =2.0V, I <sub>CL</sub> =13mA
输入阈值电流 Input Threshold Current	I <sub>FT</sub>	-	2.5	5	mA	V <sub>CC</sub> = 5.5V, V <sub>O</sub> =0.6V V <sub>E</sub> =2.0V, I <sub>OL</sub> =13mA

开关特性(Ta=-40至85°C, V<sub>CC</sub>=5V, I<sub>F</sub>=7.5mA, 除非另有说明)

Switching Characteristics (Ta=-40 to 85°C, V<sub>CC</sub>=5V, I<sub>F</sub>=7.5mA unless specified otherwise)

参数 Parameter	符号 Symbol	最小值 Min.	规格值 Typ.*	最大值 Max.	单位 Unit	条件 Condition
输出高电平的传播延迟时间( 5* ) Propagation delay time to output High level (Fig.12)	T <sub>PHL</sub>	-	35	75	ns	C <sub>L</sub> =15pF, R <sub>L</sub> =350Ω, T <sub>A</sub> =25°C
输出低电平的传播延迟时间( 6* ) Propagation delay time to output Low level (Fig.12)	T <sub>PLH</sub>	-	40	75	ns	C <sub>L</sub> =15pF, R <sub>L</sub> =350Ω T <sub>A</sub> =25°C
脉冲宽度失真 Pulse width distortion	T <sub>PHL</sub> -T <sub>PLH</sub>	-	5	35	ns	C <sub>L</sub> =15pF, R <sub>L</sub> =350Ω
输出上升时间( 7* ) Output rise time (Fig.12)	tr	-	40	-	ns	C <sub>L</sub> =15pF, R <sub>L</sub> =350Ω
输出下降时间( 8* ) Output fall time <sup>*8</sup> (Fig.12)	tf	-	10	-	ns	C <sub>L</sub> =15pF, R <sub>L</sub> =350Ω

开关特性(-40至85°C,  $V_{CC}=5V$ ,  $I_F=7.5mA$ , 除非另有说明)

Switching Characteristics ( $T_a=-40$  to  $85^\circ C$ ,  $V_{CC}=5V$ ,  $I_F=7.5mA$  unless specified otherwise)

参数 Parameter	符号 Symbol	最小值 Min.	规格值 Typ.*	最大值 Max.	单位 Unit	条件 Condition
到输出高电平的使能传播延迟时间(9*) Enable Propagation Delay Time to Output High Level (Fig.13)	$t_{ELH}$	-	15	-	ns	$I_F=7.5mA$ , $V_{EH}=3.5V$ , $C_L=15pF$ , $R_L=350\Omega$
到输出低电平的使能传播延迟时(10*) Enable Propagation Delay Time to Output Low Level (Fig.13)	$t_{EHL}$	-	15	-	ns	$I_F=7.5mA$ , $V_{EH}=3.5V$ , $C_L=15pF$ , $R_L=350\Omega$
逻辑高电平下的共模瞬态抗扰度(11*) Common Mode Transient Immunity at Logic High	KL2601	5,000	-	-	V/ $\mu S$	$I_F=0mA$ , $V_{OH}=2.0V$ , $R_L=350\Omega$ , $T_A=25^\circ C$ $V_{CM}=50Vp-p$ (Fig.14)
	KL2611	10,000	-	-		$I_F=0mA$ , $V_{OH}=2.0V$ , $R_L=350\Omega$ , $T_A=25^\circ C$ $V_{CM}=400Vp-p$ (Fig.14)
	KL2611	20,000	-	-		$I_F=0mA$ , $V_{OH}=2.0V$ , $R_L=350\Omega$ , $T_A=25^\circ C$ $V_{CM}=400Vp-p$ (Fig.15)
逻辑低电平下的共模瞬态抗扰度(12*) Common Mode Transient Immunity at Logic Low	KL2601	5,000	-	-	V/ $\mu S$	$I_F=7.5mA$ , $V_{OL}=0.8V$ , $R_L=350\Omega$ , $T_A=25^\circ C$ $V_{CM}=50Vp-p$ (Fig.14)
	KL2611	10,000	-	-		$I_F=7.5mA$ , $V_{OL}=0.8V$ , $R_L=350\Omega$ , $T_A=25^\circ C$ $V_{CM}=400Vp-p$ (Fig.14)
	KL2611	20,000	-	-		$I_F=7.5mA$ , $V_{OH}=0.8V$ , $R_L=350\Omega$ , $T_A=25^\circ C$ $V_{CM}=400Vp-p$ (Fig.15)

## 7. 可靠性试验 Reliability Test

序号 NO.	试验项目 Test Items	参考标准 Reference	试验条件 Test conditions	试验过程 Test process	试验数 Qty.(pcs)	允收水准 LTPD
1	温度循环 TC	JESD22-A104C	H:125±5°C 15min J5min L:-55±5°C 15min	300cycle	45	0/45
2	高温操作寿命 HTOL	JESD22-A108C	HTOL@85±5°C I <sub>F</sub> =10mA I <sub>O</sub> =5mA V <sub>CC</sub> =5V	168、500、 1000hrs	45	0/45
3	温湿度寿命试验 HTHB	JESD22- A101- B	HTHB@85+5/-2°C、 85±5%RH I <sub>F</sub> =10mA, I <sub>O</sub> =5mA, V <sub>CC</sub> =5V	168、500、 1000hrs	45	0/45
4	压力锅 PCT	JESD22-A102- C	T <sub>a</sub> =121±5°C, 100±5%RH, 2atm	96hrs	45	0/45
5	高温储存 HTS	JESD22-A103C	HTS@125±5°C	168、500、 1000hrs	45	0/45
6	低温储存 LTS	JESD22-A119	LTS@-40±5°C	168、500、 1000hrs	45	0/45
7	耐锡热试验 RSH	JESD22-B106C	RSH@260±5°C	10sec*3times	45	0/45
8	反转实验 IT	/	IT@25±5°C V <sub>IO</sub> =1000V DC	168hrs	45	0/45
9	可焊性 SD	JESD22-B102D	Pb-free@ 245±5°C	3sec*1times	22	0/22
备注 Remarks	<p>以上试验项目如与客户试验要求存在差异或者特殊客户特殊要求的,可根据实际情况按照客户的要求进行试作,客户未要求依我司试验标准试作,不同产品使用不同电流进行测试</p> <p>All the tests should be performed according to customers' actual requirements, while difference of test standard or special requirements exist. Otherwise, all the tests are performed according to the standard listed above. Different current is applied to the tests of different product models</p>					



## 8. 特性曲线 Characteristic Curves

图1. 输入二极管正向电流 vs 正向电压的关系

Figure 1. Input Diode Forward Current vs

Forward Voltage



图2 低电平输出电压 vs 环境温度的关系

Fig.2 Low Level Output Voltage vs Ambient

Temperature

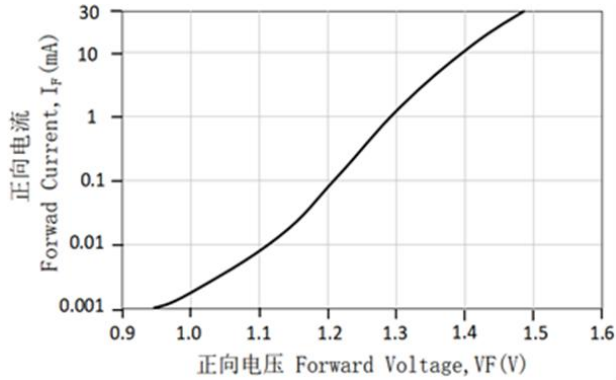

图3. 低电平输出电流 vs 环境温度的关系

Figure 3. Low Level Output Current vs

Ambient Temperature

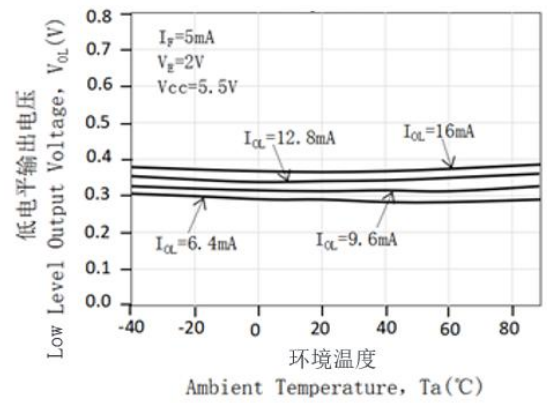

图4. 输入阈值电流 vs 环境温度的关系

Figure 4. Input Threshold Current vs

Ambient Temperature

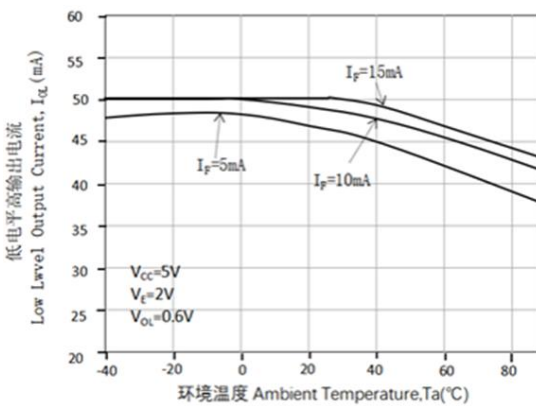

图5. 输出电压 vs 输入正向电流的关系

Figure 5. Output Voltage vs Forward Current

Temperature

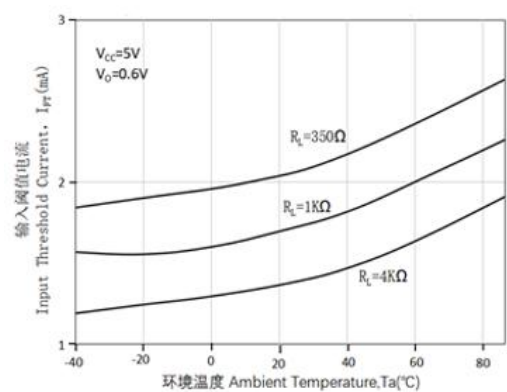

图6. 高电平输出电流 vs 温度的关系

Figure 6. High Level Output Current vs

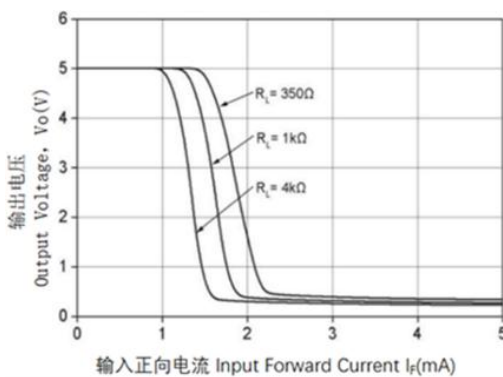

图7. 转换时间 vs 集电极电流的关系

Figure 7. Switching Time vs Forward Current

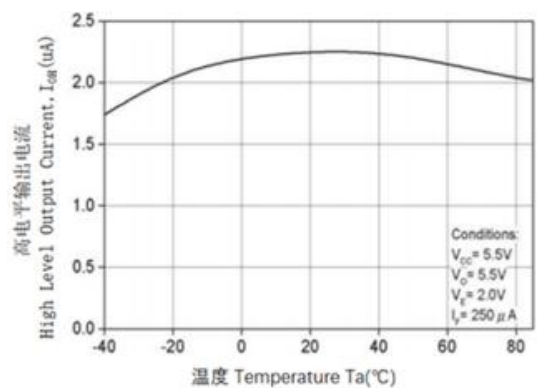

图8. 转换时间 vs 温度的关系

Figure 8. Switching Time vs Temperature

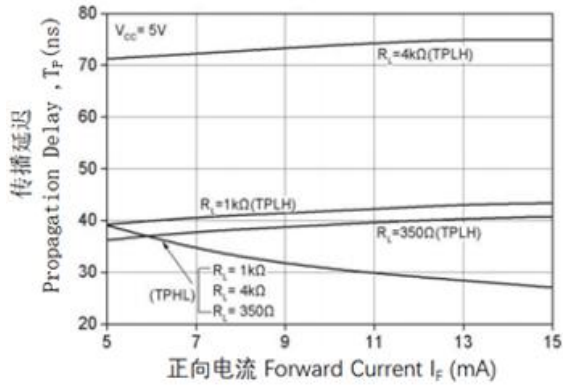

图9. 脉冲宽度失真 vs 温度的关系

Figure 9. Pulse Width Distortion vs Temperature

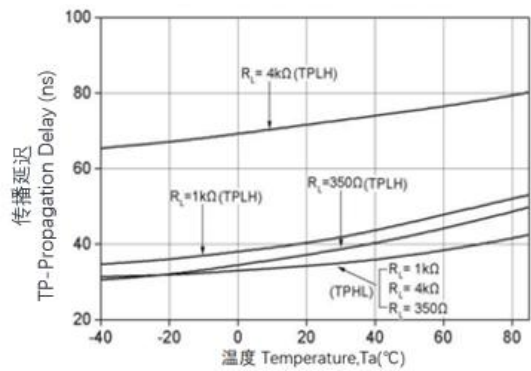

图10. 上升和下降时间 vs 温度的关系

Figure 10. Rise and Fall Time vs Temperature

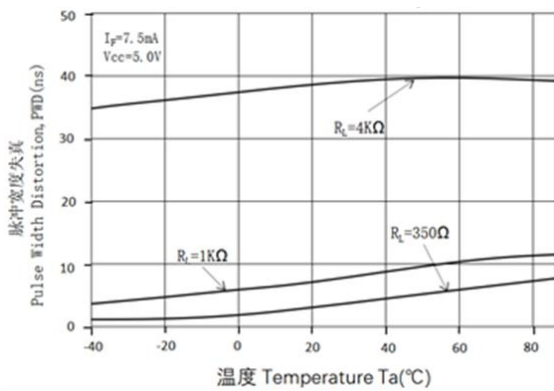

图11. 使能传播延迟 vs 温度的关系

Figure 11. Enable Propagation Delay vs Temperature



图12.  $t_{PHL}$ ,  $t_{PLH}$ ,  $t_r$  和  $t_f$ 的测试电路和波形 Test circuit and waveforms for  $t_{PHL}$ ,  $t_{PLH}$ ,  $t_r$  and  $t_f$

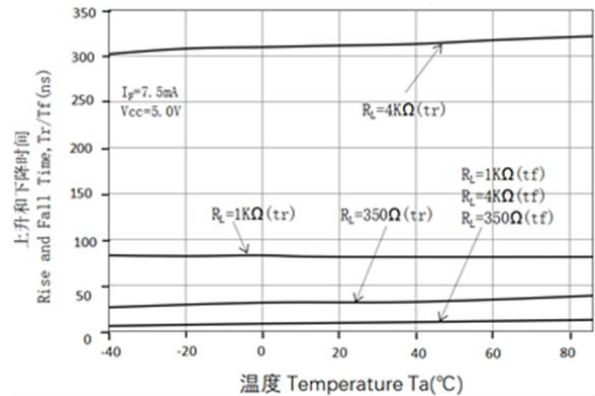

图13.测试电路与 $t_{EHL}$ 和 $t_{ELH}$ 的波形 Test circuit and waveform for  $t_{EHL}$  and  $t_{ELH}$

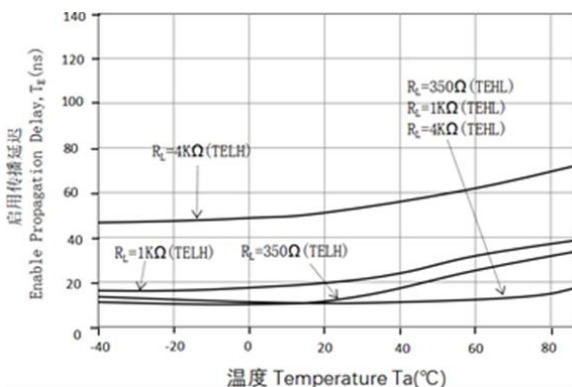

图14.测试电路共模瞬态抗扰度 Test circuit Common mode Transient Immunity

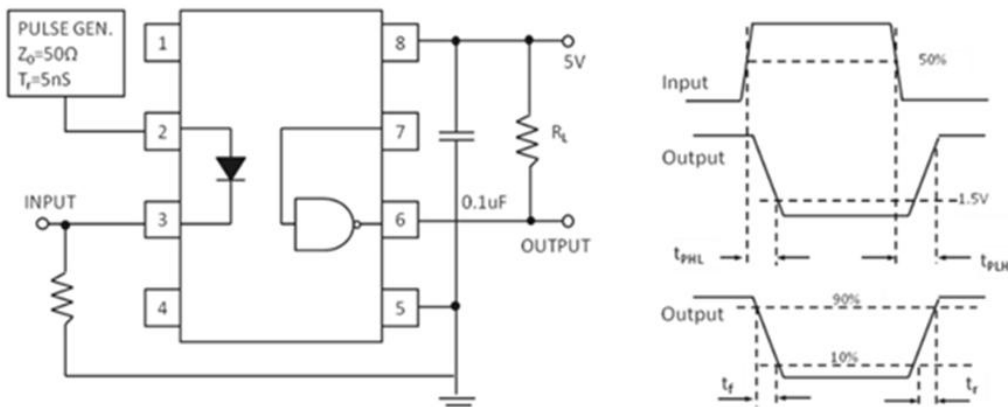

图15.KL2611系列高CMR推荐的驱动电路

Recommended drive circuit for KL2611 families for high-CMR

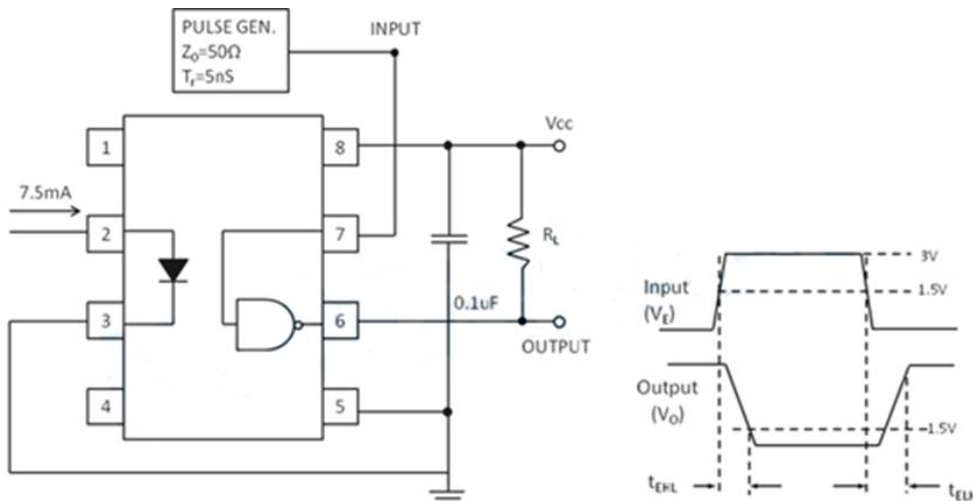

\*3  $V_{CC}$ 必须由一个 $0.1\mu\text{F}$ 或更大的电容器旁路。该电容可以是陶瓷电容，也可以是具有良好高频特性的固体钽电容，并应尽可能靠近封装的 $V_{CC}$ 和GND引脚连接

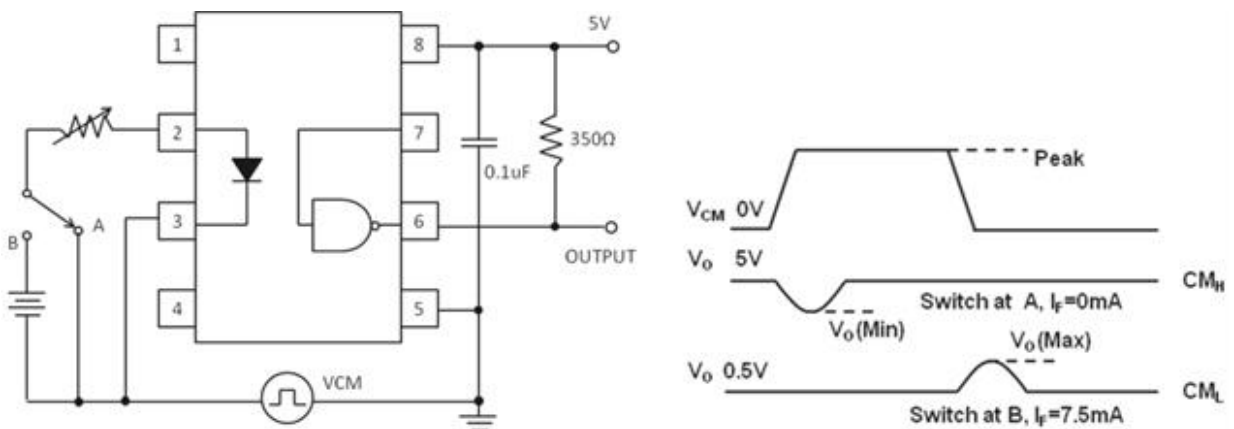
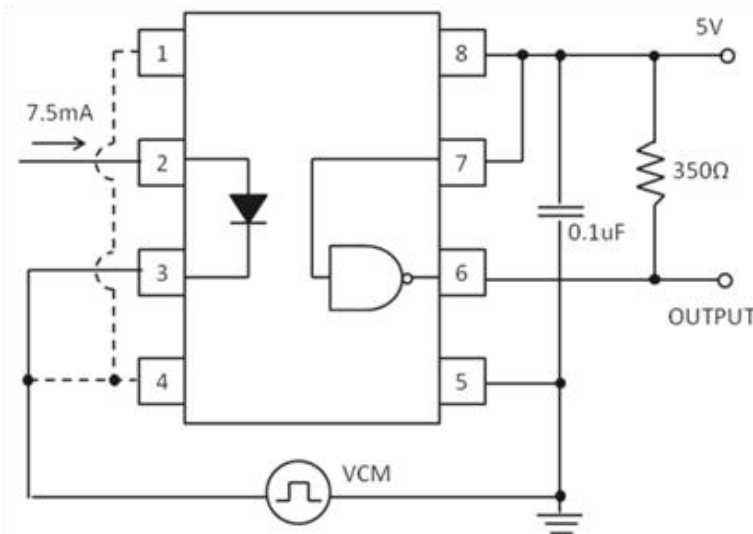
The  $V_{CC}$  supply must be bypassed by a  $0.1\mu\text{F}$  capacitor or larger. This can be either a ceramic or solid tantalum capacitor with good high frequency characteristic and should be connected as close as possible to the package  $V_{CC}$  and GND pins

\*4 使能输入-不需要上拉电阻器，因为设备内部有一个上拉电阻器

Enable Input – No pull up resistor required as the device has an internal pull up resistor

\*5  $t_{PLH}$ -传播延迟是从输入电流脉冲从高电平到低电平转换时的  $3.75\text{mA}$  电平到输出电压脉冲从低电平到高水平转换时的  $1.5\text{V}$  电平之间测量的

$t_{PLH}$ -Propagation delay is measured from the  $3.75\text{mA}$  level on the HIGH to LOW transition of the input current pulse to the  $1.5\text{V}$  level on the LOW to HIGH transition of the output voltage pulse

\*6.  $t_{PHL}$ -传播延迟是从输入电流脉冲低电平到高水平转换时的  $3.75\text{mA}$  电平到输出电压脉冲高水平到低电平转换时的  $1.5\text{V}$  电平之间测量的

$t_{PHL}$ -Propagation delay is measured from the  $3.75\text{mA}$  level on the LOW to HIGH transition of the input current pulse to the  $1.5\text{V}$  level on the HIGH to LOW transition of the output voltage pulse.

\*7.  $t_r$ -上升时间是指输出脉冲从低电平转换为高电平时，从  $90\%$  电平到  $10\%$  电平之间的上升时间

$t_r$ -Rise time is measured from the  $90\%$  to the  $10\%$  levels on the LOW to HIGH transition of the output pulse

\*8.  $t_f$ -下降时间是从输出脉冲从高水平到低电平转换时的  $10\%$  到  $90\%$  电平之间测量的

$t_f$ - Fall time is measured from the  $10\%$  to the  $90\%$  levels on the HIGH to LOW transition of the output pulse

\*9.  $t_{ELH}$ -使能输入传播延迟是从输入电压脉冲从高电平到低电平转换时的 1.5V 电平到输出电压脉冲从低电平到高电平转换时的 1.5V 电平之间测量的

$t_{ELH}$ -Enable input propagation delay is measured from the 1.5V level on the HIGH to LOW transition of the input voltage pulse to the 1.5V level on the LOW to HIGH transition of the output voltage pulse

\*10.  $t_{EHL}$ -使能输入传播延迟是从输入电压脉冲低电平到高电平转换时的 1.5V 电平，到输出电压脉冲高电平到低电平转换时的 1.5V 电平之间测量的

$t_{EHL}$ -Enable input propagation delay is measured from the 1.5V level on the LOW to HIGH transition of the input voltage pulse to the 1.5V level on the HIGH to LOW transition of the output voltage pulse

\*11. CMH-为确保输出保持在高电平状态 (即  $V_{OUT} > 2.0V$ )，共模电压的最大可容许上升率

CMH-The maximum tolerable rate of rise of the common mode voltage to ensure the output will remain in the HIGH state (i.e.,  $V_{OUT} > 2.0V$ )

\*12. CML-为确保输出保持在低电平输出状态 (即  $V_{OUT} < 0.8V$ )，共模电压的最大可容许上升率

CML-The maximum tolerable rate of rise of the common mode voltage to ensure the output will remain in the LOW output state (i.e.,  $V_{OUT} < 0.8V$ )

## 9. 订单信息 Order Information

- 材料编号 Part Number

# KL26XXY-Z-V

### 附注(Notes):

XX = KL26系列的零件编号(XX=01或11)

(01 or 11) for KL26 part no.

Y = 引脚形式选项(DIP、S、S1、M)

Lead form option (DIP, S, S1, M)

Z = 料带和卷轴选项(TA、TB)

Tape and reel option (TA, TB)

V = 表示VDE标识(客户指定镭射字符才加"V")

VDE (Only add "V" to laser characters specified by the customer)

选项 Option	描述 Description	包装数量 Packing quantity
无 None	标准DIP-8 Standard DIP-8	每管45pcs 45 units per tube
M	宽引脚弯曲(0.4英寸间距) Wide lead bend (0.4 inch spacing)	每管45pcs 45 units per tube
S-TA	表面贴装引线形式+TA载带和卷轴选项 Surface mount lead form + TA tape & reel option	每卷1000pcs 1000 units per reel
S-TB	表面贴装引线形式+TB载带和卷轴选项 Surface mount lead form + TB tape & reel option	每卷1000pcs 1000 units per reel
S1-TA	表面贴装引线形式(低剖面)+TA载带和卷轴选项 Surface mount lead form (low profile) + TA tape & reel option	每卷1000pcs 1000 units per reel
S1-TB	表面贴装引线形式(低剖面)+TB载带和卷轴选项 Surface mount lead form (low profile) + TB tape & reel option	每卷1000pcs 1000 units per reel

### 10. 封装尺寸(单位:毫米) Package Drawing(Unit:mm)

- 标准DIP型号 Standard DIP Type

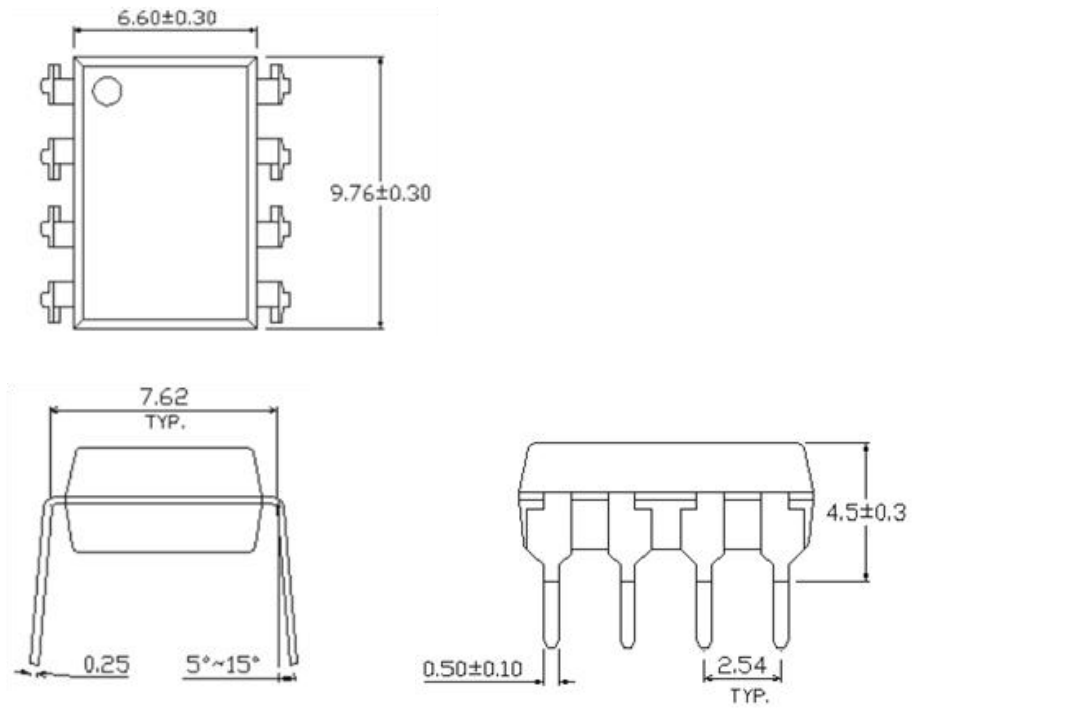

- 选择M型号 Option M Type

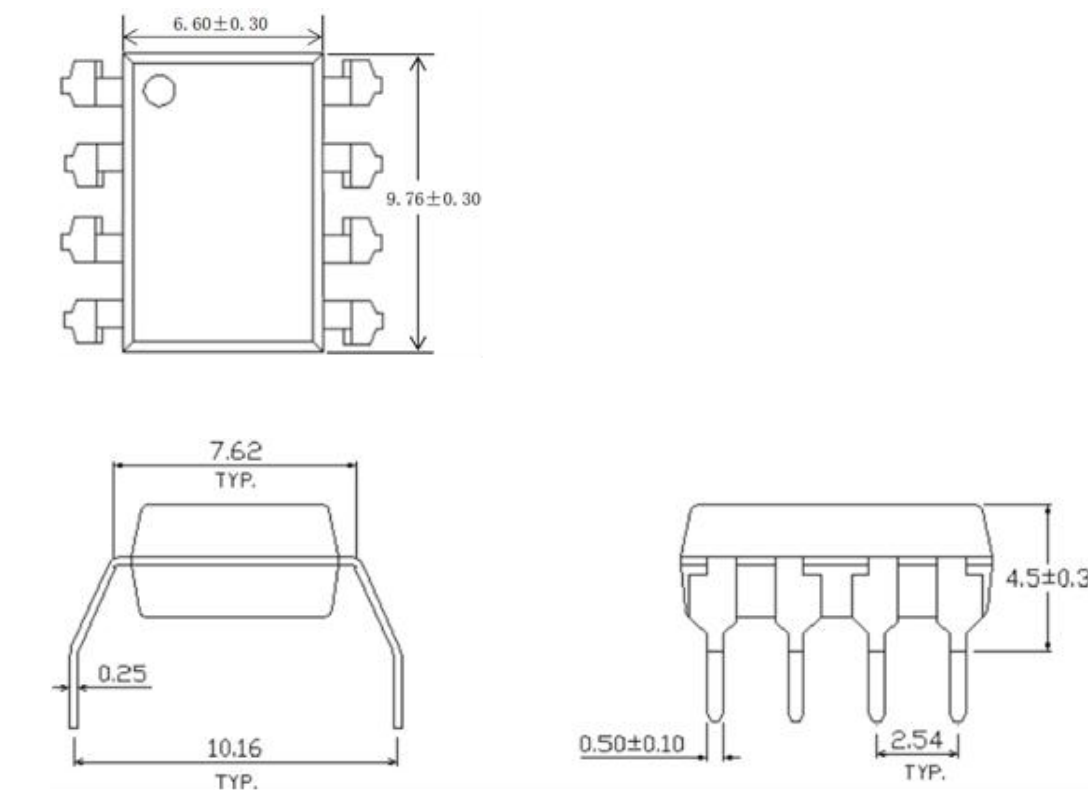

• 选择S型号 Option S Type

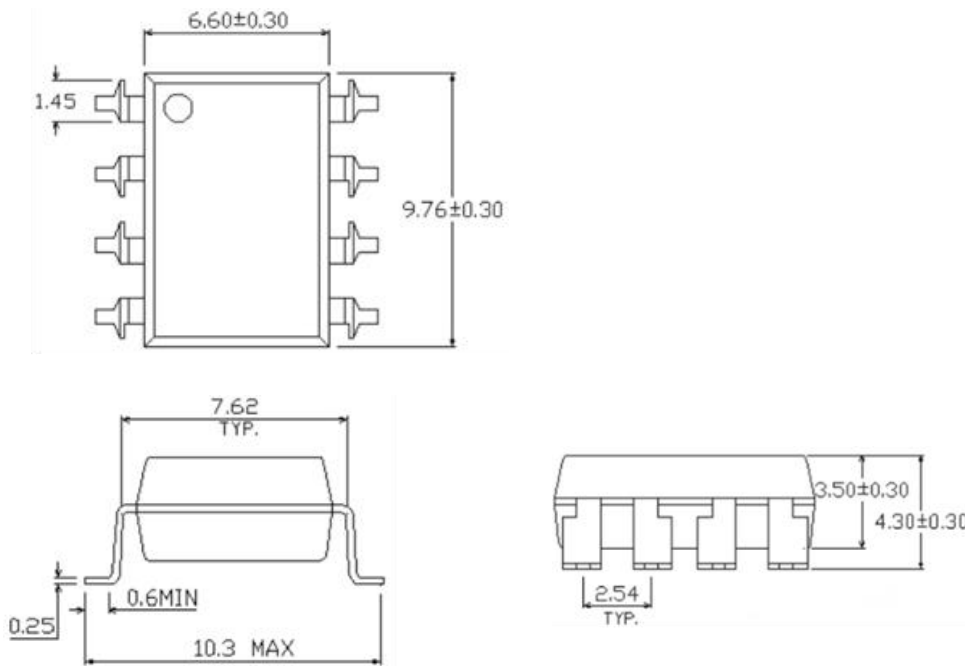

• 选择S1型号 Option S1 Type

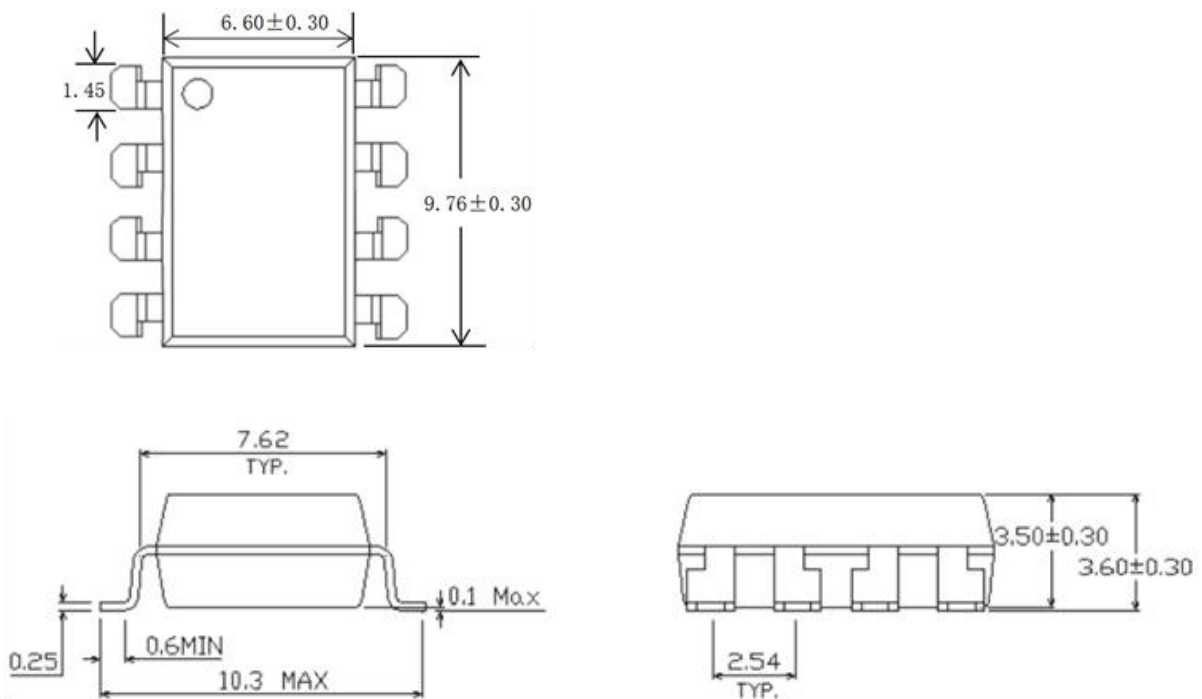



- 表面贴片类型PIN脚焊盘布局 Surface patch type PIN foot pad layout

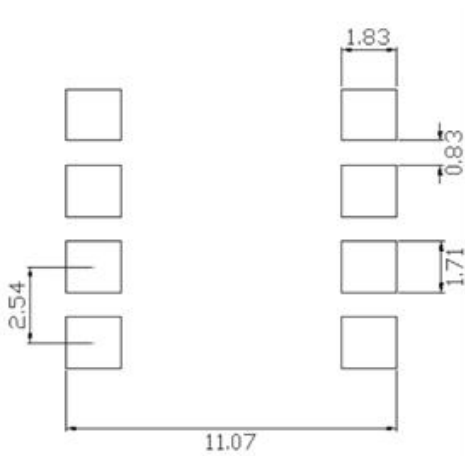

#### 备注 Notes

- 建议焊盘尺寸仅供参考 Suggested pad dimension is just for reference only
- 请根据个人需要修改焊盘尺寸 Please modify the pad dimension based on individual need

## 11. 设备标记 Device marking

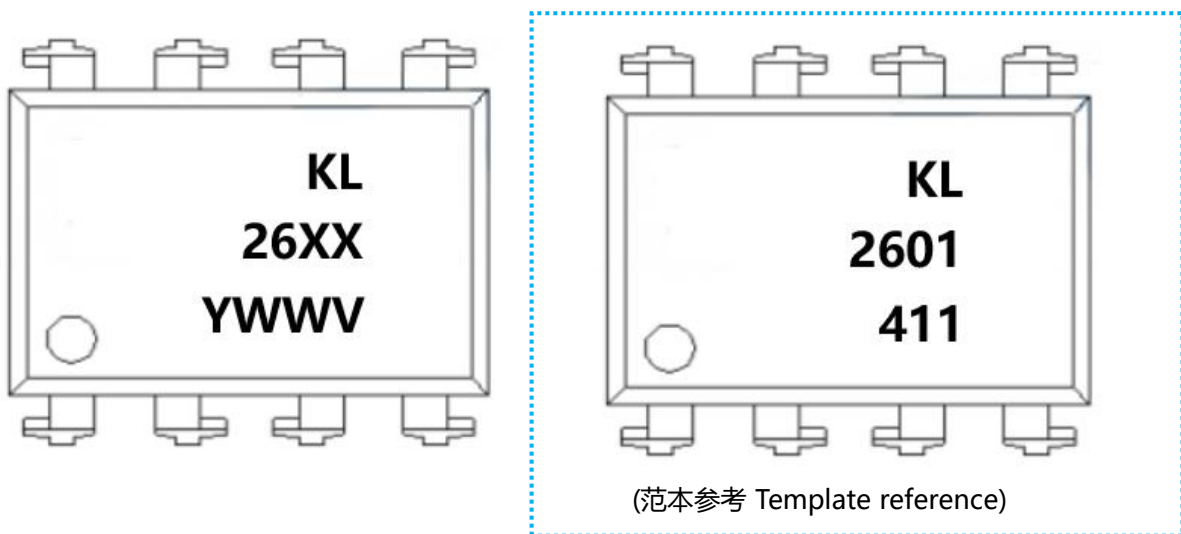

### 附注(Notes):

- KL = 表示晶台光电有限公司 Denotes KingLight
- 26XX = 表示材料部件号 Denotes Device Part Number  
XX表示零件编号(01、11) Part No. (01, 11)
- Y = 表示1位年份代码Denotes 1 digit Year code
- WW = 表示2位周别代码Denotes 2 digit Week code
- V = 表示VDE标识(客户指定镭射字符才加"V")  
VDE (Only add "V" to laser characters specified by the customer)

## 12. 料带和卷轴包装规格 Tape & Reel Packing Specifications

• 选择TA Option TA

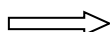
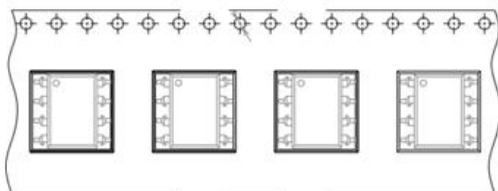

卷轴进给方向 Direction of feed from reel

• 选择TB Option TB

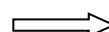
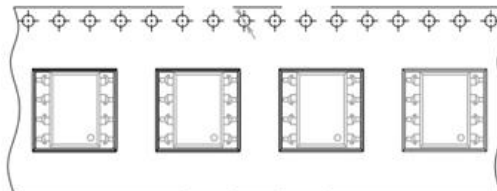

卷轴进给方向 Direction of feed from reel

### 料带尺寸 Material belt size

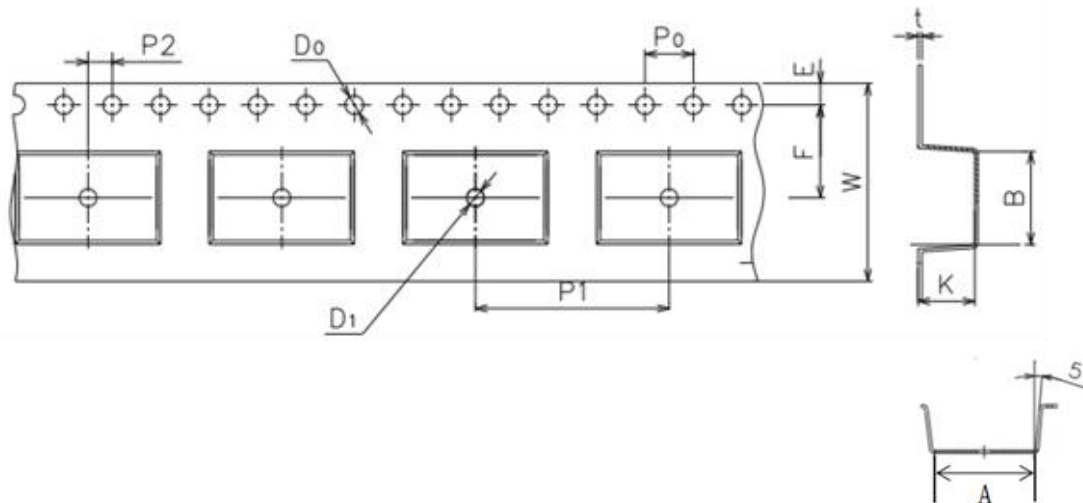

尺寸编号 Dimension No.	A	B	D0	D1	E	F
尺寸(mm) Dimension(mm)	10.4±0.1	10.0±0.1	1.5+0.1/-0	1.5±0.25	1.75±0.1	7.5±0.1
尺寸编号 Dimension No.	P0	P1	P2	t	W	K
尺寸(mm) Dimension(mm)	4.0±0.1	16.0±0.1	2.0±0.05	0.4±0.05	16.0±0.3	4.5±0.1

### 13. 焊接温度曲线 Temperature Profile Of Soldering

#### • 回流焊温度曲线 Reflow soldering

建议在下面所示的温度和时间分布条件下, 进行一次回流焊作业, 不得超过三次

One time soldering reflow is recommended within the condition of temperature and time profile shown below. Do not solder more than three times.

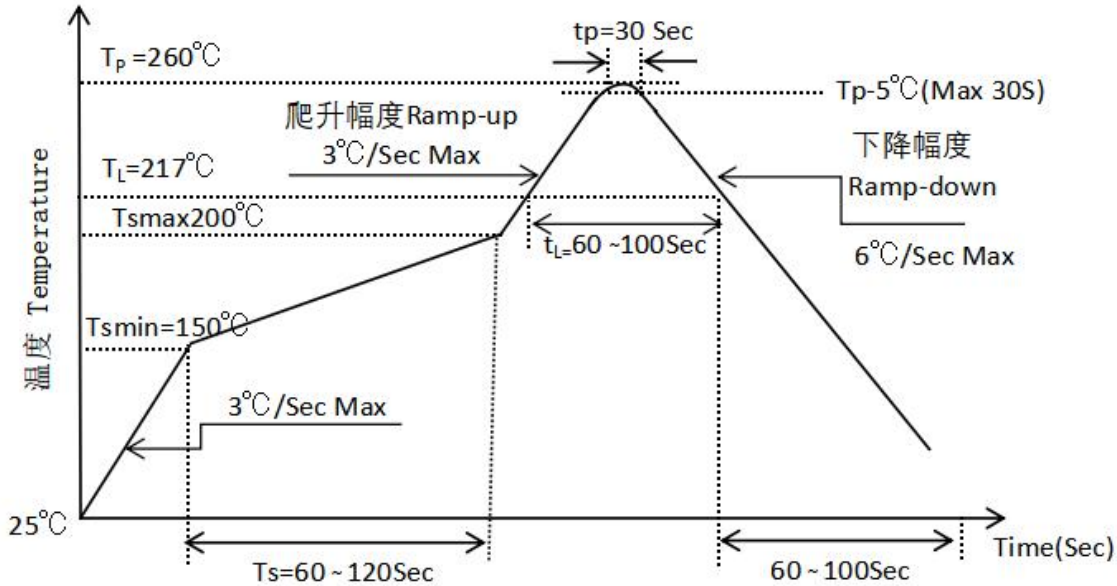

项目 Item	符号 Symbol	最小值 Min.	最大值 Max.	单位 Unit
预热温度 Preheat Temperature	$T_s$	150	200	$^{\circ}\text{C}$
预热时间 Preheat Time	$t_s$	60	120	s
升温速率 Ramp-Up Rate ( $T_L$ to $T_p$ )	-	-	3	$^{\circ}\text{C}/\text{s}$
液相线温度 Liquidus Temperature	$T_L$	217		$^{\circ}\text{C}$
高于液相线温度( $T_L$ )的时间 Time above Liquidus Temperature $T_L$	$t_L$	60	100	s
峰值温度 Peak Temperature	$T_p$	-	260	$^{\circ}\text{C}$
$T_c$ 在( $T_p-5$ )和 $T_p$ 之间的时间 Time During Which $T_c$ Is Between ( $T_p-5$ ) and $T_p$	$t_p$	-	30	s
降温速率 Ramp-down Rate( $T_p$ to $T_L$ )	-	-	6	$^{\circ}\text{C}/\text{s}$

### • 波峰焊温度曲线 Wave Soldering

温度条件下, 建议一次焊接

One time soldering is recommended within the condition of temperature

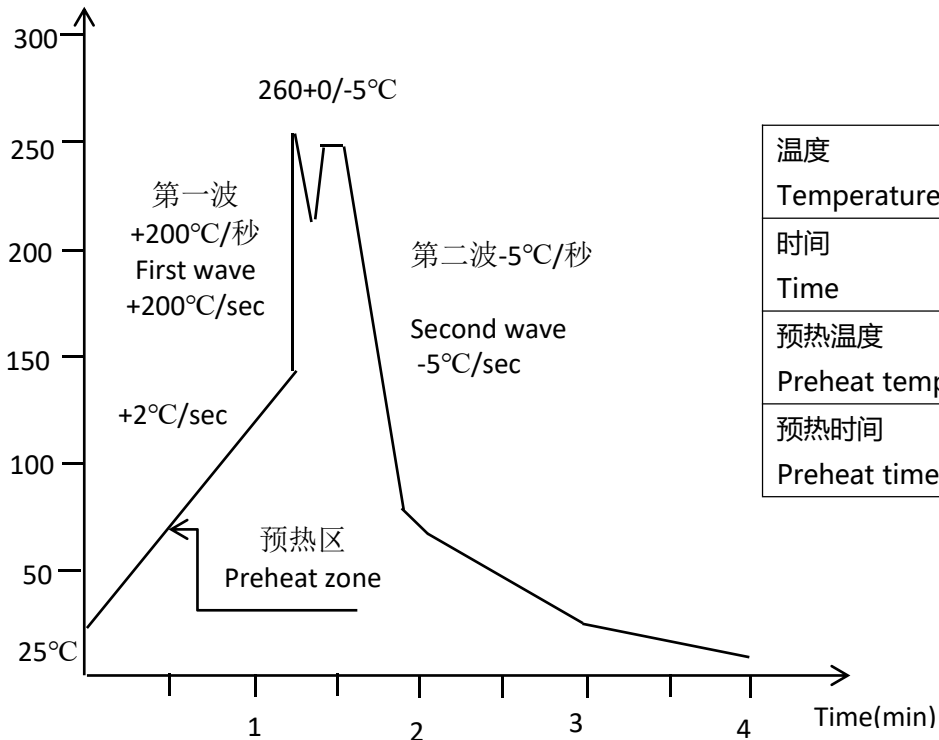

温度 Temperature	260°C+0/-5°C
时间 Time	10秒 10S
预热温度 Preheat temperature	25至140°C 25 to 140°C
预热时间 Preheat time	30至80秒 30 to 80 S

单击下面可查看定价，库存，交付和生命周期等信息

[>>Kinglight\(晶台\)](#)