

CD110 Series

Aluminum Electrolytic Capacitors

Item Name	Rating	Case size
CD1101H471M	50V470 μ F	D10X20L

1. Operating Temp. Range

-40+105°C

2. Electrical Characteristics

See Table 1.

【Table 1】

Rated Voltage VDC	Surge Voltage VDC	Nominal Static Capacitance (μ F)	Tolerance on Capacitance (%) 20°C 120Hz	Dissipation Factor (tan δ) max 20°C 120Hz	Leakage Current 2min. 20°C (μ A)	Permissible Ripple Current (mA rms) 105°C 120Hz	Impedance (Ω) 100KHz 20°C
50	63	470	\pm 20%	0.12	235	771	/

3. Dimensions

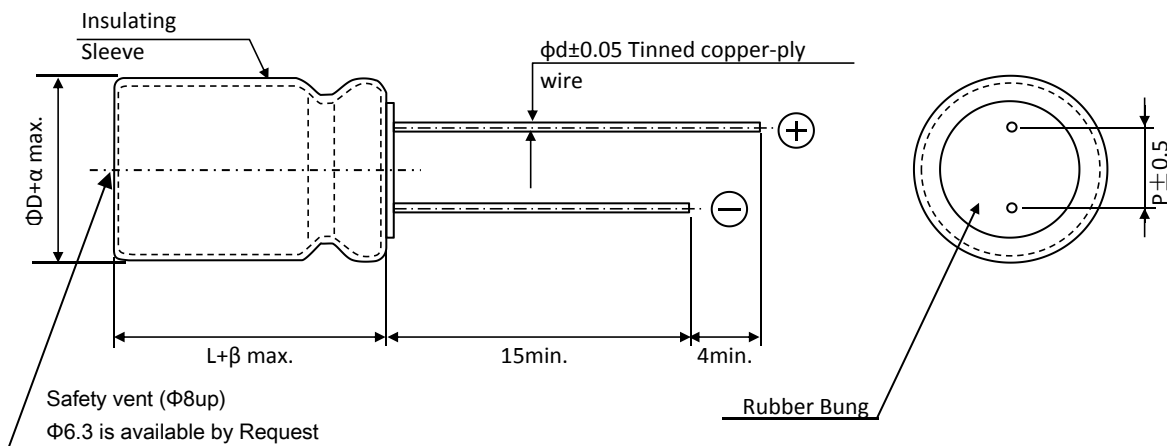

Unit(mm)

ϕD	α	L	β	ϕd	P
10	0.5	20.0	2.0	0.6	5.0

4. Marking

Following items are printed with white colour on black colour sleeve

Example of Marking

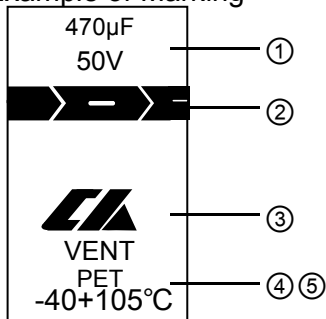

① Rated Voltage & Nominal Capacitance

② Polarity (negative)

③ Trade Mark of CH

④ Product Series

⑤ Operating Temp. Range

5. MULTIPLIER FOR RIPPLE CURRENT

①. Frequency Coefficient

Freq.(Hz)	50Hz	120Hz	300Hz	1KHz	10KHz	
Cap(μ F)	470	0.8	1	1.25	1.34	1.5

②. Temperature Coefficient

Ambient Temperature(°C)	40	60	70	85	105
Coefficient	2.4	2.1	1.78	1.65	1

6. Characteristics

No.	Item	Performance	Test Method																							
1	Leakage Current	$I \leq 235\mu A$	Protection Resistor: $1000 \pm 10\Omega$ Applied Volt: Rated Voltage Measuring time: 2 minutes																							
2	Static Capacitance	$\pm 20\%$	Measured Frequency: $120\text{Hz} \pm 20\%$ Measured Voltage: $\leq 0.5\text{Vrms}$, $1.5 \sim 2.0\text{VDC}$																							
3	Dissipation Factor (tan δ)	0.12 and Under	Same as condition of Capacitors																							
4	Load Life	<table border="1"> <tr> <td>Leakage Current</td> <td>\leq the value specified in Table 1</td> </tr> <tr> <td>Cap. Change</td> <td>$\leq \pm 20\%$ of initial value</td> </tr> <tr> <td>Dissipation Factor</td> <td>$\leq 200\%$ of value specified in Table 1</td> </tr> <tr> <td>Appearance</td> <td>No remarkable abnormality</td> </tr> </table>	Leakage Current	\leq the value specified in Table 1	Cap. Change	$\leq \pm 20\%$ of initial value	Dissipation Factor	$\leq 200\%$ of value specified in Table 1	Appearance	No remarkable abnormality	Test condition: $105 \pm 2^\circ\text{C}$ 120Hz Applied voltage: Rated voltage Applied Ripple Current: 771mArms Test Time: $2000 +72, -0$ hours															
Leakage Current	\leq the value specified in Table 1																									
Cap. Change	$\leq \pm 20\%$ of initial value																									
Dissipation Factor	$\leq 200\%$ of value specified in Table 1																									
Appearance	No remarkable abnormality																									
5	Shelf Life	<table border="1"> <tr> <td>Leakage Current</td> <td>\leq the value specified in Table 1</td> </tr> <tr> <td>Cap. Change</td> <td>$\leq \pm 20\%$ of initial value</td> </tr> <tr> <td>Dissipation Factor</td> <td>$\leq 200\%$ of value specified in Table 1</td> </tr> <tr> <td>Appearance</td> <td>No remarkable abnormality</td> </tr> </table>	Leakage Current	\leq the value specified in Table 1	Cap. Change	$\leq \pm 20\%$ of initial value	Dissipation Factor	$\leq 200\%$ of value specified in Table 1	Appearance	No remarkable abnormality	Test Temp. : $105 \pm 2^\circ\text{C}$ No voltage applied Test Time 1000 hours $+24, -0$ hours															
Leakage Current	\leq the value specified in Table 1																									
Cap. Change	$\leq \pm 20\%$ of initial value																									
Dissipation Factor	$\leq 200\%$ of value specified in Table 1																									
Appearance	No remarkable abnormality																									
6	Terminal Strength	<table border="1"> <tr> <td>Tensile Strength</td> <td>45N {4.5kg}</td> </tr> <tr> <td>Bending Strength</td> <td>25N {2.5kg}</td> </tr> </table>	Tensile Strength	45N {4.5kg}	Bending Strength	25N {2.5kg}	Keeping time Tensile: 1 ~ 5 sec Bending: 30 ± 5 sec																			
Tensile Strength	45N {4.5kg}																									
Bending Strength	25N {2.5kg}																									
7	Impedance Ratio	<table border="1"> <tr> <td>Z(-25°C) / Z(+20°C)</td> <td>2</td> </tr> <tr> <td>Z(-40°C) / Z(+20°C)</td> <td>3</td> </tr> </table>	Z(-25°C) / Z(+20°C)	2	Z(-40°C) / Z(+20°C)	3																				
Z(-25°C) / Z(+20°C)	2																									
Z(-40°C) / Z(+20°C)	3																									
8	Temperature Characteristics	<table border="1"> <thead> <tr> <th>Stage</th> <th>Item</th> <th>Performance</th> </tr> </thead> <tbody> <tr> <td>2,3</td> <td>Impedance Ratio</td> <td>less than the value mentioned in 6-7</td> </tr> <tr> <td>5</td> <td>Cap. Change</td> <td>$\leq \pm 25\%$ against value in stage 4</td> </tr> </tbody> </table> <p>After the capacitor is held at temperature of each stage and reaches temperature stability, measure performance.</p>	Stage	Item	Performance	2,3	Impedance Ratio	less than the value mentioned in 6-7	5	Cap. Change	$\leq \pm 25\%$ against value in stage 4	<table border="1"> <thead> <tr> <th>Stage</th> <th>Test Temp(°C)</th> </tr> </thead> <tbody> <tr> <td>1</td> <td>20 ± 2</td> </tr> <tr> <td>2</td> <td>-25 ± 3;</td> </tr> <tr> <td>3</td> <td>-40 ± 3;</td> </tr> <tr> <td>4</td> <td>20 ± 2</td> </tr> <tr> <td>5</td> <td>105 ± 2</td> </tr> <tr> <td>6</td> <td>20 ± 2</td> </tr> </tbody> </table>	Stage	Test Temp(°C)	1	20 ± 2	2	-25 ± 3 ;	3	-40 ± 3 ;	4	20 ± 2	5	105 ± 2	6	20 ± 2
Stage	Item	Performance																								
2,3	Impedance Ratio	less than the value mentioned in 6-7																								
5	Cap. Change	$\leq \pm 25\%$ against value in stage 4																								
Stage	Test Temp(°C)																									
1	20 ± 2																									
2	-25 ± 3 ;																									
3	-40 ± 3 ;																									
4	20 ± 2																									
5	105 ± 2																									
6	20 ± 2																									
9	Surge Voltage	<table border="1"> <thead> <tr> <th>Item</th> <th>Performance</th> </tr> </thead> <tbody> <tr> <td>Leakage Current</td> <td>\leq the initial specified value</td> </tr> <tr> <td>Cap. Change</td> <td>$\leq \pm 15\%$ against value before test</td> </tr> <tr> <td>Dissipation Factor</td> <td>\leq the initial specified value</td> </tr> <tr> <td>Appearance</td> <td>No remarkable abnormality</td> </tr> </tbody> </table>	Item	Performance	Leakage Current	\leq the initial specified value	Cap. Change	$\leq \pm 15\%$ against value before test	Dissipation Factor	\leq the initial specified value	Appearance	No remarkable abnormality	Test Temp.: $15 \sim 35^\circ\text{C}$ Test volt.: Surge Volt. Specified in 2 Voltage apply 1,000 times of charge for 30 ± 5 sec, under frequency of 6 ± 0.5 sec, and discharge for 5min 30sec.													
Item	Performance																									
Leakage Current	\leq the initial specified value																									
Cap. Change	$\leq \pm 15\%$ against value before test																									
Dissipation Factor	\leq the initial specified value																									
Appearance	No remarkable abnormality																									
10	Vibration Resistance	<table border="1"> <tr> <td>Capacitance</td> <td>Stability required</td> </tr> <tr> <td>Cap. Change</td> <td>$\leq \pm 5\%$ of the initial specified value</td> </tr> <tr> <td>Appearance</td> <td>No remarkable abnormality</td> </tr> </table>	Capacitance	Stability required	Cap. Change	$\leq \pm 5\%$ of the initial specified value	Appearance	No remarkable abnormality	Frequency: $10 \sim 55\text{Hz}$ Width of vibration: 1.5mm Direction and duration: X,Y and Z directions, each for 2 hours																	
Capacitance	Stability required																									
Cap. Change	$\leq \pm 5\%$ of the initial specified value																									
Appearance	No remarkable abnormality																									
11	Solderbility	3/4 area of surrounding directions of surface should be covered with new solder.	Solder: Sn-Ag, Sn-Cu Type Soldering Temp: $240 \pm 5^\circ\text{C}$ Dipping degree: $2 \sim 2.5\text{mm}$ Flux: Ethanol solution (JIS K8101) or Isopropylalcohol (JIS K8839) solution of Rosin (JIS K5902)																							
12	Resistance to Soldering	<table border="1"> <tr> <td>Leakage Current</td> <td>\leq the initial specified value</td> </tr> <tr> <td>Cap. Change</td> <td>$\leq \pm 15\%$ against value before test</td> </tr> <tr> <td>Dissipation Factor</td> <td>\leq the initial specified value</td> </tr> <tr> <td>Appearance</td> <td>No remarkable abnormality</td> </tr> </table>	Leakage Current	\leq the initial specified value	Cap. Change	$\leq \pm 15\%$ against value before test	Dissipation Factor	\leq the initial specified value	Appearance	No remarkable abnormality	Soldering Temp. $280 \pm 5^\circ\text{C}$ Soldering Time . 10 ± 1 sec.															
Leakage Current	\leq the initial specified value																									
Cap. Change	$\leq \pm 15\%$ against value before test																									
Dissipation Factor	\leq the initial specified value																									
Appearance	No remarkable abnormality																									

6-2. Characteristics

No.	Item	Performance	Test Method								
13	Resistance to Humidity	<table border="1"> <tr> <td>Leakage Current</td> <td>≤ Initial specified value</td> </tr> <tr> <td>Cap. Change</td> <td>≤ ±15% of initial value</td> </tr> <tr> <td>Dissipation Factor</td> <td>≤ Initial specified value</td> </tr> <tr> <td>Appearance</td> <td>No remarkable abnormality</td> </tr> </table>	Leakage Current	≤ Initial specified value	Cap. Change	≤ ±15% of initial value	Dissipation Factor	≤ Initial specified value	Appearance	No remarkable abnormality	Test Temp. : 40±2°C Humidity 90 ~ 95% Test Time : 500 ± 8 hours After the above condition, restored to normal temp, and then measured.
Leakage Current	≤ Initial specified value										
Cap. Change	≤ ±15% of initial value										
Dissipation Factor	≤ Initial specified value										
Appearance	No remarkable abnormality										
14	Pressure valve moment characteristics	Pressure valve open safely. There must be nothing ignition or scattering from product.	DC method: Apply an reverse current of 1A to impress the reverse voltage until pressure valve open.								

7. Packing method

Packaging shape, size, quantity

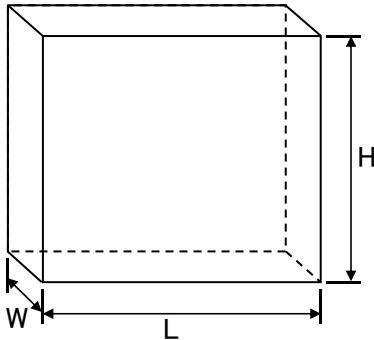

Component size	D10X20L
Quantity per case	PCS
Symbol of box	Y-2
L	480
H	320
W	320

8 Related Standards: JIS C 5141

9 Marking on packing box

- ① Item name
- ② Series name
- ③ Rated Voltage
- ④ Nominal Static Capacitance
- ⑤ Case size
- ⑥ Lot No.
- ⑦ Quantity

10 Soldering

10-1 Soldering by soldering iron

Temperature of iron top : 270~350°C

Operating time : within 3 sec.

10-2 Flow soldering.

Preheat : PCB surface temperature 120°C±5°C

Solder temp.: 260°C±5°C

Solder dipping time: 2~4sec.

11 Cleaning of PC board after soldering

Some solvents is acceptable but make sure following condition:

Solvent:

IPA or Alcoholic agent like Pinealpha ST-100S, Cleanthrough 750H, 750L, 710M, 750K, or Technocare FRW-14 ~ 17

- ① Cleaning should be made by ultrasonic within 5min, at the temperature less then 60°C.
- ② Control of pollution is necessary.
- ③ Keep away from cleaning agent. Please do not store in air-tight container.
Dry it by hot air, keep the temperature of air less than maximum operating temp.

单击下面可查看定价，库存，交付和生命周期等信息

[>>KINGTOP\(勤拓\)](#)