

CD288H Series

Aluminum Electrolytic Capacitors

Item Name	Rating	Case size
CD288H1H332M	50V3300	18X40

1. Operating Temp. Range

-40°C ~ +105°C

2. Electrical Characteristics

See Table 1.

Rated Voltage VDC	Surge Voltage VDC	Nominal Static Capacitance	Tolerance on Capacitance(%) 20°C 120Hz	Dissipation Factor (tanδ)max 20°C 120Hz	Leakage Current 2min. 20°C (μA)	Permissible Ripple Current (mArms)	Impedance (Ω) √100KHz/ 25°C
50	63	3300	-20~+20	0.14	1650	2,150	\

【Table 1】

3. Dimensions

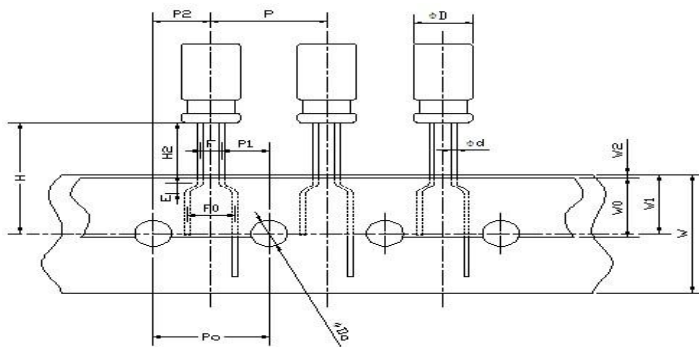

Unit(mm)

$\phi D+0.5\text{Max}$	$L+1.0\text{Max}$	$F\pm 0.5$	$d\pm 0.05$
18	40	7.5	0.8

4. Marking

Following items are printed with white color on black color sleeve

Example of

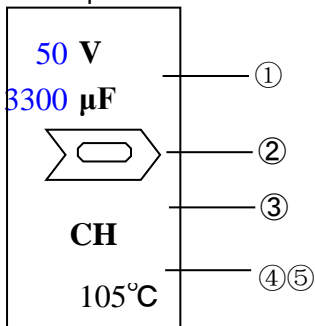

- ① Rated voltage & Nominal Capacitance
- ② Polarity (negative)
- ③ Trade Mark
- ④ Symbol of Capacitance Tolerance (M)
- ⑤ Max Operating Temp.

5. MULTIPLIER FOR RIPPLE CURRENT

①. Frequency Coefficient

Freq.(Hz)	60(50)	120	300	1K	10K
Cap(μF)					
3300	0.8	1	1.25	1.34	1.5

②. Temperature Coefficient

Ambient Temperature(°C)	40	60	70	85	105
Coefficient	2.4	2.1	1.78	1.65	1

6. Characteristics

No.	Item	Performance	Test Method			
1	Leakage Current	I= 1650 μ A Whichever is smaller (After 2 min)	Protection Resistor : 1000 \pm 10 Ω Applied Volt : Rated Voltage Measuring time : 2minutes			
2	Static Capacitance	-20+20%	Measured Frequency : 120Hz \pm 20% Measured Voltage \leq 0.5Vrms, 1.5 ~ 2.0VDC			
3	Dissipation Factor (tan δ)	0.14 and Under	Same as condition of Capacitors			
4	High Temp. Load Characteristics	Leakage Current	\leq the value specified in Table 1			
		Cap. Change	\leq \pm 20% of initial value			
		Dissipation Factor	\leq 200% of value specified in Table 1			
		Appearance	No remarkable abnormality			
		Test Temp. : 105 \pm 2 $^{\circ}$ C Applied voltage: Rated voltage Test Tin 3000 hours +72, -0 hours				
5	High Temp. no load Characteristics	Leakage Current	\leq the value specified in Table 1			
		Cap. Change	\leq \pm 20% of initial value			
		Dissipation Factor	\leq 200% of value specified in Table 1			
		Appearance	No remarkable abnormality			
		Test Temp. : 105 \pm 2 $^{\circ}$ C No voltage applied Test Tin 1500 hours +24, -0 hours				
6	Terminal Strength	Tensile Strength	45N {4.5kg}			
		Bending Strength	25N {2.5kg}			
		Keeping time Tensile 1~5sec Bending 30 \pm 5sec				
7	Impedance Ratio	W V	50			
		Z(-25 $^{\circ}$ C)/Z(+20 $^{\circ}$ C)	2			
		Z(-40 $^{\circ}$ C)/Z(+20 $^{\circ}$ C)	3			
8	Temperature Characteristics	Stage	Item	Performance	Stage	Test Temp($^{\circ}$ C)
		2,3	Impedance Ratio	less than the value mentioned in 5-7,	1	20 \pm 2
		5	Cap, Change	\leq \pm 25% against value in stage 4	2	-25 \pm 3
		After the capacitor is held at temperature of each stage and reaches temperature stability, measure performance.			3	-40 \pm 3
					4	20 \pm 2
					5	105 \pm 2
6	20 \pm 2					
9	Surge Voltage	Item	Performance			
		Leakage Current	\leq the initial specified value			
		Cap, Change	\leq \pm 15% against value before test			
		Dissipation Factor	\leq the initial specified value			
		Appearance	No remarkable abnormality			
Test Temp. 15~35 $^{\circ}$ C Test volt. Surge Volt.Specified in 2 Voltage apply. 1,000times of charge for 30 \pm 5sec, under frequency of 6 \pm 0.5sec, and discharge for 5min30sec.						

6-2. Characteristics

No.	Item	Performance	Test Method								
10	Vibration Resistance	<table border="1"> <tr> <td>Capacitance</td> <td>Stability required</td> </tr> <tr> <td>Cap. Change</td> <td>$\leq \pm 5\%$ of the initial specified value</td> </tr> <tr> <td>Appearance</td> <td>No remarkable abnormality</td> </tr> </table> <p>Frequency : 10~55Hz/1min. Width of vibration, 1.5mm Direction and duration X, Y and Z directions, each for 2 hours (Total 9 hours)</p>	Capacitance	Stability required	Cap. Change	$\leq \pm 5\%$ of the initial specified value	Appearance	No remarkable abnormality			
Capacitance	Stability required										
Cap. Change	$\leq \pm 5\%$ of the initial specified value										
Appearance	No remarkable abnormality										
11	Solderbilty	3/4 area of surrounding directions of surface should be covered with new solder.	<p>Solder: Sn-Ag, Sn-Cu Type Soldering Temp : $240 \pm 5^{\circ}\text{C}$ Dipping degree : 2~2.5mm Flux : Ethanol solution (JIS K8101) or Isopropylalchol (JIS K8839) solution of Rosin (JIS K5902)</p>								
12	Resistance to Soldering	<table border="1"> <tr> <td>Leakage Current</td> <td>\leq Initial specified value</td> </tr> <tr> <td>Cap. Change</td> <td>$\leq \pm 10\%$ of initial value</td> </tr> <tr> <td>Dissipation Factor</td> <td>\leq Initial specified in value</td> </tr> <tr> <td>Appearance</td> <td>No remarkable abnormality</td> </tr> </table>	Leakage Current	\leq Initial specified value	Cap. Change	$\leq \pm 10\%$ of initial value	Dissipation Factor	\leq Initial specified in value	Appearance	No remarkable abnormality	<p>Soldering Temp. $280 \pm 5^{\circ}\text{C}$ Soldering Time . 10 ± 1sec.</p>
Leakage Current	\leq Initial specified value										
Cap. Change	$\leq \pm 10\%$ of initial value										
Dissipation Factor	\leq Initial specified in value										
Appearance	No remarkable abnormality										
13	Resistance to Humidity	<table border="1"> <tr> <td>Leakage Current</td> <td>\leq Initial specified value</td> </tr> <tr> <td>Cap. Change</td> <td>$\leq \pm 15\%$ of initial value</td> </tr> <tr> <td>Dissipation Factor</td> <td>\leq Initial spesified value</td> </tr> <tr> <td>Appearance</td> <td>No remarkable abnormality</td> </tr> </table>	Leakage Current	\leq Initial specified value	Cap. Change	$\leq \pm 15\%$ of initial value	Dissipation Factor	\leq Initial spesified value	Appearance	No remarkable abnormality	<p>Test Temp. : $40 \pm 2^{\circ}\text{C}$ Humidity 90~95% Test Time : 500 ± 8 hours After the above condition,restored to normal temp, and then measured.</p>
Leakage Current	\leq Initial specified value										
Cap. Change	$\leq \pm 15\%$ of initial value										
Dissipation Factor	\leq Initial spesified value										
Appearance	No remarkable abnormality										
14	Perssure valv moment charact-erstics	There must not be thing ignition, scattering the resolution that that case works safely	Dcmethod: impress the reverse voltage and of 1A, I cancel an electric current.								

7.Packing method

5-1 Packaging shape, size, quantity

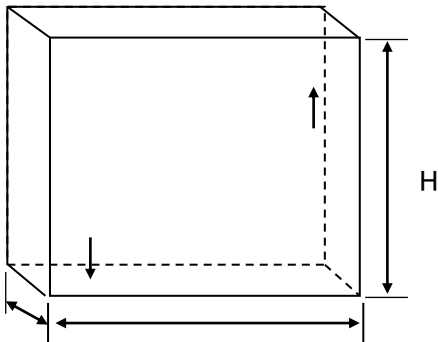

Componen t	Quantity per	Symbol of box	L	H	W
18X40	PCS	Y-2	480	320	320

8 W Related Standards JIS C 5141

9 Marking on packing box

- ① Item name
- ② Series name
- ③ Rated Voltage
- ④ Nominal Static Capacitance
- ⑤ Case size
- ⑥ Lot No.
- ⑦ Quantity

10 Soldering

8-1 Soldering by soldering iron

Temperature of iron top : 270~350°C

Operating time : within 3 sec.

8-2 Flow soldering.

Preheat : PCB surface temperature 120°C ±5°C

Solder Temp : 260°C ±5°C

Solder Dipping Temp. : 2~4sec.

11 Cleaning of PC board after soldering

Using following solvents is possible but make sure following condition

Solvent

IPA or Alcoholic agent like Pinealpha ST-100S, Cleanthrough 750H, 750L, 710M, 750K,
or Technocare FRW-14~17

- ① Cleaning should be made by ultrasonic within 5min, at the temperature less than 60°C.
- ② Control of pollution is necessary (conductivity,pH, specific gravity, water volume)
- ③ Please do not keep near cleaning agent. Please do not store in air-tight container.
Please let it dry by hot air at the temperature less than maximum operating temp.

单击下面可查看定价，库存，交付和生命周期等信息

[>>KINGTOP\(勤拓\)](#)