

**150mW SOT-523 SURFACE MOUNT**  
**Plastic Package**  
**N-Channel MOSFET**

**Absolute Maximum Ratings**  $T_A = 25^\circ\text{C}$  unless otherwise noted

Symbol	Parameter	Value	Units
$V_{DS}$	Drain-Source Voltage	30	V
$V_{GS}$	Continuous Gate-Source Voltage	$\pm 20\text{V}$	V
$I_D$	Continuous Drain Current	100	mA
$P_D$	Power Dissipation	150	mW
$R_{\theta JA}$	Thermal Resistance from Junction to Ambient	833	$^\circ\text{C}/\text{W}$
$T_{STG}$	Storage Temperature Range	-55 to +150	$^\circ\text{C}$
$T_J$	Operating Junction Temperature	+150	$^\circ\text{C}$

These ratings are limiting values above which the serviceability of the device may be impaired.

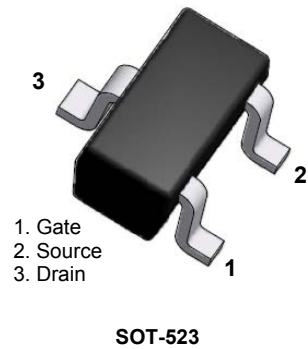

**SOT-523**

**Specification Features:**

- Low On-resistance
- Fast Switching Speed
- Low Voltage Drive Makes This Device Ideal for Portable Equipment
- Easily Designed Drive Circuits
- Easy to Parallel
- RoHS Compliant & Green EMC
- Matte Tin(Sn) Lead Finish
- Weight: approx. 0.002g

**Electrical Symbol:**

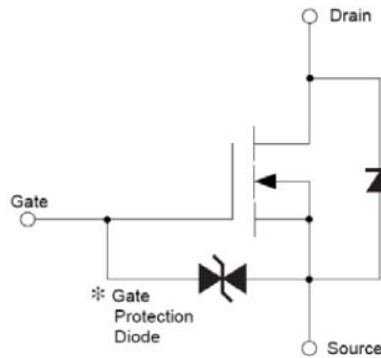

**Device Marking Code:**

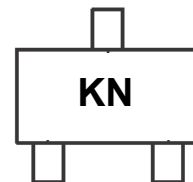

**Electrical Characteristics** ( $T_A = 25^\circ\text{C}$  unless otherwise noted)

**Off Characteristics**

Symbol	Parameter	Test Condition	Limits			Unit
			Min	Typ	Max	
$BV_{DSS}$	Drain-Source Breakdown Voltage	$V_{GS}=0V, I_D=10\mu A$	30			Volts
$I_{GSS}$	Gate-Body Leakage	$V_{DS}=0V, V_{GS}=\pm 20V$			$\pm 1$	$\mu A$
$I_{DSS}$	Zero Gate Voltage Drain Current	$V_{DS}=30V, V_{GS}=0V$			1	$\mu A$

**On Characteristics**

Symbol	Parameter	Test Condition	Limits			Unit
			Min	Typ	Max	
$V_{th(GS)}$	Gate-Threshold Voltage	$V_{DS}=3V, I_D=100\mu A$	0.8		1.5	Volts
$R_{DS(on)}$	Drain-Source On-Resistance	$V_{GS}=4V, I_D=10mA$			8	$\Omega$
		$V_{GS}=2.5V, I_D=1mA$			13	$\Omega$
$g_{fs}$	Forward Trans Conductance	$V_{DS}=3V, I_D=10mA$	20			ms
$V_{SD}$	Drain-Source Diode Forward Voltage	$I_S=115mA, V_{GS}=0V$			1.2	V

**Dynamic Characteristics**

Symbol	Parameter	Test Condition	Limits			Unit
			Min	Typ	Max	
$C_{iss}$	Input Capacitance	$V_{DS}=5V$ $V_{GS}=0V$ $f=1.0MHz$		13		pF
$C_{oss}$	Output Capacitance			9		pF
$C_{rss}$	Reverse Transfer Capacitance			4		pF

**Switching Characteristics**

Symbol	Parameter	Test Condition	Limits			Unit
			Min	Typ	Max	
$t_{D(on)}$	Turn-on Time	$V_{DD}=5V, R_L=500\Omega,$ $I_D=10mA, V_{GS}=5V,$ $R_G=10\Omega$		15		nS
$t_{D(off)}$	Turn-off Time			80		nS

**SOT-523 Package Outline**

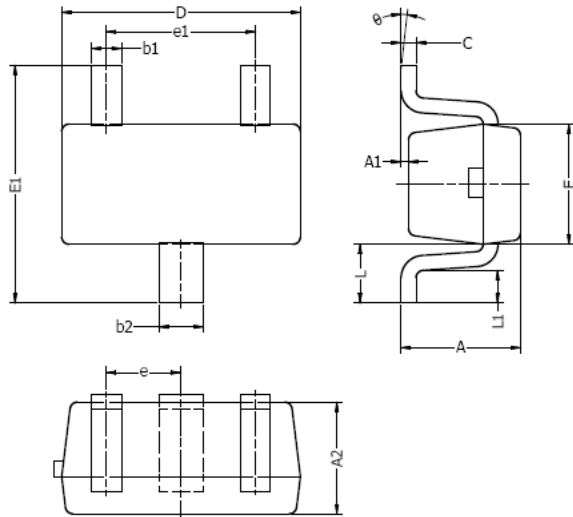

DIM	MILLIMETERS		INCHES	
	MIN	MAX	MIN	MAX
A	0.70	0.90	0.028	0.035
A1	0.00	0.10	0.000	0.004
A2	0.70	0.80	0.028	0.031
b1	0.15	0.25	0.006	0.010
b2	0.25	0.35	0.010	0.014
c	0.10	0.20	0.004	0.008
D	1.50	1.70	0.059	0.067
E	0.70	0.90	0.028	0.035
E1	1.45	1.75	0.057	0.069
e	0.50 TYP.		0.020 TYP.	
e1	0.90	1.10	0.035	0.043
L	0.40 REF.		0.016 REF.	
L1	0.10	0.30	0.004	0.012
theta	0°	8°	0°	8°

**Typical Soldering Pattern:**

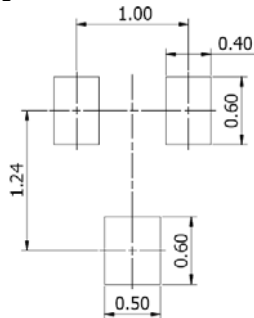

**NOTES:**

1. Above package outline conforms to JEITA EAIJ ED-7500A SC-75A.
2. Dimensions are exclusive of Burrs, Mold Flash & Tie Bar extrusions.

单击下面可查看定价，库存，交付和生命周期等信息

[>>KUU\(永裕泰\)](#)