

N-Channel 30-V(D-S) MOSFET

| V(BR)DSS | RDS(on)MAX | ID |
|----------|------------|------|
| 30 V | 65mΩ@10V | 3.5A |
| | 90mΩ@4.5V | |

FEATURE

- ※ TrenchFET Power MOSFET

APPLICATION

- ※ Load Switch for Portable Devices
- ※ DC/DC Converter

MARKING

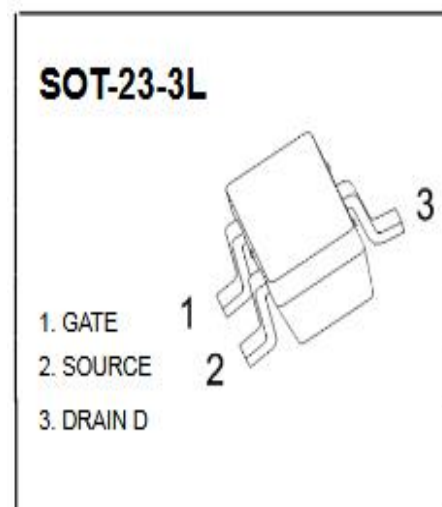
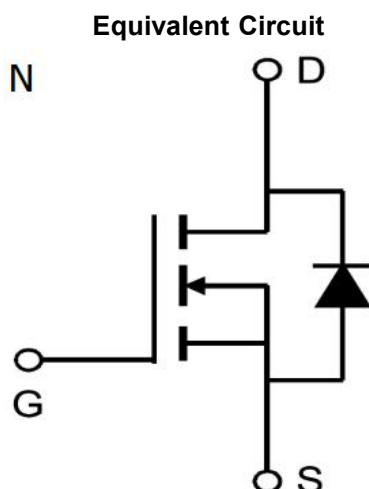
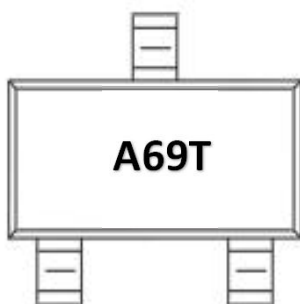

Maximum ratings (Ta=25°C unless otherwise noted)

| Parameter | Symbol | Value | Unit |
|--|--------|----------|------|
| Drain-Source Voltage | VDS | 30 | V |
| Gate-Source Voltage | VGS | ±20 | |
| Continuous Drain Current | ID | 3.5 | A |
| Pulsed Diode Curren | IDM | 20 | |
| Continuous Source-Drain Current(Diode Conduction) | IS | 0.8 | |
| Power Dissipation | PD | 0.75 | W |
| Thermal Resistance from Junction to Ambient (t≤5s) | RθJA | 150 | °C/W |
| Operating Junction | TJ | 150 | °C |
| Storage Temperature | TSTG | -55~+150 | °C |

MOSFET ELECTRICAL CHARACTERISTICS
Static Electrical Characteristics (Ta = 25 °C Unless Otherwise Noted)

| Parameter | Symbol | Test Condition | Min | Typ | Max | Unit |
|--|----------|---|-----|-----|------|------|
| Static | | | | | | |
| Drain-source breakdown voltage | V(BR)DSS | VGS = 0V, ID = 250μA | 30 | | | V |
| Gate-source threshold voltage | VGS(th) | VDS = VGS, ID = 250μA | 1 | | 3 | V |
| Gate-source leakage | IGSS | VDS = 0V, VGS = ±20V | | | ±100 | nA |
| Zero gate voltage drain current | IDSS | VDS = 30V, VGS = 0V | | | 1 | μA |
| Drain-source on-state resistancea | RDS(on) | VGS = 10V, ID = 3.5A | | 40 | 65 | mΩ |
| | | VGS = 4.5V, ID = 2.8A | | 53 | 90 | mΩ |
| Forward transconductancea | gfs | VDS = 4.5V, ID = 3.5A | | 7 | | S |
| Diode forward voltage | VSD | IS = 1.25A, VGS = 0V | | 0.8 | 1.3 | V |
| Dynamic | | | | | | |
| Input capacitance | Ciss | VDS = 15V, VGS = 0V, f = 1MHz | | 305 | | pF |
| Output capacitance | Coss | | | 65 | | pF |
| Reverse transfer capacitanceb | Crss | | | 29 | | pF |
| Total gate charge | Qg | VDS = 18V, VGS = 4.5V, ID = 3.5A | | 3 | 4.5 | nC |
| Gate-source charge | Qgs | | | 1.6 | | nC |
| Gate-drain charge | Qgd | | | 0.6 | | nC |
| Gate resistance | Rg | f = 1MHz | | 5 | | Ω |
| Switchingb | | | | | | |
| Turn-on delay time | td(on) | VDD = 10V RL = 10Ω, ID ≈ 3A, VGEN = 4.5V, Rg = 6Ω | | 7 | 11 | ns |
| Rise time | tr | | | 12 | 18 | ns |
| Turn-off delay time | td(off) | | | 14 | 25 | ns |
| Fall time | tf | | | 6 | 10 | ns |
| Drain-source body diode characteristics | | | | | | |
| Continuous Source-Drain Diode Current | IS | Tc = 25°C | | | 1.3 | A |
| Pulsed Diode forward Curren | ISM | | | | 20 | A |

Note :

1. Repetitive Rating : Pulse width limited by maximum junction temperature.
2. Surface Mounted on FR4 Board, t < 5 sec.
3. Pulse Test : Pulse Width ≤ 300μs, Duty Cycle ≤ 2%.
4. Guaranteed by design, not subject to production testing.

SOT-23-3L PACKAGE OUTLINE DIMENSIONS

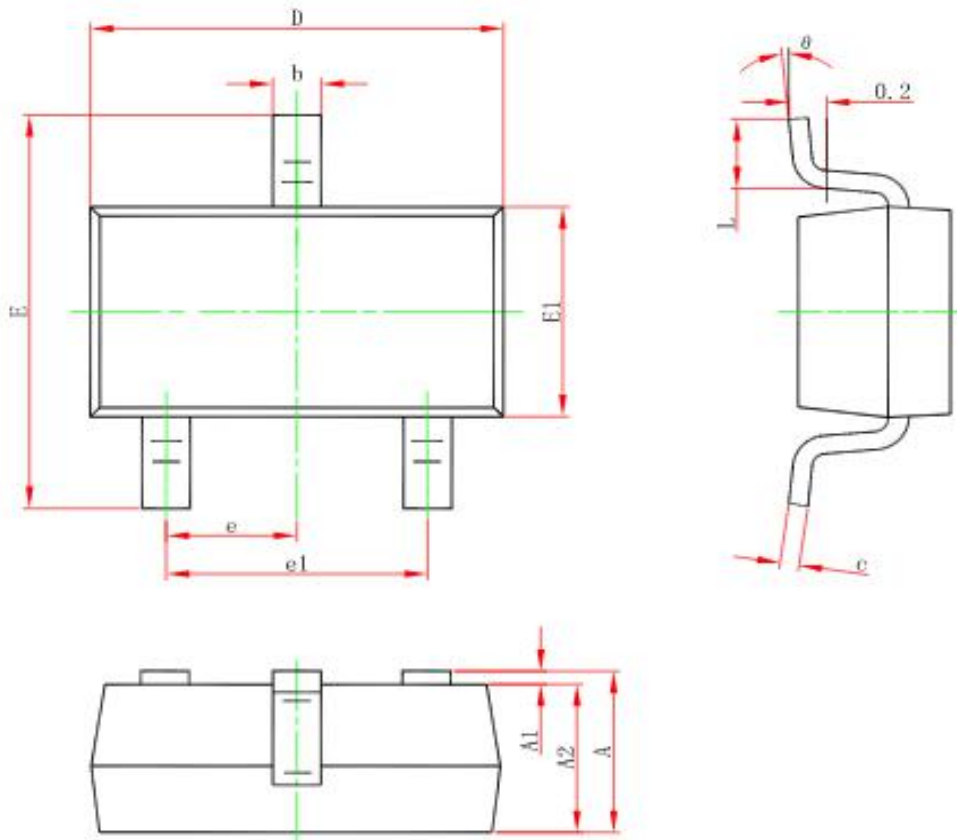

| Symbol | Dimensions In Millimeters | | Dimensions In Inches | |
|--------|---------------------------|-------|----------------------|-------|
| | Min. | Max. | Min. | Max. |
| A | 1.050 | 1.250 | 0.041 | 0.049 |
| A1 | 0.000 | 0.100 | 0.000 | 0.004 |
| A2 | 1.050 | 1.150 | 0.041 | 0.045 |
| b | 0.300 | 0.500 | 0.012 | 0.020 |
| c | 0.100 | 0.200 | 0.004 | 0.008 |
| D | 2.820 | 3.020 | 0.111 | 0.119 |
| E1 | 1.500 | 1.700 | 0.059 | 0.067 |
| E | 2.650 | 2.950 | 0.104 | 0.116 |
| e | 0.950(BSC) | | 0.037(BSC) | |
| e1 | 1.800 | 2.000 | 0.071 | 0.079 |
| L | 0.300 | 0.600 | 0.012 | 0.024 |
| θ | 0° | 8° | 0° | 8° |

单击下面可查看定价，库存，交付和生命周期等信息

[>>KUU\(永裕泰\)](#)