

## Revision History

Rev.No.	Description of revise	Date	Approved by	Checked by	Issued by
1	First Edition	May,16,2014	Y.Takahashi	T. Nitoube	Y. Kikuchi

**[PART NUMBER LIST]**

Nominal Frequency (MHz)	KYOCERA Part Number	ESR ( $\Omega$ )	Nominal Frequency Code
13.560	CX3225SB13560D0FPLCC	80	13560
16.000	CX3225SB16000D0FPLCC	80	16000
19.200	CX3225SB19200D0FPLCC	80	19200
20.000	CX3225SB20000D0FPLCC	50	20000
24.000	CX3225SB24000D0FPLCC	50	24000
25.000	CX3225SB25000D0FPLCC	50	25000
27.000	CX3225SB27000D0FPLCC	50	27000
30.000	CX3225SB30000D0FPLCC	50	30000
32.000	CX3225SB32000D0FPLCC	50	32000
38.400	CX3225SB38400D0FPLCC	50	38400
40.000	CX3225SB40000D0FPLCC	50	40000
48.000	CX3225SB48000D0FPLCC	50	48000

### 1. APPLICATION

This specification sheet is applied to quartz crystal "CX3225SB"

### 2. KYOCERA PART NUMBER

Refer to UKY1C-H1-14572-00[43] 3/11 Nominal Frequency

### 3. RATINGS

Items	SYMB.	Rating	Unit	Remarks
Operating Temperature	Topr	-40 to +85	°C	
Storage Temperature range	Tstg	-40 to +85	°C	

### 4. CHARACTERISTICS

#### ELECTRICAL CHARACTERISTICS

Items	Electrical Specification					Test Condition	Remarks
	SYMB.	Min	Typ.	Max	Unit		
Mode of Vibration		Fundamental					
Nominal Frequency	F0		※1		MHz		
Nominal Temperature	T <sub>NOM</sub>		+25		°C		
Load Capacitance	CL		8.0		pF		
Frequency Tolerance	df/F	-10.0		+10.0	PPM	+25±3°C	
Frequency Temperature characteristics	df/F	-20.0		+20.0		-40 to +85°C	
Frequency Aging Rate		-1.0		+1.0		1 year	+25±3°C
Equivalent Series Resistance	ESR			※2	Ω		
Drive Level	Pd	0.01		100	μW		
Insulation Resistance	IR	500			MΩ	100V(DC)	

※1 Refer to UKY1C-H1-14572-00[43] 3/11 Nominal Frequency

※2 Refer to UKY1C-H1-14572-00[43] 3/11 ESR

**5. APPEARANCES, PHYSICAL DIMENSION**  
**OUTLINE DIMENSION (not to scale)**

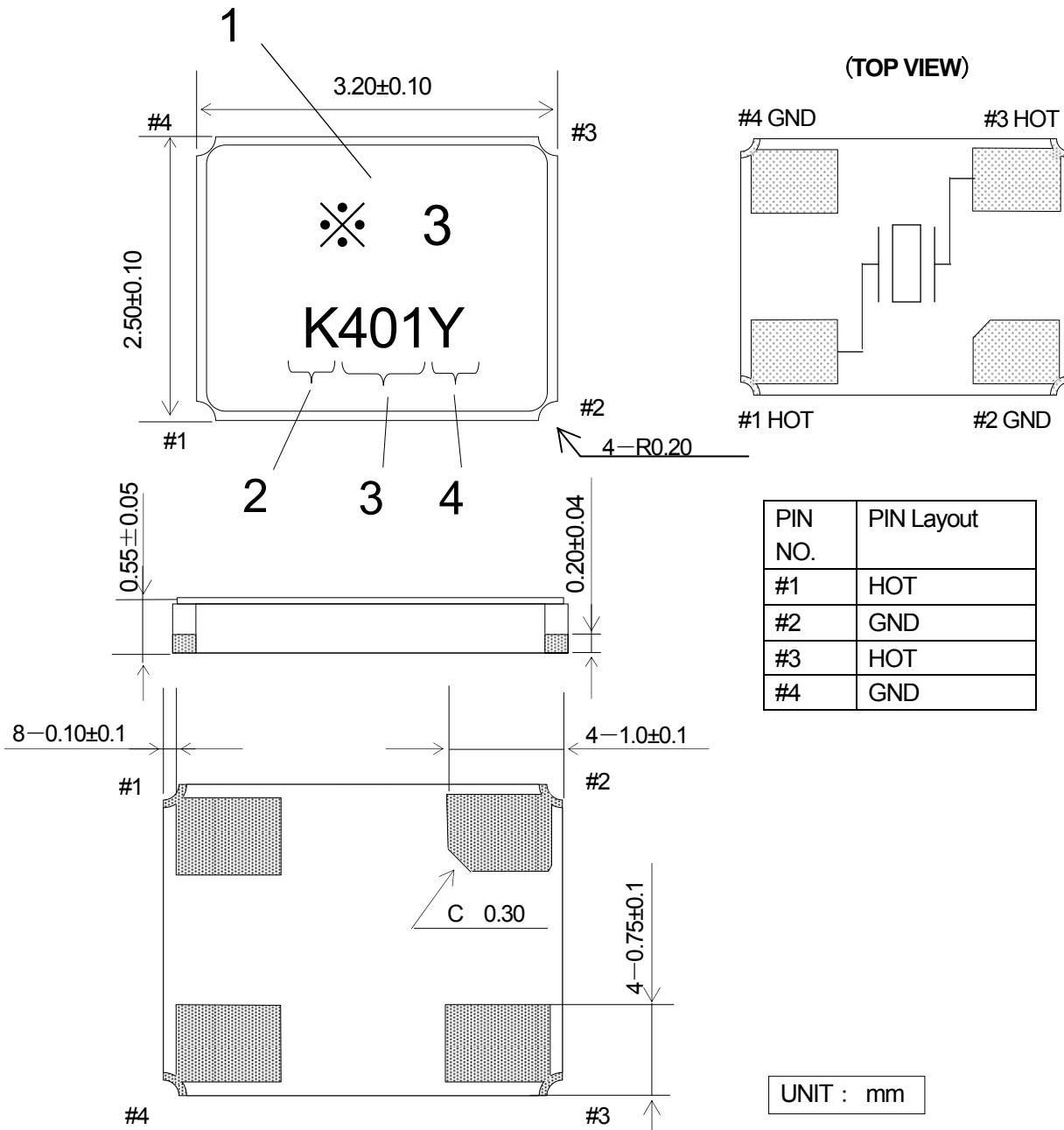

**MARKING**

- 1 Nominal Frequency Move the number of maximum indication beams of the frequency to five digits, and omit less than kHz.
- 2 Identification [K] mark is surely 1Pin direction.
- 3 Date Code Year··LAST 1 DIGIT of YEAR AND WEEK  
(Ex)Jan, 01, 2014 → 401
- 4 Manufacturing Location  
 Y··Yamagata  
 Z··Shiga Yohkaichi  
 T··Thailand  
 F··Philippines

※3 Refer to UKY1C-H1-14572-00[43] 3/11 Nominal Frequency Code

※The font of marking is reference.

KYOCERA Crystal Device Corporation

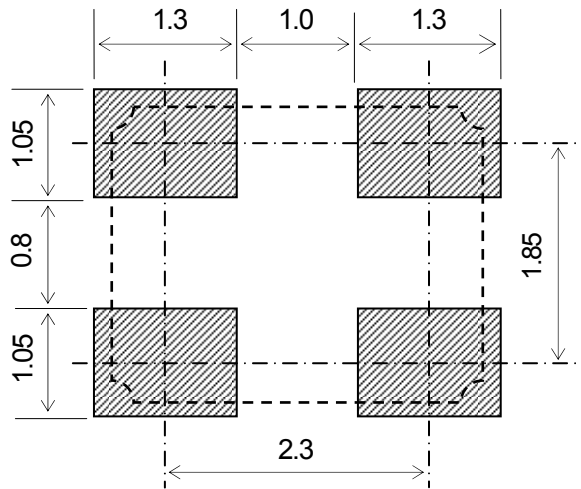
**6. RECOMMENDED LAND PATTERN (not to scale)**

UNIT : mm

### 7.TAPING & REEL

#### 7-1.Dimensions

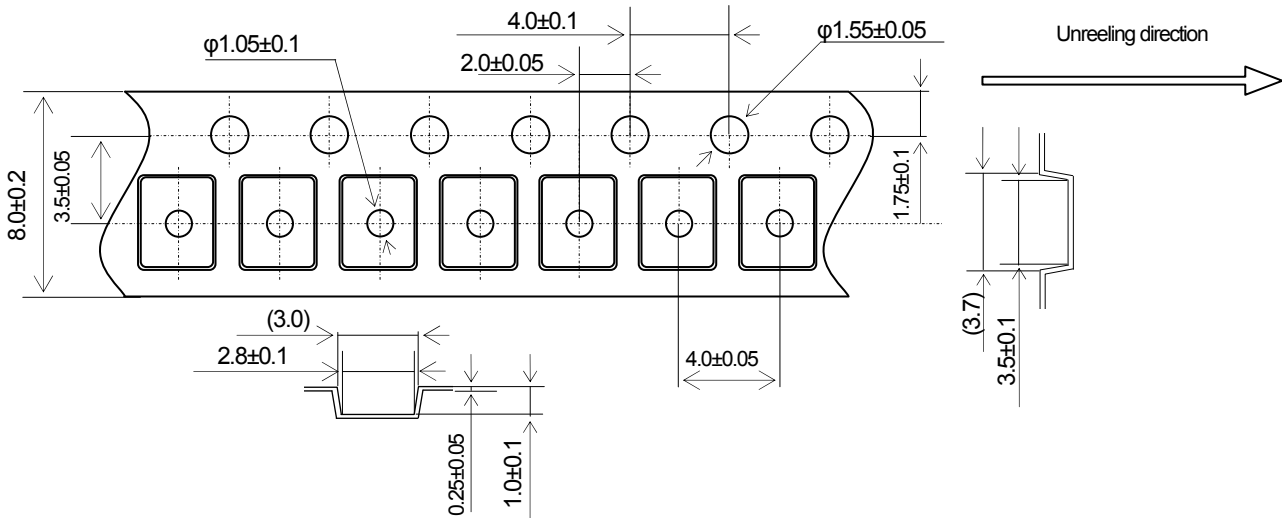

#### 7-2.Leader and trailer tape

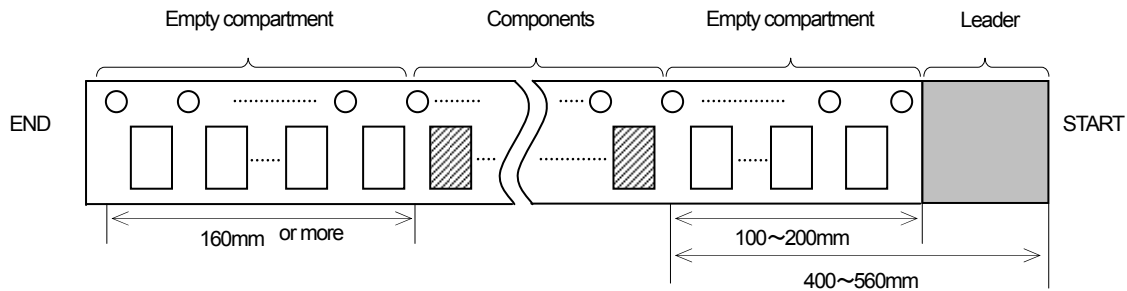

#### 7-3.Direction (The direction shall be seen from the top cover tape side)

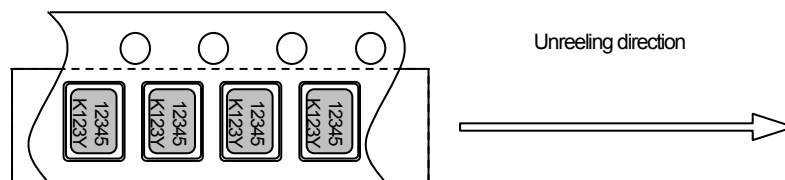

#### 7-4.Specification

1. Material of the carrier tape shall be polystyrene or A-PET (ESD).
2. Material of the seal tape shall be polyester(ESD).
3. The seal tape shall not cover the sprocket holes. And not protrude from the carrier tape.
4. Tensile strength of the tape : 10N or more.
5. The R of the corner without designation is 0.2RMAX.
6. Disalignment between centers of the cavity and sprocket hole shall be 0.05mm or less.
7. Cumulative pitch tolerance of "P<sub>0</sub>" shall be  $\pm 0.2$ mm at 10 pitches.
8. Suppose that it unifies as shown in the above-mentioned figure to the directivity of printing in an embossing tape.
9. Peeling force of the seal tape: 0.1 to 1.0N.
10. The component can fall headlong naturally from taping in the environment, such dry conditions, when this components were transferred to, cover was removed and the component was moved upside down.



**7-5.Reel Specification**

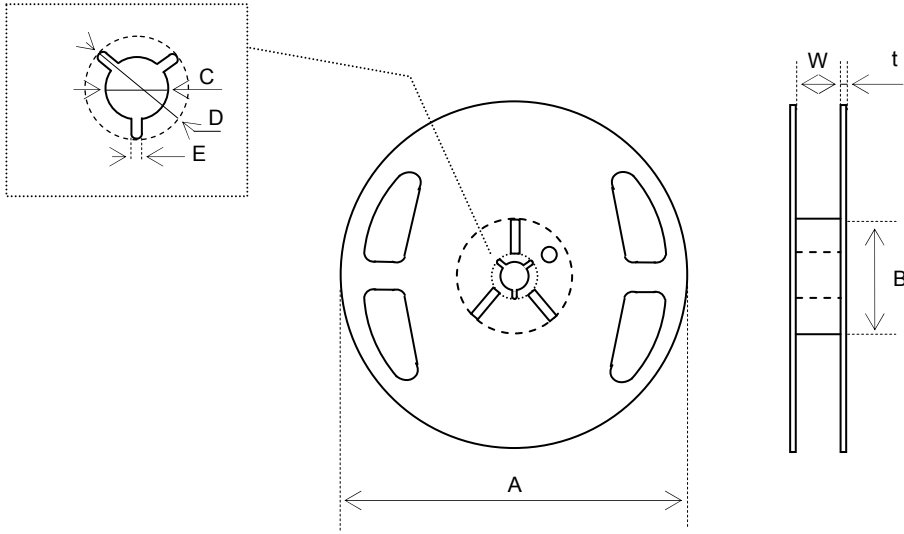

In the case of  $\Phi 180$  Reel (3,000 pcs max, every 1,000 pcs)

Symbol	A	B	C	D
Dimension	$\phi 180 +0/-3$	$\phi 60 +1/-0$	$\phi 13\pm 0.2$	$\phi 21\pm 0.8$
Symbol	E	W	t	
Dimension	$2.0\pm 0.5$	$9\pm 1$	$2.0\pm 0.5$	

(Unit : mm)

In the case of  $\Phi 330$  Reel (10,000 pcs max, every 1,000 pcs)

Symbol	A	B	C	D
Dimension	$\phi 330\pm 2.0$	$\phi 100\pm 1.0$	$\phi 13\pm 0.2$	$\phi 21\pm 0.8$
Symbol	E	W	t	
Dimension	$2.0\pm 0.5$	$9.5\pm 0.5$	$2.2\pm 0.1$	

(Unit : mm)

## 8. Environmental requirements

After following test, frequency shall not change more than  $\pm 10 \times 10^{-6}$

And CI,  $\pm 20\%$  or  $5\Omega$  of large value.

- |     |                         |  |
|-----|-------------------------|--|
| 8.1 | Resistance to Shock     | <p>Test condition</p> <p>Natural dropped from height 100cm onto hard wood board in 3 times</p>   |
| 8.2 | Resistance to Vibration | <p>Test condition</p> <p>frequency : 10 - 55 - 10 Hz</p> <p>Amplitude : 1.5mm</p> <p>Cycle time : 15 minutes</p> <p>Direction : X,Y,Z (3direction),2 h each.</p>   |
| 8.3 | Resistance to Heat      | <p>Test condition</p> <p>The quartz crystal unit shall be stored at a temperature of <math>+85 \pm 2^\circ\text{C}</math> for 500 h.</p> <p>Then it shall be subjected to standard atmospheric conditions for 1 h ,after which measurement shall be made.</p>  |
| 8.4 | Resistance to Cold      | <p>Test condition</p> <p>The quartz crystal unit shall be stored at a temperature of <math>-40 \pm 2^\circ\text{C}</math> for 500 h.</p> <p>Then it shall be subjected to standard atmospheric conditions for 1 h ,after which measurement shall be made.</p>  |
| 8.5 | Thermal Shock           | <p>Test condition</p> <p>The quartz crystal unit shall be subjected to 500 successive change of temperature cycles , each as shown in table below, Then it shall be subjected to standard atmospheric conditions for 1h, after which measurements shall be made.</p> <p>Cycle : <math>-40 \pm 2^\circ\text{C}</math> (30min.) to <math>+25 \pm 2^\circ\text{C}</math> (5min.)<br/>to <math>+85 \pm 2^\circ\text{C}</math> (30min.) to <math>+25 \pm 2^\circ\text{C}</math> (5min.)</p> |



8.6 Resistance to Moisture

Test condition

The quartz crystal unit shall be stored at a temperature of  $+60 \pm 2^\circ\text{C}$  with relative humidity of 90% to 95% for 240 h. Then it shall be subjected to standard atmospheric conditions for 1h, after which measurements shall be made

8.7 Soldering condition

1.) Material of solder

Kind ... lead free solder paste

Melting point ...  $+220 \pm 5^\circ\text{C}$

2.) Reflow temp.profile

	Temp [ $^\circ\text{C}$ ]	Time[sec]
Preheating	+150 to +180	150 (typ.)
Peak	$+260 \pm 5$	10 (max.)
Total	—	300 (max.)

Frequency shift :  $\pm 2\text{ppm}$

3.) Hand Soldering + $350^\circ\text{C}$  3 sec MAX

4.) Reflow Times 2 times

Reflow temp.profile

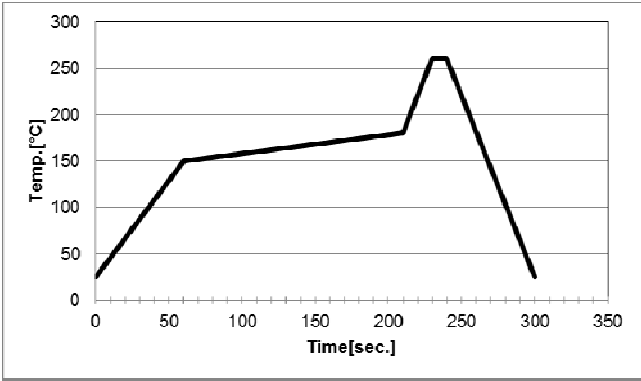

8.8 Intensity for bending in circuit board

Solder this product in center of the circuit board of  $40\text{mm} \times 100\text{mm}$ , and add the deflection of 3mm as the bottom figure.

Test board :  $t = 1.6\text{mm}$

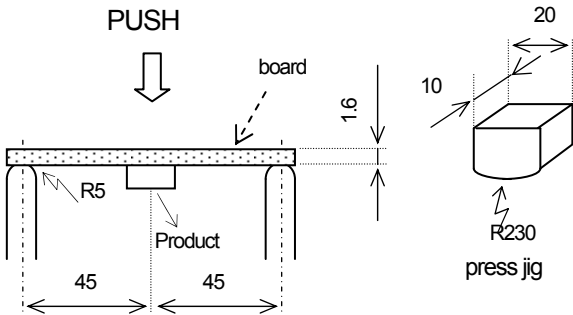

UNIT : mm

## 9. Cautions for use

### (1) Soldering in mounting

In case of Solder paste and conductive glue contact product lid or product side face exception for product terminal it's possible to influence product characteristics.

Please be careful above contents.

### (2) Automatic mounting machine use

Please use after affirmation that select the mounting machine model with a shock small if possible in the case of use of an automatic mounting machine, and it does not have breakage. There is a risk of a quartz crystal unit breakage occurring and not functioning normally by too much shock etc.

### (3) Conformity of a circuit

In case of use of an oscillation circuit, please insert in a crystal oscillating child in series resistance 5 times as many as the standard value of equivalent in-series resistance, and confirm oscillating. Please remove resistance which inserted after the notes above-mentioned examination in the quartz crystal unit in series, and use it.

## 10. Storage conditions

Storage at prolonged high temperature or low temperature and the storage by high humidity cause degradation of frequency accuracy, and degradation of soldering nature. Storage is performed at the temperature of +18 to +30°C, and the humidity of 20 to 70 % in the state of packing, and a term is 6 months.

## 11. Manufacturing location

Kyocera Crystal Device Corporation

Kyocera Crystal Device Corporation Shiga Yohkaichi Plant

Kyocera Crystal Device (Thailand) Co., Ltd

Kyocera Crystal Device Philippines, Inc.

## 12. Quality Assurance

Kyocera Crystal Device Quality Assurance Division

## 13. Quality guarantee

When the failure by the responsibility of our company occurs clearly after delivery within 1 year, a substitute article etc. is appropriated gratuitously and this is guaranteed. However, when passing 1 year after delivery, there is a case where I am allowed to consider as onerous repair after both consultation.

## 14. Others

When any questions and opinions are in the written matter of these delivery specifications, I will ask connection of you from the company issue day within 45 days. In a connection no case, a written matter is consented to it and employed within a term.

单击下面可查看定价，库存，交付和生命周期等信息

[>>Kyocera\(京瓷\)](#)