

High Performance Current Transducer IT 1000-S/SP1 ULTRASTAB

For the electronic measurement of currents: DC, AC, pulsed..., with galvanic separation between the primary circuit and the secondary circuit.

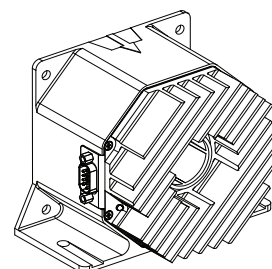

$$I_{PM} = 0 \dots 1000 \text{ A}$$



Features

- Closed loop (compensated) current transducer using an extremely accurate zero flux detector
- Electrostatic shield between primary and secondary circuit.

Special features

- 9-pin D-SUB male secondary connector
- Output indicates the transducer state
- LED indicator confirms normal operation.

Advantages

- Excellent accuracy
- Very good linearity
- Low temperature drift
- Wide frequency bandwidth
- High immunity to external electrostatic and magnetic fields interference
- No insertion losses
- High resolution
- Low noise on output signal
- Low noise feedback to main conductor.

Applications

- Feedback element in high performance gradient amplifiers for MRI
- Feedback element in precision current regulated devices (power supplies ...)
- Calibration units
- Precise and high stability inverters
- Energy measurement
- Medical equipment.

Application Domains

- Industrial and Medical.

Electrical data

$I_{PND C}$	Primary nominal direct current (continuous)	1000	A
$I_{P N}$	Primary nominal RMS current	707	A
$I_{P M}$	Primary current, measuring range	0 ... ± 1000	A
$\hat{I}_{P \max}$	Primary withstand peak current 100 ms ¹⁾	± 4000	A
R_M	Measuring resistance	$R_{M \min}$ $R_{M \max}$	
	Over operating current, temperature and supply voltage range	0 3	Ω
I_S	Secondary current	0 ... ± 1000	mA
$I_{S N}$	Secondary nominal RMS current	707	mA
N_P/N_S	Turns ratio	1 : 1000	
U_C	Supply voltage ($\pm 5\%$)	± 15	V
I_C	Current consumption @ $U_C = \pm 15 \text{ V}$, @ $I_P = 0 \text{ A}$	$\leq 80 + I_S$	mA

Accuracy - Dynamic performance data

ϵ_L	Linearity error ²⁾	≤ 3	ppm
I_{OE}	Electrical offset current + self magnetization + effect of earth magnetic field @ $T_A = 25 \text{ }^\circ\text{C}$ ²⁾	≤ 50	ppm
ΔI_{OE}	Offset stability (no load) ²⁾	≤ 1	ppm/month
TCI_{OE}	Temperature coefficient of I_{OE} (10 $^\circ\text{C}$... 50 $^\circ\text{C}$) ²⁾	≤ 0.5	ppm/K
	Offset vs. power supply stability @ $T_A = 25 \text{ }^\circ\text{C}$ ²⁾		
	@ $U_C = +15 \text{ V}$ ($\pm 5\%$)	≤ 3	ppm/% of $U_C = +15 \text{ V}$

General data

T_A	Ambient operating temperature	+10 ... +50	$^\circ\text{C}$
$T_{A \text{ st}}$	Ambient storage temperature	-20 ... +85	$^\circ\text{C}$
RH	Relative humidity (non condensing)	20 ... 80	%
R_S	Resistance of secondary winding @ $T_A = 25 \text{ }^\circ\text{C}$	6	Ω
m	Mass	1	kg

Notes: ¹⁾ Single pulse only, not AC.

The transducer may require a few seconds to return to normal operation when autoreset system is running.

²⁾ All ppm figures refer to secondary measuring range 1000 mA.

Current Transducer IT 1000-S/SP1 ULTRASTAB

Insulation coordination

U_{Nm}	Rated insulation RMS voltage, reinforced insulation	300	V
	Rated insulation RMS voltage, basic insulation with IEC 61010-1 standard and following conditions - Over voltage category III - Pollution degree 2	600	V
U_d	RMS voltage for AC insulation test, 50/60 Hz, 1 min	3.1 ¹⁾	kV
		200 ²⁾	V DC
U_{Ni}	Impulse withstand voltage 1.2/50 μ s	5.7	kV
U_{Nm}	Rated insulation RMS voltage, reinforced insulation	300	V
	Rated insulation RMS voltage, basic insulation with EN 50178 standard and following conditions - Over voltage category III - Pollution degree 2	600	V
d_{Cp}	Creepage distance	9	mm
d_{Ci}	Clearance	6	mm
CTI	Comparative tracking index (group I)	600	

If isolated cable is used for the primary circuit, the voltage category could be improved with the following table (for single isolation) (IEC 61010-1 standard):

Cable isolated (primary)	Category
HAR03	450 V CAT III
HAR05	550 V CAT III
HAR07	650 V CAT III

Notes: ¹⁾ Between primary and secondary + shield
²⁾ Between secondary and shield.

Safety

This transducer must be used in limited-energy secondary circuits according to IEC 61010-1.



This transducer must be used in electric/electronic equipment with respect to applicable standards and safety requirements in accordance with the manufacturer's operating instructions.



Caution, risk of electrical shock

When operating the transducer, certain parts of the module can carry hazardous voltage (e.g. primary busbar, power supply).

Ignoring this warning can lead to injury and/or cause serious damage.

This transducer is a build-in device, whose conducting parts must be inaccessible after installation.

A protective housing or additional shield could be used.

Main supply must be able to be disconnected.

Current Transducer IT 1000-S/SP1 ULTRASTAB

Output noise @ 25 °C

Random Noise ppm (RMS):

0 - 10 Hz	0 - 10 kHz	0 - 50 kHz
< 0.05	< 3	< 6

Re-injected noise measured on primary cable (DC - 50 kHz) < 5 μV_{RMS}

Dynamic performance data

BW Frequency bandwidth for small signal 0.5 %, of $I_{PN DC}$ (± 3 dB) DC ... > 500 kHz
 t_{D90} Delay time to 90 % ¹⁾ of the final output value for I_{PN} step < 1 μs

Note: ¹⁾ For a $di/dt = 100 A/\mu s$.

Current Transducer IT 1000-S/SP1 ULTRASTAB

Overcurrent protection - Electrical specification - Status

As soon as electrical saturation appears, the transducer switches from normal operation to Overcurrent mode.

This electrical saturation appears in any case beyond 1.1 time the current range.

The primary current corresponding to this trip level is related to the temperature inside the transducer.

Under these conditions:

- the contact (operation status) between pin 3 to 8 (of D-SUB-9 connector) switches off, this contact becomes open.
- the green LED (located on the cover plate of the transducer and related to operation status) switches off.

Fault level (off state)	$I_p > 110 \% \text{ of } I_{PNDC}$
Max voltage pin 3 to pin 8, off-State	45 V
Max current pin 3 to pin 8, on-State	30 mA
On state resistance pin 3 to pin 8	50 mΩ (typ)

To maintain safe start-up R_M must not exceed 3 Ω during fault condition.

The Overcurrent mode remains until the primary current decreases to a value lower than the recovery current.

Max secondary current versus measuring resistor

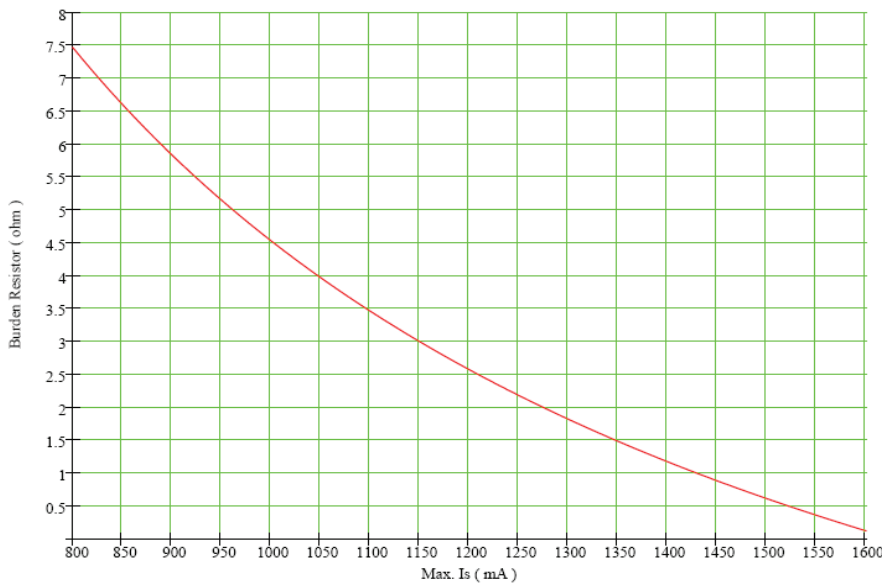

To maintain safe start-up R_M must not exceed 3 Ω during fault condition.

Miscellaneous

Bus bar free zone (length: 110 mm) (from center) $r \geq 110$ mm

Dimensions IT 1000-S/SP1 ULTRASTAB (in mm)

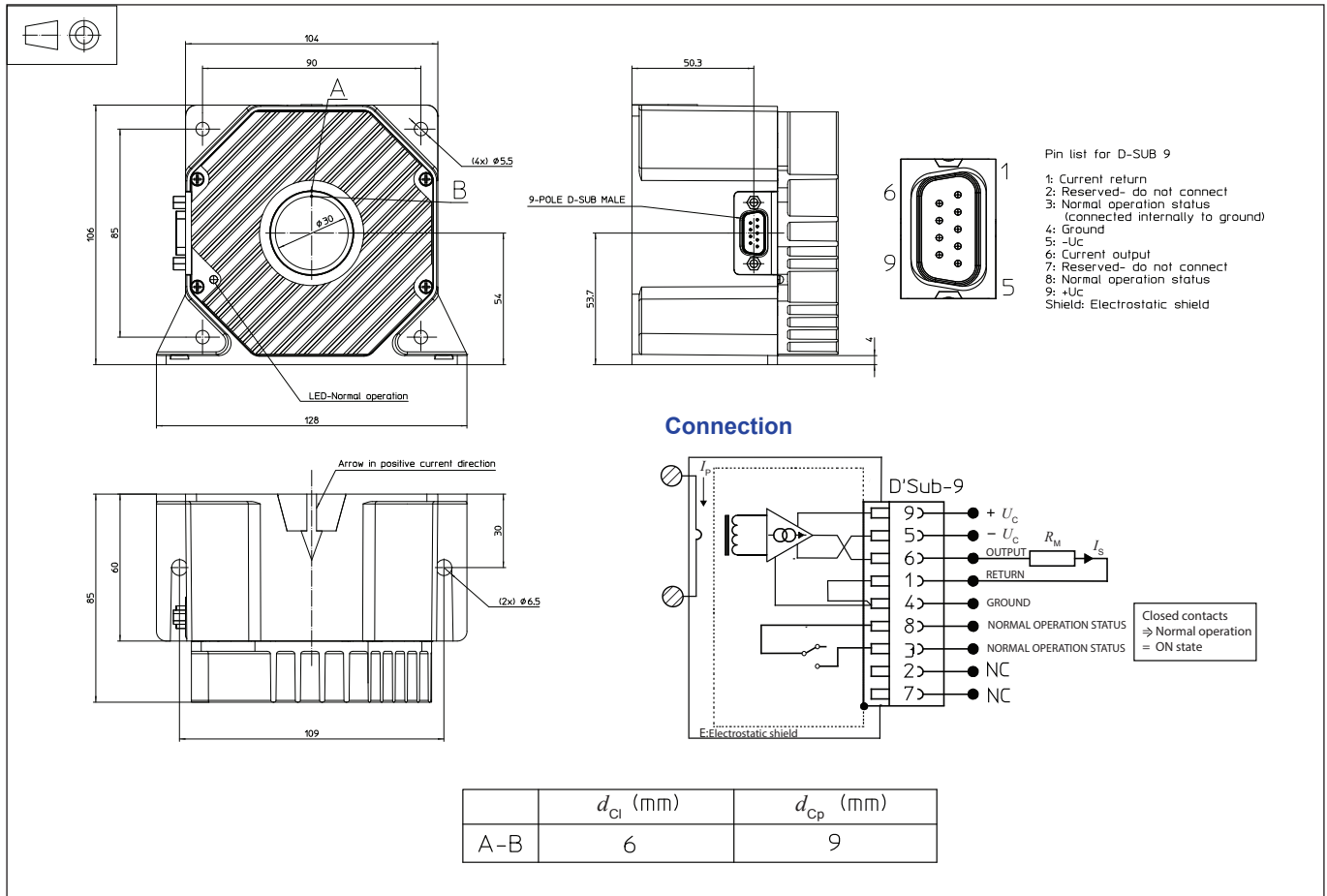

Mechanical characteristics

- General tolerance ± 0.5 mm
- Transducer fastening
 - Straight mounting 2 holes $\varnothing 6.5$ mm
2 \times M6 steel screws
 - Recommended fastening torque 4.4 N·m
 - Flat mounting 4 holes $\varnothing 5.5$ mm
4 \times M5 steel screws
 - Recommended fastening torque 3.7 N·m
- Connection of secondary connector on D-SUB-9, UNC 4-40
- All mounting recommendations are given for a standard mounting. Screws with flat and spring washers.
- Primary through-hole $\varnothing \leq 30$ mm

Connection

- Normal operation status (Pins 3 to 8)
Normal operation means:
 - ± 15 V present
 - zero detector is working
 - compensation current $\leq 110\%$ of $I_{PND C}$

The contacts of the related relay are closed under normal operation.

Remarks

- I_s is positive when I_p flows in the direction of the arrow.
- We recommend that a shielded output cable and plug are used to ensure the maximum immunity against electrostatic fields.
- Pin 4 should be connected to cable and connector shield to maintain lowest output noise.
- Temperature of the primary conductor should not exceed 50°C .

单击下面可查看定价，库存，交付和生命周期等信息

[>>LEM\(莱姆\)](#)