

IST ULTRASTAB

Power Supply for IT/ITN/IN ULTRASTAB transducers

High performance 6-channel power supply for multi-channel laboratory measurement applications.



Features

- Current output or ± 10 V voltage output ([see table on page 5](#) for available versions)
- Six individual channels with 9-pin D-sub female connector for IT/ITN/IN transducers
- Safety standard laboratory “banana” output jacks
- 19” rack mountable cabinet.

Special features

- Universal mains input (100 ... 240 V RMS, 50-60 Hz)
- 15-pin D-Sub male connector for access to status signals for all six channels
- LED indicators showing operational status of unit and of each individual channel (“Operational”, “Not operational”, “Not connected”).

Advantages

- Convenient solution when operating 1 to 6 IT/ITN/IN transducers in one setup
- Integrates in standard 19” rack system typically used in laboratory and industrial test setups
- The output current version allows measurement signal to travel long distances by using external burden resistor, i.e., current-to-voltage conversion is done by a precision resistor in attached measurement system (eg.: Power Analyser, etc.).

Applications

- Laboratory setup
- Industrial test bench
- Analogue current measurement frontend for multi-input power analyser, eg. for 3-phase measurements on AC motors, power inverters etc.

Standards

EMC:

- EN 61000-6-2: 2019
- EN 61000-6-3: 2007 + A1 (2011)
- EN 61326-1: 2013

Safety:

- IEC 61010-1: 2010/AMD1: 2016.

Application Domains

- Laboratory
- Industrial.

Safety

Read the information below before using this instrument.

The following general safety precautions must be observed during all phases of operation and service.

Failure to comply with these precautions or with specific warnings elsewhere in this manual violates safety standards for design, manufacture, and intended use of the instrument.

LEM International S.A. assumes no liability for the customer's failure to comply with these requirements.

Do not use this product in any manner not specified by the manufacturer.

The protective features of this product may be impaired if it is used in a manner not specified in the operation instructions.

CAUTIONS:

- Use the device with the cables provided with the shipment.
- In case of main supply cable replacement, make sure to use similar cable to guaranty safety; please refer to the user manual.
- If the device is used in a manner not specified by the manufacturer, the device protection may be impaired.
- Shall not be opened or modified
- Main supply must be able to be disconnected
- This power supply must be mounted in a suitable end-enclosure
- This power supply is a built-in device, no maintenance required; cleaning by dry compressed air is authorized.
- Do not permit any blockage of the ventilation holes of the device.

WARNINGS:

- Do not use the device if it appears damaged or defective.
- REMOVE POWER and do not use the device until safe operation is verified by service-trained personnel.
- If necessary, return the device to LEM for service and repair to ensure that the safety features are maintained.
- Do not operate the device around flammable gases or fumes, vapor, or wet environments.
- Observe all markings on the device before connecting any wiring to the device.
- Disconnect main power cable before connecting the output terminals.
- Do not install substitute parts or perform any unauthorized modification to the device.
- Return the device to LEM for service and repair to ensure that the safety features are maintained.
- Do not operate the device with the cover removed or loosened.

This power supply is a Safety Class I instrument, which means that it has a protective earth terminal.

This terminal must be connected to earth ground through a power source with a 3-wire ground receptacle.

Before installation or operation, check the power supply and review this manual for safety markings and instructions.

Mains INPUT

Parameter	Symbol	Unit	Value	Comment
Mains supply voltage	U_C	V RMS	100-240 V AC ($\pm 10\%$)	IEC-type inlet socket OVCII and PD2
Fuse rating		At/V	2.5 At/ 240 V AC	user-replaceable
Rated power supply frequency	f	Hz	50-60	
Power consumption	P_C	W	< 200 ¹⁾	with 240 V RMS

Note: ¹⁾ All channels driven at max 1 A secondary output current.

Transducer port

Parameter	Symbol	Unit	Value	Comment
Supply voltage	U_C	V DC	± 15	
Ripple		mV RMS	< 15	
Noise		mV RMS	< 15	
Load regulation		%	< 5	

Note: ¹⁾ In case of high overloads (> 15 kA), internal power supply can raise up to -19 V in case of overloads > +15 kA and +19 V in case of overloads > -15 kA.

So, a certain caution should be taken vs the associated sensors to protect them against these overloads conditions. In these special overloads conditions of use, the main supply enters in protection mode and falls down to 0 V.

Then this requires to switch off the main AC supply during 1 minute so that the IST to operate in normal mode again.

Environmental and mechanical characteristics

Parameter	Symbol	Unit	Min	Typ	Max	Comment
Ambient operating temperature	T_A	°C	10		40	
Ambient storage temperature	$T_{A\text{st}}$	°C	-20		85	
Maximum primary conductor temperature	$T_{B\text{max}}$	°C			100	
Relative humidity	RH	%	20		80	
Dimensions		mm				483 × 88 × 290 W × H × D
Environmental conditions						Indoor
Cooling conditions						Natural convection
Altitude		m			2000 ¹⁾	
Mass	m	kg		4.2		

Note: ¹⁾ Insulation coordination at 2000 m.

Electrical data - status port

Parameter	Symbol	Unit	Min	Typ	Max	Comment
Collector-emitter voltage, off-state	$U_{CE\ off}$	V	4		45	
Collector-emitter current, on-state	I_{CE}	mA	2		30	
Reverse collector-emitter voltage, off-state	$U_{CER\ off}$	V			5	
Collector-emitter voltage, on-state	$U_{CE\ on}$	V		0.2	1	¹⁾
				0.8	1	²⁾

Notes: ¹⁾ Conditions: see diagram A on [page 6](#)

²⁾ Conditions: see diagram B on [page 6](#).

Insulation characteristics

Insulation voltage between rack electronics and status port connections: 3 kV RMS.

The IST ULTRASTAB supports the products (transducers), which are shown in the table below:

Current range	Products
60 A	IT 60-S, IT 65-S
100 A	IN 100-S
200 A	IT 200-S, IT 205-S, IN 200-S
400 A	IT 400-S, IT 405-S, IN 400-S
500 A	IN 500-S
600 A	IT 605-S, ITN 600-S
700 A	IT 700-S
900 A	ITN 900-S
1000 A	IT 1000-S/SP1, ITN 1000-S, IN 1000-S
1200 A	IN 1200-S
2000 A	IN 2000-S ¹⁾

Note: ¹⁾ For IN 2000-S series and only in pure AC measurement, the IST ULTRASTAB can provide the power for 6 channels. For DC measurement or for AC and DC combined, the IST ULTRASTAB provides the power for 4 channels maximum.

Description	Order number	Secondary output current	Output current
IST 200-B ULTRASTAB	71.93.44.000.0	±200 mA	±10 V
IST 400-B ULTRASTAB	71.93.48.000.0	±400 mA	±10 V

Available versions with ±10 V output voltage

Transducer connector 1 to 6:

The pin OUT for the transducer connector 9-pin D-Sub female, located on the back panel of the IST ULTRASTAB, is shown in the table below:

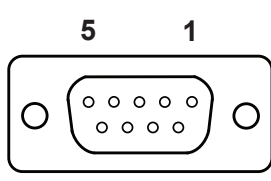
Pin 1: Output current return	 <p>9-pin D-Sub female UNC 4-40 screw lock</p>
Pin 2: N/C	
Pin 3: Ground	
Pin 4: Ground	
Pin 5: Negative supply -15 V	
Pin 6: Output current	
Pin 7: N/C	
Pin 8: Normal operation	
Pin 9: Positive supply +15 V	

“Banana” jacks output terminals 1 to 6:

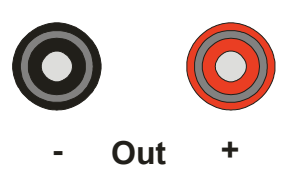
<p>Red: Current output or ±10 V voltage output depending on IST version. In current output case, this terminal is connected directly to pin 6 of the corresponding transducer port</p>	 <p>- Out +</p>
<p>Black: Current output return or ±10 V signal ground. In current output case, this terminal is connected directly to pin 1 of the corresponding transducer port</p>	

Two “Banana” jacks, located on the back panel of the IST ULTRASTAB, allow the connection of the secondary current outputs or the ±10 V voltage outputs to the measurement device.

Status/Interlock connector

All ITN/IN ULTRASTAB transducers attached to the IST ULTRASTAB generate a status signal, which provides information about the operation of the transducer. This signal is routed through a photocoupler in the IST ULTRASTAB and available in one 15-pin D-Sub male connector containing status signals for 6 channels.

Power Status: Pin 1 Collector & Pin 5 Emitter	<p>15-pin D-Sub male UNC 4-40 screw lock</p>
Channel 1: Pin 9 Collector & Pin 13 Emitter	
Channel 2: Pin 2 Collector & Pin 6 Emitter	
Channel 3: Pin 10 Collector & Pin 14 Emitter	
Channel 4: Pin 3 Collector & Pin 7 Emitter	
Channel 5: Pin 11 Collector & Pin 15 Emitter	
Channel 6: Pin 4 Collector & Pin 8 Emitter	

All signals on the status/interlock connector are optically isolated, photocouplers type, floating Collector and Emitter.

Status/Interlock port Wiring

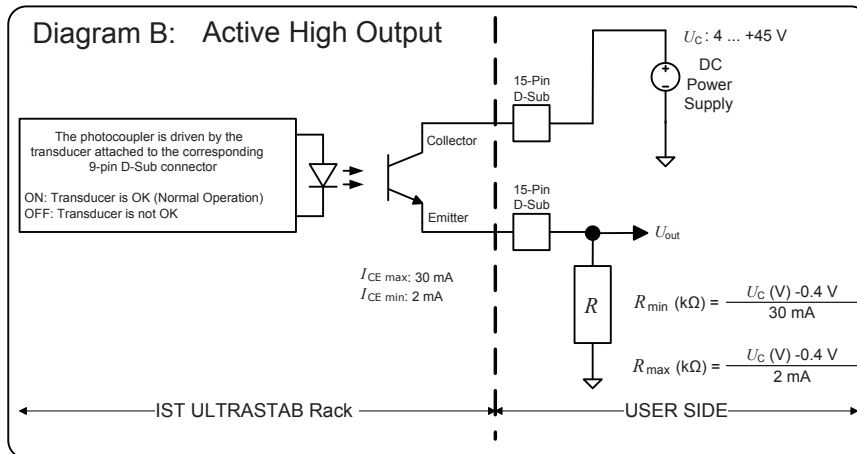
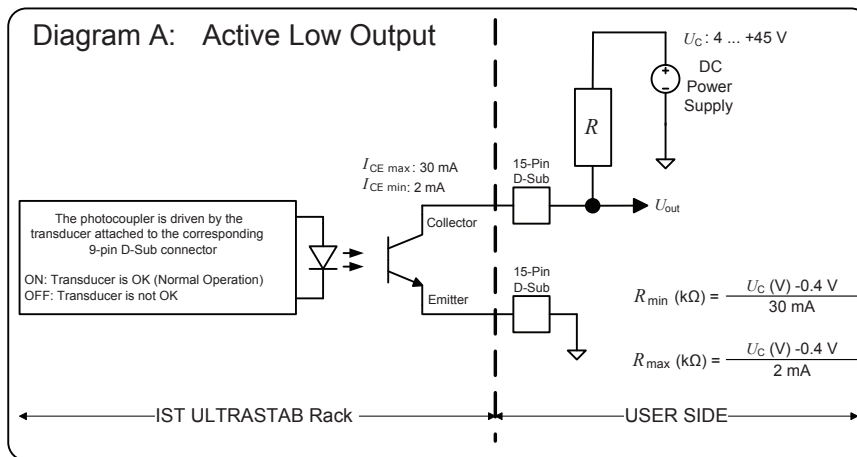

In the diagram A, the active low output signal U_{out} switches to GND when the corresponding transducer is OK (Normal operation and Green LED is lit). In the same manner, the transistor is switched off (No current from collector to emitter) to indicate that the corresponding transducer is not OK. Consequently, U_{out} switches to U_C and the corresponding Green LED is OFF, whereas the corresponding Red LED is lit.

In the diagram B, the active high output signal U_{out} switches to U_C when the corresponding transducer is OK (Normal operation and Green LED is lit). In the same manner, the transistor is switched off (No current from collector to emitter) to indicate that the corresponding transducer is not OK. Consequently, U_{out} switches to GND and the corresponding Green LED is OFF, whereas the corresponding Red LED is lit.

The power supply (TBTS power voltage) voltage U_C must be between 4 V and 45 V DC and the resistor value R must be chosen between a minimum value R_{min} and a maximum value R_{max} .

Some recommended standard values of R are given in the following table:

Power supply voltage U_c	R_{min} (k Ω)	R_{max} (k Ω)	R standard values $\pm 5\%$
5 V	0.153	2.3	180 Ω , 1 k Ω or 2.2 k Ω
12 V	0.386	5.8	470 Ω , 2.2 k Ω or 4.7 k Ω
24 V	0.786	11.8	1 k Ω , 2.2 k Ω or 10 k Ω

FRONT PANEL



INDICATOR PANEL

The illuminated indicator panel has seven fields that are lit in the following modes:

POWER:

- **Green light** - mains power is applied.
- **No light** - Unit is in off-state.

CHANNEL 1 to 6:

- **Green light** - Indicated transducer is attached and normal operation signal is OK. Transducer is operational.
- **Red light** - Indicated transducer is attached and normal operation signal is not OK.
- **No light** - No transducer is connected.



BACK PANEL

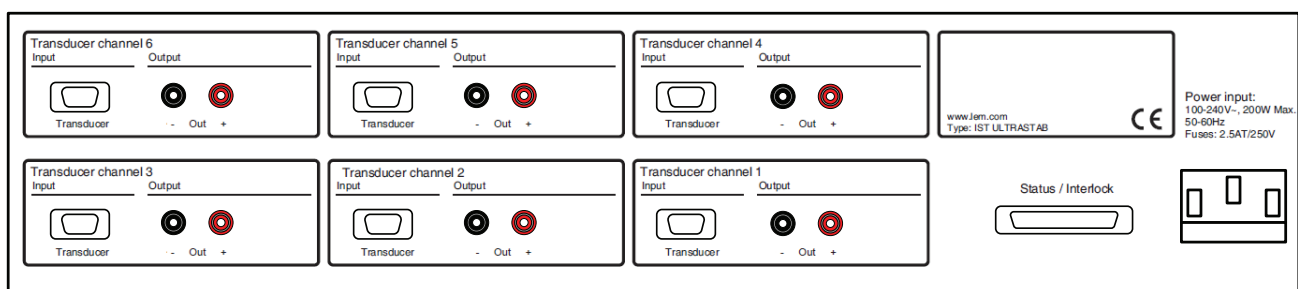

CONNECTING THE TRANSDUCERS

The IST ULTRASTAB rack provides 6 connectors (9-pin D-Sub) on the back panel for connecting up to 6 IT/ITN/IN individual transducers.

Each 9-pin D-Sub connector is used to connect the supply voltage to the DC power input of the transducer. It also routes the secondary current lines and the status signal from the transducer to the IST ULTRASTAB unit.

Connect the transducers at the 9-pin D-Sub connectors on the IST ULTRASTAB back panel via the shielded connection cables which have to be ordered separately.

The shielded connection cable for operating a transducer is shown in the following figure:

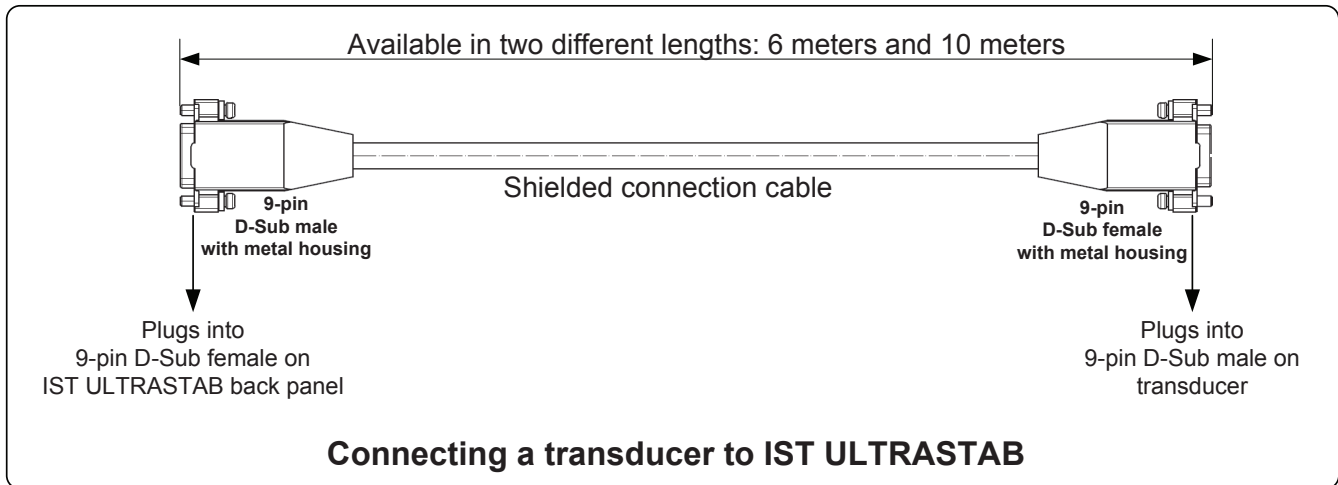

The following 2 shielded connection cables are available:

Description	Order number
Shielded connection cable length = 6 meters	71.12.08.000.0
Shielded connection cable length = 10 meters	71.12.13.000.0

It is recommended to use the connection cables indicated above. It is also possible to configure your own cable, bearing the following description in mind.

The connection cable wiring is shown below:

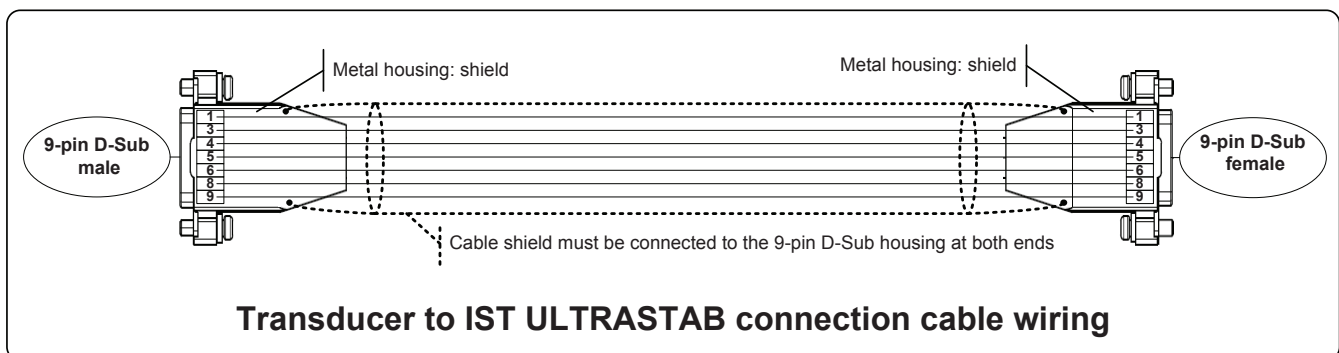

To prevent any malfunction that may occur due to the cable/wire voltage drop (i.e., its length and the wire resistance inside the cable) between the IST ULTRASTAB rack and the transducer, a cable with at least 7 wires, each having a cross section AWG 22, AWG 23 or $\geq 0.25 \text{ mm}^2$, must be used.

In addition, it is recommended to use shielded cables in order to limit the effects of noise due to electromagnetic interference (EMI).

单击下面可查看定价，库存，交付和生命周期等信息

[>>LEM\(莱姆\)](#)